

Energetic, Environmental and Economic Modeling of a Solar-Assisted Residential Micro-Trigeneration System in a Mediterranean Climate

Simon P. Borg, PhD

Member ASHRAE

Nicolas J. Kelly, PhD

Vincent Buhagiar, PhD

ABSTRACT

Reducing energy consumption in buildings has become a priority for most countries. However, designing energy-efficient buildings is not a straightforward task - the increasing demand for high comfort standards, provided by conventional 'energy-hungry' cooling and heating devices conflicts with the need for demand reduction. Trigeneration, the simultaneous production of electricity, cooling and heating is often viewed as a means of improving energy-efficiency in large and medium sized buildings whilst still delivering thermal comfort. For hot climates, the benefit of utilising the waste heat emitted from an engine unit to power a thermally driven cooling device provides scope to utilise an otherwise wasted energy stream. However, in smaller sized residential buildings, the relatively low and intermittent energy demand coupled with high capital costs, has stifled the uptake of the technology - although the potential for substantial energy savings exists. Moreover, it is very common for home owners in hot climates to opt for other energy-saving devices such as solar water heaters (SWH), which would tend to reduce further the possible demand for space and water heating, possibly making the simultaneous use of both micro-trigeneration and SWH unfeasible. This paper compares the performance of a residential micro-trigeneration system to a hybrid micro-trigeneration/SWH system. The performance of both systems was simulated using a whole building simulation tool run at a high time resolution. The results obtained were then used to quantify the energetic and environmental performance of both systems; and also to assess their financial viability against the effect of varying fuel prices, electricity tariffs and a varying Feed-in Tariff (FIT). Results show that whereas the solar aided micro-trigeneration system obtains an overall higher (though marginal) energetic and environmental performance, the financial performance for the same fiscal parameters (fuel prices and electricity tariffs) deteriorates. Moreover FIT, plays an important role in the financial feasibility of the system.

INTRODUCTION – THE ROLE OF TRIGENERATION

In the EU (Enerdata, 2012) and the US (DOE, 2013), the built environment accounts for about 40% of the total energy consumption and it is generally agreed that energy savings obtained from this sector could be very important in improving final energy efficiency, reducing the overall energy demand and curbing green house gas emissions.

Traditionally, in buildings, the provision of space and domestic water heating, space cooling and electricity has always been through separate generation, which results in primary energy wastage as a result of inefficient energy conversion processes in central power stations and the need for electricity distribution over long distances. One technology which could eliminate these issues is trigeneration, that is, the simultaneous production of heating, cooling and power in a

Simon P. Borg and **Vincent Buhagiar** are respectively Lecturer and Professor in the Department of Environmental Design at the Faculty for the Built Environment of the University of Malta, Malta (EU). **Nicolas J. Kelly** is a Senior Lecturer within the Energy Systems Research Unit at the University of Strathclyde, Glasgow, UK.

cascading, energy recovery process. Trigeneration is similar to the more familiar concept of cogeneration, whereby the waste heat produced from an energy conversion process producing motive or electrical power is recovered to supply space and water heating inside a building. Trigeneration works on a similar principle with the only difference being that a waste-heat-driven thermally activated chiller, such as an absorption chiller, is added to the system to produce chilled water which can then be used to provide space cooling. Compared to cogeneration, trigeneration has the added benefit that in hot climates an otherwise underutilized resource, that is, the waste heat produced from the energy conversion process, can be used during periods of low heat demand. This increases the operational factor of the system rendering it more attractive.

Like most energy-efficient technologies, the capital cost for such trigeneration projects is always an issue and whereas profitable projects have been made for the industrial (Biezma and San Cristóbal, 2006) and commercial (Polonara *et al.*, 2009) sectors, micro-scale trigeneration projects (comprising systems smaller than 15kW_e) for individual or small multi-household building complexes, are still in the research and demonstration phase.

BACKGROUND INTO THE RESEARCH

Research on the use of micro-trigeneration in residential buildings has been ongoing for quite some time. A number of such studies have focused on laboratory setups (Lin *et al.*, 2007; Khatri *et al.*, 2010), whilst others (Fragiacomo *et al.*, 2007; Piacentino and Cardona, 2008) have made use of optimization processes to analyze a number of design aspects (*e.g.* size and type of trigeneration unit, control philosophy, *etc.*). However, questions such as how will a micro-trigeneration system behave under varying operating conditions (such as the variable thermal and electrical demand of a residential building) remain difficult to answer boundary conditions.

A very recent study on “*High resolution analysis of micro-trigeneration in an energy-efficient residential building situated in a Mediterranean climate*” (Borg and Kelly, 2013) addressed trigeneration performance issues in domestic buildings. The performance of a micro-trigeneration system subject to a number of varying scenarios and operational factors (outlined below) were analyzed. In this research, a whole building simulation package, ESP-r (ESRU, 2005), was utilized to run high resolution simulations of a micro-trigeneration system supplying heating, cooling and power to a small residential complex made up of 3 households in the Mediterranean island of Malta. A number of scenarios were modeled, representing different operational factors, including improved building envelope, building size, improved appliance electrical efficiency and different plant configurations, such as the addition of a chilled water storage tank. Based on the results obtained, each parameter or operational factor could be individually assessed to determine its effect on performance. Additionally, the study through a sensitivity analysis, also investigated the effect of varying economic parameters such as fuel prices and electricity tariffs. The performance metrics used to measure the system’s performance included the primary energy saved and consequent reduction in emissions, the system efficiency, system ‘On’/‘Off’ cycling, electricity generated, as well as economic metrics such as the system’s present worth and its payback period. It was shown that compared to conventional separate generation of energy, micro-trigeneration has the potential to deliver primary energy savings in the region of between 40% and 50%, resulting in similar reductions in greenhouse gas emissions. In terms of the specific operational factors modeled, improving the building envelope resulted in a lower system operating factor which translates into lower primary energy and emission savings. Conversely, being thermally driven, the micro-trigeneration system responded to changes in thermal demand only such that, reducing the overall electrical demand through improved appliances’ electrical efficiency led to an increase in primary energy savings and emissions savings. Adding a chilled water tank reduced the cycling ‘On’/‘Off’ of the trigeneration system but added parasitic losses which decreased the energetic and environmental performance. In terms of economic performance, generally it was observed that for all scenarios, increasing electricity tariffs made the system become more profitable, whilst increasing the fuel prices rendered the micro-trigeneration system less profitable.

The research presented in the paper is an extension to the work done in this former study, using the whole building software package ESP-r to look into an additional variable - the effect of adding a solar water heater (*SWH*) working in

parallel with the system. Also, the study introduces a new sensitivity parameter, the effect of a variable Feed-in Tariff (FIT) on the economic feasibility of the system.

MODELLING

Building Modeled – Geometrical and Building Envelope Characteristics, Electrical and Thermal Demands

Building Characteristics. The building model used in the simulations was modeled as a six storey building with a total floor space for each floor of 120m² [1,291.7ft²]; an average sized floor space for residential apartments in Malta (Abela *et al.*, 2011). The building envelope was modeled using U-Values lower than the maximum recommended by the *Technical Guidance - Conservation of Fuel, Energy and Natural Resources* (Building Regulations Office, 2006), which sets the minimum thermal performance for different building elements used in new buildings in Malta. Table 1 shows the U-Values for the different building elements used, and how they compare with the requirements of the *Technical Guidance*.

Table 1. Building Elements U-Values

Building Element	Description	Recommended U-value		U-Value Used	
		W/m ² K	Btu/b·ft ² ·°F	W/m ² K	Btu/b·ft ² ·°F
Windows	(Air-Gap) Double glazed	5.80	1.02	2.27	0.40
Roof	Incl. 180mm roof insulation	0.59	0.10	0.59	0.10
Exposed Walls	Incl. 50 mm insulation in-between walls	1.57	0.28	0.43	0.08
Non-Exposed Walls		N/A	N/A	1.16	0.20
Internal Walls		N/A	N/A	1.91	0.34

More details on the building model are given in Borg and Kelly (2013).

Electrical and Thermal Demands. Inside the building, six households were electrically and thermally modeled: 2x2 person households, 2x3 person household and 2x4 person households. The electrical demand for each household was modeled using an approach elaborated in Borg and Kelly (2011). In this research, hourly data from a monitoring program carried out in a number of European households (REMODECE Partners, 2008), was transformed using a three step approach into seasonal 1-minute electrical profiles representative of future energy-efficient electrical demand. These future energy-efficient electrical demand profiles are based on a number of assumptions (DEFRA, 2008) related to how certain household electrical appliances will become more energy-efficient in the future. Figure 1 shows the total electrical demand for the whole building (six households) for winter and summer. The corresponding thermal gain profiles were developed by relating occupancy and electrical demand to standard internal heat gain values (ASHRAE, 2009). The domestic hot water demand was generated using the hot water prediction tool designed by Jordan and Vajen (2005).

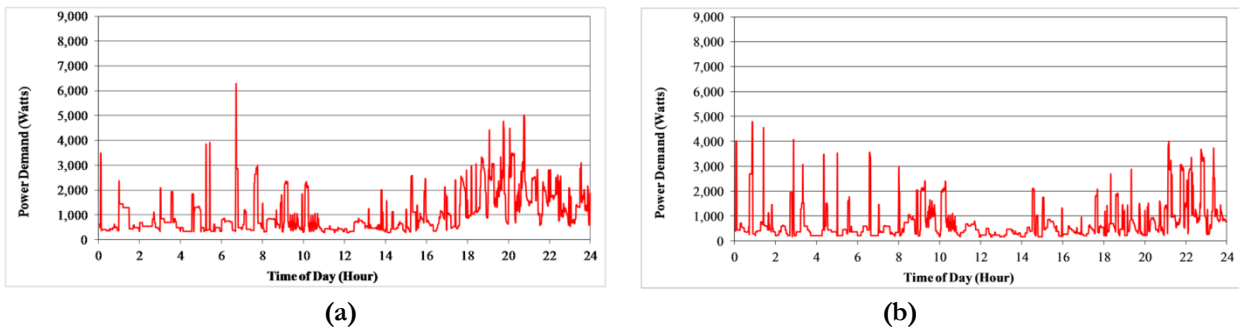

Figure 1 (a) Daily electrical profile – Winter (February) (b) Daily electrical profile – Summer (August)

Plant Configurations Modeled

Plant configuration without *SWH*. Figure 2 shows the plant configuration modeled having no *SWH*. It comprises a Liquefied Petroleum Gas (LPG) driven cogenerator (natural gas is not available in Malta), modeled to represent a CHP unit having an electrical and thermal output equal to 5.5kW_e and 12.5kW_t [$42,650\text{Btu/h}$], and a 10kW_t [$34,120\text{Btu/h}$] absorption chiller. The cogenerator unit is thermally controlled such that it keeps the hot water temperature inside the hot water storage tank within a specific temperature range of between 65°C (149°F) and 75°C (167°F), whilst an auxiliary heater provides for any short fall in the amount of heat required. Hot water stored in the hot water tank can either be supplied directly to the hot water coils providing space heating or else to the absorption cooler, thus providing chilled water for space cooling.

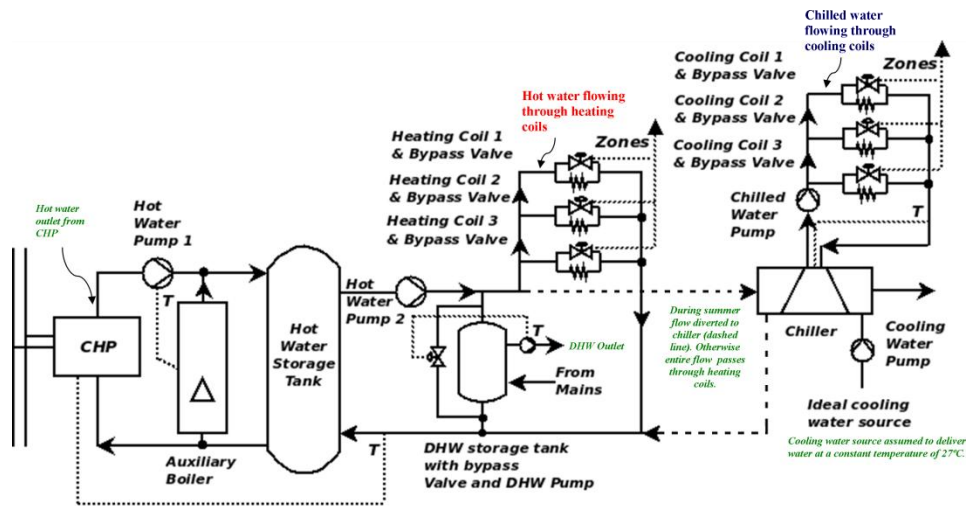

Figure 2 Plant configuration without *SWH*

Plant configuration with *SWH*. The plant system configuration with the additional *SWH* is shown in Figure 3. The system is identical to the one explained in the previous section, with the only difference being the additional *SWH*. The *SWH* installed just prior the return to the main tank is a flat plate *SWH* having a surface area of 10m^2 [107.6ft^2]. The *SWH* was modeled facing south, and a tilt of 45° for maximum annual energy collection (Borg *et al.*, 2005).

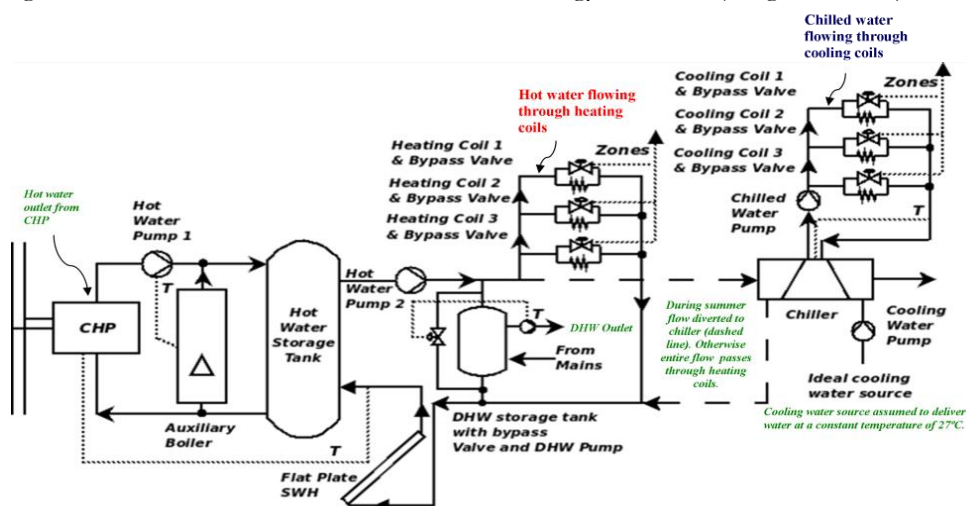

Figure 3 Plant configuration with additional *SWH*

The size of the flat plate SWH was selected based on obtaining an F-Ratio of around 0.6. The F-Ratio is a ratio detailing the share of useful solar energy absorbed compared to the annual hot water energy demand. For flat plate SWH , 0.6 is a value which for a Mediterranean climate such as that in Malta corresponds to an average hot water capacity of 50-60l/m² of flat plate panel [1.2-1.5 US gallons/ft²] at 60°C [140°F] output temperature.

COMPARING THE TWO PLANT CONFIGURATIONS

The two plant configurations were compared based on an energetic, environmental and economic performance metrics classification.

Energetic Performance

The energetic performance of the two plant configurations was quantified on the basis of each plant's primary energy consumption (PE_{PLT}) and primary energy saving (PES), compared to the equivalent separate generation (PE_{SEP}) of electricity and heat required to satisfy the combined thermal (Q_t) and electrical (Q_e) demand of the building as shown in equations (1), (2) and (3). The term η_e , represents the separate (grid-sourced) electrical primary energy efficiency for Malta (25%) measured at end-use (therefore including distribution losses) (Enemalta, 2010), whilst η_t represents the separate (gas heater-fed) thermal efficiency (85%). With LPG as the fuel used for trigeneration, c_{LPG} can be taken as 46.2 MJ/kg [19,862Btu/lb] (International Energy Agency, 2004). The results also discuss other operational factors such as the number of operating hours, cycling 'On'/'Off', *etc.*

$$PE_{PLT} = (\dot{m})c_{LPG} \quad [\text{kWh or Btu}] \quad (1)$$

$$PE_{SEP} = \frac{Q_e}{\eta_e} + \frac{Q_t}{\eta_t} \quad [\text{kWh or Btu}] \quad (2)$$

$$PES = \frac{(PE_{SEP} - PE_{PLT})100}{PE_{SEP}} \quad [\%] \quad (3)$$

Environmental Performance

Environmentally the performance of the two micro-trigeneration configurations was assessed by calculating the plants' CO₂ emissions (E_{PLT}) and their emission savings (ES), compared to the emissions emitted in equivalent separate generation (E_{SEP}) as shown in equations (4), (5) and (6). The term e_{LPG} is the emission factor for the LPG used by the micro-trigeneration unit (0.25kgCO₂/kWh [0.00016lbCO₂/Btu]), whilst e_e and e_t are the specific emission factors for the separate (grid-sourced) electricity (1.1kgCO₂/kWh [0.00071lbCO₂/Btu]) measured at end-use (Enemalta, 2010) and the separate (gas heater-fed) heat (0.25kgCO₂/kWh [0.00016lbCO₂/Btu]) respectively.

$$E_{PLT} = (PE_{PLT})e_{LPG} \quad [\text{kgCO}_2 \text{ or lbCO}_2] \quad (4)$$

$$E_{SEP} = e_e \left(\frac{Q_e}{\eta_e} \right) + e_t \left(\frac{Q_t}{\eta_t} \right) \quad [\text{kgCO}_2 \text{ or lbCO}_2] \quad (5)$$

$$ES = \frac{(E_{SEP} - E_{PLT})100}{E_{SEP}} \quad [\%] \quad (6)$$

Economic Performance

The economic performance of the two plant configurations was compared using the systems' calculated Present Worth (PW) (Biezma and San Cristóbal, 2006), considering a 25 year lifetime and a Minimum Attractive Rate of Return ($MARR$) of 6%, as shown in equation (7). The cash flow (CF) takes into account the costs and revenue flows from the

micro-trigeneration system and is a factor of the fuel costs, the grid-electricity tariffs and the applicable *FIT*.

$$PW = -I + \sum_{y=1}^Y \left(\frac{CF}{(1+MARR)^y} \right) \quad [€] \quad (7)$$

In the background section of the paper it was discussed how the sensitivity of the system to the electricity grid-electricity tariffs and fuel prices was analyzed by varying these two parameters. In this research a third variable parameter is being introduced, that is, the *FIT*. In the original research (Borg and Kelly, 2013) the electricity tariff was varied between $\pm 50\%$ of the current tariff, the price of LPG was varied between the local market low and high prices, whilst the *FIT* was kept constant at 0.5€ per electrical unit (kWh) exported. In this research the same variability is being maintained for the electricity tariffs and the fuel prices whilst the *FIT* is being varied between 0.5€ and 0.3€ per electrical unit (kWh) exported.

RESULTS

Table 2 and Table 3 show the energetic and environmental performance of the two plant configurations, with and without *SWH*, for a year worth of simulations.

Table 2. Energetic Performance for the two plant configurations

Plant Configuration	<i>PE_{PLT}</i>		<i>PE_{SEP}</i>		<i>PES</i>
	<i>kWh</i>	<i>Btu</i>	<i>kWh</i>	<i>Btu</i>	(compared to separate generation) (%)
Without <i>SWH</i>	72,167	246,233,804	127,584	435,316,608	43
With <i>SWH</i>	67,964	231,893,168	122,546	418,126,952	45
Percentage Difference	-6	-6	-4	-4	

Table 3. Environmental Performance for the two plant configurations

Plant Configuration	<i>E_{PLT}</i>		<i>E_{SEP}</i>		<i>ES</i>
	<i>kgCO₂</i>	<i>lbCO₂</i>	<i>kgCO₂</i>	<i>lbCO₂</i>	(compared to separate generation) (%)
Without <i>SWH</i>	18,627	41,166	35,248	77,898	47
With <i>SWH</i>	17,596	38,887	33,851	74,811	48
Percentage Difference	-6	-6	-4	-4	

If one considers the trigeneration systems on their own, that is, not in comparison with separate generation, adding a *SWH* accounts for an overall reduction in primary energy consumption of *approx.* 6%, with an equivalent difference in CO₂ emissions saved. This same reduction in primary energy consumption results in an improvement in primary energy savings compared to separate generation. In terms of operating hours, the trigeneration system with the *SWH* operated for 206 less hours, equivalent to 8.4% less hours per annum and cycled ‘On’/‘Off’ 28% less than the system working without the *SWH*. A reduction in cycling ‘On’/‘Off’ results in lower maintenance required.

In terms of their economic performance Figure 4 shows how the systems compare against variable fiscal parameters. In Figure 4a, the gas prices are held constant and the *PW* is calculated against varying electricity tariffs and *FIT*. It can be seen that the presence of a *SWH* effectively reduces the financial performance of the system. The reason behind this is the *approx.* 10% difference in gross electricity generated between the two plant configurations. Whereas, adding the *SWH* reduces the fuel consumption of the trigeneration unit, the resulting reduction in operating hours and hence the electrical output results in a lower electrical availability to satisfy the building’s own demand or to sell to the grid. It can also be observed that increasing the *FIT*, increases the difference between the two plant configurations. Again, the difference in electricity generated and the financial value of that electricity is the reason behind this difference.

Considering the case where electricity tariffs are constant and the fuel prices and *FIT* are varied (Figure 4b), it can be seen that although the difference in electricity generated by the two systems results in the system without *SWH* to be financially more feasible, at high fuel prices this difference starts to converge as fuel costs become more significant.

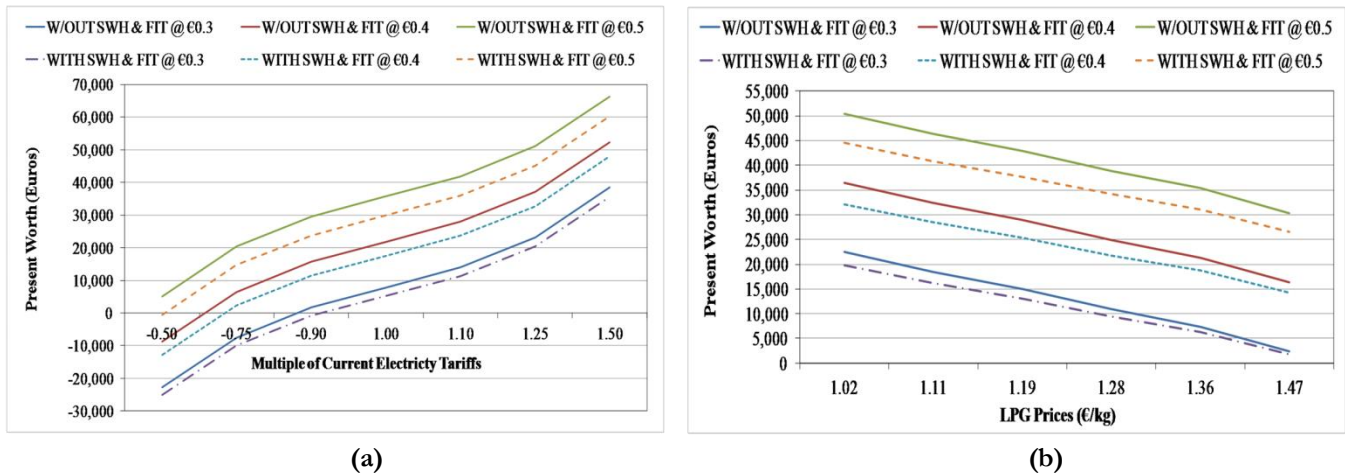

Figure 4 (a) *PW* with variable electricity tariffs and *FIT* but constant fuel prices (b) *PW* with variable gas prices and *FIT* but constant electricity tariffs

CONCLUSION

Research done on micro-trigeneration systems in residential buildings has proven that such systems can contribute to an overall improvement in energy-efficiency, with reductions in primary energy consumption and carbon emissions of about 40-50%. The specific savings obtainable are however case dependent, based on the particular operating conditions the system is working in. The research presented in this paper extends on previous work done on the subject and investigates the affect the installation of a solar water heater working in tandem with the micro-trigeneration system would have on the overall energetic, environmental and economic system performance. In this regard, the simulation-based research discussed in this paper has shown that, whereas the addition of a *SWH* system to the plant configuration improves the energetic and environmental performance of the trigeneration system – by improving the primary energy savings and the environmental savings by around 2-3%, the economic performance of a solar-assisted micro-trigeneration is negatively affected due to the reduction in the gross electricity generated by the system and that can be potentially exported to the grid. Moreover, it was shown that the financial performance of both systems is closely dependent on the applicable *FIT* – the higher the *FIT*, the higher the difference in the financial performance of the two systems.

NOMENCLATURE

- c = Calorific value
- CF = Cash flow
- e = Emission factor
- E = Emissions
- ES = Emission savings
- I = Investment
- η = Efficiency
- PE = Primary energy
- PES= Primary energy savings
- PW = Present worth
- Q = Energy demand (Electrical/Thermal)
- Y = Years

Subscripts

<i>e</i>	=	Electrical
<i>LPG</i>	=	Liquefied petroleum gas
<i>PLT</i>	=	Plant
<i>SEP</i>	=	Separate generation
<i>t</i>	=	Thermal

REFERENCES

- Abela, A., Hoxley, M., McGrath, P. and S. Goodhew. 2011. A comparative study of the implementation of the energy certification of residential properties in Malta in compliance with the Energy Performance of Buildings Directive. School of Architecture, Design and the Built Environment, Nottingham Trent University, UK
- ASHRAE. 2009. ASHRAE Handbook-Fundamentals. Atlanta: American Society of Heating Refrigeration and Air Conditioning Engineers, Inc.
- Biezma, M.V. and J.R. San Cristóbal. 2006. Investment criteria for the selection of cogeneration plants - A state of the art review. *Applied Thermal Engineering* **26**(5-6): 583-588
- Borg, S.P. and N.J. Kelly. 2011. The effect of appliance energy efficiency improvements on domestic electric loads in European households. *Energy and Buildings* **43**(9): 2240-2250
- Borg, S.P. and N.J. Kelly. 2013. High resolution performance analysis of micro-trigeneration in an energy-efficient residential building. *Energy and Buildings* **67**(12): 153-165
- Borg, S.P., Yousif, C. and R.N. Farrugia. 2005. Investigation of Domestic Solar Water Heating Installations in Malta. *Renewable Energies in Malta and beyond*, Salina, Malta
- Building Regulations Office. 2006. Malta Building Regulations, Part F - Conservation of Fuel, Energy and natural Resources. Minimum Requirements on the Energy Performance in Buildings, Ministry for Resources and Rural Affairs, Malta
- DEFRA. 2008. 'Market Transformation Programme'. Retrieved 08/04/2010, from: <http://efficient-products.defra.gov.uk/cms/market-transformation-programme/>.
- DOE. 2013. Buildings Energy Data Book. Chapter 1: Buildings Sector, from: <http://buildingsdatabook.eren.doe.gov/ChapterIntro1.aspx>.
- Enemalta Corporation. 2010. Enemalta Corporation Annual Report 2009 and Financial Statements 2008. Enemalta Corporation, Marsa, Malta. Retrieved: 10/09/2011, from: <http://www.enemalta.com.mt/enemaltastorage/images/files/annual%20reports/annual%20report%202009%20and%20financial%20statement%202008.pdf>
- Enerdata. 2012. Energy Efficiency Trends in Buildings in the EU. D. Bosseboeuf. Paris, France
- ESRU. 2005. ESP-r. Energy Systems Research Unit, Department of Mechanical and Aerospace Engineering, University of Strathclyde, Glasgow, UK
- Fragiacomo, P., Arcuri, P. and G. Florio. 2007. A mixed integer programming model for optimal design of trigeneration in a hospital complex. *Energy* **32**(8): 1430-1447
- International Energy Agency. 2004. Energy Statistics Manual. Paris, France
- Jordan, U. and K. Vajen. 2005. DHWcalc: Program to generate domestic hot water profiles with statistical means for user defined conditions. ISES Solar World Congress. Orlando, USA
- Khatri, K.K., Sharma, D., Soni, S.L. and D. Tanwar. 2010. Experimental investigation of CI engine operated Micro-Trigeneration system. *Applied Thermal Engineering* **30**(11-12): 1505-1509
- Lin, L., Wang, Y., Al-Shemmeri, T., Ruxton, T., Turner, S., Zeng, S., Huang, J., He, Y. and X. Huang. 2007. An experimental investigation of a household size trigeneration. *Applied Thermal Engineering* **27**(2-3): 576-585
- Piacentino, A. and F. Cardona. 2008. An original multi-objective criterion for the design of small-scale polygeneration systems based on realistic operating conditions. *Applied Thermal Engineering* **28**(17-18): 2391-2404
- Polonara, F., Arteconi, A. and C. Brandoni. 2009. Distributed generation and trigeneration: Energy saving opportunities in Italian supermarket sector. *Applied Thermal Engineering* **29**(8-9): 1735-1743
- REMODECE (Residential Monitoring to Decrease Energy Use and Carbon Emissions in Europe) Partners. 2008. REMODECE Database. IIEA Program Funded Project. Retrieved 01/12/2009, from: <http://www.isr.uc.pt/~remodece/database/login.htm>.