

Nanotechnology and Processes: Nano-Photovoltaic Panels as an Innovation in Energy Market

José Chavaglia^{*}, José António Filipe^{1#}, Manuel Alberto M. Ferreira^{2#}, Manuel Pacheco Coelho⁺

^{*}Instituto Universitário de Lisboa (ISCTE-IUL)
Lisboa Portugal
jnchavaglia@gmail.com

[#]Department of Quantitative Methods
Instituto Universitário de Lisboa (ISCTE-IUL), BRU – IUL
Lisboa Portugal

¹*jose.filipe@iscte.pt*

²*manuel.ferreira@iscte.pt*

⁺SOCIUS & ISEG/UTL – Portugal
coelho@iseg.utl.pt

Abstract— Nanotechnology can be a powerful weapon in creating competitive advantages in the energy market, through the use of the photovoltaic nano-panels, which may reduce production costs and simultaneously meet the socio-environmental requirements. It is a way to produce clean energy. Moreover, today the adoption of nanotechnology in energy production can make this kind of energy very interesting along the years, and fractal theory may help to show the effects. Nanotechnology may, in fact, be responsible for unimaginable gains, both economically and to preserve the planet.

Keywords - Nanotechnology, photovoltaic nano-panels, solar energy, process.

1. Introduction

In the new era in which competition has become global, technological innovations are the way to companies overcoming the challenges in the context of competition, by applying innovations to their production processes.

A run to technological innovations becomes quite visible, especially in the last decade in which the life cycle of products has decreased considerably. Many developments in terms of innovations have been seen in communications, medicine, robotics, computing,

energy or many other sectors of society.

It is very relevant to see the role that internet took over, the development of mobile devices, new medical imaging, the self-service centers, banks, etc. The truth is that people have become dependent on new technologies and companies became dependent on the process of constant search for innovation. But it is not possible to say in what extent this is vital. The fact is that just as some people do better professionally than others, some companies also do better in the competitive environment than others. Notably, in both cases, both individuals and companies that stand out have something in common: the ability to innovate.

This scenario is to highlight one of the great scientific revolutions in human history, nanotechnology, which opens up unimaginable possibilities in various fields of human reality and in various fields of science. Today the influence of nanotechnology can be seen in areas such as medicine (implantation of nano-robots, for example), agriculture (for pest control) or many others. The possibilities are endless on these fields.

The use of nanotechnology in the production processes of industry is evidenced in this article, in particular in the production of electric energy produced by photovoltaic panels. Emphasis is placed on the competitive advantage associated with the use of nanotechnology to solar energy production for companies in this market segment.

The American firm "Nanosolar", which studies are sponsored by major companies like Google or IBM, or resulting from the allocation of benefits offered by the Department of Energy, is leading the race for energy production derived from nanotechnology. It has named this technology as "nano-photovoltaic panels".

The use of this product has been showing a reduction in total costs on firms in relation to other types of solar energy, and meet government requirements and social use of energy from clean sources.

Despite the high feasibility for the economy and the environment, there are some considerations regarding the ethical and moral limits on nanotechnology that should be taken into account.

2. The Emergence of Nanotechnology

The first person to conceptualize Nanotechnology was Richard P. Feynman, although he has not used this term in his speech to the *American Physical Society* on December 29, 1959, where he made the first comments on the subject. The word "nanotechnology" was first used by Professor Norio Taniguchi (1974) to define the fabrication of a scale of 1 nm. Nanotechnology is the potential ability to create things from the smallest element, using the techniques and tools that are being developed today to place every atom and molecule in place. The use of nanometer implies the existence of a system of molecular engineering, which will likely generate the subversion of the factory manufacturing model as it is known.

However, nanotechnology will offer, in addition to products of higher quality at lower cost, a range of possibilities to produce new means of production and new types of resources and factors. This is a manufacturing system that could produce more manufacturing systems (plants that produce other plants) in a quick, cheap and clean way. The means of production may be reproduced exponentially. So in just a few weeks, power would pass from just some to several billion nanofactories. Thus, this represents a kind of revolutionary technology, manufacturing, powerful, but also with many potential risks, besides the benefits it has (see Euroresidentes, 2011, p. 01).

In Brazil, the budget of the Ministry of Science and Technology for the next four years is R680 million to this area. Overall it is estimated that only developed countries will allocate a sum of around USD 5.5 billion. An important example of successful

application of nanotechnology is *Empresa Brasileira de Agropecuária* (Embrapa). It has been working with nanotechnology in various research centers and has already released some products. One of the most notable is perhaps the "electronic tongue", a device that combines chemical sensors with nanometer-thick with a computer program which detects flavors and aromas and serve to quality control and certification of wines, juices, coffees and other products (see DIEESE, 2008, p. 03).

As suggested earlier, the subversion of the industrial model was directly related to the use of nanotechnology in the various branches of economic activities. However this study gives an outline for the manufacture of electric power, which generically McKibben considered itself as a country's economy (see McKibben, 2009, p. 24).

Nanotechnology is therefore contributing to the transformation of traditional models, being the way goods and services are produced, or in the way the production is conducted and made.

3. Nano-photovoltaic Panels as an Innovation

Companies need to be dynamic in the development of innovations and thus creating competitive advantages through its production processes so they can create economic value, and consequently generate their viability based on the market in which they operate. For McDonough III (2009, p. 04) "in the current buoyant economy, organizations must continually reinvent what they are and what they do [...]". This means that they need to constantly maintain market differentiation, through deliberate strategies in order to obtain competitive advantages that provide monopoly profits, even if temporary, in this environment that requires from companies a high degree of competitiveness.

The competition is part of a dynamic and evolutionary operation of the capitalist economy. The evolution of this economy is seen as over time based on an uninterrupted process of introduction and diffusion of innovations in a broad sense, ie any changes in the economic space in which these companies operate, whether changes in products, processes, sources of raw materials, forms of productive organization, or in their own markets, including in terms of geography (see Schumpeter, Brazilian version, 1982, p. 65).

According to McAfee and Brynjolfsson (2008, p. 78) "the result is that an innovator with a better way of doing things can grow at unprecedented speeds and dominate the industry".

In contrast, at the same time, which seeks a high level of competitiveness, it is understood that there is a need for companies to retain the existing common resources for their optimization in the future because we can no longer count on such a supply of natural resources to meet the continuing huge demand, given the level of production that humanity has achieved over the last century.

To Nogami and Passos (1999, p. 03), from the harsh reality of scarcity arises the necessity of choice. Since it is not possible to produce everything that people want, mechanisms must be created to somehow show to the societies the path to decide what goods to produce and what needs are met.

The concepts that are consistent with the possibility of economic and technological efficiency allow us to make an analysis of the act of production through the combination of forces and inputs in the production unit. All the means or methods of production indicate some of these combinations. Production methods vary in how such combinations occur, or by objects or by the combined ratio of their quantities. Every concrete act of production incorporates some combination thereof. It could also be considered as a combination enterprise itself, and even the production conditions of the whole economic system (see Schumpeter, 1982, p. 16).

The possibility of economic and technological efficiency reflects a producing combination of forces and inputs to reach an interesting production level for the company. All the means or methods of production indicate different combinations. Production methods vary in how such combinations occur, or by objects or by the combined ratio of their quantities. Every concrete act of production incorporates a kind of combination. A company can itself be considered a combination by itself, and even the production conditions of the whole economic system (see Schumpeter, 1982, p. 16).

Thus, it can be said that any company that uses clean energy in its production of goods and services, in particular the use of photovoltaic panels generated by nanopanels, generates competitive advantage by breaking the closed circle of the economy by creating a new mechanism of generation of market value,

since it is a new way to produce through a new combination of available resources.

In a direct way, besides the fact that the use of photovoltaics is already an innovation in itself, when it is combined with nanotechnology, its power of subversion, which can also be interpreted as its ability to break paradigms in the energy industry, takes the form of a powerful competitive weapon of production units.

Given this context, nanotechnology combined with solar energy production becomes interesting for the production units, whether public or private.

4. Deployment of a Photovoltaic system

4.1. Manufacture of a Nano-Solar Panel

In order to describe how a nanopanel is got, first semiconductor nanoparticles have to be produced (approximately 20nm of size, which is the equivalent of 200 atoms in diameter). Later, aluminum sheets are placed in presses, similar to those used in paper graphics. These aluminum sheets can be dynamic in the way they are used, due to their length and their width. This makes a product much more adaptable to the needed formats. After that, a thin layer of semiconducting ink is painted on aluminum substrate. Then another press deposits layers of cadmium sulfide and sulfur and zinc oxide (ZnO and CdS). Zinc oxide layer is non-reflective to ensure that sunlight is able to reach the semiconductor layer. Finally, the leaf is set in solar cells. Unlike other methods of manufacture of panels that require a special location for manufacturing, on this system nano-panels can be produced outdoors.

4.2. System Operation

To produce energy derived from solar radiation is necessary to understand the functioning of a photovoltaic cell. The photovoltaic solar energy is obtained through direct conversion of light into electricity, the so-called "photovoltaic effect" (see Becquerel, 1839, the discoverer of this effect).

The photovoltaic cell works when light reaches the photovoltaic panel and moves electrons which circulate freely from atom to atom, forming the electric current.

The photovoltaic cell is a practical application of photoelectric effect. When the light falls on certain

substances, takes off electrons that circulating freely from atom to atom, form a chain that can be stored. The photovoltaic cell that transforms the light into electricity will continue to generate power according to the level of radiation emitted, i.e. while the panel receive the light it will continue to generate electricity.

For Nascimento (2004, p. 02) "the photovoltaic cell does not store electrical energy, but maintains a flow of electrons established in an electrical circuit as long as there is light on it".

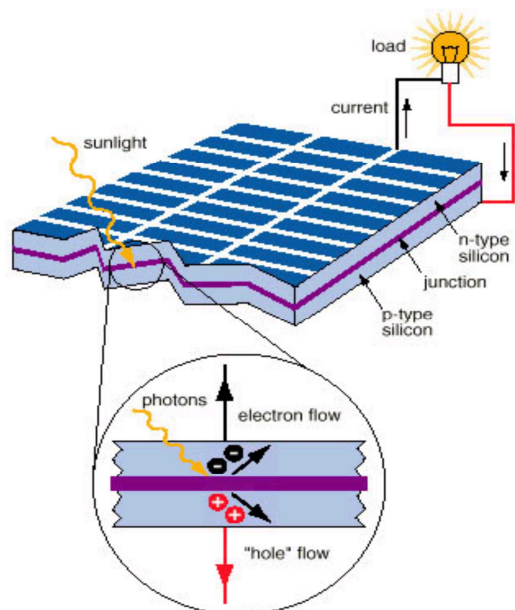

Figure 1- Energy Conversion

Direct conversion of solar radiation into electricity
(Source: Australian CRC for Renewable Energy Ltd)

4.3. The Installation of Photovoltaic System in a Company

A photovoltaic installation in an organization can be independent or have a connection to the electricity grid. For this connection to the network, it is necessary to establish a point of reception. The point is the point of power system network of the public service, which makes the connection of the installation. The sine wave inverter is used on systems connected to the power system network. Most homes use alternating current of 120 Volts 60 Hz. The sine inverter transforms the direct current photovoltaic system (ranging usually between 12Vcd-360Vcd) in 120 VAC, 60 Hz and synchronizes with the electrical network (see Figure 2).

The photovoltaic panels are easy to install, being a relatively simple process, regardless of the

installation location, since there is a flexibility in choice of location, especially with the use of nano-panels. There are several possible locations for its installation, such as rooftops, or even on the ground or in the buildings' painting. On the roofs, the support structure will be secured to the roof structure, or in the ink of the tiles and structures. For the panels installation on the ground a suitable structure should be used for fixing them to the ground.

In photovoltaic installation for enterprise consumption, the connection is made to the electrical system of the building of the production unit. Considering the photovoltaic installation, aiming to sell the surplus energy to private or public network, it is essential to record it in the system to account the power sent to the power grid. This record quantifies the energy that is released and the energy that is billed to the electrical network. The registry will preferably be close to the main electricity recording in the company.

Consequently, the materials used in photovoltaic network deployment have the same characteristics and the same lifetime of equipment already used in other electrical installations. They differ only in the batteries of energy that have a lifespan of 5 to 10 years and act as accumulators for use in schedules without the presence of solar radiation.

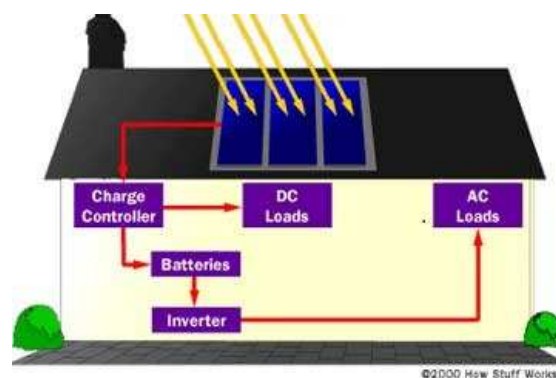

Figure 2 - Photovoltaic system installation.
Schema of a complete photovoltaic installation.
(Source: Toothman, J. and Aldous, S., 2000)

4.4. Costs of Solar Photovoltaic Energy

A company in a competitive market like the one of nowadays has necessarily to be very competitive. To be competitive, the company should prioritize the maximization of its profits, and the minimization of its cost of production.

In fact, a competitive advantage reflects a costs reduction in production. According to Varian (2006, p. 386) "the short-term cost function is defined as the minimal cost to achieve a given level of production, with only the adjustment of variable factors of production". Costs can be divided in two types, fixed costs and variable costs. Fixed costs are costs that remain constant, regardless of the degree of occupation of the productive capacity of the company. These costs derive from the very existence of the company. The variable costs are the costs arising from the degree of occupation of productive

factors on the company. For Sandroni (2007, p. 219) they are "a part of the total cost that vary according to the degree of occupation of the productive capacity of the enterprise: for example, cost of raw materials, wages for production and others".

Considering this, the cost arising from the use of photovoltaics fits both fixed costs (resulting from the installation, on equipment required for the generation of energy) but also fits into variable costs (resulting from the level of use of generated energy, varying accordingly to the allocation of resources and the level of production).

| Type of energy | Cost per kWh (R\$) | Cost per kWh (€) |
|-------------------------------|--------------------|------------------|
| Electric power network | 0,34 | 0,12 |
| Photovoltaics (silicon Panel) | 10,49 | 3,75 |
| Photovoltaics (nano-Panel) | 0,92 | 0,34 |

Figure 3 - Cost per energy type
(Source: Adapted from Scientific American 2008)

Considering figure 3, showing the costs relating to the use of some types of energy: the electricity from the public network, the solar photovoltaic energy through silicon panels and energy generated by photovoltaic nano-panels. The costs of solar power generated by nano-panels is between the other two ones. Therefore, cheaper energy means reduction of variable costs and this type may be a very competitive future type of energy.

Compared with the use of the energy supplied by the local public network, energy derived from solar panels still presents a higher cost of operation. However, the difference in costs between them has been dropping consistently and it happens even if compared to photovoltaic solar energy generated by silicon panels, which presents a much greater production cost than the energy generated by nano-photovoltaic panels. It can be also considered that there are extra costs generated by hydroelectric power that are subjective, because they affect the environment where the entrepreneur belongs. Allied to this, in Brazil a strong trend of increased costs with the production of hydroelectric power can be observed. In Brazil the total cost of energy

production has been performing considerably above the country's inflation in the period.

There is an advantage of using photovoltaic energy through the use of nano-panels once there are reasons that qualify the use of photovoltaic energy as a generator of competitive advantages in the market. The company that owns this type of technology is likely to have a reduction of its variable costs, when compared with the solar energy generated by photovoltaic silicon solar panels. There is also a perceived competitive advantage considering the conservation of the environment when it is compared with the energy provided by the local public network.

4.5. A New Opportunity for Power Generation Based on Nanotechnology

In addition to the already existent nano-panels, another opportunity to revolutionize the market is already in sight. Some scientists through a research in nanotechnology have developed devices capable of recharging nanoscale devices without the need for bulky quantities of energy provision as the battery and cables connected directly to the electric network.

To convert the mechanical energy of body motion, muscle stretching or water into electricity, there are "nanogenerators" that may make possible a new class of implantable medical devices, sensors and portable auto-feeding electronic devices (see Wang, 2010, p. 01).

The system works as follows: the current-producing nanogenerators flexion and then release zinc oxide nanowires that are simultaneously piezoelectric and semiconductors. In summary, nanogenerators convert mechanical energy into electrical energy. This is undoubtedly a giant step in the search for viable solutions to the economy and society in general in several areas.

Until now many possibilities derived from nanotechnology have been presented to the production of goods and services in the economy. However a great barrier to the full use of these devices has been in fact the power source, either by its absence by itself, and by replacing the energy storage system with batteries, because the existent ones are too expensive and generate a high degree of pollution when they are discarded. The impact of this change may be very considerable, for example, in the production of goods and services in isolated locations as it is the case of the Amazon region.

Being interesting for being used inside the body because the zinc oxide is not toxic, the nanogenerators could also be used whenever the mechanical power-hydraulic movement of either the sea water, the wind or the movement of a foot inside a shoe, for example, is available. Nanowires may grow on crystal substrates but not only, they can grow also in any film based on polymers. One day the use of flexible polymer substrates may allow portable devices to be powered by the movement of their users (see Wang, 2010, p. 02).

Of course this is just speculation yet. However it is a possibility to be considered in the future and would represent a revolution in the way man produces power and in the way people may satisfy some needs and consumers satisfy some desires.

5. Marketing representation through nanotechnology innovation in the energy sector

The importance of nanotechnology associated with energy production in industrial production is already considerable and evident. However a question hangs

in the air: is it possible to validate the benefits of the use of nanotechnology in the production of goods and services?

In fact, considering the nanotechnology used in energy production so far presented in market terms allows a new stage of development in the world economy. After all, goods just may be reproduced at big scales if they have marketing value.

"Theory of geometry of fractals" can be used to explain the possible performance of an innovation derived from the nanotechnology in the market.

Having into account the geometry of fractals, fractal is a word coined by Mandelbrot to describe the irregular geometry. It represents something fractured - from the Latin fractus, fractured source. Fractality is repeating geometric patterns in different scales, revealing increasingly smaller versions of themselves (Taleb, 2009, p. 321).

In quantitative terms, the fractal geometry is nothing more than numeric measurements which are, at least, partly preserved in different scales, and the proportions are kept the same.

The Mandelbrot set, widely used in association with chaos theory, allows us to consider some notes about this subject. For example, a set can be seen in smaller resolutions without ever reaching the threshold, even though the forms never be the same but smaller reproductions of themselves with small changes.

In mathematical and statistical terms, the fractal geometry has numeric measurements that are preserved in different scales.

Fractal geometry is referred on this economic phenomenon for explaining the consequences of the use of nanotechnology today in energy production that can generate a great effect in a few years. Yet it is from general knowledge that the accurate prediction of this effect is impossible to be measured.

In practice the fractal geometry can be presented in a simple example in this subject, using the philosophy of the example used by Taleb (2009, p. 293), explaining the difference between the Gaussian model and the Mandelbrotian model. Mandelbrotian model allows us to illustrate how the use that today is made from nanotechnology in electrical energy production can increasingly promote its use making it a long-term trend.

Consider, for illustration, the probability of getting rich in Europe, accepting for simplification of analysis that wealth in Europe is Mandelbrotian (scalable).

Tabela 1: Scalable Distribution

| Scalable distribution of wealth | |
|---|--------------|
| People with Liquid assets greater than 1 million Euro | 1 in 62,5 |
| Greater than 2 million Euro | 1 in 250 |
| Greater than 4 million Euro | 1 in 1000 |
| Greater than 8 million Euro | 1 in 4000 |
| Greater than 16 million Euro | 1 in 16000 |
| Greater than 32 million Euro | 1 in 64000 |
| Greater than 320 million Euro | 1 in 6400000 |

Source: Adapted from Taleb (2009).

As can be seen in table 1, in the course of the evolution of the probability process of wealth in no moment any event diminishes the intensity of the movement or trend. As wealth increases, the chance to get rich decreases. In mathematical terms, this implies the use of power laws. Note in the example of Taleb (2009), that the inequality between the super-rich is the same inequality between the simple-rich, i.e. the speed does not diminish.

Now let this to occur with the use of nanotechnology with the extensive use of photovoltaic nano-panels. The market acceptance could be something very similar to this effect, except that instead of the falling in probability occurs an increase, i.e. there is a scalable growth of the number of organizations that use solar photovoltaic energy of nano-panels.

In general terms, the use of nanotechnology for photovoltaic solar energy production can increase significantly, reflecting it a case of complete

acceptance of the technology. In other words, the tendency to spread on the market is considerable.

In summary, the photovoltaic nano-panels are economically efficient and environmentally friendly. Considering the economies of scale, the positive effects could be unimaginable and the effects very positive in the economy, businesses, or in the preservation of the environment. The development of this technology would permit to overcome one of the greatest problems related to solar energy, it would eliminate the need for large areas for the installation of photovoltaic panels. After all, nanotechnology ensures for example that the photovoltaic cells can be adjusted to the ink in the companies buildings.

6. Ethics and Nanotechnology

According to Richard Feynman (1959), the principles of physics do not speak against the possibility of manipulating things atom by atom; it would not be a violation of the law; it is something that, theoretically, can be done, but that, in practice, was never carried out because we are too big.

The new characteristics of nanotechnology raise some hypotheses about the possibilities and risks brought by this new technology. The materials are changed on a scale that is not visible to human beings, even with the aid of a conventional microscope. Just to show the type of change made on nanoscale, a big investment in scientific equipment is need (see DIEESE, 2008, p. 03).

In the development of new technologies - and nanotechnology is not different on this aspect - economic agents should have in mind the search for the creation of mechanisms to monitor and control the entire process, allowing the society to be aware of both, the positive possibilities and the possible problems arising from the adoption of nanotechnology in the production of goods and services in the economy.

The principle should be established: what will be controlled and who will make the implementation of the control to be done. After all, we will be talking about something invisible to human eyes, therefore, in this case all the details are important.

It is possible that what we are dealing with is not as simple as it seems, it is a unprecedented challenge in human history. For example, in cases of negative externalities derived from leaks of toxic waste into a

river, these problems are easily perceived. However, in terms of nanotechnology, this kind of perception will not be possible. This means that the public control of the events will be quite different from what exists today.

In order to have some balance between the control and the exploitation of resources with nanotechnology, the communication between the actors involved will be important, especially among companies which use it and in the society in general.

Finally, the monitoring of the role of nanotechnology in the relationship between business and society will be crucial, by submitting it to permanent ratings, especially in what concerns to the evident importance for economic development.

7. Conclusions

The possibilities that nanotechnology offer to humanity are very huge and cover all the possible ways people connect with each other and with the natural resources for the production of goods and services.

At first, the recognition that there are significant dangers when there is a wrong use of them is evident. These risks are materialized under the prism of problems arising from human nature itself, as corruption and bad faith, or over-exploitation of resources.

However, the benefits arising from the use of nanotechnology may break paradigms and may contribute significantly to satisfy consumption needs of humanity. These advantages can be visible in particular in terms of reducing costs and enhancing the quality of both the products and the production method, and can be particularly seen for example for the case of electric power production that is based on nano-photovoltaic panels.

The use of nanotechnology requires some precautions. There are risks involved. This always happens with any kind of a new available technology with so many possibilities of use and which contours are difficult to define. It is important to stress that the benefits are not only to the productive units, but for the society as a whole. Not using it would certainly bring to the humanity a reduction in wealth and quality of life. Anyway, the balance between costs and benefits may take into account all the relevant elements of the analysis.

Acknowledgments

This work was financially supported by FCT through the Strategic Project PEst-OE/EGE/UI0315/2011.

References

- [1] Aubin, J. P. (1979), *“Applied Functional Analysis”*. John Wiley & Sons Inc., New York.
- [2] Becquerel, A. E. (1968). *La Lumière, ses causes et ses effets*. Paris: Dominio Publico.
- [3] Campos, M. (2002). *História da ética*. Rio de Janeiro: Tecnoprint.
- [4] Chavaglia, J. N. (2010). *Energia solar fotovoltaica como vantagem competitiva em empresas industriais da Amazônia: ganhos de eficiência da empresa e preferências do consumidor*. Lisboa: ISCTE/IUL.
- [5] Chavaglia, J. N. (2009). *Sucesso Profissional: as seis habilidades*. São Paulo: Barauna.
- [6] Departamento Intersindical de Estatística e Estudos Sociais - DIEESE. (2008). *Nanotecnologia: conhecer para enfrentar os desafios. Nota Técnica*.
- [7] Euroresidentes. (2011). *Introdução a Nanotecnologia: O que é Nanotecnologia*. Available in www.euroresidentes.com, assessed on 26 January 2011.
- [8] Filipe, J. A. (2009). A note on the drama of the commons. How to deal with an old problem in natural resources: The resources overexploitation. *International Journal of Academic Research*.
- [9] Filipe, J. A. (2006). *O drama dos recursos comuns. Um caso de aplicação da teoria dos jogos aos comuns da pesca*. Lisboa: PhD thesis ISCTE.
- [10] Filipe, J. A., Coelho, M. F., and Ferreira, M. A. (2007). *O drama dos recursos comuns*. Lisboa: Edições Sílabo.
- [11] Filipe, J. A., Ferreira, M. A. M., Coelho, M. and Pedro, M. I. (2010), *Managing Complexity: a Problem of Chaos in Fisheries Policy*. *China-USA Business Review*. David Publishing Company, Chicago, IL, USA. 9 (3) / pp. 15-24.
- [12] Filipe, J. A., Ferreira, M. A. M., Coelho, M. and Chavaglia, J. N., *Nanotechnology: Overpassing the limits of the human being. An ethical discussion applied to medical applications*, in Silva, N. and Costa, G. J. M. (Ed.), *Ethical*

- Dimensions in Bio-Nanotechnology- Present and Future Applications in Telemedicine*, Hershey, USA: IGI Global. Forthcoming.
- [13] Hansenclever, L., and Kupfer, D. (2002). *Economia industrial*. Rio de Janeiro: Campus.
- [14] IBGE. (2008). *O Brasil em numeros*. Rio de Janeiro: IBGE.
- [15] Ikki, O. (2006). *National survey report of PV power applications in Japan*. Tóquio: International Agency Energy.
- [16] Mateache, A. G. (s.d.). El parque solar más grande del mundo está en lá Mancha. *Mundo Magazine*.
- [17] McAfee, a., and Brynjolfsson, E. (2008). Diferença competitiva. *Havard Business Review*.
- [18] Mcdonough III, E. F., Zach, M. H., Lin, H.-E., and Berdrow, I. (2009). Integrando a inovação e o conhecimento na estratégia. *Revista Portuguesa e Brasileira de gestão*.
- [19] Mckibben, B., Rogers, J., and Nijhuis, M. (2009). *National Geographic*.
- [20] Mckibben, B., Rogers, J., & Nijhuis, M. (2009). *National Geographic*.
- [21] Nascimento, C. A. (2004). *principio de funcionamento da célula fotovoltaica*. Lavras: UFL.
- [22] Nogami, O., and Passos, C. R. (1999). *Princípios de economia*. São Paulo: Pioneira.
- [23] Peters, T. (1998). *O círculo da inovação*. São Paulo: Harbra.
- [24] Pindyck, R., and Rubenfield, D. (1994). *Microeconomia*. São Paulo: Makron Books.
- [25] Sandroni, P. (2002). *Novíssimo dicionário de economia*. São Paulo: Best Seller.
- [26] Schumpeter, J. A. (1982). *Teoria do desenvolvimento economico*. São Paulo: Abril Cultural.
- [27] Silva, A. C. (2003). *Nanotecnologia: uma iniciativa recomendada pela aeronáutica*. Acesso em 26 de Janeiro de 2011, disponível em www.defesabr.com.br.
- [28] Taleb, N. N. (2009). *A Lógica do Cisne Negro*. Rio de Janeiro: Best Seller.
- [29] Toothman, J.; Aldous, S. (2000), How solar cells work. Retrieved from <http://science.howstuffworks.com/environmental/energy/solar-cell.htm>.
- [30] Varian, H. R. (2006). *Microeconomia: princípios básicos*. Rio de Janeiro: Campus.
- [31] Vásques, A. S. (1982). *Ética*. Rio de Janeiro: Civilização.
- [32] Wald, M. L. (2008). O charme e o poder das renováveis. *Scientific american*. Brazil. Special Edition 32.
- [33] Wang, Z. L. (2010). *Nova Técnica para alimentação de dispositivos em escala nanométrica sem a necessidade de fontes de energia volumosas*. Available in <http://www.azonano.com/news.aspx?newsID=2149&lang=pt>. Assessed on 14 February 2011.
- [34] Webber, M. E. (2008). Uma questão de opção. *Scientific american*. Brasil, São Paulo: Duetto.
- [35] Wissing, L., Forschungszentrum, J., and Projekttrager, J. (2006). *National Report of PV power applications in Germany*. International Agency Energy.
- [36] Zweibel, K., Mason, J., and Fthenakis, V. (2008). Energia solar. *American Scientific*. Brasil, São Paulo: Duetto.