

---

MALTA ARCHAEOLOGICAL REVIEW SUPPLEMENT 1

---

# Pottery from Roman Malta



Maxine Anastasi



---

MALTA ARCHAEOLOGICAL REVIEW SUPPLEMENT 1

---

# Pottery from Roman Malta

Maxine Anastasi

with contributions by

David Cardona and Nathaniel Cutajar



ARCHAEOPRESS PUBLISHING LTD  
Summertown Pavilion  
18-24 Middle Way  
Summertown  
Oxford OX2 7LG

[www.archaeopress.com](http://www.archaeopress.com)

ISBN 978-1-78969-329-4  
ISBN 978-1-78969-330-0 (e-Pdf)

© Maxine Anastasi and Archaeopress 2019

Cover illustration © Department of Classics and Archaeology, University of Malta



This work is licensed under a Creative Commons Attribution 4.0 International License.  
Printed in England by Severn, Gloucester

This book is available direct from Archaeopress or from our website [www.archaeopress.com](http://www.archaeopress.com)

## Contents

List of figures .....	ii
List of tables .....	iii
Foreword .....	v
Acknowledgements .....	vii
Introduction .....	1
Past ceramic research .....	1
Methodology .....	2
Quantification .....	2
Chronology .....	3
Classification criteria .....	4
The sites and their assemblages .....	5
Bulebel, Malta (compiled together with N. Cutajar) .....	5
The pottery assemblage from Bulebel .....	5
Foreman Street, Rabat, Gozo (compiled together with N. Cutajar) .....	9
The pottery assemblage from Foreman Street, Gozo .....	9
Melita Esplanade, Rabat, Malta (compiled together with D. Cardona) .....	12
Stratigraphic report for Melita Esplanade .....	13
The pottery from the Melita Esplanade .....	19
Local Maltese potteries .....	21
Chronology and a discussion of the import trends .....	24
Early Roman period .....	24
Mid-Roman period .....	25
Later Roman period .....	27
General conclusion .....	30
Local Maltese fabrics .....	32
Geology of the Maltese Islands .....	32
A Classification of Maltese fabrics .....	34
Local Fabric 1 .....	35
Local Fabric 2 .....	35
Local Fabric 3 .....	37
Local Fabric 4 .....	37
Local Fabric 5 .....	37
Local Fabric 6 .....	39
Local Fabric 7 .....	39
Catalogue of pottery .....	40
Catalogue structure .....	40
Amphorae (A1-A24) .....	40
Punic-period amphora forms (A1) .....	40
Roman-period amphora forms (A2-A4) .....	42
Imported amphorae (A5-A24) .....	45
Fine wares (B1-B41) .....	58
Local fine wares (B1-B27) .....	58
Local red-slipped wares (B1-B22) .....	58
Local thin-walled wares (B23-B27) .....	67
Imported fine wares (B28-B42) .....	70
Cooking wares (C1-C51) .....	77
Local cooking wares (C1-C20) .....	77
Local ollae (C1-C7) .....	77
Imported cooking wares (C20-C27) .....	85
Coarse wares (D1-D80) .....	103
Local coarse wares (D1-D80) .....	103
Lamps (L1-L2) .....	155

Miscellaneous vessels (M1-M6) .....	157
<b>Appendix 1: Catalogue entry concordance</b> .....	<b>159</b>
<b>Appendix 2: Pottery quantification</b> .....	<b>166</b>
<b>References</b> .....	<b>171</b>

## List of figures

Figure 1: Location map of Malta and sites mentioned in text. ....	3
Figure 2: (top) Aerial view of south-east Malta indicating the location of the Bulebel site and other sites in the area (source: Google Earth); (bottom) Plan of the Bulebel quarry site .....	6
Figure 3: Stratigraphic matrix for the Bulebel excavation.....	7
Figure 4: a) Aerial view of Rabat, Gozo, indicating the location of the Foreman Street site and key surrounding sites; b Number (RBH) of predominant local coarse ware types identified at Foreman Street (n=732). ....	10
Figure 5: Plan of the Melita Esplanade trench showing the structures discovered .....	13
Figure 6: Stratigraphic matrix for the Melita Esplanade excavation.....	14
Figure 7: West-facing elevation of wall 1040 .....	15
Figure 8: Detailed plan of interior floor levels within Structure A .....	16
Figure 9: West-facing section drawing of interior of Structure A .....	17
Figure 10: Section drawings of cistern 1044 .....	18
Figure 11: Aerial view of Mdina and Rabat, Malta, indicating the location of other Roman-period remains and finds; and (bottom) a plan of the Roman domus and other houses excavated in Rabat, Malta .....	20
Figure 12: (top) Amphorae types (based on RBH); and comparison between count of walls, RBH and combined total for amphora in Phases 1 (bottom left) and 2 (bottom right) at Bulebel (n=309).....	25
Figure 13: Number of diagnostic amphora types identified at Melita (n=102). ....	26
Figure 14: Comparison between count of walls, RBH and combined total for amphorae in Phases 1 (left) and 2 (right) at Melita (n=61). ....	26
Figure 15: Quantity (based on RBHS) of amphorae from Foreman Street (n=99). ....	27
Figure 16: Quantification of fine wares from the three sites. ....	28
Figure 17: Comparison between count of walls, RBH and combined total for amphorae in Phases 3-5 at Melita (n=174).....	29
Figure 18: Quantification of cooking wares from the three sites. ....	29
Figure 19: Schematic diagram showing the five main geological layers of the Maltese islands. ....	32
Figure 20: Possible sources and types of inclusions in Maltese pottery fabrics.....	33
Figure 21: The thickest Greensands outcrop, il-Gelmus hill, on Gozo. The outcrop is a short distance from the Foreman Street site. ...	34
Figure 22: Local Maltese fabrics 1-2. ....	36
Figure 23: Local Maltese fabrics 3-7. ....	38
Figure 24: Local Punic and Roman amphorae (A1-A2).....	41
Figure 25: Local and imported Punic and early Roman amphorae (A2-A9).....	43
Figure 26: Imported early Roman amphorae (A9-A10).....	47
Figure 27: Detail of possible stamp on an imported Lamboglia 2 amphora (A10.2) from Bulebel. ....	48
Figure 28: Imported amphorae (A10-A11).....	49
Figure 29: Imported amphora (A11).....	50
Figure 30: Imported east Sicilian amphorae (A12-A13). ....	51
Figure 31: Imported amphorae (A14-A23).....	56
Figure 32: Miscellaneous imported amphorae (A24).....	57
Figure 33: Local red-slipped ware (B1-B7).....	60
Figure 34: Local red-slipped bowl forms (B1 and B4). ....	62
Figure 35: Local red-slipped ware forms (B8-B12). ....	63
Figure 36: Local red-slipped ware forms (B13-B20). ....	66
Figure 37: Local red-slipped and thin-walled ware forms (B21-B27).....	68
Figure 38: Imported thin-walled ware (B28-B32), black-slipped ware (B33-B35), and Italian terra sigillata (B36).....	73
Figure 39: Imported red-slipped ware forms (B37-B40).....	74
Figure 40: Imported red-slipped ware forms (B40-B41).....	76
Figure 41: Local cooking ware forms (C1-C7).....	79
Figure 42: Local cooking ware forms (C8-C14).....	81
Figure 43: Local handmade ware forms (C15-C16).....	83
Figure 44: Local handmade and painted wares (C16, C19 and D34.1). ....	84
Figure 45: Local handmade ware forms (C16-C17).....	86
Figure 46: Local handmade ware forms (C18-C19).....	87
Figure 47: Imported cooking ware forms (C20-C25).....	88
Figure 48: Imported cooking ware forms (C26-C31).....	91
Figure 49: Imported cooking ware forms (C31-C33).....	94

Figure 50: Imported cooking ware forms (C34-C38).....	95
Figure 51: Imported cooking ware forms (C39-C40).....	98
Figure 52: Imported cooking ware forms (C40-C45).....	99
Figure 53: Pantellerian cooking ware forms (C46-C47).....	102
Figure 54: Pantellerian cooking ware forms (C48-C51).....	104
Figure 55: Local coarse ware bowls, types D1-D5.....	107
Figure 56: Local coarse ware bowl forms (D6-D9).....	109
Figure 57: Local coarse ware bowl forms (D9-D10).....	110
Figure 58: Local coarse ware bowl forms (D11-D12).....	113
Figure 59: Local coarse ware bowl forms (D13-D15).....	115
Figure 60: Local coarse ware bowl forms (D16-D21).....	117
Figure 61: Local coarse ware bowl (D22) and plate (D23-D26) forms.....	119
Figure 62: Local coarse ware plate forms (D26-D28).....	120
Figure 63: Local coarse ware bowl forms (D29-D31).....	123
Figure 64: Painted coarse ware bowl forms (D32-D34).....	124
Figure 65: Painted coarse ware plate form D35.....	125
Figure 66: Coarse ware large bowl forms (D36-D37).....	127
Figure 67: Coarse ware large bowl forms (D38-D40).....	128
Figure 68: Coarse ware large bowl forms (D40-D42).....	131
Figure 69: Coarse ware large bowl forms (D42-D45).....	132
Figure 70: Coarse ware large bowl forms (D45-D49).....	134
Figure 71: Large coarse ware bowl (D50) and plate (D51) forms.....	135
Figure 72: Coarse ware mortar base (D52).....	136
Figure 73: Miscellaneous large open coarse ware vessels (D53).....	137
Figure 74: Coarse ware jar forms (D54-D55).....	138
Figure 75: Coarse ware jug and jar forms (D55-D57).....	139
Figure 76: Coarse ware jug and jar forms (D58-D62).....	142
Figure 77: Complete examples of jars (types D60 and D61) and a warped bowl possibly belonging to type D11, on exhibit at the National Museum of Archaeology, Gozo.....	143
Figure 78: Coarse ware jug and flask forms (D63-D67).....	145
Figure 79: Round-mouth jar (D64) from an underwater context off the coast of Xlendi Bay, Gozo.....	147
Figure 80: Coarse ware juglet (D66.1) from Bulebel tomb 3.....	147
Figure 81: Miscellaneous coarse ware jug and flask forms (D67-D69).....	148
Figure 82: Coarse ware storage jar forms (D70-D71).....	149
Figure 83: Coarse ware storage jar forms (D72-D74).....	151
Figure 84: Dolia forms (D75-D79).....	153
Figure 85: Imported unguentaria (D80).....	154
Figure 86: Local closed lamp forms (L1-L2).....	156
Figure 87: Miscellaneous coarse ware forms (M1-M6).....	157

## List of tables

Table 1: The chronological divisions of assemblages used for the analysis in this study.....	4
Table 2: Number and percentage (RBHS) of imported and local pottery; and the proportion of imported versus local pottery from the Q3 assemblage at Bulebel (n=2408).....	8
Table 3: Amphorae types from Bulebel.....	8
Table 4: Number and percentage (RBHS) of imported and local pottery; and the proportion of imported versus local pottery from Foreman Street (n=3621).....	11
Table 5: Number and percentage (RBHS) of imported and local pottery; and the proportion of imported versus local pottery from Museum Esplanade, Rabat, Malta (n=1461).....	21
Table 6: Amphorae types from the Melita Esplanade.....	22
Table 7: Number of ARS fragments from the three assemblages (RBHS).....	76





## Foreword

The publication of Maxine Anastasi's *Pottery from Roman Malta* marks two firsts: it is the first in a new monograph series which complements the journal of The Archaeological Society Malta, the *Malta Archaeological Review* (ISSN 2224-8722); it is also the first exhaustive publication of pottery groups to reap the fruits of two developer-funded stratigraphic excavations carried out in Malta and Gozo respectively in recent years. The third site which produced pottery studied in this volume, from Rabat (Malta), was investigated in the early 1980s by an expedition from UCLA but it remained little known and the pottery unpublished. The study was supported by the Superintendence of Cultural Heritage (Malta) and Heritage Malta.

The aim of the supplement series is to provide an opportunity for publication of more substantial works of monograph length (well beyond the scope of articles published in the Review itself) and for proceedings of collective works on particular themes arising from conferences, seminars or workshops, or edited volumes. Following the editorial policy of the Review, Supplements shall focus on the archaeology of the Maltese Islands or topics on areas of the Mediterranean of direct relevance to the archipelago. All volumes are anonymously peer reviewed.

The Archaeological Society Malta is grateful to Agapi Trust and APS Bank plc, sponsors who have made it possible not only to publish this monograph but to make it available online for free through Archaeopress. This is being done in the belief that Anastasi's work, with its useful catalogue of pottery fragments numbering about 7500 pieces, deserves to reach as wide an audience as possible as it constitutes an important benchmark for ceramic specialists and other scholars interested in the central Mediterranean in the time period 1st century BC – 4th century AD.

Nicholas C. Vella  
Editor, Malta Archaeological Review Supplementary Series

Patricia Camilleri  
President, The Malta Archaeological Society



## Acknowledgements

As is often the case, one's work is rarely carried out in isolation, but rather within a community of colleagues, friends and family members who, often without even realizing it, provide such integral support and assistance necessary for making studies such as this possible. With this in mind, I wish to thank a great many people who have helped me along the way. My initial study was conceived by a stubborn desire to contribute in a meaningful and useful way, to filling what I felt was a yawning gap in our collective knowledge of the Roman period ceramic repertoire from the Maltese islands.

In order to reach this stage, however, I owe a great deal of gratitude to all those who throughout the years, shared their expertise with me, or patiently allowed me to shadow them during their various pottery study campaigns. I wish to thank Paul Arthur, Babette Bechtold, Nathaniel Cutajar, Roald Docter, Chris Doherty, Carmela Franco, Philip Kenrick, Victoria Leitch, Alessandro Quercia, Paul Reynolds, Claudia Sagona, Karin Schmidt, Davide Tanasi, and Hanni Töpfer for this reason.

After completing a research Masters at the University of Malta in 2010, I was able to continue studying local pottery assemblages as part of my doctoral research at the University of Oxford, between 2011 and 2015. The material presented here is a result of these studies.

Part of my time at Oxford was generously funded by the St Cross Graduate Scholarship in Archaeology, together with another generous stipend I received through the Alice Reece Foundation, of which I am extremely grateful to Dr Richard Reece who believed in my research, and supported my application.

My DPhil supervisor, Andrew Wilson, was integral to encouraging and supporting me throughout the original research and drafting of my thesis. I am particularly grateful for his careful guidance, patience and enthusiasm, which were never in short supply, and which were essential for maintaining the motivation required for completing such a daunting task.

Back home on Malta, I owe a great deal of gratitude to Nicholas Vella for his role as mentor, troubleshooter, and above all else, friend throughout my studies. The Maltese ceramic assemblages from Bulebel and Foreman Street, which I analyzed, were kindly entrusted to me by Nathaniel Cutajar (former Deputy Superintendent of Cultural Heritage, Malta). The additional support and enthusiasm he showed towards this project, and the many hours we spent discussing Maltese ceramics together most certainly enriched this whole process. I am also very thankful to David Cardona and Sharon Sultana (both Senior Curators at Heritage Malta) for granting me access to the Museum Esplanade material and excavation archive. During the actual fieldwork study, I was very fortunate to have many helping hands who facilitated and speeded up the laborious process of cleaning, inking, sorting and counting the pottery sherds. I would like to thank Luke Brightwell, Ricoh Davies, Dwayne Haber, and Kay Mallia, all (now former) University of Malta students, for their generous time and much needed assistance. I am also so grateful to my close friends Patsy Chetcuti, Katie Delicata and Charlene Camilleri Duca for choosing to help work on the pottery with me so that I could spend some time with them during my busy and fleeting visits to Malta.

Thank you Abi, Gianni, Stefany, Ed, Peter, Nichole, Erica, Madhuri, Morgan, Mary and Javi for being such wonderful friends and making the tedium of DPhil life bearable, offering endless encouragement and being such reliable pub companions!

I received the best start possible to my Oxford venture from my UK-residing family, in particular through the generous help given by Aunt Valerie and Nicola. And also, I am very grateful to Carol and Trevor Lloyd for their generous hospitality during the last year of my studies. I would also be in a very different place had it not been for David who has been my rock throughout the good and not-so-good times that accompany any prolonged period of solitary research.

More recently, I am grateful for to the Malta Archaeological Society committee headed by the President, Ms Patricia Camilleri, for supporting and agreeing to publish this contribution. Particular thanks is also extended to Ann Gingell Littlejohn for carefully reading through an advanced draft of this manuscript.

Finally, I could not have completed anything without the unwavering backing of my long-suffering family. The financial, emotional and practical support given by Michael, my brother Nigel, my late father Mark and most of all my mother Nathalie, has been endless and unquestionable.

Maxine Anastasi  
31 July 2019  
Msida, Malta



## Introduction

Research into the Maltese island's material culture, particularly pottery, has been steadily increasing over the last few decades, albeit glaring lacunae still exist. It is within this context that the present study was structured with the primary aim of presenting a detailed analysis and catalogue of Roman-period pottery from the Maltese islands. The work forms part of a larger doctoral study aimed at understanding the economic role of the Maltese islands within the wider Central Mediterranean region during the Roman period (Anastasi 2015). The study includes pottery from all classes from stratified assemblages with the intention of providing a chrono-typological catalogue of local and imported material ranging from the first century BC to the mid-fourth century AD.

The impetus for making this research accessible is primarily derived from the lack of pottery reports detailing form and fabric information for local and imported amphorae, fine wares, cooking ware and coarse wares from Maltese contexts. With this in mind, it is intended as a starting point for bringing together the disparate strands of Roman ceramic forms that are known on the island, but have not been afforded the same level of study that has been subjected to prehistoric, Phoenician and Punic-period pottery found on the island. Pottery is very often one of the only means of dating an archaeological site. For pottery to be an effective way of dating Roman-period sites, it is imperative that as many forms of locally produced and imported pottery are identified, sourced and ultimately dated as well as possible. This is obviously highly ambitious and susceptible to numerous obstacles such as the context of the assemblages studied, but also the impracticality, or in many instances, lack of opportunity to be able to test and modify interpretations subject to new discoveries being made.

Finding the 'right' assemblages to study is an additional issue that is often faced. Experience in the field has demonstrated that Roman-period local pottery tends to be fairly similar to Late Punic-period material. This is compounded by a tendency for ancient Maltese inhabitants to prefer locally made coarse ware vessels over more recognizable Mediterranean imports, which are in general much easier to source and date than local regional productions. Despite this, the present work is a first attempt at presenting a Roman-period pottery catalogue for an entire assemblage, and the economic trends that can be detected over time beyond those of just amphorae.

What follows is a brief overview of the most recent and comprehensive studies that have contributed to our knowledge of Maltese Classical-period pottery

published to date. This is followed by an overview of the site information, the pottery types identified within the assemblages and a discussion of the observed economic trends. A detailed catalogue of the primary fabrics identified during the study, as well as an illustrated catalogue of all the classes of pottery are then presented.

### Past ceramic research

Research and rescue-led excavations carried out over the last century and a half have resulted in an accumulation of a significant corpus of Classical-period pottery fragments from a variety of urban, domestic, funerary and ritual contexts. The most significant of these remain the three archaeological missions<sup>1</sup> led by the University of Rome 'La Sapienza' at the multi-period site of Tas-Silġ, the San Pawl Milqi villa and the Punic sanctuary at Ras il-Wardija, Gozo, between 1963 and 1970 (see relevant sections of the *Missione's* preliminary reports; Bonello *et al.* 1964; Bozzi *et al.* 1968; Busuttill *et al.* 1969; Cagiano de Azevedo *et al.* 1965; 1966; 1967; 1972; 1973); and the quasi-systematic collection and recording of hundreds of rock-cut tomb contexts, mostly dated to the Punic and early Roman period. The majority of these were discovered during urban and rural building works throughout the 20th century (see Sagona 2002 for a gazetteer of the tomb discoveries).

The Italian *Missione* routinely published preliminary annual reports of their investigations, in which key pottery finds were listed and illustrated. However, a systematic study of the ceramic material never materialised. Instead, smaller studies of particular classes were published several decades later. These include: B. Bruno's detailed quantified and petrographic study on local and imported amphorae from Tas-Silġ and San Pawl Milqi for the Late Punic, Roman and Byzantine periods (Bruno 2002; 2004; 2009; Bruno and Capelli 2000); and A. Quercia's three seminal studies on Punic-period cooking wares (2000; 2002), coarse wares (2004-2005; 2011), and Pantellerian ware (2006), all from the sanctuary of Tas-Silġ. Similar studies on the Punic and Roman fine wares and Roman-period cooking and coarse wares from the same sites remain to be undertaken. Indeed, pottery other than the amphorae from San Pawl Milqi, possibly one of the most important and well-known oil-producing Roman villas on the island, remains to be studied in full. Other than the *Missione's* three excavations, only one other site assemblage has undergone some form of study, the brief, yet detailed, analysis of the residual Roman

<sup>1</sup> Hereon, the Italian archaeological mission (*missione archeologica italiana*) will be referred to as the *Missione*.

pottery from the Medieval chapel at Ħal Millieri, Malta (Blagg, Bonanno and Luttrell 1990).

Pottery from Punic and Roman tombs has been subjected to a number of studies, particularly focusing on the Phoenician and Punic period of Malta (Ciasca 1985a-b; 1999; Culican 1982; Vidal González 1996). The most comprehensive and valuable funerary study remains that by C. Sagona who systematically studied and catalogued all the pottery from the known Phoenician, Punic and Roman tomb contexts (Sagona 2002).

More recently, a selection of pottery finds from the joint Belgo-Maltese fieldwalking survey in the north of Malta (2008-2010) was included in a detailed preliminary report of the exercise, and provided much-needed data on the distribution of Classical-period pottery on the island (Docter *et al.* 2012). The ceramic material from the University of Malta's excavations at Tas-Silġ (1996-2005) has also recently been published (Sagona 2015), offering crucial information on the Late Punic repertoire of the island. In spite of all this, however, knowledge of the local and imported repertoire of pottery for the Roman period is greatly lacking. Aside from Bruno's study on amphorae, no comprehensive publications on the Roman pottery from Malta have been forthcoming. Fortunately, this situation is slowly changing. Renewed excavations by the University of Malta at the olive oil-producing site at Żejtun has propelled ceramic research, both for the Punic (Vella *et al.* 2017; Bechtold 2018) and Roman periods (Anastasi 2010; 2012). Important new assemblages are currently undergoing study from the University's 2005-2010 excavations at a small rural site at Għar ix-Xiħ, Gozo (Quercia and Anastasi 2008-2009), whilst a comprehensive list and assessment of Roman-period African pottery found in Maltese contexts, building on the survey by J. W. Hayes (1972), has also now been published (Anastasi 2016) and offers valuable new insights into the material culture of Malta's Roman past. It is within this context that the present research developed.

## Methodology

The unpublished pottery assemblages presented here come from three Maltese sites of Roman date: Bulebel, on the outskirts of Żejtun; the Melita Esplanade in Rabat, (both in Malta) and Foreman Street, in Rabat, Gozo (Figure 1). Altogether, the three assemblages amounted to 10,838 sherds, which after visual examination made up a total of 7,494 individual vessels. The Minimum Number of Individuals (MNI) was calculated on the basis of visual examination of the fabric, form morphology and assessing whether sherds joined together.<sup>2</sup> A x20

handheld magnification lens was used to identify the different fabrics and further group sherds into different types within the separate class groups (amphorae, coarse wares, cooking wares and fine wares). The details of each sherd were included in an Excel database, which recorded all the form, fabric and comparative details relevant to each piece. Diagnostic fragments that were representative of a specific type were given a Special Find (SF) number, or unique record number for the case of the Melita material, and were recorded in greater detail, illustrated and photographed. All of the sherds were counted and these data used for quantification purposes (see Appendix 2).

The presentation and layout of the catalogue is modelled off the publication of the coarse and fine ware pottery from Sidi Khrebish (Berenice) by John N. Dore (1979) and Philip M. Kenrick (1985) respectively. The material is divided into four main groups: amphorae, fine wares, cooking wares, and coarse wares. Within each group, the representative fragments were further divided according to the following criteria: 1) source and provenance (whether locally produced or imported to Malta; when possible, the provenance of the imported fragments was identified through comparisons); and 2) form (mainly the functional shape such as bowl, plate, jar, amphora etc.). The criteria within each group were however adjusted to take into consideration typological distinctions that are more apparent in one group rather than another.

## Quantification

The sample sizes for the Bulebel (n=2408), Melita (n=1461) and Foreman Street (n=3621) assemblages are relatively small when compared against other pottery assemblages from local and foreign sites. To maximise the usefulness of the data, all sherds, including wall sherds (rims, bases, handles and wall sherds: RBHS) that represent an individual vessel were included in the data quantification charts. In some instances, wall sherds that belonged to clearly imported vessels were not represented by a diagnostic sherd such as a rim, base or handle. Identifying residuality was an additional problem. In an attempt to overcome this bias, the amphorae data were presented in a variety of formats. As an example, the chart representing the Bulebel amphorae (Figure 12, top) illustrates the number of diagnostic sherds (RBH), which can be identified typologically. This first method was adopted so clear types known for their general provenance, chronology and contents could be traced. Unfortunately, due to the meagre number of diagnostic sherds in the Bulebel sample only 28% of the amphorae sherds could be identified. The remaining 72% belonged to undiagnostic wall sherds. To extract some use from the

from the Melita Esplanade.

<sup>2</sup> This method worked well for the Bulebel and Foreman Street material as all the material from each context could be accessed and viewed relatively easily. This was not always possible for the material

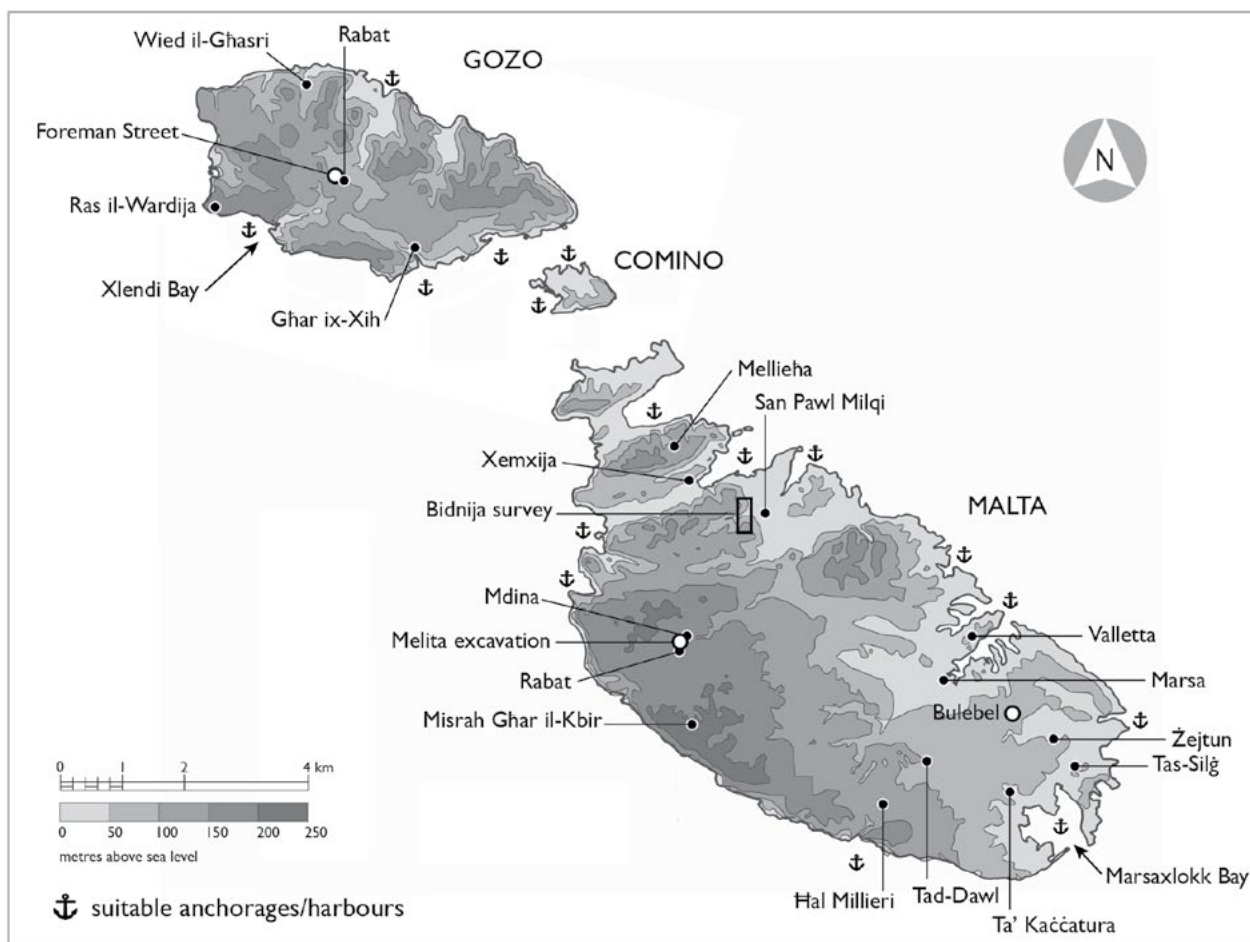

Figure 1: Location map of Malta and sites mentioned in text.

remaining 72% of the amphorae assemblage, all the sherds (RBHS) were divided into groups on the basis of fabric (i.e. local, North African, Italian etc.). Diagnostic features such as rims are not essential here, allowing greater inclusion of the sherds in the wider assemblage. To investigate whether there was a difference between the provenancing of the RBH and walls, and whether the total of the two reflected any different trajectories, the three different totals (1. RBH, 2. walls only, 3. Total RBHS) were plotted in a line chart (see **Figure 12**, bottom). Usually such charts are used to illustrate trends over time, but in this instance they will be used to reveal any significant divergences between the three different totals within each provenance group. This should allow any provenance trends not identified when looking at the diagnostic sherds (RBH) to be revealed by adding the total number of walls known to belong to the same group. For instance, the local sherds in the Bulebel Phase 1 assemblage (see **Figure 12**) are made up of 11 diagnostic fragments and 47 walls, which through visual examination are likely to belong to individual vessels. When each total is plotted against the other it is evident that by excluding the walls, the percentage of total local amphorae vessels drops quite significantly, potentially altering the final

conclusion. By adopting this combination of methods, the effect of residual sherds within the sample could be controlled to a certain extent. By identifying the types that chronologically are residual fragments in the assemblage, care could be taken when interpreting the totals of the remaining provenanced wall sherds which share similar fabrics to later vessel types.

The small sample sizes also conditioned the manner in which the remaining pottery classes were quantified. cooking wares were divided according to fabric (i.e. local, Italian, North African etc.), whilst fine wares were divided according to their known production class (i.e. local red-slip, Italian *terra sigillata*, African Red slip ware etc.). A combination of the two methods was adopted for amphorae.

### Chronology

The pottery data from the three sites were used to trace the import trends spanning the Late Republican/Early Imperial period through to the mid-fourth century (**Table 1**). Where available, comparisons were made with other published local material. The markedly different contexts (production site, rural dump and

Chronology	Site
4th-1st centuries BC	Residual fragments from all the sites
Mid-/end 1st century AD	Bulebel, phases 1-2; Melita, phase 1
First half of 2nd century AD	Melita, phase 2
End of the 2nd/mid-3rd century AD	Foreman Street; Bulebel, tomb-use phase
Mid-3rd – mid-4th century AD	Melita, phases 3-5

Table 1: The chronological divisions of assemblages used for the analysis in this study.

urban domestic context) presented challenges when comparing the assemblages against each other, and risked giving inconsistent results. Therefore, as much as possible, the quantified data from each phase within a site was taken to represent a ‘slice’ of the time period under study. The trends observed within these chronological periods are presented below.

**Classification criteria**

All the pottery was divided into one of four general classes of pottery: amphorae, cooking wares, fine wares and coarse wares. Local pottery forms almost always made up the entirety of coarse wares so this class was not included in tracing import trends. Instead, the vessels in this class were catalogued and studied separately to understand local pottery production and its chronological and spatial development across the islands. The remaining classes represent the types of pots that are known to have been extensively exported and imported across all regions of the Mediterranean. Because of this extra-regional export phenomenon, amphorae, fine wares and cooking wares are a very insightful proxy for gauging production, organisation and market demand for various products during the Roman period (see Wilson 2012: 229-244 and references therein). In addition, each class represents a different part of regional production and market demand because of the functions associated with each class. Amphorae are first and foremost containers for the storage and transport of the product they were made to carry. Thus, by studying amphorae we are in fact looking at the distribution of what they contained (i.e. olive oil, wine, fish sauce, dried fruit, alum etc.). The jar itself was of secondary importance and fortunately for archaeologists was often disposed of soon after it was emptied.<sup>3</sup> Fine wares and cooking wares were produced and exported because of their functionality – primarily cooking, eating and drinking – thus the demand and distribution plotted for these objects is different to that of amphorae. By looking at the different proportions of imported and locally produced vessels within each of

these classes, and viewing these patterns alongside each other we can potentially observe the mechanisms that enabled or hindered the various choices of imported items over time and what effects this might have had on local production.

<sup>3</sup> There are instances, however, where amphorae were reused. The mid-second-century Grado wreck carried a cargo of fish products packed in reused amphorae which were usually used to transport olive oil or wine (Auriemma 2000).



## The sites and their assemblages

The final reports on the contexts of the assemblages have yet to be published, therefore it was deemed pertinent to include details about the archaeological contexts in order to support the conclusions drawn for the pottery. It is with the kind collaboration of Nathaniel Cutajar (former Deputy Superintendent of Cultural Heritage Malta) and David Cardona (Senior Curator at Heritage Malta) that important stratigraphic information from the three sites studied is described below. Unfortunately, not all the stratigraphic information for all the sites was available, and as a result some site descriptions are more detailed than others.

A description of the sites is followed by a breakdown of their respective ceramic assemblages. This will highlight the main findings from each assemblage, and illustrate the main chronological phases apparent for the site's activities. Where possible, the analysis of the pottery worked in tandem with the phasing of the sites' stratigraphy and main activities. My own observations of the pottery together with the stratigraphic data made available to me are what formed the basis of the chronological associations presented below. These observations provided the primary dating evidence for the forms presented in the catalogue.

### **Bulebel, Malta (compiled together with N. Cutajar)**

In March 2012, a series of rock-hewn features was uncovered following the monitoring of the development of the former Actavis Malta factory within the Bulebel industrial zone (BLB2012), in the south-east of Malta (**Figures 1-2**). Archaeological excavations were carried out by the Superintendent of Cultural Heritage, Malta (SCH) and revealed three disused quarries filled in with rubble and construction debris (Pace *et al.* 2012). Cut into the side of the largest quadrangular quarry feature (Quarry 1[Q1]) were four tombs (**Figure 2**). The bulk of the material presented here comes from undisturbed stratified deposits, which filled Quarry 1 (**Figure 3**). About two-thirds of the quarry deposits were excavated stratigraphically and revealed a sequence of secondary dumping activity dating to between the mid- to end of the first century to the early third century AD. The pottery associated with the use of the tombs has been dated to the mid-third century AD. There was no evidence of an earlier use of the tombs.

A study of the ceramic material aided in the interpretation of the phasing of the site and indicates at least four distinct phases or activities. The first phase is associated with the quarrying of a large quadrangular

hole in the soft Globigerina Limestone bedrock. The second phase is associated with the accumulation of rubble and construction debris following the abandonment of the quarry. The material associated with this phase has been dated to the mid-end of the first century AD. From an assessment of the joining fragments it is also suggested that the stratigraphy was formed after several deposits were dumped in relatively quick succession, probably originating from the same source 'dump' located within the vicinity. A third phase was identified relating to a second dumping activity. A detailed look at the composition of the pottery from the contexts associated with this phase highlighted that the main range of forms that made up the deposits were near identical to the Phase 2 deposits, however, a handful of sherds could be securely dated to the mid-second/early third century AD. This may be interpreted as a further attempt at levelling out the deep quarry in preparation for the cutting of four tombs (Phase 4) within the quarry walls; or that the top layers were partially disturbed whilst the tomb quarrying was taking place. The imported pottery associated with the earliest interment (Chamber C, Tomb 3) dates to the early-mid/third century AD. This may explain the presence of 'intrusive' cooking ware fragments (Hayes 23B), which are several centuries later in date than the consistent first-century-AD pottery that makes up the majority of the latest dumping activity.

### ***The pottery assemblage from Bulebel***

The amphorae provided the best means of establishing a chronology for the Bulebel quarry assemblage. Just under 13% of the entire assemblage was composed of amphorae: of these, 74% are imported and 26% are local (**Table 2**). The amphorae types identified range from the Middle Punic period (c. mid-fourth/third century BC) to the beginning of the third century AD (**Table 3**).

Eighty-six out of 309 sherds were diagnostic enough to allow some sort of identification. The majority of the forms are Late Republican wine amphorae (Dressel 1, Lamboglia 2, Dressel 2-4), most of which originate from Italy (Campania and the Adriatic coast) based on the fabrics identified. The second most common form recognised is the Malta Type 1 amphora, identified and dated by Bruno to the Late Republican period (Bruno 2009: 101-105).

The only other Maltese amphora type is the Punic egg-shaped amphora. This is the typical transport container of the Punic period but is known in contexts dating to the mid-first century AD (Sagona 2002: 92-93). Imperial-

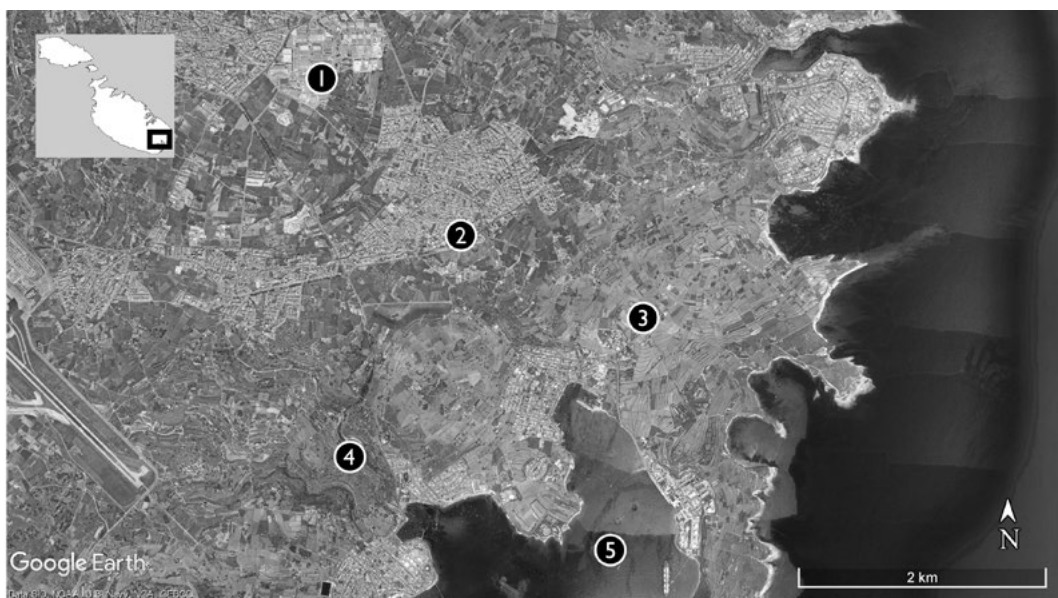

1) Bulebel site; 2) Zejtun villa site; 3) Tas-Silg site; 4) Ta' Kaccatura villa site; 5) Marsaxlokk Bay

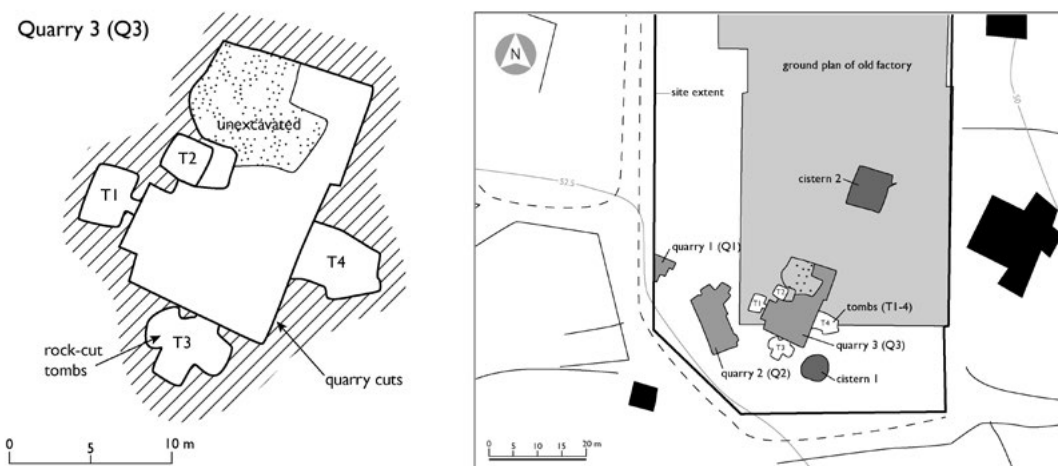

Figure 2: (top) Aerial view of south-east Malta indicating the location of the Bulebel site and other sites in the area (source: Google Earth); (bottom) Plan of the Bulebel quarry site (adapted from Pace *et al.* 2012, fig. 6).

period amphorae forms belong to flat-bottomed Mid-Roman 1b (MRA1b) amphorae of Sicilian production (most probably from workshops in Catania and Naxos) and have been dated to between the mid-first and mid-second century AD.<sup>4</sup> Single examples of Riley’s Early Roman Amphora (ERA) types 12 and 13 and a Crétoise 4 (Dressel 43) were also identified. No Imperial amphora forms were identified in the stratigraphically earliest phase (Phase 1). This, coupled with a high density of Republican forms and no later-dated imports within this phase, does indicate that Phase 1 is chronologically distinctive from the stratigraphically later phase (Phase 2).

cooking wares make up 14.6% of the total quarry assemblage; 8% are imports and 92% are local (Table 2).

<sup>4</sup> I wish to thank Dr Carmela Franco for confirming the identification of the Sicilian fabrics and providing clearer dates.

Handmade wares make up the bulk of locally produced cooking wares. The most common imported cooking ware fabric is Campanian (26.03%), identified because of the black sand and micaceous inclusions in the fabric. Minor quantities of Pantellerian (5.48%), North Tunisian (4.11%) and an unidentified import (1.37%) make up the remainder of the imported forms. The principal Campanian forms date to between the first century BC and early-to-mid first century AD. The Pantellerian sherds – only one of which is diagnostic – and the North African examples can be dated to the Imperial period. A Hayes 23B (C31.1-2) casserole dates from the mid-second to early third century (Hayes 1972: 45-48). The majority of the cooking ware category is dominated by local forms, the most typical form being Quercia’s olla type A1 (C1), which he dates to between the fourth and second century BC at the sanctuary of Tas-Silg (Quercia 2004-2005: 407), but which is known

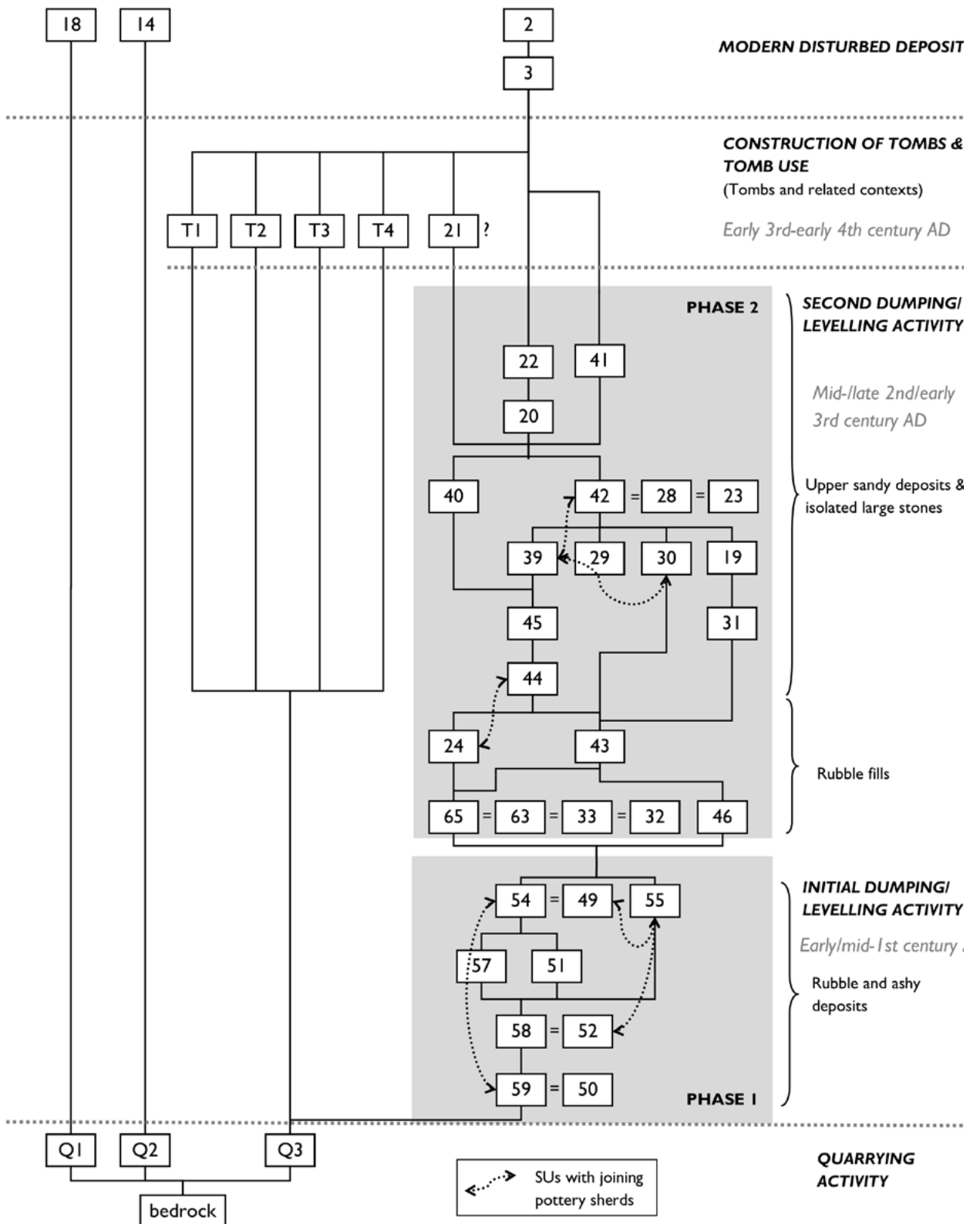

Figure 3: Stratigraphic matrix for the Bulebel excavation.

Type	Import		Local		Total		Proportion of import/local within each class	
	No.	%	No.	%	No.	%	Import (%)	Local (%)
Amphora	229	9.51	80	3.32	309	12.83	74.11	25.89
Cooking ware	28	1.16	326	13.54	354	14.7	7.91	92.09
Fine ware	21	0.87	58	2.41	79	3.28	26.58	73.42
Coarse ware	30	1.25	1636	67.94	1666	69.19	1.8	98.2
<b>Total</b>	<b>308</b>	<b>12.79</b>	<b>2100</b>	<b>87.21</b>	<b>2408</b>	<b>100</b>	-	-

Table 2: Number and percentage (RBHS) of imported and local pottery; and the proportion of imported versus local pottery from the Q3 assemblage at Bulebel (n=2408).

Amphora type	Provenance	Content/s	Date	No.	%
Punic egg-shape	Malta	Oil, wine?	4th c. BC - 1st c. AD	6	1.9
Greco-Italic	Campania (S. Italy)	Wine	3rd – mid-2nd c. BC	5	1.6
Van de Werff 1	N. Tunisia (N. Africa)	Garum?	2nd – 1st c. BC	1	0.3
Dressel 1	Campania & Adriatic (S. Italy)	Wine, seashells, resin, hazelnuts, garum, olives	mid-2nd – end of 1st c. BC	17	5.5
Lamboglia 2	Adriatic (S. Italy)	Wine, olive oil(?)	2nd – end of 1st c. BC	7	2.3
Malta type 1	Malta	Oil, fish sauce	End 2nd – end 1st c. BC	13	4.2
Unknown*	N. Africa	-	-	2	0.6
Unknown*	?	-	-	11	3.6
Dressel 2-4	Campania & Adriatic (S. Italy)	Wine; Falerian(?) - 'praised vintage'	Mid-1st c. BC – end of 1st c. AD	10	3.2
ERA12	?	?	Mid-/end 1st c. AD	1	0.3
ERA13	Naxos (Sicily)	Wine?	1st c. AD	1	0.3
MRA1b	Catania (Sicily)	Wine?	Mid-1st – mid-2nd c. AD	7	2.3
Crétoise 4/Dr. 43	Crete	Wine, preserved fruit	Early 1st – early 3rd c. AD	1	0.3
Unknown*	N. Africa	-	-	4	1.3
Unknown**	Malta	-	-	61	19.7
Unknown**	Adriatic	-	-	40	12.9
Unknown**	N. Africa	-	-	29	9.4
Unknown**	Campanian	-	-	19	6.1
Unknown**	Sicilian	-	-	24	7.8
Unknown**	Spanish	-	-	3	1
Unknown**	Eastern	-	-	1	0.3
Unknown**	Import	-	-	46	14.9
<b>Total</b>				<b>309</b>	<b>100</b>
* unknown diagnostic (RBH) sherds ** unknown undiagnostic sherds					

Table 3: Amphorae types from Bulebel.

from tomb contexts dating to at least the mid-first century AD (Sagona 2002: 222).

Very few fine ware fragments were identified in the quarry assemblage (1.49%; **Table 2**). Of these, 58.33% are local red-slipped fragments, and the rest are imported

(41.67%). The imported fine wares consist of residual Hellenistic black-slipped pottery (27.78%), Eastern red slip (8.33%) and Italian terra sigillata (5.56%). A series of locally produced thin-walled ware bowls make up 1.79% of the assemblage, most of them made in local fabrics. A handful of imported Italian and possible North African

examples have been recorded too, including one well-preserved profile of a Knidian Grey ware cup (**B28.1**) datable to the Early Roman period (Hayes 2008: 269). The absence of African Red slip ware suggests that the assemblage is composed of pottery that was deposited no later than the mid-first century AD.

### **Foreman Street, Rabat, Gozo (compiled together with N. Cutajar)**

In 2008, rescue excavations directed by the SCH, were conducted in Foreman Street (FRM2008) in preparation for the development of private housing west of the historic city of Cittadella, Rabat, in Gozo (**Figures 1 and 4a**). Excavation revealed a series of deposits composed of ash and pottery. No kiln structures were identified, however the composition of the stratigraphy, with its ash, multitude of pottery, and ceramic wasters is indicative that the site may have been the dumping area for a nearby pottery workshop.

This assemblage was chosen for study as it provides a unique opportunity to study local pottery production on the island of Gozo. To date, no known ceramic production areas are known archaeologically on the island. On Malta, no well excavated production sites are known either, although recent excavations at a site in Żebbiegħ (ZBH2006), in the north of Malta, brought to light a disused cistern or large pit filled with ash mixed with pottery dated to 600-200 BC, very similar in composition to the site at Foreman Street (see below).

Material from three stratigraphic units (42, 57 and 59), totalling 3621 sherds, was chosen for analysis as a general overview of the material showed that the make-up of the ceramic material was relatively homogenous. These three contexts were contemporary and make up about 30% of the total deposits excavated. Due to time limitations, and being secure in the knowledge that these three contexts were representative of the standardised material at Foreman Street, only a portion of the entire assemblage was studied.

### ***The pottery assemblage from Foreman Street, Gozo***

coarse wares make up over 90% of the assemblage at Foreman Street. Sixty-five per cent of these can be attributed to one of at least nine types of pottery vessels that can be securely tied to the Foreman Street repertoire (**Figure 4b**). The frequency and multitude of wasters belonging to these types strongly suggest that they were produced within the vicinity. The shape repertoire is made up of bowls (types **D9-D12**, **D14**), plates (type **D15**), large bowls (types **D39-D40**) and jars (types **D60-D62** and **D64**). All these forms are made in a glauconitic fabric (Local fabric 2), which is similar in general composition to the glauconitic fabric recorded in the Bulebel assemblage (see below). A local

clay source for the production site is possibly the area around Il-Gelmus hill, located opposite the site, and which has one of the few outcrops of Greensands above a clay bed on the islands (**Figure 1**). The distribution of these vessels so far appears to be restricted to the island of Gozo and due to the lack of published excavations of the Roman period, no parallels for these vessels can be recognised, aside from those from a single tomb context in Wied il-Ghasri (Sagona 2002: 1124-1126).<sup>5</sup> Earlier variants of some of these forms, in a different fabric associated with the Punic period, are known from Late Punic sites such as Għar ix-Xiħ (Quercia and Anastasi 2008-2009) and a sanctuary site at Ras il-Wardija, Gozo (Cagiano de Azevedo *et al.* 1965, fig. 14.9).

Only four diagnostic amphorae sherds were identified in the assemblage. Three are North African and one is local. One of the North African rims is damaged, making it difficult to make a confident identification, although it may belong to the Africana II series on the basis of the fabric (see Bonifay 2004, figs 57-59). No parallels for the remaining two African rims can be found, but they are similar to some of the Mid-Roman jugs identified by Riley in the material from Berenice (Riley 1979: 139.1157). The single local example shares similarities with the Malta type 2 series with a glauconitic fabric with traces of volcanic augite, which is the rarer variant identified by Bruno for the Maltese islands (Bruno 2009: 105, fig. 18.1).

When the amphorae wall sherds are taken into consideration, the overall picture of the amphorae at the site changes, even though amphorae only make up 2.73% of the entire assemblage. The fabrics indicate that the majority of amphorae have a North African origin, all of which can be sourced to North Tunisia (on the basis of Peacock's 2.1 and 2.2 fabrics) or Central Tunisia (Peacock 2.6) at 46% and 21% respectively (Peacock 1984a: 14-18). Two fine buff fabrics, one of which contains added micaceous inclusions, accounted for 23% of the assemblage. No diagnostic sherds were associated with this fabric so a detailed identification of the forms and provenance of this fabric is not possible. The fabric may, however, originate from the Adriatic or Aegean area when compared with fabrics from Bulebel. Five per cent (5%) of the wall sherds share affinities with the Agora F65-66 fabric typical of the coastal areas of Asia Minor and belong to the Agora F65-66 amphora or its successor, the Late Roman Amphora 3 (LRA3).<sup>6</sup> The Agora F65-66 form has a long date range from the mid-first century BC to the fourth century AD. Finally, only 1% of the amphorae fabrics can be ascribed to a local

<sup>5</sup> The objects from this tomb are currently on display at the National Museum of Archaeology in Rabat, Gozo.

<sup>6</sup> See Keay and Williams 2005 for the fabric description on: [http://archaeologydataservice.ac.uk/archives/view/amphora\\_ahrb\\_2005/details.cfm?id=311](http://archaeologydataservice.ac.uk/archives/view/amphora_ahrb_2005/details.cfm?id=311) (seen on 24/05/2013).

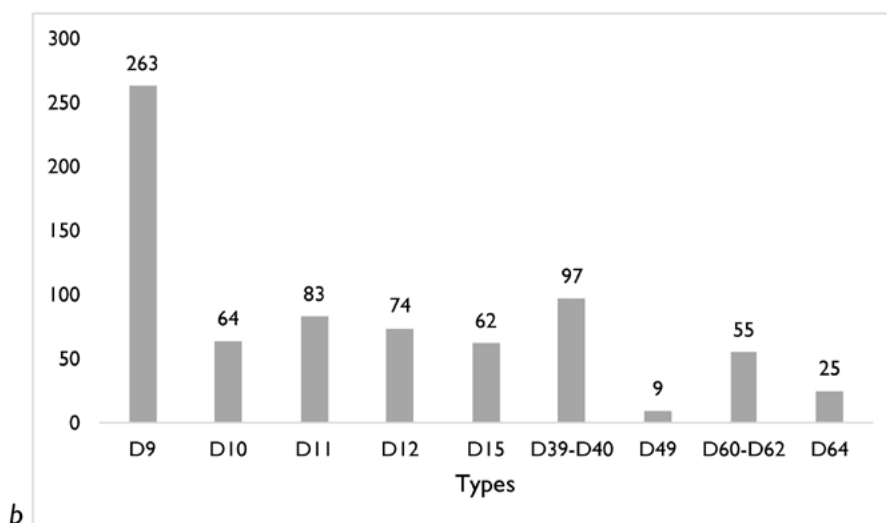
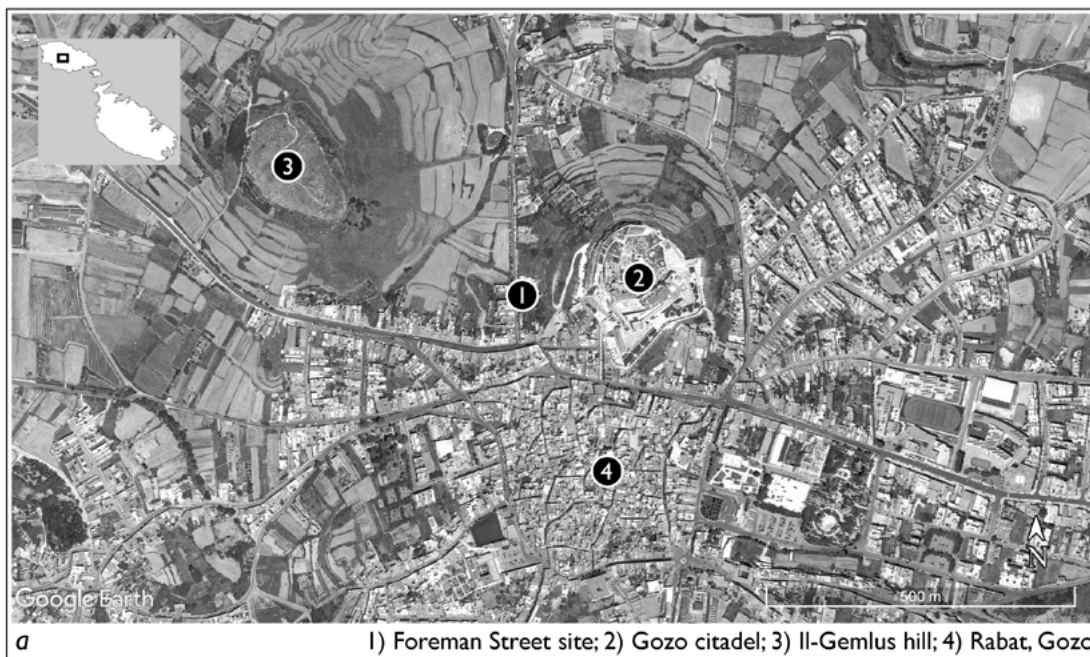

Figure 4: a) Aerial view of Rabat, Gozo, indicating the location of the Foreman Street site and key surrounding sites (source: Google Earth); b) Number (RBH) of predominant local coarse ware types identified at Foreman Street (n=732).

source, eliminating all possibility of local amphorae production at the site.

cooking wares made up the second largest class in the assemblage (3.89%) and are composed entirely of imported North African (62.75%), Pantellerian (33.33%) and Southern Italian (3.92%) vessels. No local wheelmade cooking vessels were recorded. Instead, only a tiny proportion of handmade vessels (0.3%) were counted (Table 4).

The predominant North Tunisian cooking ware forms are Hayes 197 casseroles (17.14%) with their respective lids, Hayes 196 (10%), which date to between the second and fourth century (Bonifay 2004: 225). They are also

associated with variants of casserole forms Hayes 23A and B (2.86%), which were produced in the same area and are generally contemporary. The lid form Hayes 185 makes up 5.71% and is also a North Tunisian production dating to the end of the second to mid-third century (Bonifay 2004: 221). Less common forms include several lid (Hayes form 182, Fulford forms 11.5 and 14) and casserole forms (Hayes 183, 193 and Riley’s MRCW1c). The latter form appears to match the ‘Benghazi local fabric 4’ classified by Riley for the assemblage from Berenice, suggesting that this typically Italian form may be a Cyrenaican imitation (Riley 1979: 261). Riley dated the form from the first and second centuries, although he noticed the frequency peaked during the early third century at Berenice (Riley 1979: 259).

Type	Import		Local		Total		Proportion of import/ local within each class	
	No.	%	No.	%	No.	%	Import (%)	Local (%)
Amphora	99	2.73	1	0.03	100	2.76	99	1
Cooking ware	130	3.59	11	0.30	141	3.89	92.2	7.8
Fine ware	38	1.05	47	1.30	85	2.35	44.71	55.29
Coarse ware	26	0.72	3269	90.28	3295	91	0.79	99.21
<b>Total</b>	293	8.09	3328	91.91	3621	100	-	-

Table 4: Number and percentage (RBHS) of imported and local pottery; and the proportion of imported versus local pottery from Foreman Street (n=3621).

A third of the cooking wares are Pantellerian in origin and are represented by a series of recurring forms. Attributing dates to Pantellerian ware forms can be problematic because of the longevity of a standardised repertoire, which changed little from the first century to the fifth century. Five forms were recognised in the assemblage, the most common form being a shallow pan with a slightly flaring triangular rim (**C46**). This form has a long life and has been recorded in various contexts dating to between the first century BC and fifth century AD (Fulford 1984: 157). The Foreman Street examples share more similarities with the third-century examples from Cosa (Dyson 1976: 139-140, fig. 59: LS52-53), where both examples displayed a more pronounced and pointed triangular rim than the later almond-rim-shaped vessels from well-dated fifth-century contexts in Carthage and Pantelleria (Baldassari 2009, tav. II). This observation may be compounded by the conspicuous absence of any of the olla forms (in particular type **C44**) in the later-dated Carthage material, coupled with the absence of any of Fulford's forms 2 and 3 and Quercia's tegame tipo 1 and 2 from the Foreman Street assemblage, the latter being most common in the sixth- and seventh-century contexts at Tas-Silġ (Quercia 2006, fig. 8).<sup>7</sup> Quercia's study of Pantellerian ware from the sanctuary of Tas-Silġ showed that forms **C44** and **C46** were most numerous in contexts dating to the third-fourth centuries (Quercia 2006: 1608). No parallels have yet been found for the casserole type **C45** and these are also absent from the Carthage contexts (Fulford 1984).

Only two wall fragments of Southern Italian cooking ware (characterised by a gritty brown micaceous fabric) were recovered from the Foreman Street assemblage. The absence of any distinguishing forms makes it difficult to draw any further conclusions.

<sup>7</sup> Pantellerian ware forms associated with later-dated contexts at Sabratha (types 303-307) are also absent from Foreman Street, whereas forms (types 291 and 293), that have been dated to the second century AD are very common at Foreman Street (Dore 1989: 216).

Just over 2% of the assemblage was made up of fine wares. Of these, 45% are imports and 55% belong to local red-slipped pottery (**Table 4**).

Although ARS accounts for the majority of imported fine wares (28%), only one ARS rim that belongs to a Hayes 6 bowl (**B40.2**) can be identified and is generally dated to between the end of the first and the end of the second century (Hayes 1972: 29-31, fig. 3).<sup>8</sup> The fabric appears to be typical of the ARS A Northern Tunisian production. Another ARS C ring base of a bowl (**B41.4**) with a shoulder carination was also recovered but no direct parallel can be found for the form. The ARS C fabric was the predominant fabric identified.

The second most common imported fine wares are Corinthian Roman relief ware bowls (**B39**). These small mould-made bowls are typical of Corinthian workshops in the third century (Hayes 2008: 111). Parallels for these bowls can be found in Corinth (Canaday Spitzer 1942) and in the Athenian agora and date to the third century, as well as several other sites in the central Mediterranean (Hayes 2008: 111, fig. 54: 1686-1711; see Malfitana 2005; 2007).

Local fine wares are entirely made up of hastily coated red slipped pottery (55.23%), here considered the typical local fine ware of the Roman period. The most common red-slipped bowl forms have flaring or flat rims (types **B5** and **B6** respectively). A couple of examples of red-slipped bowls appear to be local imitations of African Red Slip ware bowls, in particular Hayes 6, which have flat-topped everted rims, incised with a groove. The local red slip vessels are made using the generic glauconitic fabric (Local fabric 2), however, the fabric tends to be much softer, and in many instances, paler, than the unslipped examples. A thin, uneven, dull to bright red, matt slip coats the surface

<sup>8</sup> This sherd is most probably residual as the fragment is small and very worn when compared with the remaining sherds in the assemblage, which all have fresh breaks.

although the black glauconite inclusions are still visible on the surface. Local red slip pottery is known on Malta (Sagona 2002: 84), but no production centres have yet been identified. The characteristic glauconitic fabric and the vessel forms identified at Foreman Street strongly suggest that both red slipped and unslipped versions of the same form were produced at the site. The few examples of imitation Hayes 6 suggest the possible experimentation on the part of the potters to replicate imported forms. Incidentally, an example of a North Tunisian Hayes 6 bowl rim was also recovered from the same deposit and may have acted as the models which the local potters adopted to copy the form. None of the Hayes 6 imitation red slip vessels have unslipped counterparts like the type B5 bowls.

A few fragments of imported thin-walled cups were also identified (7.06%). Only two rim fragments were diagnostic enough to allow identification, and belong to one-handed cups or mugs (B32.1-2) commonly found in Maltese Late Punic/Roman tombs (Sagona 2002: 191-192, fig. 349: 49). The fabric for the illustrated examples is fine, granular and dark grey in colour with lots of fine quartz, and occasional fine white inclusions. The form is a very common one and is characterised by a thin everted rim which has a small raised band (Marabini form LXVIII) at the junction between the rim and the start of the shoulder. This shape is mainly common in Italian (such as Cosa; see Marabini Moevs 1973: 237, pl. 46) and Adriatic contexts, as well as the western Mediterranean, however, similar vessels are known in the Athenian Agora (Hayes 2008: 101-103, fig. 51), and have been dated from the Flavian period up until the second century.

#### **Melita Esplanade, Rabat, Malta (compiled together with D. Cardona)**

Between 1983 and 1984 a small trial trench was excavated in an area known as the Melita Esplanade, close to the Roman domus in Rabat, the location of the ancient Maltese capital (Figures 1 and 11). The excavation was a test project led by E. Elster and her team (which included J. Lander as field supervisor, and M. Molitor as finds supervisor) from the Institute of Archaeology at the University of California, Los Angeles (UCLA), in collaboration with the National Museum of Archaeology in Malta. The trial trench was opened in expectation of plans to carry out a larger-scale excavation within the Mdina area. However, relations between the American team and local authorities soured during the 1984 season, and the collaborative project was abandoned shortly after (Sausmekat 2016: 66-73).

The two short seasons revealed parts of orthogonal ashlar structures either side of a linear road or street (Figure 5). Investigation of the eastern structure (Structure A) revealed a clear series of floor levels, after which the

structure was abandoned, fell into disrepair and was buried under accumulated debris. The stratigraphy of the site revealed at least seven activities, a few of which are thought to be contemporaneous events (see below). The earliest levels reached are associated with the construction of a series of floors laid out in the early first century AD. A near-complete 'Arretine plate' was associated with the preparatory layer of the earliest floor of the structure, however, this vessel was not traced during the study of the material in 2013, therefore we have to rely on the date and description provided by the excavators (Lander 1983: 3). Only a few fragments of diagnostic pottery were recovered from the succeeding floor preparatory layers, which date to no later than the end of the first century AD, and provide a *terminus ante quem* for the construction of the ashlar structure (A).

No distinct occupation layers were noticed within the structure, but a large deposit made up of rubble appears to be chronologically distinct from the latest Roman-period activities which took place after the former's deposition. This can be dated to around the early to mid-second century AD. Three other levelling/depositional events associated with the abandonment of both structures (A and B) date to the Late Roman period. Phases 3 to 5 have been dated to no later than the mid-fourth century. A total of 14 coins was found during both seasons, and according to Lander, none of the coins post-dated the second half of the fourth century AD (1984: 6).

The remainder of this section is an exercise in reconstructing the stratigraphic sequence of this small excavation. No context sheets from the excavation were found, but two somewhat detailed (unpublished) preliminary reports (Lander 1983; 1984) and trench notebooks (Cilia 1984; M. Zammit 1984; V. Zammit 1984) were available, which allowed the stratigraphy to be reconstructed. Although not explicitly stated, the descriptions of the excavated deposits and annotated notebook sketches and plans strongly suggest that the excavation was carried out in a stratigraphic manner, and each deposit and feature was assigned a unique number and added to the notebook entries. Forty-two boxes of pottery and other artefacts were located in the stores of the National Museum of Archaeology in Valletta (Malta), and many of these were clearly labelled with the respective SU numbers. Some details were not clear, and there are omissions of Stratigraphic Units (SU) that either had no pottery or that contained modern disturbed material. From a detailed reading of the preliminary reports, it is clear that no distinction was made between the cuts and their subsequent fills, which made it difficult to identify the contexts on the available sketch plans. Where necessary, cut numbers (C1 and C2) were assigned within the



Figure 5: Plan of the Melita Esplanade trench showing the structures discovered (after Lander 1984, site plan).

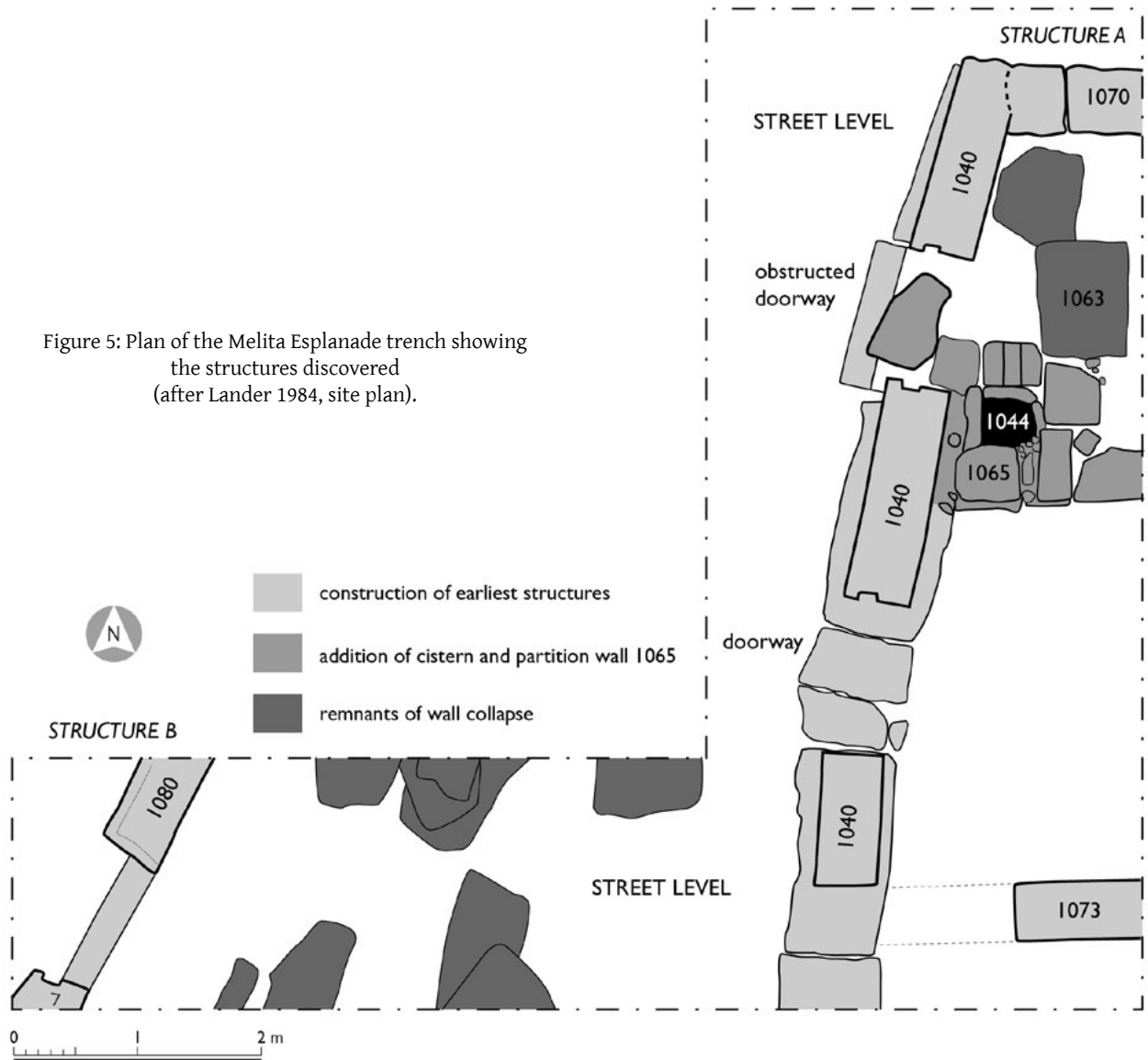

stratigraphic description of the layers. Indeed, none of the original scaled plan and section drawings were available, as their whereabouts are unknown to us. In spite of this, a Harris Matrix of the stratigraphic sequence was generated using the available unpublished preliminary reports and the plan and section drawings presented within them (Figure 6). The next section describes the phased stratigraphic evidence generated by the Harris Matrix, and dated by the pottery assemblage.

### *Stratigraphic report for Melita Esplanade*

#### *Phase 1: Construction of street and adjacent buildings*

The earliest phase is linked to the construction of the only visible structures (A and B) either side of a hard, concrete-like street surface (1090). The largest structure (A) consists of a linear ashlar wall (1040),

running diagonally along a roughly north-south axis. The wall extends from the southern trench section for about 7.75 m, where it is joined by a return wall (1070) at an oblique angle, which runs for about 1 m before it goes into the east trench section. The wall survived to a level of three courses (c. 1.60 m high) and contained two doorways with wide stone thresholds, connecting the street to the interior of the structure (Figure 7).

Information regarding the foundation trenches for these walls is elusive in the site notebooks and preliminary reports, but Lander mentions that 'at the lowest level excavated [...] this level marks the bottom of a cutting which at first appeared to be a pit but which is now considered to be probably [sic] a construction trench (1112) for the west wall (1040) of Structure A' (1984: 3). Two more 'hard' and 'concrete-like' surfaces (1113 and 1114 respectively) are said to pre-date or be truncated by structure A (1040). Therefore, these

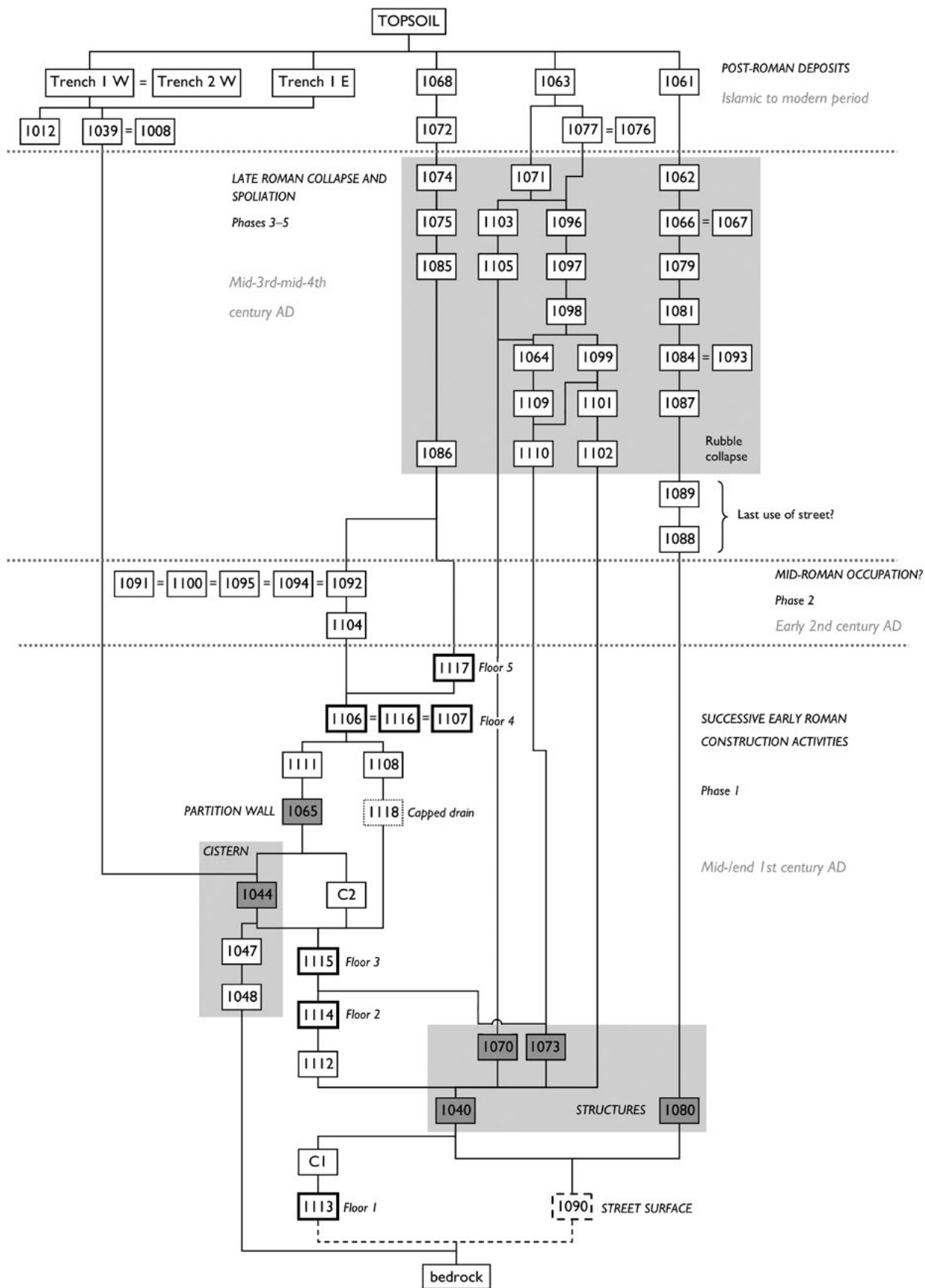

Figure 6: Stratigraphic matrix for the Melita Esplanade excavation.

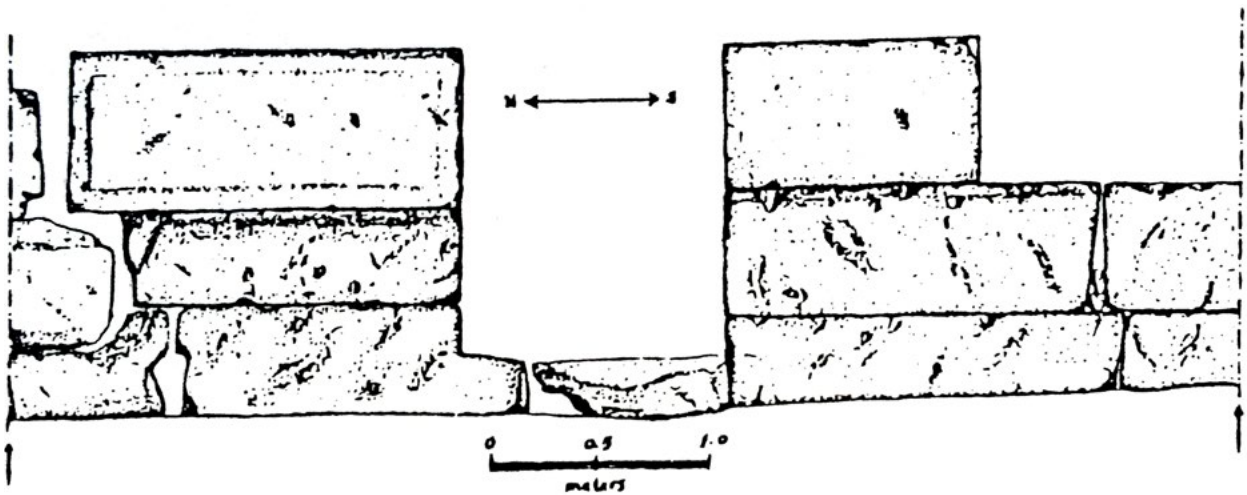

Figure 7: West-facing elevation of wall 1040 (Elster, Lander and Molitor 1984, fig. 5).

surfaces belonged to floors from an earlier structure. No pottery was found directly associated with these floors. The finds belonging to fill 1112 were not found when the study of the material was underway in August 2013, however, Lander mentions that ‘in the small area [1112] excavated (and on the last day of the excavation!) we found about one-third of a very fine Arretine serving-dish approximately 50 cm in diameter. Immediately above this deposit lay a coin (Number 9), which at the time of writing has not yet been cleaned well enough for a reading’ (Lander 1983: 3).<sup>9</sup>

From the data available the stratigraphy can be interpreted as follows (Figure 8): the earliest ‘floor’ belongs to a hard brown sloping layer 1113 thought to be part of the preparation layer for an overlying floor surface, probably 1114, described as a concrete surface at a height of 190.68–74 m above sea level, sloping from west to east (Lander 1984: 6).<sup>10</sup> However, from the available plan, it appears that prior to the laying of 1114, a linear trench (C1) running along a north-south axis was cut into the hard brown surface 1113 and can be linked to the construction trench for wall 1040. This trench was filled with a loose soil fill 1112 (filling C1).

A second (and stratigraphically later) pit (C2) appears to cut through floors 1114 and 1115, and is filled by a

<sup>9</sup> Lander 1984: 3. No additional information regarding the coins is known other than the cataloguing of three Maltese mints in a recent publication by Claudia Perassi (2013). Of these three coins published by Perassi, the context location of only one (no. 1 from the cistern context 1044) is listed. The other two catalogue entries do not contain contextual information, thus it is not clear which SU they were found in.

<sup>10</sup> Lander does mention in his last report that natural deposits (i.e. bedrock) were not reached beneath the interior archaeological layers. However, he calculated another 70 cm from the lowest excavated level to bedrock which was identified during exploration of the cistern (Lander 1984: 6).

loose soil fill 1111. What remains unclear is the exact relationship between wall 1040 and floor 1114. V. Zammit claims that the floor extends beneath both 1040 and 1065. The latter can clearly be seen in the west-facing section of Area 5 (1984: 33–34) (Figure 9), however no clear plans, sections or sketches feature the former. If this is the case, then it would not be stratigraphically possible for 1114 to underlie wall 1040, yet seal its foundation trench (cut C1 and fill 1112). Thus, exactly how wall 1040 relates to the earliest surfaces remains unclear.<sup>11</sup> It is also possible that surfaces 1113 and 1114 are not contemporary and do not belong to the same activity.

A later phase of building activity is linked to the cutting of a bell-shaped cistern (1044) and the addition of a second interior partition wall (1065) following the alignment of the stratigraphically earlier wall 1073. This wall extends eastwards from the ashlar wall 1040, towards the east section for about 2 m, and is constructed using smaller unworked limestone blocks. It is shown to lie directly over level 1114 and survives to a height of 1.60 m. Cut 2 (C2) may be the construction trench that cuts into floor surface 1115, for the new wall 1065, although the material associated with this supposed construction fill remains unclear, and may actually also be filled by 1111. A sketch showing the layers revealed once 1111 was excavated show 1114 and 1112, thus 1111 post-dates all of these and appears to be the construction fill for wall 1065.

The construction of a cistern (1044) resulted in the obstruction of an existing doorway. The exact association of the cistern and structure A remained

<sup>11</sup> Although unclear, Lander also seems uncertain about the earliest sequence of floor levels (Lander 1984: 3).

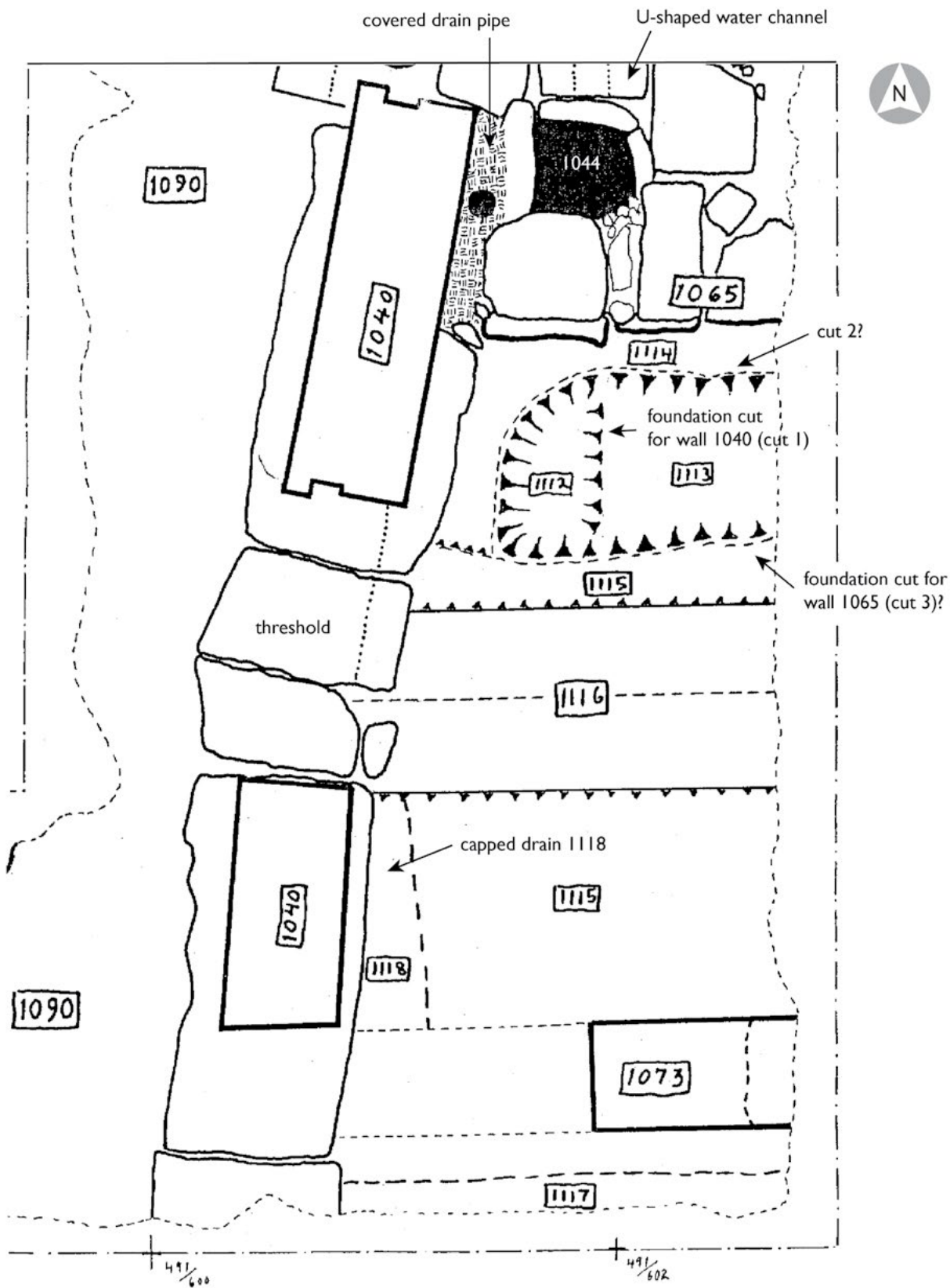

Figure 8: Detailed plan of interior floor levels within Structure A (after Lander 1984).

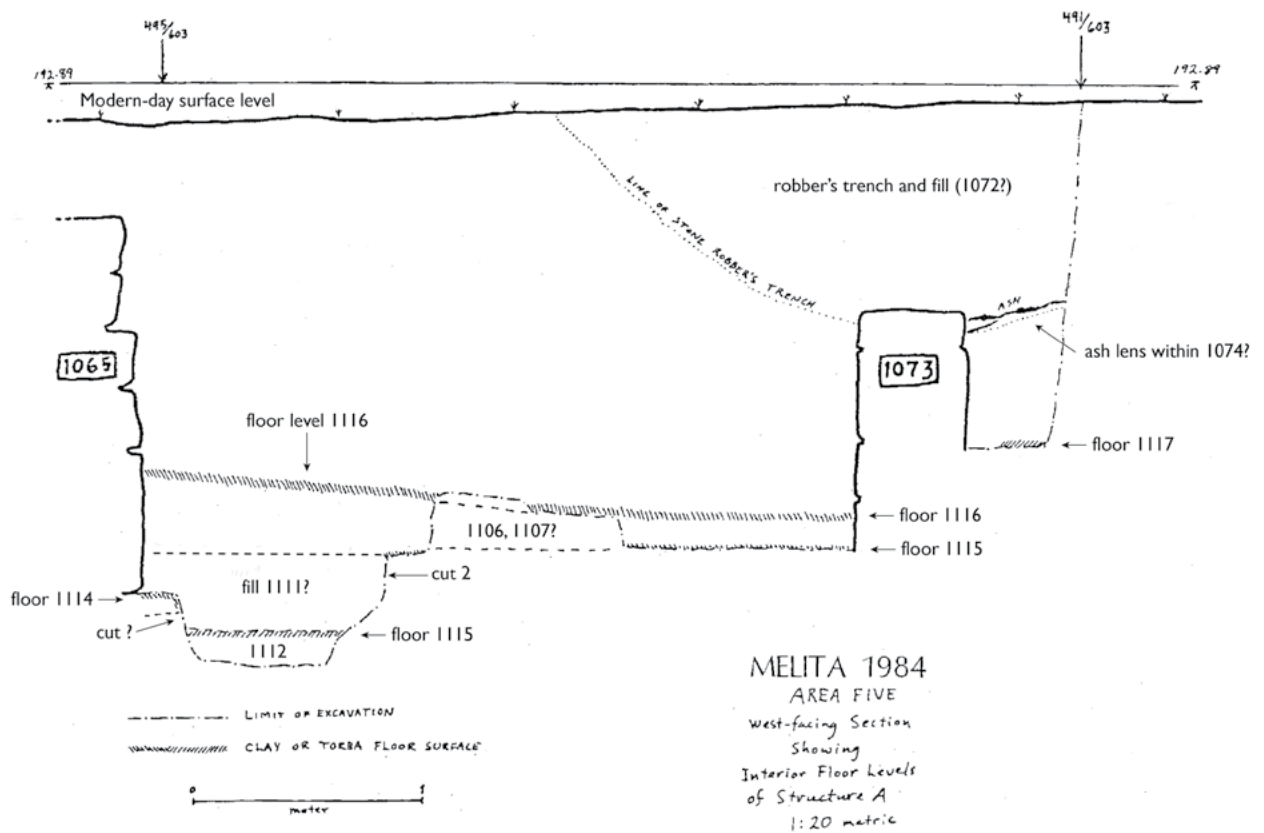

Figure 9: West-facing section drawing of interior of Structure A (after Lander 1984).

uncertain by the end of the 1984 season. However, it was clear that the construction of the cistern head certainly post-dated wall 1040, but was overlaid and incorporated into the second partition wall 1065, either pre-dating, or being contemporary with it (Lander 1984: 6). The main part of the cistern was hewn directly out of bedrock (the bedrock level reached was 189.74 m above sea level; **Figure 10**). Spot heights and further stratigraphic details pertaining to the excavation of the areas surrounding the cistern head and wall 1065 remain elusive. The interior of the cistern was lined with a waterproof plaster lining and contained at least two deposits (1047 and 1048), which filled the cistern. Due to time constraints, only a small sample of the pottery filling the cistern was analysed (1044) and it was not included in this study.<sup>12</sup> Nevertheless, the sample suggested that the pottery from the cistern fill (1044) was composed of local coarse ware jar/jug bases consistent with flagons similar to type **D57**. Very little diagnostic material was identified but no material consistent with the Late Roman spoliation appears to be associated with the cistern assemblage and may suggest that the cistern went out of use before the destruction

of the buildings themselves. The presence of coarse ware pottery made in Local Fabrics 2 and 3 suggests a post-first century date, whilst one coin provides a *terminus post quem* of the second century BC (Lander 1984: 5; Perassi 2013: 40, no.1). Careful attention was paid to the cistern's material during the excavation, including the sieving of all the material excavated. The excavators also believe that there were a few pots which could easily be reconstructed (Elster, Lander and Molitor 1984: 3). The scenario would then be consistent with coarse pottery jugs and jars that were lost whilst drawing water.

Clearer still is the laying of a fourth floor surface (1116) which is linked to two hard crusts with embedded pottery sherds (1106 and 1107). This surface sealed all the existing walls in structure A (1040, 1065 and 1073) and was raised to the level of the threshold block. A fifth floor surface (1117), only surviving south of the partition wall 1073, appears to be the latest floor surface within structure A. A capped drain placed within a linear trench cut into the earlier floor 1115, and running parallel to wall 1040, was filled with a loose rubble deposit 1108, before being covered and sealed by the fourth floor 1116. This drain is aligned with another

<sup>12</sup> It is the intention of the author (MA) to complete the pottery study of the cistern's contents in the near future.

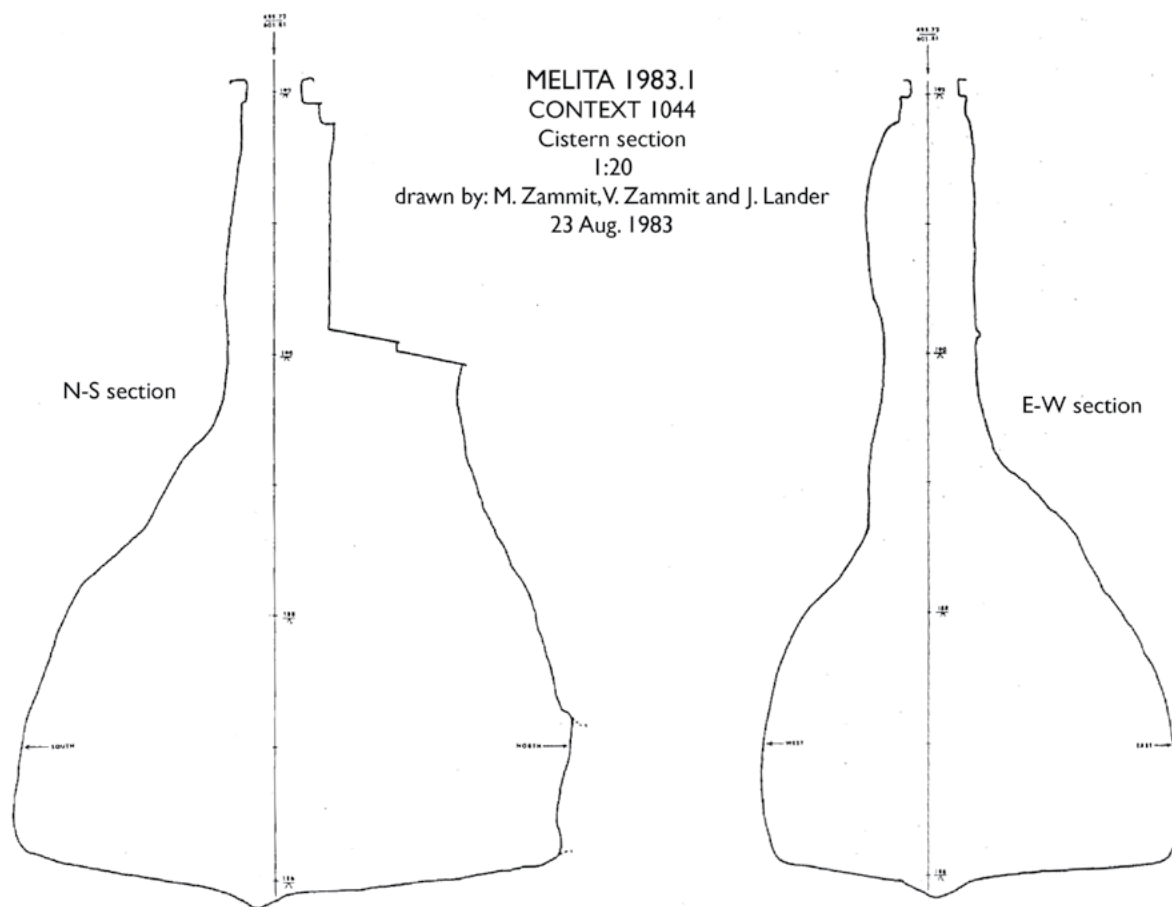

Figure 10: Section drawings of cistern 1044 (after Lander 1984, figs VI-V).

further north, and presumably drained water into the adjacent cistern (1044) (Lander 1983: 6).<sup>13</sup> A circular hole within the northern drain pipe was probably attached to a vertical pipe that directed water from the roof or a second storey. Another U-shaped block appears to have directed water collected from the northern part of the structure (Figure 8).

Very little of Structure B was exposed. A stone slab belonging to a threshold, in between two worked limestone ashlar blocks, one with a carved jamb niche, ran roughly parallel to structure A (Figure 5).

*Phase 2: Mid-Roman occupation?*

This phase defines the deposit that accumulated above (and after) the construction of the structures A and

B and subsequent floor levels in Phase 1. This large homogenous deposit was excavated in spits of 10-15 cm and was made up of loose soil with small rubble stones (1091, 1092, 1094, 1095, 1100 and 1104). These deposits were contained within the confines of structure A, and none of the material dates to later than the early to mid-second century AD. At least one bronze coin was found in SU 1086, however little information, other than that it could be a local issue, is available (V. Zammit 1984: 18).<sup>14</sup> That the building was already abandoned by this phase is suggested by the presence of architectural fragments such as a limestone cornice in one of the deposits (V. Zammit 1984: 17-18). This date is slightly later than that for the abandonment of the Roman domus located a short distance away, which is thought to have occurred sometime before the end of the first century (Bonanno 2005: 214).

<sup>13</sup> This part of trench 1 was excavated during the 1983 season where fewer stratigraphic details were recorded. The exact SU numbers and their stratigraphic relationships for the drain, cistern and wall 1065 are not clear. Nevertheless, the general sequence of events can be deduced.

<sup>14</sup> If the coin is a local Roman mint then this would date to after the second century BC (Bonanno 2005: 156-157).

### *Phases 3-5: Late Roman Spoliation*

This activity is clearly associated with the latest Roman-dated phase and possibly with the final abandonment, disuse and destruction of the structures, marked by the accumulation of rubble and large worked stone blocks, which are remnants of the collapse of the structure's walls (1064). The excavators commented on the fact that the position of the fallen blocks indicated that the structures, at least those belonging to Structure B, collapsed onto the street (1081). Associated with these collapse layers were plain and painted wall plaster fragments which probably formed part of the interior of one of the buildings. Also of interest is the discovery of many metal nails and several worked bone cylinders measuring about 30 mm. These finds were concentrated around the doorway of structure A (1080) and most probably belong to the remnants of bone door hinges, perhaps for cupboards (Allison 2004: 52). Only a few fragments of brick and roof tiles were identified, providing some evidence for the methods of construction, although far too few were recovered that could have covered an entire roof. In fact, roof tiles are not at all common on the islands and could point towards alternative methods for constructing roofs. A large fragment of *deffun* (a mixture of lime and crushed pottery traditionally used for sealing flat roofs on the island) was found in context 1079 attached to a large block of stone and may have come from a fragment of the ceiling. In addition to these, many more lozenge-shaped floor tiles made in fabrics similar to Local Fabric 1 and 3 were recovered from the collapse debris. These are one of the most common types of floor tiles found on Malta from the Early Imperial period, both in urban and rural settings.<sup>15</sup> It appears that the main collapse of the buildings fell more or less directly over a relatively clean street surface, which did not contain any other debris other than a few small worn sherds, some of which were embedded in the concreted surface (1087, 1088 and 1089).

The latest ceramic material has been dated to the early to mid-fourth century AD (see below) and is consistent with the preliminary dating of the majority of the 14 coins excavated and dated during the 1983-84 campaigns. The latest-dated coin belonged to Constantius II (337-361 AD), thus providing a useful *terminus post quem* for the last Roman phase prior to the post-Roman period. This latter phase is thought to be Islamic in date due to the green-glazed pottery found

<sup>15</sup> Discoveries of Roman-period floors paved with such tiles include Is-Saqqajja and the Roman domus in Rabat (Bonanno 2005: 168, 216); the Żejtun villa (Bonanno and Vella 2012: 13); the Ghajn Tuffieha baths and Ras ir-Raheb (Scott 1962: 2). A cardboard box containing material from the 1961-62 excavations at Ras ir-Raheb is filled with loose lozenge-shaped tiles, and most likely originate from the paved floors at the site. The box of tiles can be found at the National Museum of Archaeology, Valletta.

in the deposits (Lander 1984: 6-7).<sup>16</sup> Lander raised the possibility that the dating of the mid-fourth-century rubble and wall collapse could indicate that buildings located within the outskirts of Melita (modern-day Mdina) were already abandoned and in severe disrepair before the Byzantine and later Islamic period. The neighbouring Roman domus, which was excavated in the 1880s and again in 1920s was already in ruins prior to the use of the ground above it as an Arab cemetery (**Figure 11**) (Lander 1984: 6; Caruana 1881; Zammit 1922; 1923).

### *Phase 6: Post-Roman period*

Details for this period are not clear in the 1983 report and because the pottery was found to be mixed with Medieval and Early Modern material, it was not studied. A quick glance at some of these deposits, however, indicates that levelling of the area may have taken place during or after the High or Late Medieval periods on account of the handmade pottery with a distinctive burnished red slip (Blagg, Bonanno and Luttrell 1990: 72-73). A few green/brown glazed sherds were also noted. Possible stone robbing is evident in the east section (**Figure 9**), which would indicate that the spoliation took place sometime after the mid-fourth-century collapse.

In conclusion, this excavation has provided crucial stratigraphic and ceramic evidence for the possible decline of an urban space at least after the early to mid-fourth century AD. This date is consistent with the amphorae evidence gathered by Bruno, which has been taken to mark a decline in imported material at Tas-Silġ and San Pawl Milqi from the fourth century (Bruno and Cutajar 2013).

### *The pottery from the Melita Esplanade*

Just under 90% of the amphorae in the Melita Esplanade assemblage are imported forms (**Table 5**). The amphorae types range in date between the fourth century BC and the mid-fourth century AD (**Table 6**). Local forms are primarily composed of egg-shaped amphorae typical of the Punic period **A1**, but which are known from mid-first century AD contexts. At least five examples of these are most probably residual fragments. Later Roman-period local amphorae consist of two examples of Malta type 1 (second to first centuries BC) and a single Malta type 2 example (Early Imperial period), which may be residual too (types **A2** and **A3** respectively). A few Late Republican Tyrrhenian and Adriatic amphorae (Dressel 1, Dressel 2-4 and Lamboglia 2) sherds were scattered across Phases 1 to 5. The bulk of the recognised

<sup>16</sup> The glazed pottery found in Phase 6 has not been formally studied, therefore an Islamic date has not been confirmed, and is only suggested as a date by Lander in his report (1984: 7).

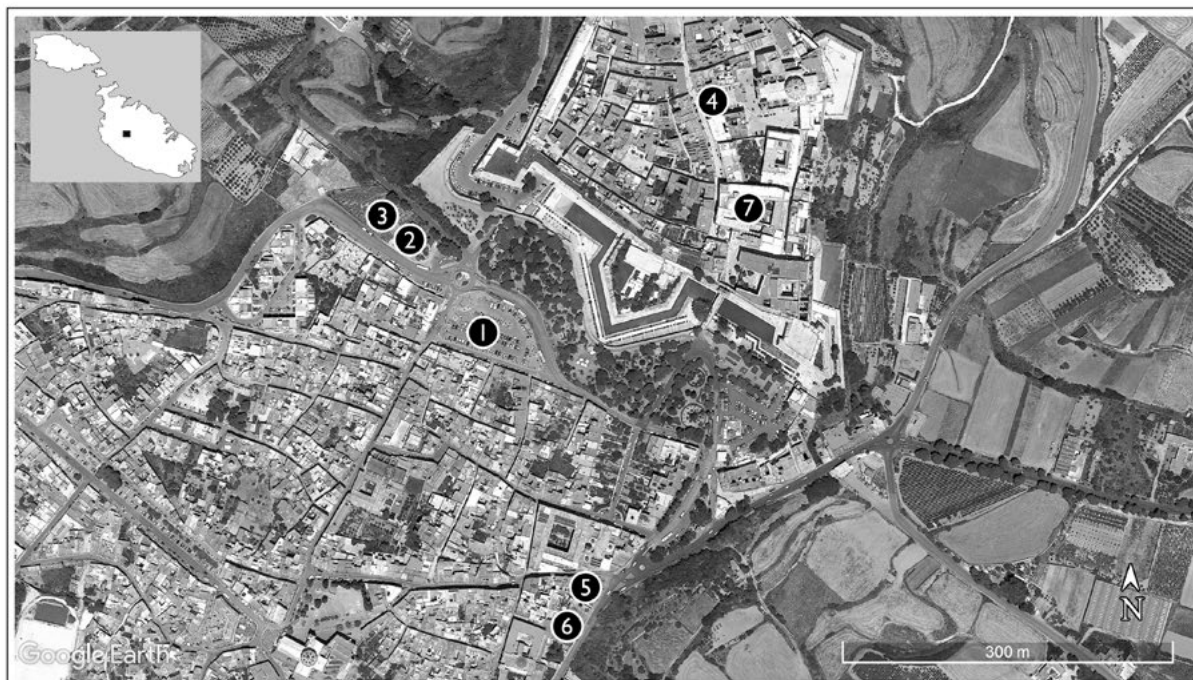

1) Location of the Melita esplanade trench; 2) Roman domus; 3) house remains excavated behind the domus in the 1920s; 4) Cathedral Square (remains of public building); 5-6) Remains of a tiled floor and Roman remains at Is-Saqqaġa; 7) St Peter's Monastery (possible location of a temple to Apollo).

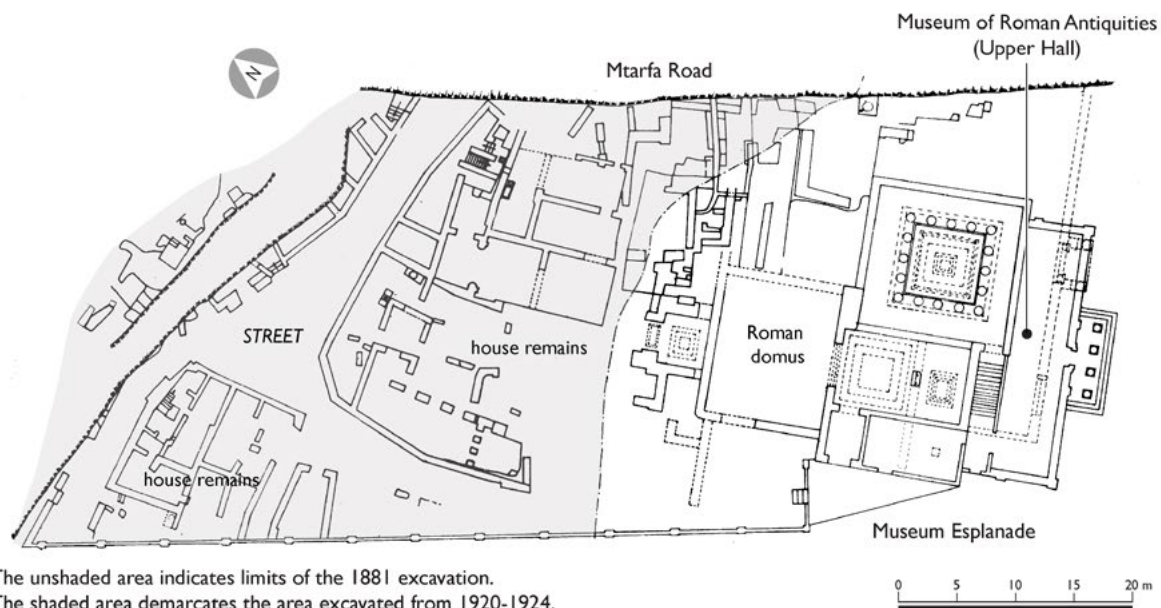

Figure 11: Aerial view of Mдина and Rabat, Malta, indicating the location of other Roman-period remains and finds (source: Google Earth); and (bottom) a plan of the Roman domus and other houses excavated in Rabat, Malta (after Gouder 1983).



Type	Import		Local		Total		Proportion of import/ local within each class	
	No.	%	No.	%	No.	%	Import (%)	Local (%)
Amphora	211	14.45	26	1.78	237	16.22	89.03	10.97
Cooking ware	210	14.38	90	6.16	300	20.54	70	30
Fine ware	89	6.1	145	9.99	235	16.08	38.03	61.97
Coarse ware	31	2.12	625	42.81	656	44.9	4.73	95.27
Prehistoric	0	0	33	2.26	33	2.26	0	100
<b>Total</b>	541	37.05	919	62.97	1461	100	-	-

Table 5: Number and percentage (RBHS) of imported and local pottery; and the proportion of imported versus local pottery from Museum Esplanade, Rabat, Malta (n=1461).

amphorae types are Sicilian (MRA 1a), Cretan (AC1 and 2), and North African (Africana IIA; IID; Tripolitanian I; Uzita, 52, 10; and Dressel 30s of probable Algerian production). These amphorae range in date between the mid-second and mid-fourth century AD. Two fragments of a LRA2 amphora from Phase 5 may date to between the fourth and seventh century AD. The latest ARS fine ware (Hayes 67) may be dated to the second half of the fourth century AD.

cooking wares make up a significant proportion of the Melita assemblage (Table 5), and 70% of these cooking wares are imported from North Africa, Pantelleria and Italy. Sixteen per cent (16%) of local wares are made in a handmade fabric (Local fabric 6), whilst 11.33% of local wheelmade sherds are in a fine red lime and glauconitic fabric (Local fabric 2) typical of the Early Imperial period. The imported cooking wares originate from Italy (8.33%), Pantelleria (12.67%), and North Tunisia (47%), with a further 2% from unknown provenances. Pantellerian and Tunisian cooking wares are most numerous in contexts belonging to the latest phases of the site (Phases 3-5). Besides the relative absence and/or scarcity of these forms – as well as the small number of sherds in general (n=36) – and fabrics in the two earlier phases (Phases 1-2), there are few patterns that can be discerned for the cooking wares in the assemblage. The Tunisian forms present are almost entirely from North Tunisian production centres, whilst four sherds may be Central Tunisian on the basis of the fabric. The majority of the forms are also typical of the imported repertoire of Tunisian exports between the second and fourth century AD (Hayes forms 181, 197, 196 and 185). A more detailed study of the sourcing of these North African examples was carried out by Victoria Leitch in April 2009. Although many of the sherds she looked at are not included in this body of material,<sup>17</sup> she did conclude

that the site received the ‘common classic forms’, as well as some of the earlier forms which date to the mid-first century AD (Leitch 2010: 319).

Fine wares account for about 16% of the total ceramic assemblage from the Melita Esplanade (Table 5). However, unlike the amphorae, imported examples make up only 38% of all fine wares; locally produced fine wares consist mainly of red slipped pottery (59.15%) and a few thin-walled vessels (2.98%). Their early date seems to indicate that a small fraction of the imported fine wares are most probably residual sherds, in particular the Campanian A and C black slip fragments and possibly the Italian *terra sigillata*. The remaining imported sherds (31.5%) are entirely of North Tunisian ARS production which dates from the mid-third to early-to-mid fourth century AD.

### Local Maltese potteries

Pottery has been produced on the Maltese islands since the Neolithic period.<sup>18</sup> During the Roman period, all kinds of pottery vessels, including amphorae, fine slipped wares, cooking vessels and plain utilitarian pottery were manufactured locally, with ancient potters utilising a wide range of clay and temper mixtures to achieve the best results. Locally manufactured vessels tend to be very distinctive and in most instances can be easily told apart from imported fabrics and forms. A considerable proportion of the assemblages included in this study confirmed the prevalence of a local pottery tradition on Malta and Gozo during the island’s Roman

material but did not have access to the excavation notes at this time (Leitch 2010: 319). The same fragments included in this study were selected on the stratigraphic information obtained at a later date. Due to this some of the forms she identified are not included here.

<sup>18</sup> The manufacture of prehistoric pottery in the Maltese islands was the subject of a doctoral dissertation by M. Molitor (1988).

<sup>17</sup> Leitch looked at material from 34 wooden crates storing the

Amphora type	Provenance	Content/s	Date	No.	%
Punic egg-shape	Malta	Oil, wine?	4th c. BC–1st c. AD	13	5.5
Van de Werff 1	N. Tunisia (N. Africa)	Garum?	2nd–1st c. BC	3	1.3
Mana D (Ramon T-4.2.1.5 and T-52.3.2/1)	N. Tunisia (N. Africa)	Garum?	4th–2nd c. BC?	2	0.8
Dressel 1	Campania (S. Italy)	Wine	mid-2nd–end of 1st c. BC	4	1.7
Dressel 2-4	Campania (S. Italy)	Wine; Falerian(?) - ‘praised vintage’	Mid-1st c. BC–end of 1st c. AD	2	0.8
Lamboglia 2	Adriatic (S. Italy)	Wine, olive oil(?)	2nd–end of 1st c. BC	1	0.4
Malta type 1	Malta	Oil, fish sauce	End 2nd–end 1st c. BC	2	0.8
MRA 1b	Sicily	Wine	Mid-1st–mid-2nd c. AD	2	0.8
MRA 1a	Sicily	Wine	Mid-2nd–mid-/late 4th c. AD	15	6.3
MRA 1	Sicily	Wine	-	14	5.9
Malta type 2	Malta	?	1st–2nd c. AD	1	0.4
Crétoise 1	Crete	Wine?	Early 1st–mid-4th c. AD	2	0.8
Crétoise 2	Crete	Wine?	Early 1st–beg. 3rd c. AD	2	0.8
Africana IIA	N./C. Tunisia	Wine, fish sauce?	Mid-2nd–end 3rd c. AD?	4	1.7
Africana IID	C. Tunisia	Wine, Fish sauce?	Mid-/end 3rd–4th c. AD?	1	0.4
Africana II type	N. Tunisia	-	c. 2nd–4th c. AD	1	0.4
Africana II type	C. Tunisia	-	c. 2nd–4th c. AD	2	0.8
Uzita, 52, 10	C. Tunisia (Salakta?)	Fish sauce?	End 1st–2nd c. AD	1	0.4
Tripolitanian I	Tripolitania	Oil	1st–mid-2nd c. AD	1	0.4
Dressel 30/Keay 1A	Mauritania (N. Africa)	Wine	3rd c. AD	7	3
LRA2	East Aegean	Oil, wine	Early 4th–beg. 7th c. AD	2	0.8
Unknown (Punic)	Import	-	-	1	0.4
Unknown (Punic)	N. Africa	-	-	6	2.5
Unknown	Local	-	-	10	4.2
Unknown	Import	-	-	138	58.2
				237	100

Table 6: Amphorae types from the Melita Esplanade.

period. However, details pertaining to production sites on the islands – the ‘ground zero’ when isolating local pottery sources – remain frustratingly scarce.

In his 1899 publication, A. A. Caruana refers to the discovery of two possible kiln and pottery workshops: one in a now unknown location in Gozo, and discovered in 1728; and a second one in a locality known as Xagħret-Medewiet, close to the ancient sanctuary site of Tas-Silġ (Caruana 1899: 3). However, no official records or finds collected from the site were preserved, and the sites themselves remain to be identified. Indeed, it is not impossible to think that a pottery workshop was located within the vicinity of that sanctuary, in part due to the vast number of inscribed votive bowls and plates, which were excavated from midden deposits surrounding the sanctuary (Bonanno and Vella 2015; Sagona 2015). The inscriptions themselves are thought to be abbreviated references to cultic terms probably associated with

the worship of the Phoenico-Punic goddess Astarte believed to have been worshipped at the sanctuary (Frendo and Mizzi 2015: 530). Each inscription was clearly scratched onto the soft clay surface of each vessel, and *then* fired, strongly suggesting manufacture within the immediate vicinity (Bruno 2009: 111). The same workshop also ‘supplied’ utilitarian wares to the inhabitants of the nearby Żejtun villa in the second/first century BC (Anastasi 2012: 32). As mentioned above, the standardised set of local forms found alongside wasters and ash from Foreman Street in Gozo are tell-tale signs for a pottery workshop, which existed at the site or within the vicinity. Unfortunately, no kiln features were discovered associated with these ash deposits. A rescue-led excavation at a site in Żebbiegħ, in the north of Malta, in 2006 revealed a similar mixture of ash and ‘classical ceramics’. Initial reports made by the excavators suggest that this too belonged to a

pottery kiln.<sup>19</sup> However, the report and details about the pottery forms from the alleged kiln remain to be completed. Lastly, another rescue-led archaeological investigation at Tal-Qares, on the outskirts of Mosta, also uncovered what has initially been interpreted as a pottery kiln. A preliminary site report outlining the remains discovered is available (Cutajar and Spiteri 2014), but analysis of the pottery is still required.

A brief account of the Oxford Anthropological Expedition's visit to Malta in the early 1920s describes the pottery making methods at the time (Dudley Buxton and Hort 1921), one described as old, the other more recent, and indeed having been introduced to the island only ten years previously. Although effectively describing a family run industry that existed just over one hundred years ago, the description of the 'older' method of making pottery provides some interesting clues about a local pottery tradition, which probably saw little dramatic change for at least two, if not more, millennia. The moulding took place on a simple potter's wheel affixed to a baked clay pivot in the shape of a conical frustum (Dudley Buxton and Hort 1921: 130, fig. 2).<sup>20</sup> The anthropologists go on to describe the rest of the manufacturing process. The completed pottery was fired in 'simple kilns', which were sealed with bricks during firing. Primarily brushwood was used as fuel, but when available, recycled wood – notably from broken boats – was also used. Interestingly, Dudley Buxton and Hort note that the quality of the clay that came from *Birchicara* (Birkirkara) was generally not suitable for high firing temperatures and subsequently had to be slowly fired to prevent it from vitrifying. Additionally, potters were also unable to produce highly polished vessels on account of the clay's quality. Presumably, the clay contained a high proportion of naturally occurring impurities, which were not, or could not be sufficiently extracted through the process of levigation. Salt that was released from the wood from recycled boats is said to have turned the clay white during firing (Dudley Buxton and Hort 1921: 131). Interestingly, a similar observation of white-skinned pottery was made by D. Peacock of modern potters in coastal Tunisia. He observed that salt water added to clay caused the pottery to turn white when fired (Peacock 1984b). The white-coloured skin on examples of Maltese Punic and Roman pottery is probably the result of a similar treatment. Lastly, raw clay was also extracted from beyond a village's immediate vicinity. Potters from the village of *Zeitun* (Żejtun) used much finer clay which was brought over from Gozo (Dudley Buxton and Hort 1921: 131).

Today, very little is known about Malta's ancient and historical pottery manufacture, however, Dudley Buxton and Hort's short note does help explain why such little archaeological evidence remains of these small industries. Firstly, these workshops were family run, presumably at a small private residence and serviced the local needs of the immediate village inhabitants and those in the vicinity. The one in Żejtun and on Gozo presumably also fulfilled a similar utilitarian function for local residents. It is more challenging to identify archaeological traces of small individual potteries like the ones described than it would be to identify larger, more specialised workshops aimed at mass producing a small range of vessels (Peacock 1982: 166). Secondly, the simple kilns would potentially turn invisible in the archaeological record, and this is partly one major reason why no unequivocal potter's kilns have ever been recorded on the Maltese islands. Indeed, it is not uncommon for local pottery manufacturers to fire pottery in small, structurally uncomplicated kiln pits, which nevertheless are sufficient to fire high-quality vessels. Thirdly, the thrifty nature of the islanders is apparent in the preference of collecting and using ancient pottery sherds as aggregate in a mixture used to waterproof flat roofs (Dudley Buxton and Hort 1921: 131). It is possible this practice encouraged the large-scale collection of ancient pottery, probably from the very production sites that would have left a high concentration of pottery waste – and which we subsequently have difficulty locating today.

<sup>19</sup> See short notification on: [http://www.fastionline.org/micro\\_view.php?itemkey=fst\\_cd&fst\\_cd=A1AC\\_1159](http://www.fastionline.org/micro_view.php?itemkey=fst_cd&fst_cd=A1AC_1159). Last accessed on 03/04/2019.

<sup>20</sup> Handmade pottery made without the use of a wheel was also known to have been produced in Żurriq in the mid-17th century (Abela 1647: 102; Luttrell 1975: 13).

## Chronology and a discussion of the import trends

The pottery data from the three sites were used to trace the import trends spanning the Late Republican/Early Imperial period through to the mid-fourth century. The chronology was established based on the dating parallels sought for the three different assemblages and how they were understood within the context of the stratigraphy.

As a group, the quantified evidence calculated from the three assemblages offered a first assessment of tracing the trends of imported pottery to the islands throughout the first four centuries of the Roman empire. The following section attempts to discuss these trends using the proportion of local and imported pottery present on the islands throughout the Roman period.

### Early Roman period

The pottery from the Bulebel quarry assemblage (Phases 1-2) provided the bulk of the evidence for the Early Roman period (end of the first century BC-mid-/end of the first century AD) (**Figure 12**). The amphora types identified in Phase 1 are dominated by imported Italian wine amphorae (Dressel 1 and Lamboglia 2 types) and local Roman types (Malta type 1) believed to have carried olive oil and a type of fish sauce, *garum* (Bruno 2009: 112-113). The remaining types belonging to this phase either could not be confidently identified or belonged to residual forms (i.e. Punic-period 'egg-shaped' amphorae or Greco-Italic forms). Punic 'egg-shaped' forms are however known from first-century -BC contexts so they may have been used alongside the Roman-period Malta type 1. Two Spanish, two Sicilian and one east Mediterranean body sherd tell us little about the types reaching the site, but if they are contemporary may suggest a small influx of non-Italian sources. The few North African wall fragments share a similar fabric to Punic types from North Tunisia and are probably residual. The presence of a single fragment of a Van der Werff 1 amphora in Phase 2 supports this.

The picture changes little in the site's second phase: Italian wine amphorae (Dressel 2-4) still dominate but are now accompanied by Eastern Sicilian wine amphorae from Catania (MRA 1b) and Naxos (ERA 13). The presence of earlier forms (namely Dressel 1 and Lamboglia 2) may be residual now, but the Malta type 1 sherds present in Phase 2 contexts may still be contemporary with those in Phase 1. Either way, the Maltese amphorae in Phase 2 decrease in number. One eastern Mediterranean wine amphora (Crétoise 4/ Dressel 43) has been identified and suggests that there was some eastern material reaching the islands at this

time, albeit in small quantities. Aegean and eastern Mediterranean amphorae made up a greater proportion of the imported amphorae in early Imperial contexts at Tas-Silġ and San Pawl Milqi (Bruno 2009: 178-179, figs 27 and 34). The anomaly within the new assemblages may thus be explained by the large number of imported amphorae fragments that could not be assigned a source with certainty.<sup>21</sup>

The North African-sourced sherds are also a little difficult to interpret here as none can be assigned to a particular form, therefore we remain uncertain as to whether these sherds belonged to residual Punic, or intrusive Roman, or contemporary forms. If context is taken into consideration, however, two different amphorae – consisting of a combined total of 265 sherds, which make up at least two-thirds of the entire vessel – from North Tunisia and South/Central Tunisia were found in the same context in one of the stratigraphically latest layers. These are probably types that belong to the Africana series and may be contemporary with the furnishing of the tombs (see below). In the absence of any diagnostic rims, the only base peg associated with a North African source seems to point towards this conclusion.

The amphorae evidence from Melita, Phase 1, is inconclusive, but the types identified do not contradict the patterns observed at Bulebel (**Figures 13 and 14**).

The fine ware evidence from Bulebel shows that the imported wares were significantly outnumbered by local red-slipped and thin-walled pottery (**Figure 16**). Of the imported fragments, most are residual (Greek and Hellenistic black-slipped wares). The presence of only two Italian sigillata bowls (**B36**) and one Knidian cup (**B28**) indicates that the import of fine wares was severely infrequent and thus the function that they performed was seemingly carried out by local types. A similar scenario is noted for the cooking ware assemblage, where again, local wheel- and handmade vessels are present and favoured above imported Italian dishes and pans. The southern Italian pans, some of which are Pompeian red ware dishes, are infrequent but do hint at a modest influx of these first-century-AD cooking pots. A locally potted shallow pan with a red-painted interior (**C19.2**) suggests that local potters

<sup>21</sup> A large number of wall fragments displaying a wide variety of fabrics were certainly imported, but it remained difficult to determine their source and type because of the lack of diagnostic features. However, these fragments are more likely to be from Adriatic or Aegean sources than any other regions as they are certainly not North African quartz-rich fabrics or Italian black sand fabrics. The fabrics associated with the imported diagnostic fragments within the three assemblages are described within each catalogue entry.

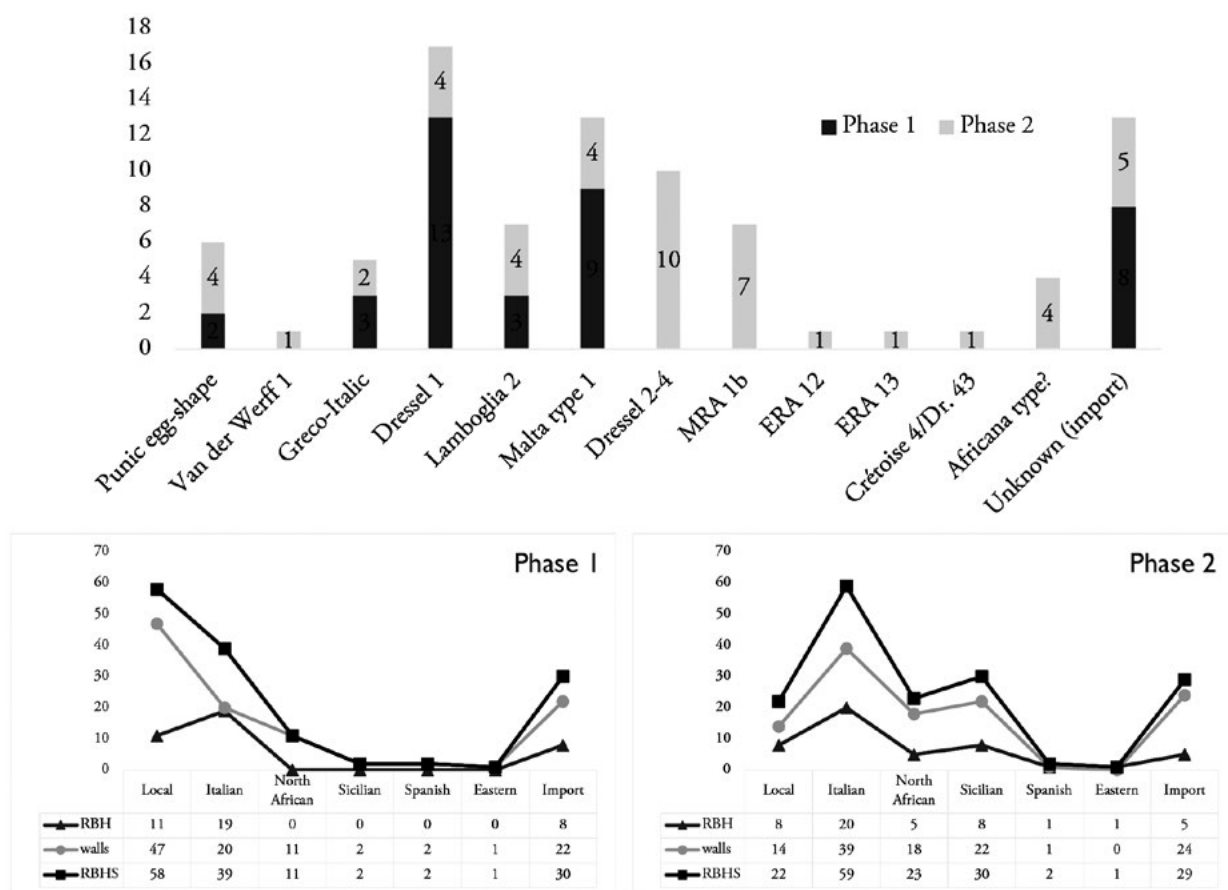

Figure 12: (top) Amphorae types (based on RBH); and comparison between count of walls, RBH and combined total for amphora in Phases 1 (bottom left) and 2 (bottom right) at Bulebel (n=309).

tried to replicate these pans. The sparse evidence from Melita Esplanade does little to add to, but neither contradicts, the evidence above (Figure 16).

What is evident for this period is that wine amphorae from Italian and Sicilian sources were being imported in proportionally significant numbers, whilst olive oil was mostly locally produced and supplied. The absence of imported amphorae associated with olive oil supports this and this pattern fits in with Bruno’s conclusion too (Bruno 2009: 172-180). The islanders did not, however, feel the need – or could afford – to import table and cooking wares from the same region. Instead a prolific local industry that supplied both rural and urban sites dominated the market. Determining whether this was an intentional choice by the islanders or was decided for them because of cost is difficult to determine. There is evidence of other imported objects (i.e. marble and coins), industrial structures, such as the numerous olive-processing farmsteads, which must have produced a fair amount of olive oil (Anastasi and Vella 2018), and ancient literary sources that lavish compliments on the skilled and revered textile industry (Bruno 2009: 86-88),

which all indicate that cost was not the inhibiting factor here. On the other hand, the evidence suggests that the organisation of trade of Italian table and cooking may have been different to that of wine (see below).

### Mid-Roman period

The picture for the Mid-Roman period (second-mid-third century AD) is based on the very scant material from Melita, Phase 2, and the homogenous assemblage at Foreman Street (Table 1). By virtue of the type of site, the patterns observed at Foreman Street have to be interpreted with caution as the assemblage is disproportionately composed of local coarse wares, which are believed to have been made in the vicinity. The remaining 8% of imported vessels does, however, add some useful information about what types of imported pottery were reaching the islands at the beginning of the third century.

Both assemblages generated very poor amphorae evidence. The handful of types identified at Melita are similar in composition to the previous period but it

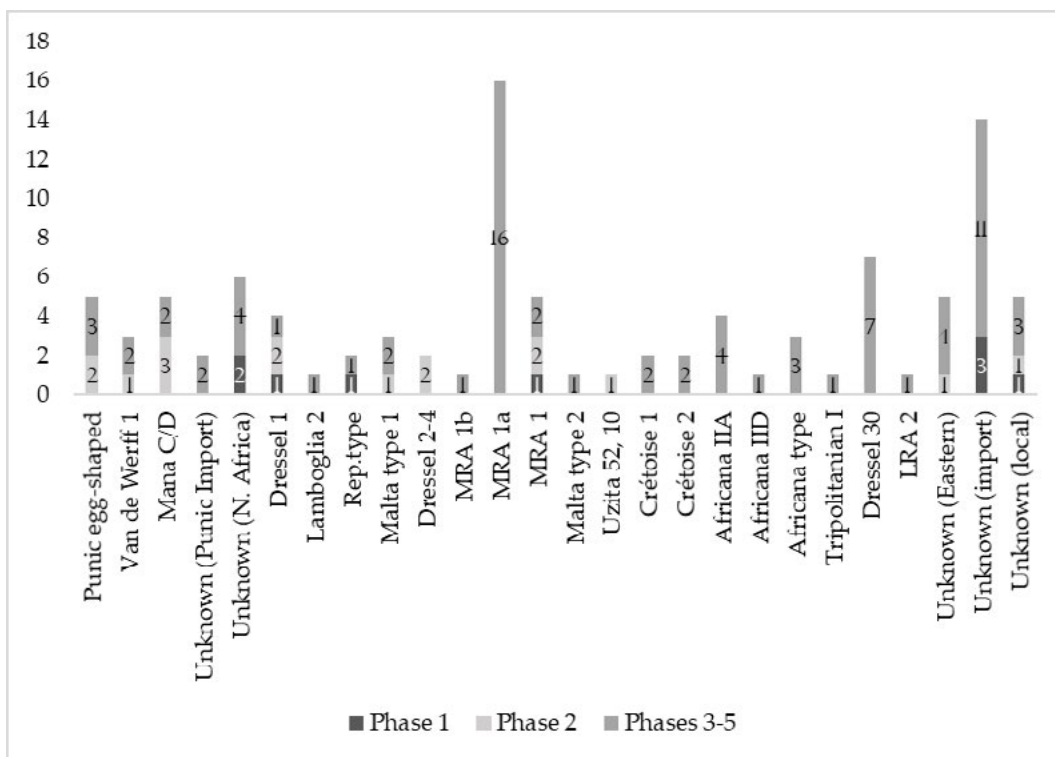

Figure 13: Number of diagnostic amphora types identified at Melita (n=102).

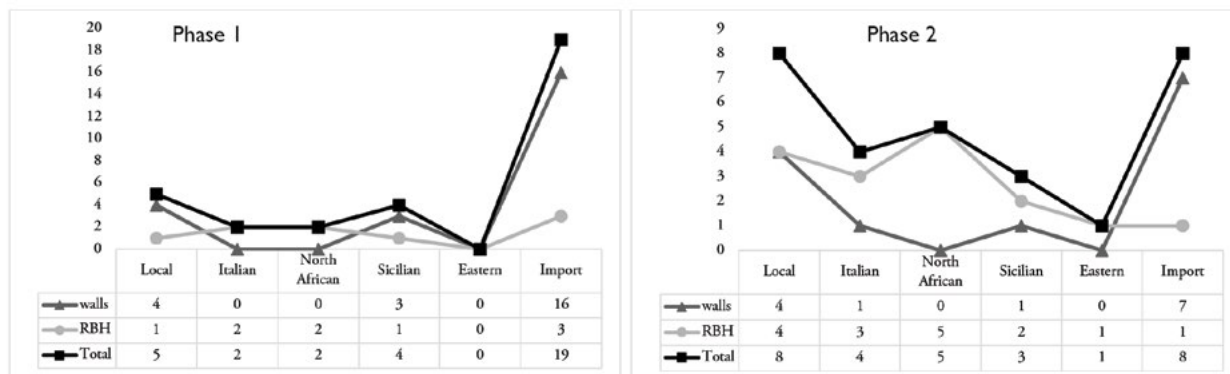

Figure 14: Comparison between count of walls, RBH and combined total for amphorae in Phases 1 (left) and 2 (right) at Melita (n=61).

appears with more residual sherds (Figure 13). Foreman Street produced only four diagnostic fragments. When the rest of the body sherds were grouped according to region of origin, one can tentatively conclude that North and Central Tunisian amphorae were significant (Figure 15). Adriatic fabrics are also well represented. A few eastern-sourced sherds were also present. The presence of just one local amphora sherd (Malta type 2) indicates that amphorae were certainly not being produced close by. The first/second-century date for this form may also make the sherd residual, however,

aside from a handful of clearly Punic and Early Roman small and worn sherds, the assemblage is fairly homogenous with a low incidence of residuality.

Fortunately, the Foreman Street site produced far better fine and cooking ware evidence for the period (Figures 16 and 18). Although proportionately still low (when compared with the coarse wares), better diagnostic sherds were available for study. Just over a third of the cooking ware sherds recorded could be assigned, with some certainty, to a type and these were predominantly

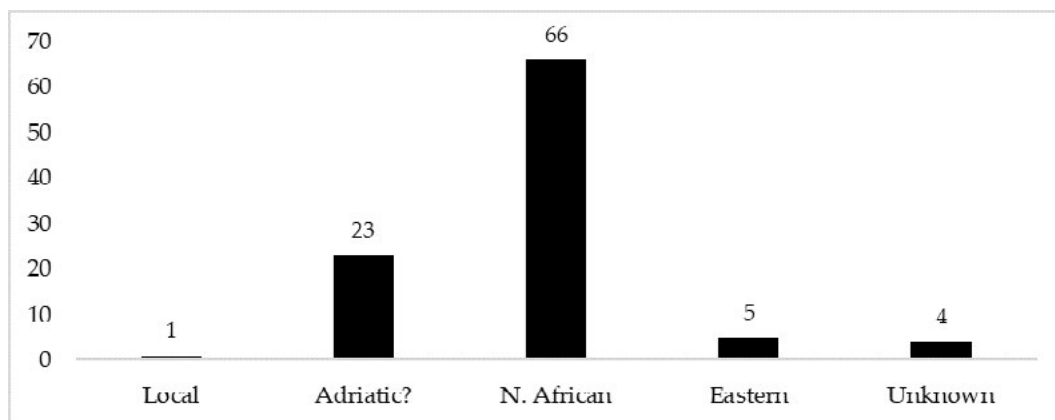

Figure 15: Quantity (based on RBHS) of amphorae from Foreman Street (n=99).

composed of North African and Pantellerian ware casseroles and lids typical of the period. The remaining sherds still belonged to these two sources. Local cooking wares are represented by 11 small handmade fragments. This, together with the complete absence of local wheelmade forms, is an interesting contrast to what was noted in the previous period and assemblage. As will be demonstrated below, a preference towards imported rather than local cooking wares seems apparent for the later Roman period.

The ratio of local against imported fine wares is more balanced here (**Table 4**). Local red-slipped pottery forms dominate 55% of the group. African Red Slip ware, although composed of mainly undiagnostic ARS A and C fragments, makes up 28% of all fine wares, whilst making up 63% of the imported examples. A handful of fragments belonged to Corinthian Relief ware bowls, and even though the numbers are small, the fact that 7% of this assemblage is made up of this ware may be significant. To my knowledge, this third-century import has only been reported on Malta in one tomb context (Sagona 2002: 1063, fig. 202.2), but relief ware bowls of Hellenistic date (i.e. Megarian relief ware bowls) appear to be slightly more common judging by their presence in funerary (Sagona 2002: 1113, fig. 243.1) and urban contexts (Zammit 1923: 221, figs 1-3; Bonanno 2005: 168).

Taken all together the pottery data suggest that from the second century onwards, the islands – or Gozo to be more precise – witness a greater influx of imported non-agricultural specialised goods like table wares and cooking pots, at a rate not really seen before. Perhaps this is a consequence of the rise of North Tunisia as a major producer of utilitarian pottery vessels, namely ARS and African cooking wares, which reflect an unprecedented increase in the volume of goods that were exported within the central Mediterranean (for

a discussion of ARS distribution see Bonifay 2004. For African cooking wares, see Leitch 2013). However, since the islands were never a major importer of these types of goods whilst others, mainly wine amphorae, were still being imported, it seems more probable that Maltese inhabitants were active in deciding what to import or not, rather than the island's geography or wealth being the determining factor. Neighbouring small islands like Pantelleria have evidence of much greater volumes of Hellenistic and early Roman fine and cooking ware types during the same period (Anastasi 2018: 138-139).

#### Later Roman period

For the later Roman period (mid-third to mid-fourth century AD), three mid-third-century ARS dishes (one Hayes 31 [B40.3] and two Hayes 50A [B40.11]) were each found associated with local red-slipped and coarse ware vessels in two of the tombs dug into the side of the disused Bulebel quarry. The same ARS forms have been documented in several other tombs on the island and provide some of the best dating evidence for Roman-period tomb use on Malta (Sagona 2002: 1141-2). It is this mid-third-century group that the two North African amphorae from the latest stratigraphic horizon of the Bulebel quarry fill (see above) are probably contemporary with. In addition to the amphorae, two North African casseroles (C31.1-2), clearly dateable to the mid-second-early third century, but found mixed with the Phase 2, first-century-AD levelling material for the quarry, are also chance losses associated with the cutting of the tombs rather than the levelling of the quarry itself.

The last three Melita Esplanade phases provide the best quantified range of assemblages for this period (**Figures 13 and 17**). Late third-early-fourth century Eastern Sicilian wine amphorae (A13) were the primary import at this time, together with North African wine

containers, possibly from Mauretania (A22). Cretan wine was also trickling in as well as wine or fish sauce from Tunisia. No definite imported oil amphorae dating to this period have been recorded, however, neither are there any known locally produced vessels that made up for this. The latest date for the Malta type 2 is believed to be the end of the second century, and judging by the local types identified in this assemblage, they all appear to be residual. Bruno remarks that from the end of the second century, all Tunisian and Tripolitanian amphorae imported into the island carried oil or fish sauce (Bruno 2009: 182), but new evidence suggests that some of the amphora types she took to represent oil (A19) are now known to have contained wine instead (Bonifay 2004: 474, table IV). The high incidence of unidentified imported amphorae may have fulfilled the role of oil containers instead. Recent excavations at the Żejtun villa are indicating that the olive-pressing facility, built sometime after the second century BC, was still in partial use during this period, so there is evidence that the island was still capable of producing its own oil (Anastasi 2010: 106-107; Anastasi and Vella 2018). The amphora evidence from the 1972 excavation, although incomplete, does not contradict the Melita Esplanade evidence in terms of what was being imported into the islands at the time (Anastasi 2010: 129).

Fine wares are still dominated by local red-slipped forms (60%) but are supplemented by ARS dishes (Hayes forms 44 [B40.8], 45 [B40.9-10] and 50 [B40.12] – the latter being the most common) which make up the lion’s share of imports (Figure 16). The remaining 5% of imports are residual and Hellenistic and early Roman in date. Only two sherds can be assigned to an eastern Mediterranean source. Local thin-walled wares are also starkly under-represented when compared with the earlier first-century-AD assemblage at Bulebel.

Over half of the imported cooking wares are North African and are made up of types belonging to the typical exported vessels of the period (C31, C34 and C36). Local cooking wares comprise about 25% of the total cooking ware assemblage and consist of both wheel- and handmade forms. Pantellerian ware casseroles (C46-8) make up another 14% of the assemblage, a marked decrease when compared with the Foreman Street pots. The Italian forms (c. 6%) are mainly composed of walls but two globular ribbed cooking pots may belong to a late Eastern series dated to the mid-fourth century (Riley 1979: 270).

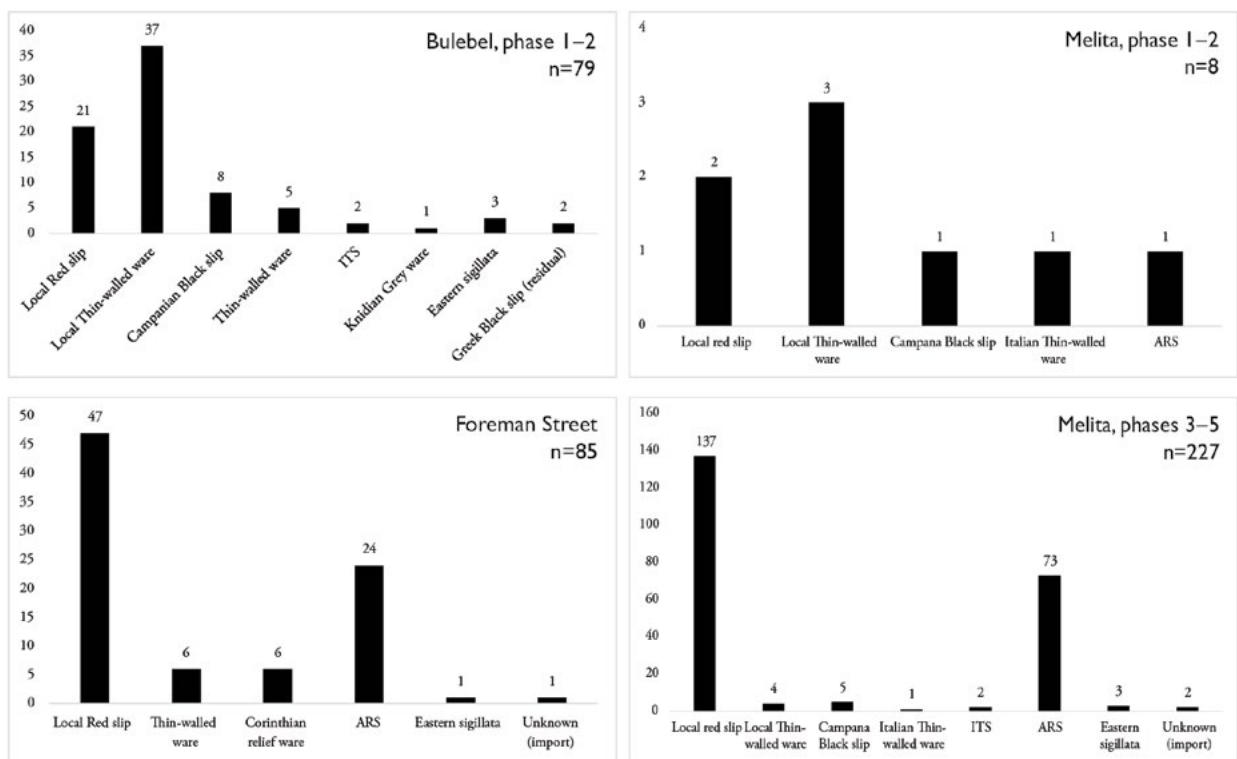

Figure 16: Quantification of fine wares from the three sites.



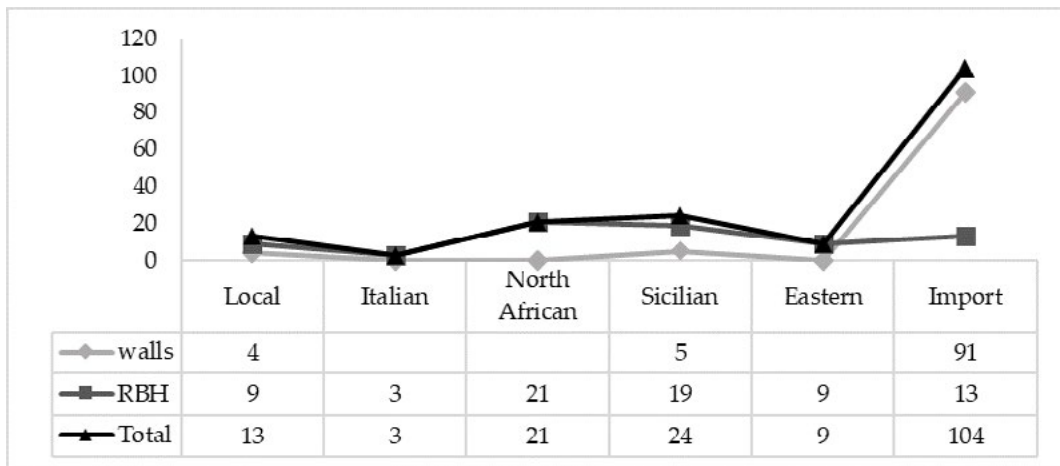

Figure 17: Comparison between count of walls, RBH and combined total for amphorae in Phases 3-5 at Melita (n=174).

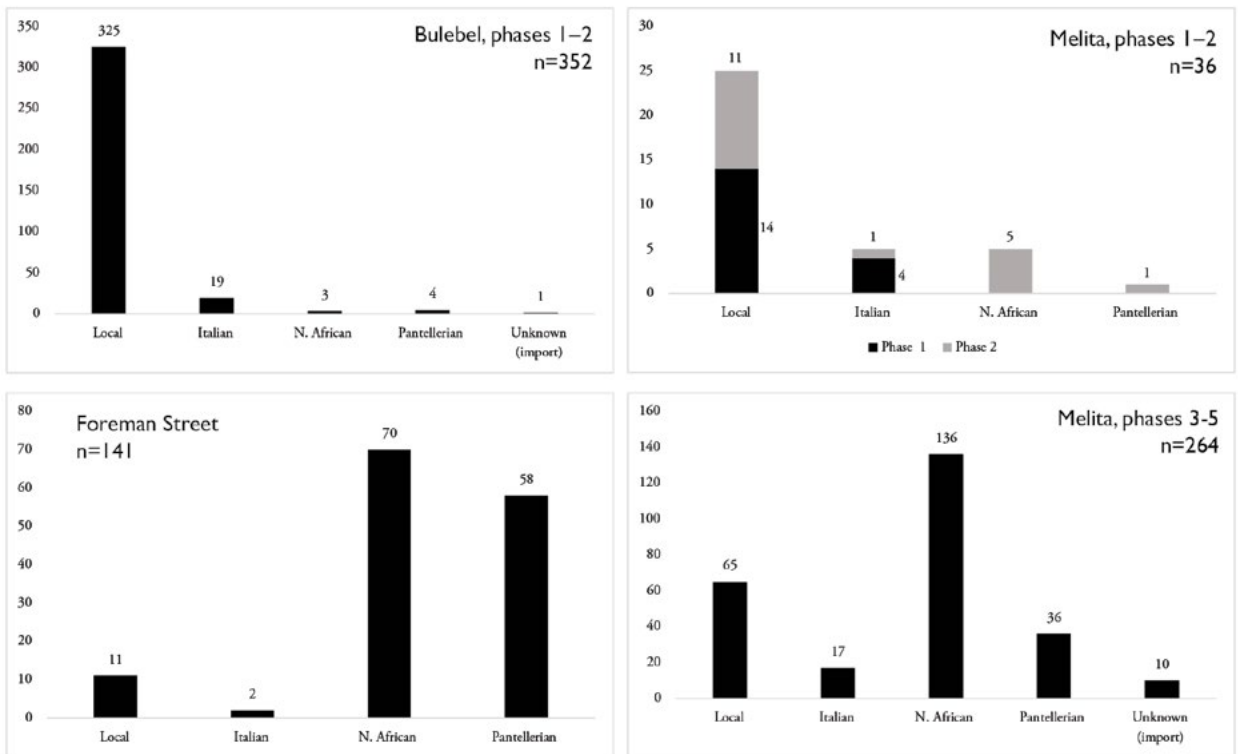

Figure 18: Quantification of cooking wares from the three sites.

## General conclusion

This study was conceived and executed with the purpose of examining an important body of Roman-period ceramic material from the Maltese Islands. With it has come the opportunity to further understand one aspect of the local Maltese economy, both in terms of what ceramic forms were being produced on the islands, but also what types of pottery vessels were being imported from overseas. This was done in a bid to build on the seminal work of other scholars who have studied Maltese Roman-period pottery.

Although the number of fragments making up these three assemblages may be considered small, the composition of these assemblages has nevertheless highlighted key trends that in many instances support existing interpretations of the ancient Maltese economy. This study has traced the imported pottery reaching the Maltese islands from the first to mid-fourth century, by combining important amphorae, cooking ware and fine ware data to assess the relative quantity and range of commodities consumed by the ancient Maltese. Indeed, larger assemblages from a wider array of Maltese sites are required for a better assessment of the islands' economic past. However, the material that was available for study has brought us one step closer towards holistically investigating these important economic proxies. In light of this, I wish to draw two concluding points:

Firstly, the evidence obtained from a consideration of the quantified assemblages has highlighted that locally made pottery vessels associated with eating, drinking and food preparation were always an important component of any local pottery assemblage. Of significance here is the high prevalence of local fine wares and the broad range of utilitarian vessels, which contrasts quite significantly with assemblages from neighbouring small islands like Pantelleria, where imported pottery significantly outnumbers local production. In contrast local cooking wares quickly get replaced by popular imported varieties, especially those from North Tunisia, perhaps due to the improved quality of these vessels achieved by the addition of quartz in their fabrics (Leitch 2013: 283).

Secondly, in spite of the patchy amphorae evidence from the three assemblages, the general patterns obtained supports the main conclusions drawn by Bruno for the amphorae from Tas-Silġ and San Pawl Milqi: namely, identifying a wide range of different types of wine amphorae imported to the islands throughout the Roman period. Wine containers

from eastern Sicily were also particularly popular, in many cases, more so than any other regional import. In contrast, local amphorae, most probably carrying olive oil, were more common in the early Roman period, but are not visible in the assemblages of the mid- and later Roman periods. However, this contrasts with the evidence derived from olive oil pressing farms around Malta, which indicates that olive oil was still being produced in the Imperial, and possibly Late Roman periods (Anastasi and Vella 2018). Therefore, the olive oil could have then been stored and transported to various localities in different containers, which we have yet to identify in the archaeological record.

This study is by no means the final word on the state of our knowledge of Roman pottery on the Maltese islands. Rather it is envisaged as a nudge to better record and understand a large body of data that is often overlooked. Despite the Roman period having a rich archaeological past on the islands, our ability to isolate and distinguish between types of local pottery forms has repercussions in the way we date and interpret our sites. Suggesting new dates for local forms is crucial for assemblages where imports are rare, as is often the case in early Roman rural sites. The data produced here are not necessarily conclusive, however, with the discovery and timely publication of more well-stratified assemblages, it is hoped that this study can be used as an aid to building site chronologies with more confidence. Indeed, I welcome new archaeological data that can refine or alter the dates presented here.

The future of pottery studies in Malta is looking bright. Already a new generation of researchers is producing important new data in the field of fabric characterisation.<sup>22</sup> These results will be key to understanding local clay sources and pottery production. There is also much scope to continue to build and refine a typology of Roman pottery for the Maltese islands. Further stratified material will be essential for identifying period-specific variants and refining chronologies. A broader range of assemblages from different sites and contexts (i.e. public buildings, urban centres, rural sites, ports and funerary contexts) across Malta and Gozo will not only increase our current dataset, but also improve the resolution of the data to allow more nuance and sturdy interpretations

<sup>22</sup> See MaltaPot (<https://www.um.edu.mt/arts/classics-archaeo/projects/mariecuriefellowshipawardee>; last accessed 7 May 2019) for an overview of the recent work being carried out on the characterization of Maltese clays and Neolithic-period pottery; and the MA dissertation by G. Ascik (2018) on the characterization of pottery samples from Foreman Street, Gozo (see below).

for the islands' involvement in a central Mediterranean economy. More recording of imported fragments from stratified excavations will no doubt corroborate, but also expand on, existing conclusions concerning the breadth and density of import trends on the islands, whilst also offering opportunities to 'test' existing data associations for local pottery forms.

## Local Maltese fabrics

### Geology of the Maltese Islands

The Maltese islands are made up of a series of five layers of sedimentary rock – Upper Coralline limestone, Blue Clay, Globigerina limestone and Lower Coralline limestone – with the thinnest formation, Greensands, sandwiched between Upper Coralline and the Blue Clay beds (**Figure 19**). The islands' geology is relatively young, formed by sediments that accumulated within the shallow epicontinental sea bed during the Oligocene and Miocene epochs (c. 30-5 million years ago) (Pedley and Hughes Clarke 2002: 41). Each layer is composed of cemented sediments that are mostly made up of lime-rich skeletal remains in the form of shells and skeletal debris from aquatic plants and animals. The finer components of the sediments are composed of a mixture of very fine wind-blown clay particles, land-based dust and volcanic material (Pedley and Hughes Clarke 2002: 41).

The Blue Clay formation is the only clay source on the island and is composed of 'a marl and limey clay, mostly with more than 50% calcium carbon content' (Pedley and Hughes Clarke 2002: 41). In addition to this predominantly calcium carbonate-based content, a significant amount of 'crystallized spherules' of gypsum and calcite are present (**Figure 20**) (Techer *et al.* 2013: 831).<sup>1</sup> Frequently mixed into the top few feet of Blue Clay, as well the dry clay content collected at the base of loose eroding clay slopes, is the thin layer of Greensands, which when eroded, is the source of the glauconite mineral characteristic of several local Roman-period fabrics. The Greensands

<sup>1</sup> I am very grateful to Dr Daniel Vella (Department of Metallurgy and Materials Engineering, Faculty of Engineering, University of Malta) for confirming the presence of gypsum and calcite in geological samples taken from Maltese Blue Clay layers. The characterisation analysis was carried out using Micro Raman Spectroscopy in April 2019.

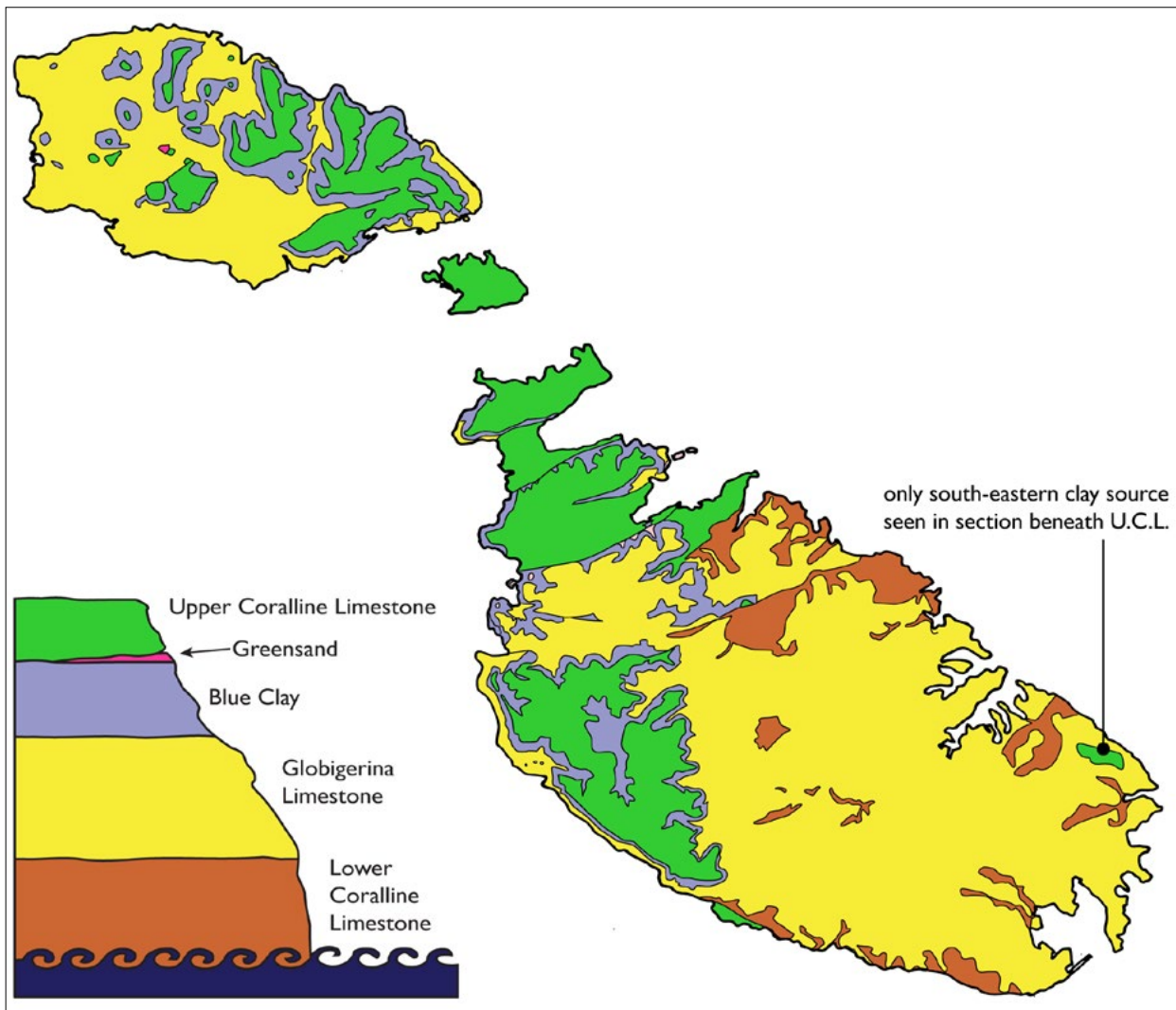

Figure 19: Schematic diagram showing the five main geological layers of the Maltese islands.

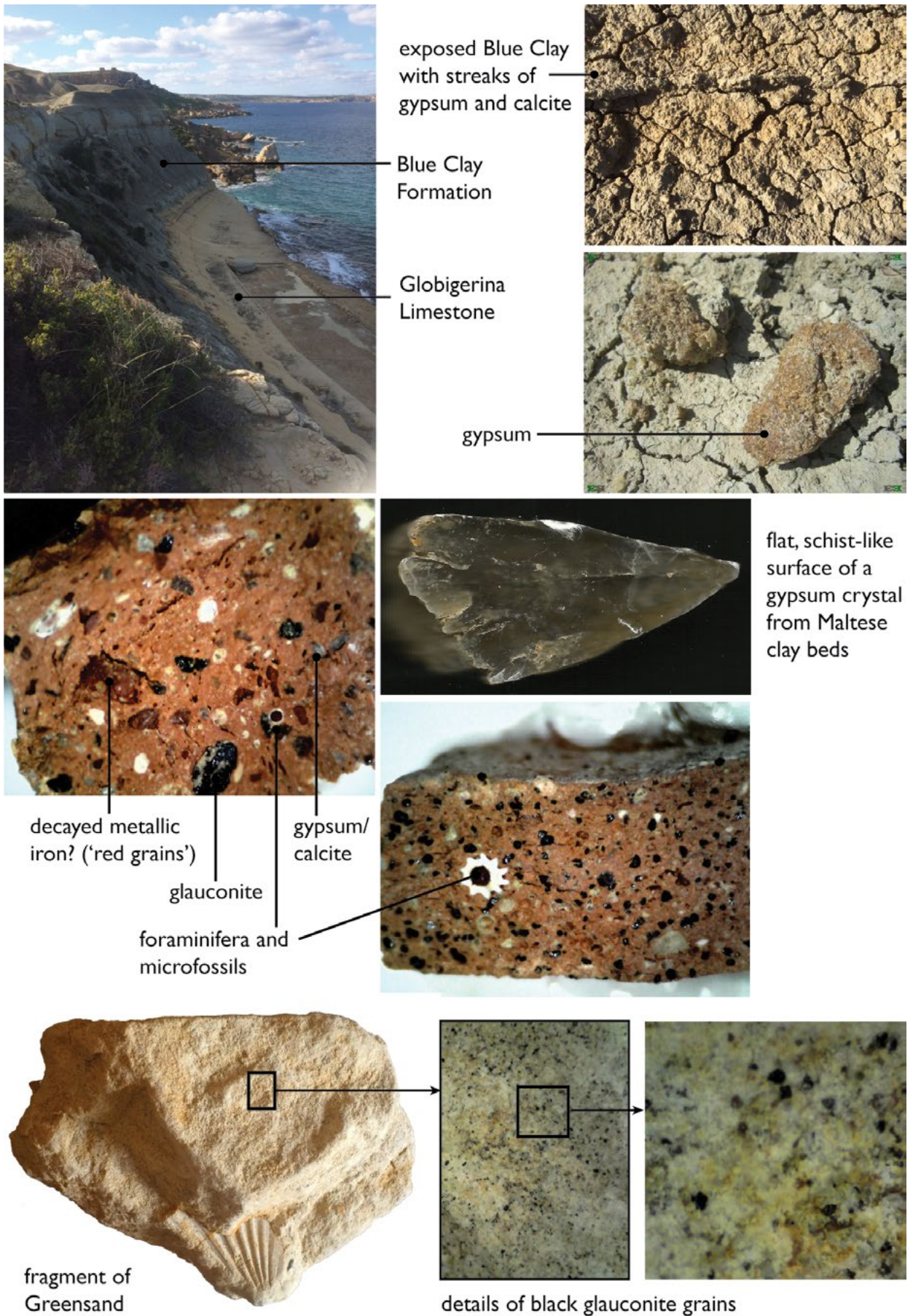

Figure 20: Possible sources and types of inclusions in Maltese pottery fabrics.



Figure 21: The thickest Greensands outcrop, il-Gelmus hill, on Gozo.  
The outcrop is a short distance from the Foreman Street site.

layer is usually no more than a few millimetres thick, but reaches about 11 m at the Il-Gelmus outcrop in Victoria, Gozo (Figures 4a and 21).

The material is a sand conglomerate composed of fossil detritus combined with brown phosphatic and rounded glauconite grains (Pedley and Hughes Clarke 2002: 56). Glauconite grains are green in colour when looked at through a microscope but appear black or brown when seen by eye or under low magnification. The predominant calcium carbonate content is made up of lots of fine white foraminifera, the remains of deep-sea unicellular organisms that form a calcium carbonate shell. The size of the organism can be under 1 mm, but can also be larger (Pedley and Hughes Clarke 2002: 46).

### A Classification of Maltese fabrics

Five common fabrics were identified across the three assemblages and are believed to be local in production. Currently, there are no known pottery kilns or related structures dating to the Late Punic or Roman periods on the Maltese islands. Evidence for a local pottery industry comes primarily from the fabrics, wasters and

the inscribed vessels from the sanctuary of Tas-Silġ, where thousands of bowls, plates and cooking pots were inscribed to the Punic goddess Astarte before they were fired (see above). Fortunately, the Foreman Street assemblage belonged to a pottery workshop dump as the mixture of ash and pottery wasters suggests this (see below).

The fabrics were identified and classified using a x20 handheld lens. At the time this research was being undertaken, it was not deemed possible to undertake detailed archaeometric analyses of the local fabrics.<sup>2</sup> The vast majority of fabrics and forms were quite clearly identifiable as local products through knowledge of the basic local geology and comparison with ubiquitous local pottery forms from tomb and ritual contexts. However, it is hoped that this study will offer an adequate basis,

<sup>2</sup> An attempt was made by Kristian Chetcuti Bonavita and Nick Vella in 2000 to undertake a study of the local clay sources throughout Malta. Several samples were taken from various locations, together with stratigraphic and geological details. The study never continued beyond the collection stage, however the same samples will be analysed as part of the MaltaPot project. See <https://www.um.edu.mt/arts/classics-archaeo/projects/mariecuriefellowshipawarddee>. Last accessed on 09/04/2019.

in the form of a local fabric classification, for future petrographic and archaeometric studies of the local material as has already started to be done for some Punic-period samples.<sup>3</sup>

Since 2015, a number of projects have commenced at the University of Malta in an effort to invest and develop local capabilities and expertise to carry out petrographic analyses on all types of Maltese pottery. Already preliminary petrographic analyses have begun on one fabric group discussed below (Local Fabric 2), from samples taken from a range of coarse wares from Foreman Street. The analyses of these samples are still being concluded and will not be discussed here.

### Local Fabric 1

This fabric makes up the overall majority of Classical-period pottery on the Maltese islands, both in Malta and Gozo. Vessels are made in a pale red/orange clay, sometimes with a reduced pale grey core. The matrix generally is coarse with small to large voids. The clay contains white or yellow-coloured lime and white foraminifera fossil inclusions (**Figure 22**). Red iron ore grains are also sometimes found mixed within the clay, as are small pale red clay pellets or grog. The surfaces of vessels made in this fabric can be coated in a white or cream-coloured slip or salt-slip. Late Punic and Roman-period coarse ware pottery tends to have an unslipped, wet-wiped surface, which is sometimes dry-shaved or burnished/polished to render the surface smooth. Most often, however, the surfaces are left untreated and are rough and gritty to the touch due to the coarse tempering.

Little is known about the methods involved in the firing of local vessels because of a lack of structural evidence, however, vessels are generally well-fired in oxidising conditions, suggesting that firing capabilities allowed temperatures to reach at least about 800°C. Fluxes in temperature, due to bonfire-type firing, probably account for the highly variable mottled surface colours typical of local pottery. Colours range from white, grey or cream to pale red, pink and yellow. In the Roman period, red-slipped vessels in this clay can also be found.

Claudia Sagona classified this generic fabric as ‘Crisp ware’ for the Punic and Late Punic pottery from the tombs discovered throughout Malta and Gozo and from the sanctuary at Tas-Silġ (Sagona 2002: 80-81; 2015: 50-67). B. Bruno identified this general fabric as the fabric used for Late Punic amphorae (egg-shaped forms) and the majority of Malta type 1 forms. Together with C. Capelli, Bruno characterised the clay composition in Malta type 1 forms from Tas-Silġ and San Pawl Milq

and classed them as group A (*generico*) (Bruno and Capelli 2000: 60-61; Bruno 2009: 109). More recently, B. Bechtold and K. Schmidt have characterised some Punic-period Maltese pottery fragments from the fourth-fifth-century BC deposits at the Żejtun villa, which also exhibit similar fabric qualities (Schmidt and Bechtold 2013).

coarse wares [BLB12: 903 (62.2%); FRM08: 30 (2.1%); MLT84: 522 (35.8%)]

Amphorae [BLB12: 72 (76.6%); MLT84: 22 (23.4%)]

cooking wares [BLB12: 9 (81.8%); MLT84: 2 (18.1%)]

Fine wares [BLB12: 7 (8.9%); FRM08: 1 (1.3%); MLT84: 71 (89.9%)]

Thin-walled wares: [BLB12: 1 (33.3%); MLT84: 2 (66.7%)]

### Local Fabric 2

This fabric is the second most common type of Maltese fabric, which starts appearing in the Late Punic period, but becomes very common from the Late Republican period onwards. The Roman-period local pottery on Gozo, at least during the second and third century AD, appears to be almost exclusively made using this type of fabric. The fabric is characterised by a soft-to-medium hard, well-fired clay with white or yellow lime fragments, white foraminifera fossil, and fine, round and shiny, black glauconite granules (**Figure 22**). The fabric is generally similar to Local Fabric 1 except for the finer matrix and peppered glauconite tempering. From at least the first century BC, this fabric makes up a significant part of coarse ware vessels including plates, bowls, jars, thin-walled cups and red-slipped fine wares. In general, coarse and fine ware shapes in this fabric tend to have thinner walls, which may be considered a Roman-period characteristic.

A similar fabric was identified and classified by Bruno (Group GL) for variants of the Malta type 1 and 2 amphora forms. The fabric made up a small percentage of her Malta type 1 amphorae assemblage from at least the second century BC (Bruno 2009: 104-105; Bruno and Capelli 2000: 61-62). Sagona identified a similar glauconite fabric, ‘Black gritty ware’ for the early Roman period (Sagona 2015: 72-73), as it did not appear to be common in Maltese tombs of the Late Punic period (Sagona 2002: 80). The majority of vessels at Foreman Street were made in this fabric, including most of red-slipped wares, and it is now thought to be close to the area where this pottery was produced on Gozo. Foreman Street is also located within a short distance from the largest Greensands outcrop on the Maltese islands (**Figure 21**). A recent study, carried out by as part of a Master’s project, characterised raw clay samples from Il-Gelmus outcrop and a selection of sherds from Foreman Street.<sup>4</sup> The results support the

<sup>3</sup> See [http://facem.at/map/production\\_site.php?id=61](http://facem.at/map/production_site.php?id=61). Last accessed on 24/08/2015.

<sup>4</sup> A total of six sherds were selected for characterisation (A3.1, B6.1,

LOCAL FABRIC 1



D76.2



A1.2



D76.1



D27.5



D71.4

LOCAL FABRIC 2

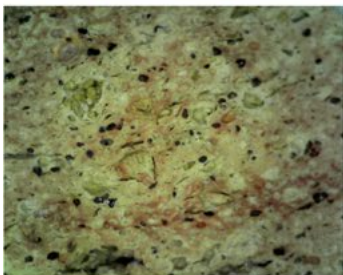

D26.1

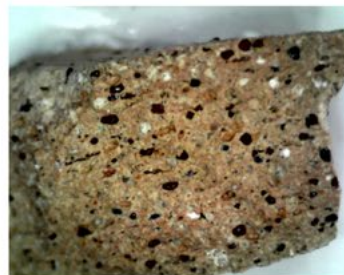

D10.6

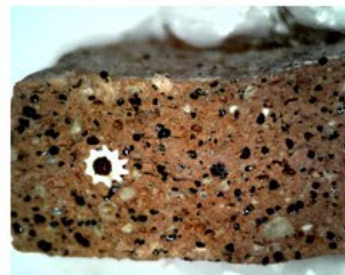

B23.12

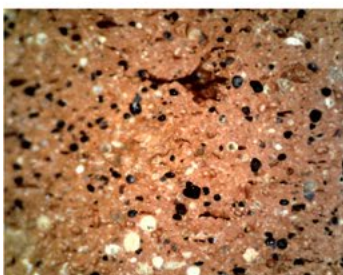

A2.4



D36.5



D12.3

Figure 22: Local Maltese fabrics 1-2.



possibility that the clay source could have been used to produce the glauconitic fabric prevalent at Foreman Street (Asciak 2018). However, since the compounds detected in the Gelmus clay samples are common to most raw clays, characterisation analyses of other Maltese clay sources are required to compare the data.

coarse wares [BLB12: 712 (17.7%); FRM08: 3216 (79.8%); MLT84: 101 (2.5%)]

Amphorae [BLB12: 11 (68.8%); MLT84: 5 (31.3%)]

cooking wares [BLB12: 7 (58.3%); MLT84: 5 (41.7%)]

Fine wares [BLB12: 16 (11%); FRM08: 46 (31.7%); MLT84: 83 (57.2%)]

Thin-walled wares [BLB12: 26 (96.3%); MLT84: 1 (3.7%)]

### Local Fabric 3

This fabric appears to be a combination of Local fabrics 1 and 2, and contains both lime and foraminifera inclusions as well as added angular crystalline inclusions, which probably belong to gypsum or calcite (**Figure 23**). Some variants of this fabric may also contain some glauconite content too, although, in far less quantities than that seen for Local Fabric 2. The surfaces tend to remain unslipped and exhibit a rough texture, where most of the inclusions remain visible. Very often, the gypsum/calcite inclusions give the surface a shiny, glittering look, and on occasion has been mistaken for a micaceous or quartz-rich fabric (for instance, see Sagona 2015: 80). Only a few examples in this fabric belong to thin-walled and red-slipped vessels, but it is more common in Late Republican/Early Imperial coarse ware bowls and plates from central and southern Maltese contexts, in particular Imperial-period deposits from Tas-Silġ.

coarse wares [BLB12: 86 (78.2%); MLT84: 24 (21.8%)]

Amphorae [BLB12: 1 (100%)]

cooking wares [BLB12: 1 (50%); MLT84: 1 (50%)]

Fine wares [BLB12: 2 (100%)]

Thin-walled wares [BLB12: 1 (100%)]

### Local Fabric 4

This is a very fine, hard-fired red to dark orange clay, which contains distinctive matt black spherical inclusions – possibly decomposed glauconite grains – and occasional white or yellow limey fossil inclusions (**Figure 23**). The first published reference recognising this fabric comes from the pottery report of the residual Roman-period material from Ħal Millieri, where the fabric was classified as ‘Fabric A’ (Blagg, Bonanno and Luttrell 1990: 54–56, fabric A). Quercia did not tackle local cooking ware fabrics in his studies, whilst Sagona’s references to ‘imported [?] Red Bricky Ware’ as the classification for some of the cooking vessels

discovered in funerary contexts were not specific enough to make an adequate comparison (Sagona 2002: 83). Her more recent study of the material from the University of Malta’s excavations at the sanctuary of Tas-Silġ assigns the fabric the label of ‘Late Red Bricky ware’ and concludes that it is a local fabric primarily used for the manufacture of thin-walled cooking vessels (Sagona 2015: 77).

This fabric is typical of local red-slipped fine wares, thin-walled wares and cooking wares, and can be mistaken for imported African and Sicilian wares because of the fine, granular nature of some examples. The presence of fine white foraminifera and the distinctive black inclusions do, however, betray its local source. Indeed, higher magnification of this fabric shows the same general inclusions seen in the coarser Local Fabric 5 samples (**Figure 23**) indicating that the Local Fabric 4 clays were intentionally better levigated.

coarse wares [BLB12: 12 (60%); FRM08: 1 (5%); MLT84: 7 (35%)]

cooking wares [BLB12: 27 (45.8%); MLT84: 32 (54.2%)]

Fine wares [BLB12: 2 (100%)]

Thin-walled wares: [BLB12: 9 (64.3%); MLT84: 5 (35.7%)]

### Local Fabric 5

This fabric is a coarser version of Local Fabric 4, characterised by a deep rust-coloured red/brown to brick-red coloured clay peppered with fine to large coarse white and yellow lime, foraminifera and fossil inclusions (**Figure 23**). Some black glauconite inclusions are also sometimes present, although they are rare (i.e. **A3.2**). Voids visible in the paste are common and the breaks are generally clean, but rough. Sagona classified this fabric as ‘Bricky Red ware’ for the University of Malta’s material from the sanctuary at Tas-Silġ, where it was found mostly associated with round-bottomed cooking pots (predominantly Quercia’s olla type B) dated to the fourth/third-second century BC (Sagona 2015: 74–77; Quercia 2002: 410–411, fig. 2).

Vessels made in this fabric are wheelmade and were either left unslipped or salt-slipped, where a thin white scum coats the surface. A large proportion of fabric-5 cooking vessels from Tas-Silġ contained Punic inscriptions evoking the Semitic goddess Astarte. These inscriptions were incised onto leather-hard vessels *before* firing, thus supporting a local Maltese source for this particular fabric. This local source has since been further supported by the fabric analysis undertaken on a series of samples from the same site (Mommensen *et al.* 2006: 86).

Within this sample it is clear that this fabric is not at all common in the Roman period. Indeed, early Roman cooking wares tend to use the finer version (Local

D10.3, D10.5, D15.4 and D40.5).

LOCAL FABRIC 3

---

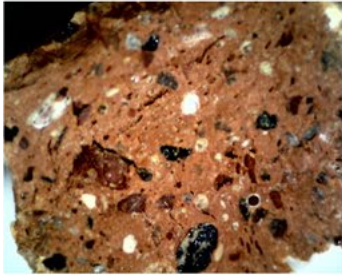

CI4.1



D27.3

LOCAL FABRIC 4

---



B23.10



B24.1

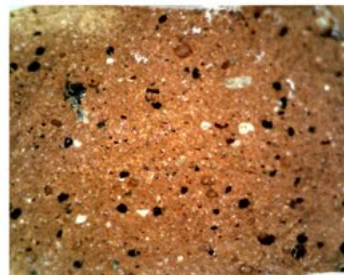

CI0.1

LOCAL FABRIC 5

---



CI1.3



CI1.1

LOCAL FABRIC 6

---



A3.2

LOCAL FABRIC 7

---



D71.2



CI6.1

Figure 23: Local Maltese fabrics 3-7.

Fabric 4), only adopting this fabric for a select number of forms (mainly types C7 and C11).

cooking wares [BLB12: 8 (80%); MLT84: 2 (20%)]

#### **Local Fabric 6**

This fabric represents two amphora rim sherds identified in the Foreman Street and Melita assemblages in the form of a Malta type 2 container (A3.1-2). Capelli and Bruno have identified and classified this particular fabric as ‘Group VQ’ or the ‘volcanic-quartz’ group, which is characterised by a dark orange/brown clay with lots of fine yellow and white foraminifera and fossil content, some rounded quartz, fine angular gypsum and fine black volcanic sand (**Figure 23**) (Bruno and Capelli 2000: 62-63; Bruno 2009: 110). According to Bruno’s description of the fabric ‘the abundance of rounded quartz granules strongly characterises the clays used in this group,’ however rounded quartz granules are not clearly present within the samples. Instead, fine angular flecks of transparent glass-like gypsum or calcite are in relative abundance, together with fine black, shiny volcanic glass. The lack of a larger sample of sherds in this fabric make it difficult to explore the composition of this fabric any further.

The type of quartz and volcanic material present within Bruno’s VQ fabric group – mostly associated with Malta type 2 amphorae – are not to be found in Maltese geological strata or beach sand. Bruno and Capelli surmise that the rounded marine, fluvial or wind-blown sand is akin to geographical areas like North African, Syrian and Palestinian desert regions. In spite of this, it cannot be excluded that some of this quartz content derived from material blown onto the Maltese islands from overseas. The *sirocco* wind that carries red Saharan sand does pass over the Maltese islands quite often, and when the dust clouds fall mixed within rain – blood rain – the gritty red sand falls to the ground, and leave a significant amount of desert sand on the ground. A similar phenomenon is known when volcanic material falls to the ground following volcanic activity from Mount Etna in nearby Sicily (Bruno 2009: 110). A recent study has demonstrated that ‘rare’ non-local volcanic inclusions were identified in locally made pottery dating to the Borg in-Nadur phase of the Maltese Bronze Age (Barone *et al.* 2015: 108, table 4). Nevertheless, Bruno concluded that the quantity of the volcanic and quartz material was too high to support a ‘wind-blown’ source for the tempering agents, but instead suggests that sand was imported into the islands and subsequently mixed with local clay to manufacture the amphorae (Bruno 2009: 110-111; Bonanno 2007: 522).

Interestingly, Bruno reports that this fabric group made up about 90% of the Malta type 2 amphorae from her

sample, but only four examples were actually from the sanctuary of Tas-Silġ. The overwhelming majority were exclusively from the San Pawl Milqi villa (Bruno 2009: 107). Therefore, the suggestion that ballast from incoming ships was discarded, or intentionally unloaded, on arrival and recycled as a tempering agent in mortar and clay, specifically at San Pawl Milqi, is possible, and unpicks the apparent (or presumed) uniformity of this fabric across the island (Bruno 2009: 112). Also, Bruno and Capelli suggest a link between the VQ fabric and some votive plates from Tas-Silġ, which Bruno believes are also made in a similar volcanic-quartz fabric (Bruno 2009: 108). Further macroscopic and scientific analysis are planned of coarse ware vessel fabrics from the University of Malta’s excavations at Tas-Silġ, which might offer an opportunity to tease out a more detailed extent of the source of tempering agents found in some Maltese vessels.

Amphorae [FRM08: 1 (50%); MLT84: 1 (50%)]

#### **Local Fabric 7**

This last fabric represents a rather common and generic coarse limey clay typical of all local handmade vessels (**Figure 23**). The colours range from pale pink, to pale brown, grey and even black. Mixed within the clay are large bits of lime, microforaminifera, microfossils and other mixed gritty inclusions associated with an unpurified clay source. Vessels are usually left unslipped, although at least one example had red and black painted surfaces (C19.2). This fabric is ubiquitous throughout history and unless surface treatments and shape are taken into consideration, it is difficult to determine the difference between prehistoric, Punic, Roman and Medieval fragments made in variants of this fabric (Blagg, Bonanno and Luttrell 1990: 66-68). More recently, attempts have been made to classify this fabric. Sagona classifies it as ‘Coarse pink-buff, hand-made ware’ (2015: 41-42) and ‘Hand-made coarse ware’ (2015: 71-72) for the Punic and Late Punic periods respectively. Bechtold’s MALTA-HP-1 fabric also belongs to a similar group, and was used in various handmade cooking forms in fourth-century BC contexts at the Żejtun villa (Schmidt and Bechtold 2013).

coarse wares [BLB12: 2 (25%); FRM08: 2 (25%); MLT84: 4 (50%)]

cooking wares [BLB12: 285 (80.5%); FRM08 11 (3.1%); MLT84: 58 (16.4%)]

# Catalogue of pottery

## Catalogue structure

The following catalogue is intended to display a wide range of pottery fragments from three different sites in Malta and Gozo. Each site was active during different periods of the Roman era, although some overlap is evident. The aim of this exercise was to detail important new and existing local and imported forms obtained from good Roman-period archaeological contexts as no comprehensive Roman pottery assemblages have ever been catalogued for the Maltese islands to date. The catalogue is directly reproduced from my DPhil dissertation (Anastasi 2015), however, the original numbering system has been changed to follow a simpler system using letters to denote the general class divisions (i.e. A=amphorae, B=fine wares, C=cooking wares, D=coarse wares, M=miscellaneous, L=lamps) followed by a consecutive number that lists the types recorded (A1, A2 etc.). This is then followed by an additional number, which lists the specific example recorded for the catalogue (A1.1, A2.1 etc.).

The material has been divided into four main groups: amphorae, fine wares, cooking wares and coarse wares. Within each group, the representative fragments were further divided according to logical criteria such as general source (imported or local), provenance (North Africa, Italian etc.) and most importantly shape (bowl, jug, amphora etc.). The criteria within each section were however adjusted to take into consideration typological distinctions that are more apparent in one group rather than another. **Appendix 1** is a concordance list of the original numbering system featuring in the DPhil against the new one presented below. This has been included here in order to ensure that existing references using the earlier system can be tallied with this new system.

Each catalogue entry follows with a general description of the type, followed by any general local and foreign parallels, and any dating evidence available. A list of representative examples then follows with fabric and surface details, context information and any additional features that characterise that particular sherd. All measurements are taken in centimetres (cm). Where necessary additional comments, type information, references and dates are included within an entry.

The catalogue is supplemented by **Appendix 2**, which presents the quantified data pertaining to each type from all the assemblages. The data are presented in a series of tables (amphorae, fine wares, cooking wares and coarse wares), which have been organised in a manner that distinguishes between each assemblage and the various phases within each.

The material was divided according to the types listed within the catalogue, and have been further divided into assemblage (i.e. Bulebel, Foreman Str. etc.), phases, and total number of fragments (rims, bases, handles and sherds) and the minimum number of individuals (MNI). Fragments which could not be classified according to a specific type were classed under more general categories found after the most specific types are listed. Pottery that came from mixed contexts was not included in the quantification tables found in **Appendix 2**. However, some representative examples were included in the catalogue when it was deemed necessary to document a specific form.

## Amphorae (A1-A24)

The amphora is a vessel one typically expects to find in any Classical-period Mediterranean assemblage. The tradition of Maltese amphorae stems from the Phoenician-Punic period, characterized by an ovoid body with a short opening and two vertically attached strap handles. By the early Roman period, a new form developed and took on a clearly Greco-Roman form comprising a troncoconic body that tapers into a pointed base or toe, with a clearly defined neck and shoulders, and two long sturdy strap handles attached from the opening and resting on the shoulder. Only a handful of locally produced amphora sherds were identified from the assemblages studied, which could be divided into four distinct and recognizable types already defined by Sagona (2002) and Bruno (2009).

### *Punic-period amphora forms (A1)*

#### **A1. Sagona amphora forms IV-V:1/IV:1 (Figure 24)**

The earliest types attested belong to Punic-period forms (A1) similar to those classified by Sagona from the funerary contexts across the Maltese islands, where she highlighted the morphological changes that affected the body and rim from Phases I to V (c. 800-100 BC) (Sagona 2002: 87-93). The majority of fragments identified in this assemblage were collared rims (A1.1-4), which find parallels with Sagona's amphora form IV-V: 1 or Ramon's form T-3.2.1.2, dateable to the late second/early first century BC to the first half of the first century AD (Sagona 2002: 92-93, figs. 347.1 and 348.1; Ramon 1995: 183). A single beaded amphora rim (A1.5), which found parallels with Sagona's amphora form IV: 1 and Ramon Torres' T-2.2.1.2 could be dated to the third-first century BC (Sagona 2002: 90-91, fig. 346.1). The dates ascribed to these two amphora types hail from comparisons with those discovered from tomb contexts. All of the examples recovered from the assemblage were also formed using Local Fabric

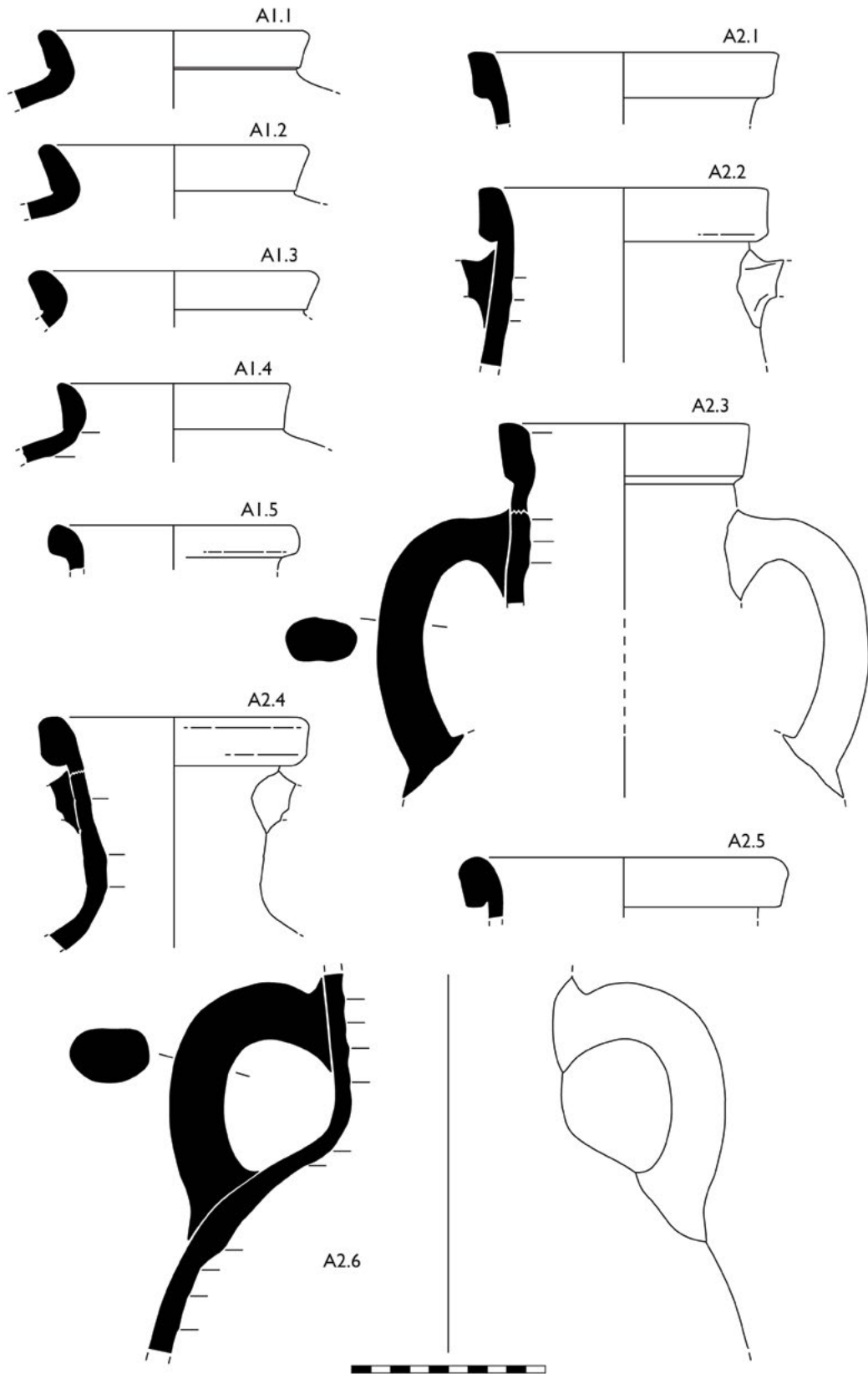

Figure 24: Local Punic and Roman amphorae (A1-A2).

1. The nature of the contexts did not provide any new dating evidence, which suggests that these forms were residual fragments in the later-dated Melita esplanade phases (Phase 4).

That these forms are considered local products is supported by the fabric (Local Fabric 1), which is shared with the vast majority of plain ware vessels that were found associated with these amphorae in Punic rock-cut tombs across the islands. In addition, a defective example, also originating from a tomb context, which experienced severe blistering during the firing process, also suggests a local provenance (Bruno 2002: 100, fig. 15). These Late Punic forms belong to a general series, which were produced in several areas throughout the central Mediterranean, including Western Sicily and North Africa (Anastasi 2015: 156-164; Anastasi 2018). Local Maltese examples were also occasionally exported overseas as witnessed by the discovery of specimens in Maltese fabrics in Pantelleria (Bechtold 2013: 467), Velia (Gassner and Trapichler 2010: 167, fig. 112; Bechtold 2013: 467), Mozia (Ciasca 1985: 18-19, fig. 1), Carthage (Delattre 1904: 8, fig. 5; Docter and Bechtold 2010, tab. 4), Sabratha (Dore 1989: 35-36, fig. 11.180-193, type 10) and Berenice (Riley 1979: 143, D91, fig. 72.91). Indeed, the discovery of earlier-dated forms suggest the continuation of a small export of local amphora-borne goods from as early as the seventh century BC (Anastasi 2015: 156-164, table 11; see also the recent contribution in Bechtold 2018). A number of seventh-century-BC amphorae from a shipwreck discovered off the coast of western Gozo, and which are thought to be made of Maltese clays, also supports this (Drap *et al.* 2015: 30353; Gambin and Woods 2017).<sup>5</sup>

Unfortunately, the nature of the contexts studied does not allow any additional comment on the dates given to these Punic amphora forms. They were only recovered from the Phases 1-2 from Bulebel, and as residual fragments in Phases 1-5 at the Melita Esplanade. None were recovered from the second-third century context in Gozo.

A1.1. BLB12/23/3: Rim, d. 14. Local Fabric 1: Hard-fired, coarse red clay with thick dark grey core with large yellow lime, fine foraminifera and occasional red ore grain inclusions; rough pale grey skin. Type: Sagona amphora form IV-V: 1. Date: c. 200 BC-AD 50. Context: Bulebel SU 23, Phase 2.

A1.2. BLB12/30/1: Rim, d. 14. Local Fabric 1 (**Figure 22**): Hard-fired, coarse orange clay with fine yellow lime and foraminifera inclusions; thin pale yellow/cream slip. Type: Sagona amphora form IV-V: 1. Date: c. 200 BC-AD 50. Context: Bulebel SU 30, Phase 2.

A1.3. BLB12/58/1: Rim, d. 15. Local Fabric 1: Hard-fired, coarse orange clay with lots of fine to medium yellow, and fine white foraminifera inclusions; thin, matt pale yellow/cream slip. Type: Sagona amphora form IV-V: 1. Date: c. 200 BC-AD 50. Context: Bulebel SU 58, Phase 1.

A1.4. MLT8426321: Rim, d. 12. Local Fabric 1: Pale orange clay with yellow lime and foraminifera inclusions; pale yellow/orange slip/skin. Type: Sagona amphora form IV-V: 1. Date: c. 300 BC-AD 50. Context: Melita SU 1100, Phase 2.

A1.5. MLT8449355: Rim, d. 13. Local Fabric 1: Hard-fired pale orange clay with lime and foraminifera inclusions; unslipped. Type: Sagona amphora form IV: 1/Ramon T-2.2.1.2. Date: c. 300-100 BC. Context: SU 1093, Phase 4, residual.

#### **Roman-period amphora forms (A2-A4)**

Distinctly Roman-period amphora forms appear in the archaeological record from the second century BC (**Figures 24 and 25**). Two forms, the Malta Types 1 (**A2**) and 2 (**A3**), were formally classified by Bruno in a study on Maltese amphorae in the Roman and Byzantine periods (Bruno 2002; 2004; 2009).

#### **A2. Malta type 1 (Figures 24 and 25)**

Compared with the traditional Punic form discussed above, this new tradition shares typological features with the Ancient Tripolitanian and Dressel 26 form, characterized by a squat ovoid body tapering into a short peg, a distinct shoulder and neck with a collared rim, and two vertical strap handles attached to the rim and shoulder. Bruno described the new morphology of the Malta type 1 as a break from the local Punic tradition, which adopts typological features that are more akin to Republican-period amphorae (Bruno 2009: 102). Compared to the Punic forms, the Malta type 1 gains a distinct neck and elongated body, which tapers into a short peg or toe (**A2.7** and **A2.8**). Two handles are attached under the rim to the shoulder (**A2.3** and **A2.6**). Two rim variants were identified in these assemblages. One is a tall collared rim with a

<sup>5</sup> The first results of thin-section analyses of the amphorae retrieved from the Phoenician shipwreck have been concluded, and will shortly be submitted for publication.

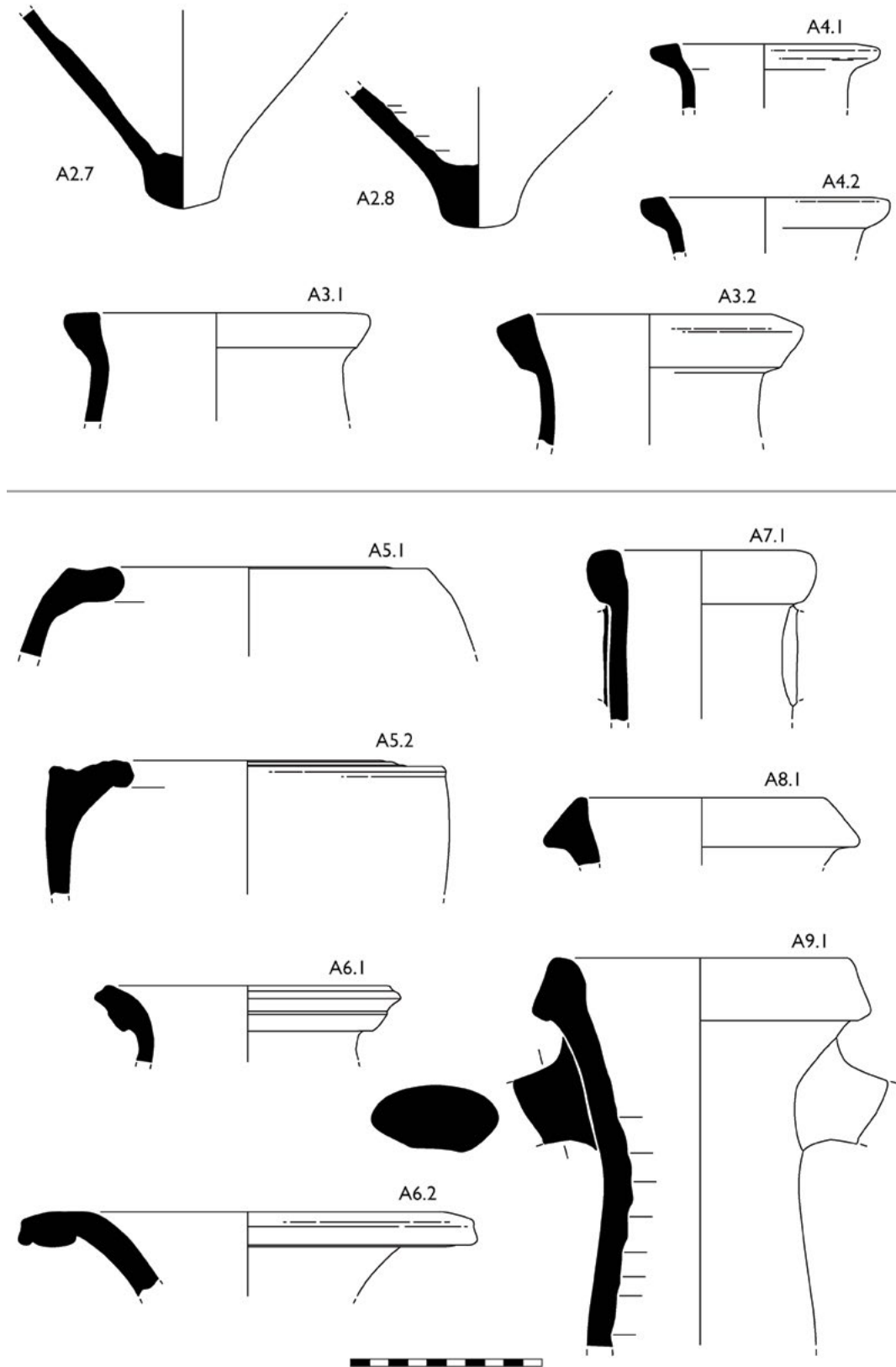

Figure 25: Local and imported Punic and early Roman amphorae (A2-A9).

rectangular section (A2.1-3), whilst the other is shorter and somewhat thicker (A2.4-5). A Late Republican date (c. the beginning of the second to the late first century BC) was assigned to this form by Bruno on the basis on the assemblages she studied at the sanctuary at Tas-Silġ and the Roman farm at San Pawl Milqi. The latter site also suggested a function as an olive oil amphora on account of the olive presses and *trapeta* that were discovered (Bruno 2009: 104-105). Both Local Fabrics 1 and 2 are associated with the Malta type 1.

A2.1. BLB12/32/35: Rim, d. 16. Local Fabric 2: Grainy, yellow fabric with black glauconite and small red inclusions; pale green, possibly underfired surface. Context: Bulebel SU 32, Phase 2.

A2.2. BLB12/55/5: Rim and neck, d. 15. Local Fabric 2: Hard-fired, dark orange fabric with lots of fine black glauconite, fine yellow lime and foraminifera inclusions; thick, matt, pale yellow/cream slipped surface. Context: Bulebel SU 55, Phase 1.

A2.3. BLB12/55/6: Rim, neck and handle, d. 13. Local Fabric 1: Hard-fired, dark grey mixed with green-coloured clay (over-fired?) with thin pale orange edges with fine burnt foraminifera and lime inclusions; unslipped pale orange/pink skin. Context: Bulebel SU 55, Phase 1.

A2.4. BLB12/58/38: Rim and neck, d. 14. Local Fabric 2 (Figure 22): Hard orange fabric with lots of black glauconite, fine yellow lime and fine white foraminifera inclusions; thin pale yellow-slipped exterior surface. Context: Bulebel SU 58, Phase 1.

A2.5. MLT84/49943: Rim, d. 16. Local Fabric 1: Coarse pale orange clay with lime and foraminifera inclusions; pale cream-brown slip. Context: Melita SU 1098, Phase 5; residual.

A2.6. BLB12/55/3: Neck, handle and shoulder. Local Fabric 1: Pale orange/pink clay with large yellow lime, fine white foraminifera and darker red grog inclusions; thick pale yellow/cream slipped surfaces; thick, oval-section handle. Context: Bulebel SUs 55 and 54 (vessel composed of six joining fragments within two contexts), Phase 1.

A2.7. BLB12/55/4: Peg, Local Fabric 2: Hard-fired, pale orange clay with fine and large yellow lime, foraminifera and some fine black glauconite inclusions; unslipped pale pink/orange surface. Context: Bulebel SU 55, Phase 1.

A2.8. MLT84/26339: Peg, Local Fabric 1? Soft pale brown fabric with lime and foraminifera inclusions; unslipped. Context: Melita SU 1100, Phase 2; most probably residual in this context.

### A3. Malta type 2 (Figure 25)

A second Malta type (A3) is associated with an early Imperial date and, according to Bruno, developed from the Malta type 1. Many variants differing in shape and size were identified by Bruno. However, she noted that all the rims were generally consistent and were 'flared square-collared [...], flat on top, and often with a sea-urchin [*ad echino*] profile' (Bruno 2009: 105), or more simply they resembled the *echinus* architectural moulding – flat on top with a sloping profile. The body is squat and in piriform shape, tapering into a short and hollow button toe. Only two examples (A3.1-2) of this type were identified in the three assemblages (one from Gozo, and a second from a phase-5 context at the Melita Esplanade). Their absence from any of the Bulebel contexts does support Bruno's suggestion that this form dates to the first two centuries AD, and possibly later, however, too few are known to suggest any further conclusions.

Bruno associated this form with a chemically isolated fabric, Group VQ (Local Fabric 6) that contains black volcanic inclusions within a typically lime-rich local clay (Bruno 2009: 110). Both rims from the assemblage (A3.1-2) was made in a similar fabric. As discussed above, the source of the black volcanic content in Local Fabric 6 is not local to the Maltese Islands, but the typological features of the form and the fact that no similar amphorae of this kind are known outside of the Maltese Islands suggest that this is a local product made using local clay and imported temper (Bruno 2009: 110-111; Bonanno 2007: 522). It remains unclear whether A3.2 is contemporary with the latest forms in the Melita Esplanade context (mid-third to mid-late fourth century AD), and too few were identified to contribute any further chronological details for the form.

A3.1. FRM08/42/87: Rim, d. 16. Local Fabric 6 (Figure 23): Hard-fired pale yellow/orange fabric with lots of fine to large yellow lime, fine white foraminifera, red and black glauconite and augite<sup>6</sup> inclusions; pale grey/cream-slipped surface. Context: Foreman Street SU 42.

A3.2. MLT84/49991: Rim, d. 18. Local Fabric 6: Hard dark orange clay with fine white lime, angular gypsum/quartz (?) and fine black volcanic inclusions. Context: Melita SU 1097, Phase 5.

### A4. Malta type 3 (Figure 25)

A third form, included here as Malta type 3 (A4) for consistency, was recorded based on two rim fragments

<sup>6</sup> The augite compound in this sample was confirmed by Ascjak's study (2018: 126). In the original study, this sherd's fabric was recognised as Local Fabric 2, but has been subsequently changed to reflect the new findings (Anastasi 2015: 377).



found in the assemblage and is characterized as a seemingly smaller version of the Malta type 2. The *echinus* rim is distinct, and both shared the Local Fabric 2 clay (A4.1 and A4.2). No complete profiles or any associated handles or bases were identified that can be tied to this form, making further comparisons and finding a date difficult. However, they are probably contemporary with the Malta type 2 in that they both originated from similarly dated contexts.

A4.1. MLT84/49325: Rim, d. 12. Local Fabric 2: Hard pale red fabric with lime and black glauconite inclusions; unslipped. Context: Melita SU 1084, Phase 4.

A4.2. MLT84/49884: Rim, d. 13. Local Fabric 2: Hard pale orange fabric with fine lime and black glauconite inclusions. Context: Melita SU1085, Phase 3.

### **Imported amphorae (A5-A24)**

The following section includes a detailed list of the types of imported amphora fragments that were identified in the three assemblages. Many of the fragments are divided into general groups based on shared similarities. A description of each sherd is provided after a general description of the type in question.

#### **A5. Imported Punic amphorae: Ramon type 5 (Figure 25)**

These large torpedo-shaped amphorae are very common on coastal sites throughout the Punic western and central Mediterranean from about the fourth to third century BC. Major production centres of a wide variety of variants have been identified in North Tunisia, in particular the Carthage area, and the southern coast of Spain. With the exception of the San Pawl Milqi villa, where Bruno says Sabratha types 3 and 4 were imported in 'significant quantities' (2009: 172), examples from other local contexts are not common, when compared with Punic-period assemblages in the central Mediterranean. The recent study of the material from the University of Malta's excavations at the sanctuary of Tas-Silġ and the Żejtun villa did not yield any significant quantities of imported Punic forms (Sagona 2015: 78-79; pers. comm. Babette Bechtold). Individual examples come from tomb contexts, in particular when used as sarcophagi like the child burial from Tal-Virtù (MAR 1968: 6-7; Sagona 2002, burial no. 625), or private collection (Sagona 2002, fig. 317.4). Certainly more examples exist, but remain unpublished. The examples listed here are few (only two) and are also residual fragments.

A5.1. MLT84/49944: Rim, d. 13 (internal). Fabric: Pale orange fabric with fine quartz inclusions; cream salt-slipped surface. Source: North Tunisia. Type: Similar to Ramon type T-4.2.1.5 or T-5.2.3.2/Sabratha type

4. Date: mid-fourth-mid-third century BC or mid-third-early second century BC respectively. Context: Melita SU 1098, Phase 5; residual.

A5.2. MLT84/26244: Rim, d. 12 (internal). Fabric: Hard-fired pink clay with lots of fine rounded quartz inclusions; pale yellow/cream slipped surface. Source: Carthage area, North Tunisia. Type: Similar to Ramon type T-5.3.3.1/Sabratha type 4. Date: fourth/third century BC. Context: Melita SU 1099, Phase 5; residual.

#### **A6. Imported Punic amphorae: Ramon type 7 (Figure 25)**

This general group belongs to a second, slightly later, common Punic form widely distributed throughout the central and western Mediterranean from about the third century BC until at least the early first century BC (for an overview of the forms see Ramon 1995: 205-216, types T-7.2.1.1-7.5.2.3; Martin-Kilcher 1999; Bonifay 2004: 89-90). Production centres are common in North Africa, southern Spain and western Sicily. This form is more common on the Maltese islands than the earlier imported Punic form (A5), although, again, the proportion of vessels never reaches any relatively significant range when compared with other central Mediterranean sites for the period. North African examples have been identified at the Żejtun villa (Anastasi 2010: 293, fig. 129.14), San Pawl Milqi and Tas-Silġ (Bruno 2009: 175-176, figs 36.8-12). In addition, a number of examples have been recovered from the seabed off the coast of Xlendi Bay, Gozo, thought to have originally formed part of a heterogeneous cargo identified in 1961 (Azzopardi 2013: 288-289), some of which are on display at the National Museum of Archaeology in Victoria, Gozo.

A6.1. BLB12/14/3: Rim, d. 16. Fabric: Hard-fired, gritty red clay with abundant fine round quartz, some fine white lime and occasional black inclusions; pale yellow skin. Source: North/Central Tunisia. Type: Martin-Kilcher type B2/Ramon T-7.2.1.1. Date: mid-second to first century BC. Context: Bulebel SU 14, Phase Q2, mixed context.

A6.2. MLT84/26320: Rim, d. 24. Fabric: Pink/pale red clay with fine round quartz inclusions; cream-coloured exterior surfaces. Source: North Tunisia. Type: Martin-Kilcher type A/Ramon T-7.4.2.1. Date: c. second century BC (Martin-Kilcher 1999: 416-417). Context: Melita SU 1100, Phase 2, residual.

#### **A7. Western Greek amphora (Figure 25)**

This category is reserved for an imported fourth-second-century-BC amphora typical of western Greek (mainly Greek Sicilian) and Aegean centres. Forms such as this

are often found in assemblages also containing North African Punic amphorae and like the imported Punic forms, Greek amphorae have been found on Malta but in small numbers (Bruno 2009: 171-172). A handful of similar examples were discovered in the assemblages from the University of Malta's excavations at Tas-Silġ (Sagona 2015, figs 1:133.7, 8; 1:134.1, 3-4), where a more detailed assessment of these Greek forms has recently been published (Bechtold 2018).

A7.1. MLT84/26271: Rim, d. 12. Fabric: Hard red/brown fabric with mica and occasional, large black volcanic inclusions; unslipped. Source: Imported; Southern Italy/Sicily? Type: Gassner 'Randform' 3/'greco-occidentale 1' (Polizzi 1997: 99, fig. 5.7; Bechtold 2012, pl. 5 no. 5.7; Gassner 2003). Date: c. fourth-second century BC. Context: Melita SU 1099, Phase 5, residual.

### A8. Greco-Italic forms (Figure 25)

Several studies detailing the form, chronology and distribution of this Early Republican amphora are available (see Will 1982; and relevant references in Peacock and Williams 1986 and Keay and Williams 2005 [2014]). The single example found in the Bulebel Phase 1 assemblage is Campanian in origin and probably belongs to the D series classified by E. Will who dated it to the first half of the second century BC (Will 1982: 356). Like the previous forms, these amphorae are also found on Maltese sites but in small numbers (Bruno 2009: 173).

A8.1. BLB12/32/30: Rim, d. 12 Fabric: Campanian black sand. Source: Campania. Type: Greco-Italic form D? Date: early first century BC. Context: Bulebel SU 32, Phase 1.

### A9. Dressel 1 (Figures 25 and 26)

This form is synonymous with the apex of the Late Republican Italian wine trade, represented by an unprecedentedly wide distribution of mass produced containers found in large volumes across the Mediterranean region and beyond, from the second century BC (Laubenheimer 2013: 99-103; see Keay and Williams 2005 [2014] for a broad overview of the form). A relatively large number of these containers were imported to the Maltese islands and are always well represented in local assemblages (for Tas-Silġ and San Pawl Milqi see Bruno 2009: 173; for Rabat, Malta see Antico Gallina 2004; for Żejtun see Anastasi 2010, fig. 129. 10). A wide range of fabrics, most of which are from southern Italian sources, have been identified within the assemblages studied. Campanian black-sand fabrics are the most common, however, some Adriatic (A9.1) and Spanish (A9.2) sources are also possible.

A9.1. BLB12/58/50: Rim, neck and handle, d. 16. Fabric: Fine pale brown fabric with small brown and red inclusions; unslipped. Source: Adriatic coast? Type: Dressel 1A. Date: Mid-second to mid-first century BC. Context: Bulebel, SU 58, Phase 1.

A9.2. BLB12/58/21: Rim, d. 14. Fabric: Dark pale orange/brown clay with mica, irregular large quartz and white and grey inclusions; unslipped. Source: Imported, possibly Spanish? Type: Dressel 1A. Date: Mid-second to mid-first century BC? Context: Bulebel SU 58, Phase 1.

A9.3. BLB12/58/46: Rim, d. 16. Fabric: Campanian black sand. Source: Campania. Type: Dressel 1A. Date: Mid-second to mid-first century BC. Context: Bulebel SU 58, Phase 1.

A9.4. BLB12/58/18: Rim, d. 14. Fabric: Campanian black sand. Source: Campania. Type: Dressel 1A. Date: Mid-second to mid-first century BC. Context: Bulebel, SU 58, Phase 1.

A9.5. BLB12/40/4: Rim, d. 20. Fabric: Pale red fabric with black sand and yellow lime inclusions. Source: Campania. Type: Dressel 1C. Date: Late second early first century BC. Context: Bulebel SU 40, Phase 2.

A9.6. BLB12/32/46: Shoulder, d. 30 (widest internal diameter). Fabric: Pale red to grey hard fabric with black sand, quartz and white lime inclusions. Source: Campania? Type: Dressel 1? Context: Bulebel SU 32, Phase 2.

### A10. Lamboglia 2 (Figures 26 and 27)

This Adriatic form is also a very common early Roman container that was also widely diffused across the Mediterranean from the second to late first century BC. The form is found on most Maltese sites too (Bruno 2009: 175).

A10.1. BLB12/40/3: Rim, d. 18. Fabric: Fine pale brown/pink fabric with mica and fine black inclusions. Source: Adriatic? Date: second-late first century BC. Context: Bulebel SU 40, Phase 2.

A10.2. BLB12/32/7: Rim, d. 18. Fabric: Fine, buff fabric with mica, white and black inclusions; there is a faint and illegible stamp on the rim (Figure 27). Source: Adriatic. Date: second-late first century BC. Context: Bulebel SU 32, Phase 2.

A10.3. BLB12/32/49: Rim, neck and handle, d. 18. Fabric: Fine cream fabric with quartz, red and fine black inclusions. Source: Adriatic. Date: second-late first century BC. Context: Bulebel SU 32, Phase 1.

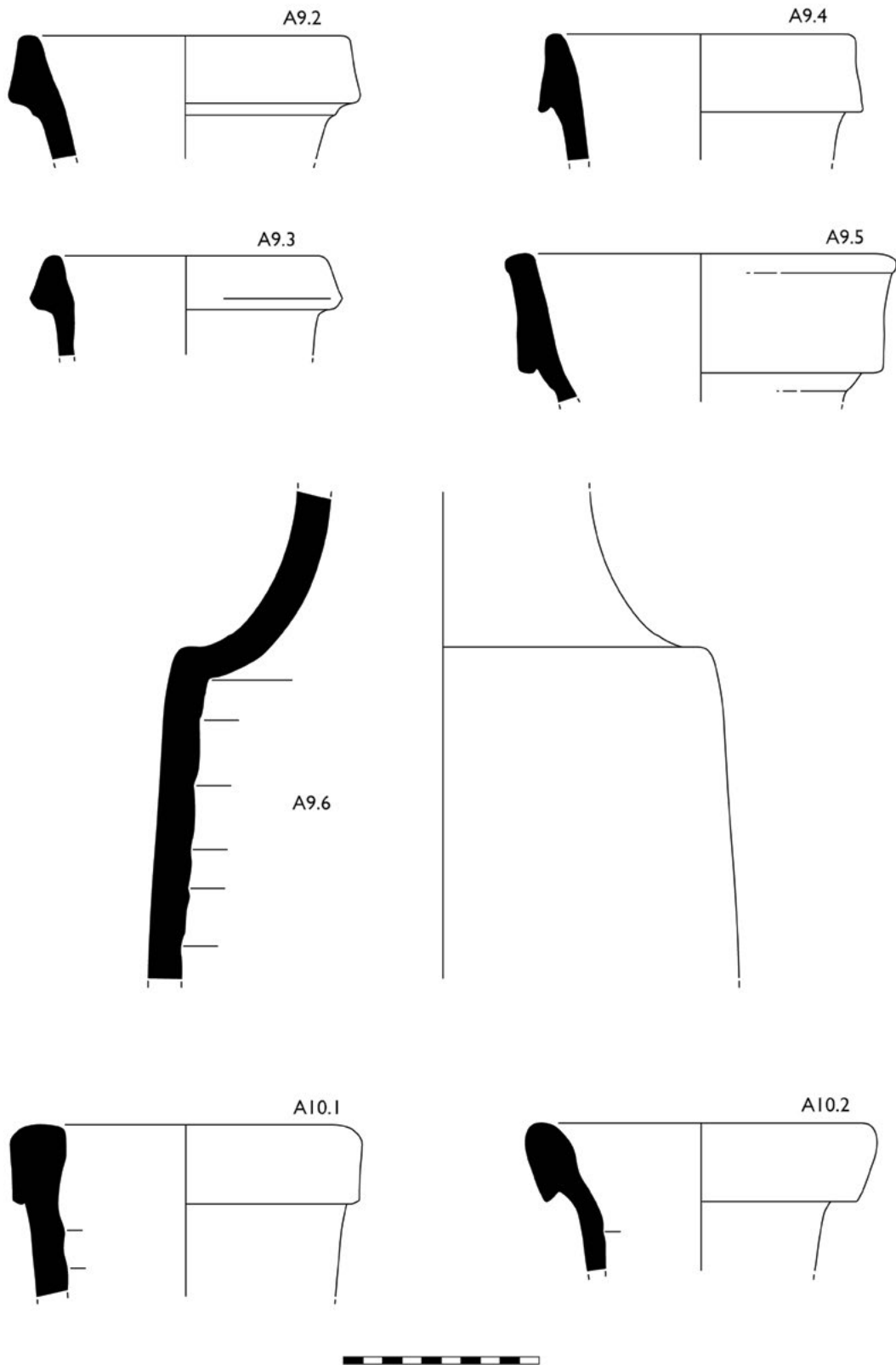

Figure 26: Imported early Roman amphorae (A9-A10).



Figure 27: Detail of possible stamp on an imported Lamboglia 2 amphora (A10.2) from Bulebel.

#### A11. Dressel 2-4 (Figures 28 and 29)

The Dressel 2-4 amphora is the latest in the range of common and widely diffused Italian wine containers exported in huge quantities after the end of the Third Punic war (see Keay and Williams 2005 [2014] for a broad overview of this form). The characteristic double-cordon strap handles make identification of this, and related forms, relatively straightforward. Campanian Dressel 2-4 amphorae are the most common on Maltese sites, but a handful of other sources have also been identified (Bruno 2009: 177).

A11.1. BLB12/32/29: Neck and handles. Fabric: Campanian black sand. Source: Campania. Date: mid-first century BC to end of the first century AD. Context: Bulebel, SU 32, Phase 1.

A11.2. BLB12/65/1: Rim, neck and handles, d. 14. Fabric: Pale orange fabric with round grey, red grains and white inclusions and fine gold mica; unslipped cream skin. Source: Imported, possibly Spain? Crete? Date: Mid-first century BC to end first century AD? Context: Bulebel SU 65, Phase 2.

A11.3. MLT84/26357: Rim, neck and handles, d. 12. Fabric: Hard, pale pink fabric with large red and black (not volcanic) angular grog or stone inclusions, and white lime inclusions; cream/pale pink slipped exterior. Source: Imported. Date: Mid-first century BC to end first century AD? Context: Melita SU 1100 and 1086, Phase 2.

#### A12. Sicilian MRA1b (Figure 30)

This flat-bottomed ‘table amphora’ is characterised by a wide, troncoconic body with a tall, narrow, ribbed neck culminating into a thick-lipped rim. Two loosely ribbed handles are attached to the neck and shoulder, and the body sits on a narrow ring base. Up until quite recently these amphorae were believed to be North African in production, mainly on account of the similarity in fabrics, but also the distribution patterns that showed large concentrations in Cyrenaica, Tunisia and Tripolitania (Riley 1979: 177-179). More recently, petrographic analysis has shown that many of these amphorae (and the later variants, MRA1a) were manufactured in Sicily for the storage and transport of Sicilian wine (Franco 2014; Bonifay *et al.* 2013: 114-116). North African variants of this form do exist alongside the Sicilian productions, however, in smaller numbers and with a more limited distribution, which is mostly restricted to North African cities (Franco 2014: 252; Bonifay 2016: 517). On the other hand, Sicilian amphorae have a wide and sometimes dense distribution around the western, central and eastern Mediterranean and attest to a strong Sicilian export trade in wine, alongside that of grain. Sicilian MRA1b amphorae are quite common in the Maltese islands and have been found in tomb contexts as well as both rural and urban excavations, for instance at San Pawl Milqi and Tas-Silġ (Bruno 2009: 176-177), Żejtun (Anastasi 2010, fig. 130.7), Hal Millieri (Bonanno, Blagg and Luttrell 1990: 63, fig. 15.84-86) and Għar ix-Xiħ, Gozo (Anastasi and Quercia 2008-2009). All the examples of this form from the Bulebel and Melita assemblages originated from workshops in the Catania region, which have recently been included in a more detailed

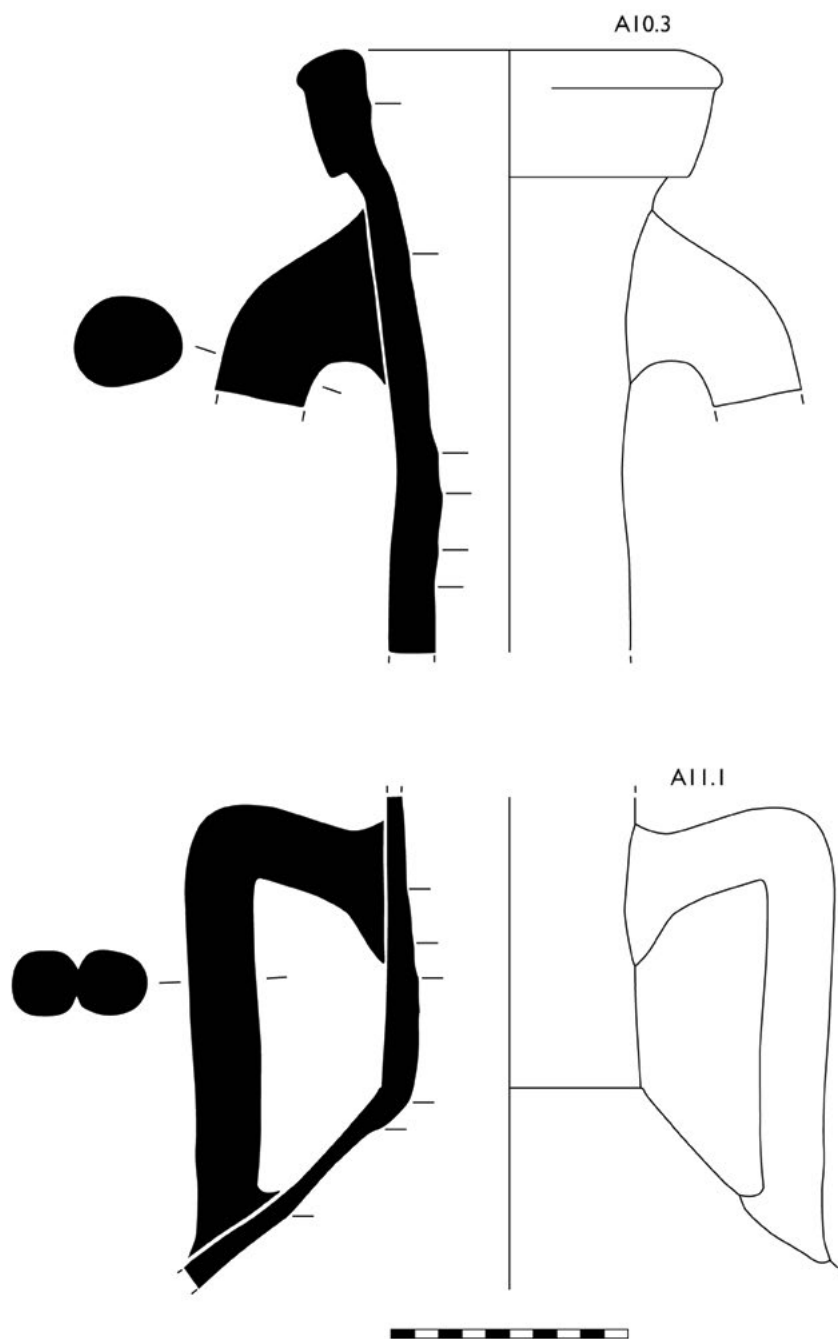

Figure 28: Imported amphorae (A10-A11).

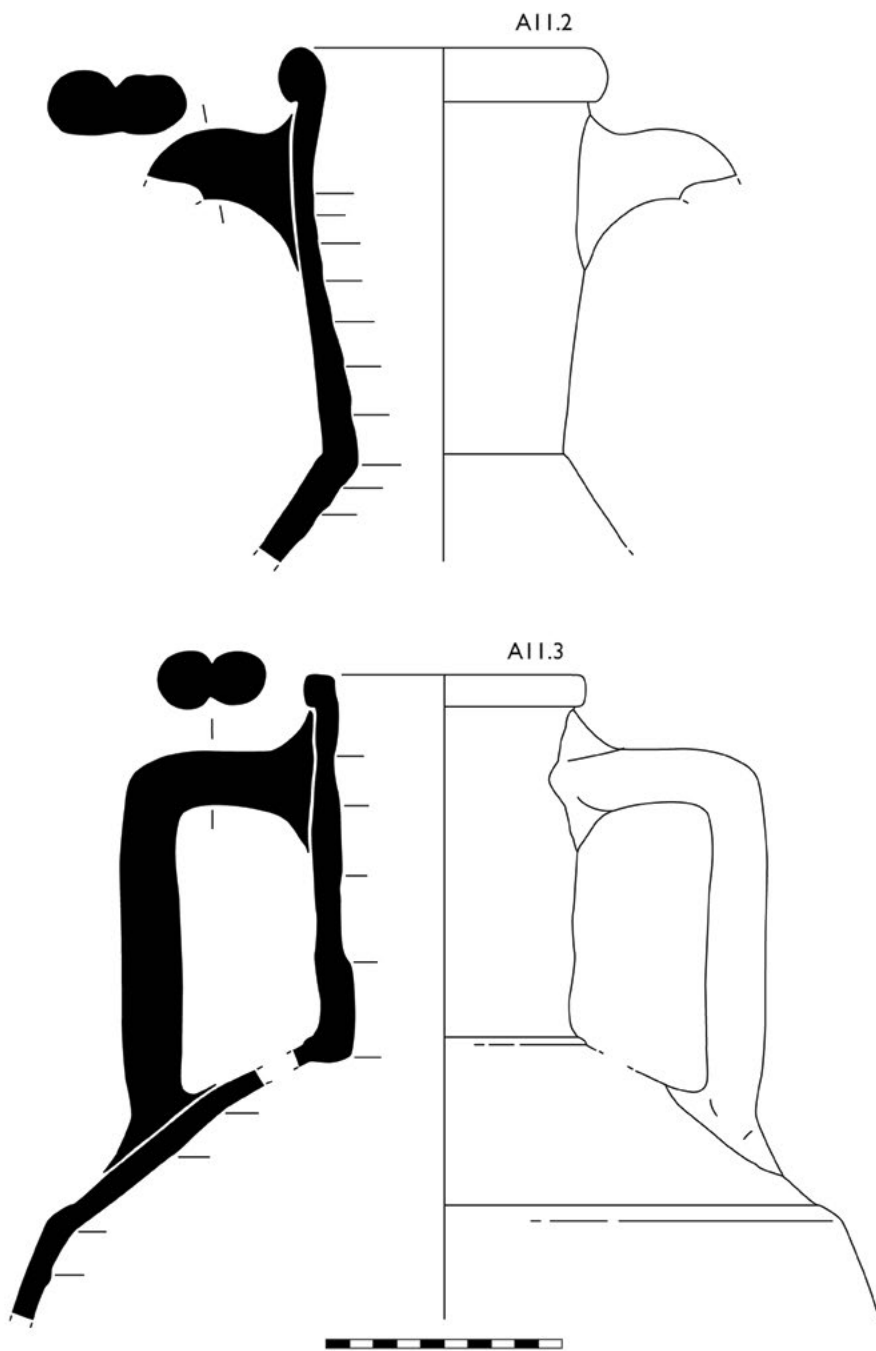

Figure 29: Imported amphora (A11).

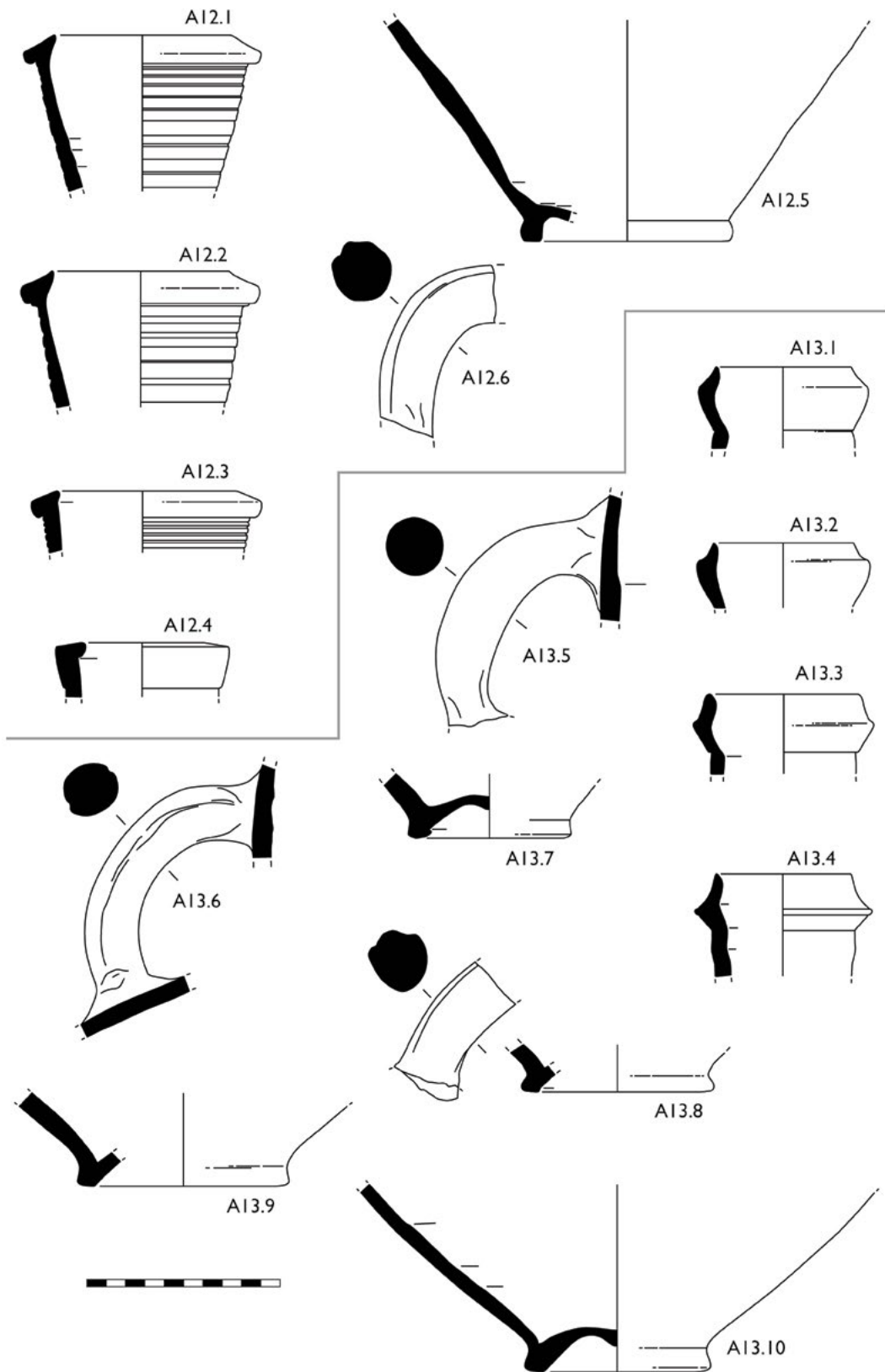

Figure 30: Imported east Sicilian amphorae (A12-A13).

typology as Catania Flat-Bottomed form 1 (pers. comm. Carmela Franco; Franco 2014: 227-229). One example (A12.4) was identified by Franco as a possible Naxos Early Roman type from the Naxos area of eastern Sicily, but the identification remains uncertain (pers. comm. Carmela Franco).

A12.1. BLB12/24/13: Rim and ribbed neck, d. 9. Fabric: Fine brown fabric with fine quartz, red and white inclusions; pale brown exterior surface. Source: East Sicily, Catania. Type: Riley's Mid-Roman Amphora 1b (Riley 1979, no. 216) /Franco's Catania Flat-Bottomed form 1 (Franco 2014: 227-229). Date: Mid-first to mid-second century AD. Context: Bulebel SU 24, Phase 2.

A12.2. BLB12/32/27: Rim and ribbed neck, d. 9. Fabric: Hard orange/brown with fine quartz, lime and black inclusions; pale brown exterior surface. Source: East Sicily, Catania? Type: Riley's Mid-Roman Amphora 1b/Franco's Catania Flat-Bottomed form 1. Date: Mid-first to mid-second century AD. Context: Bulebel SU 32, Phase 2.

A12.3. MLT84/26569: Rim, d. 9. Fabric: Brown quartz clay with white lime and black volcanic inclusions; streaky pale brown/white skin; ribbed neck. Source: East Sicily. Type: Riley's Mid-Roman Amphora 1b/Franco's Catania Flat-Bottomed form 1. Date: mid-first to mid-second century AD. Context: Melita SU 1071, Phase 5, residual.

A12.4. BLB12/39/17: Rim, d. 9. Fabric: Orange quartz clay with fine grey, white and occasional black inclusions; streaky pale brown/white skin. Source: East Sicily, Naxos production? Type: Naxos Early Roman type/Early Roman Amphora 13 (Riley 1979: 172; pers. comm. Carmela Franco). Date: last quarter of the first century AD. Context: Bulebel SU 39, Phase 2.

A12.5. BLB12/23/8: Ring base, d. 11. Fabric: Hard, fine red/brown clay with fine black and white inclusions; surface of lower body covered with pale yellow 'dribbled' slip. Source: East Sicily, Catania production. Type: Mid-Roman Amphora 1b/Catania type 1 (Franco 2014). Date: Mid-first to mid-second century AD. Context: Bulebel SUs 23, 28 and 30, phase 2.

A12.6. MLT84/49607: Handle. Fabric: Red clay with dark grey/purple core with fine lime and black volcanic inclusions; grey, streaky skin; round, slightly ribbed handle section. Date: Mid-first to late second/early third century AD. Type: Ostia I, 453-454 (Panella 1968: 100, tav. XXVI, 453-454). Context: Melita SU 1109, Phase 5, residual?

A12.7. BLB12/24/14: Handle. Fabric: Pale brown fabric with lime, red and black inclusions that are quite large and spaced out; unslipped, ribbed, round-section handle. Source: East Sicily, Catania production. Type: Mid-Roman Amphora 1b. Date: Mid-first to mid-second century AD. Context: Bulebel SU 24, Phase 2 [not illustrated].

A12.8. BLB12/30/5: Handle. Fabric: Brown fabric with white lime, black volcanic inclusions and some mica; pale cream/brown skin; ribbed, round-section handle. Source: East Sicily, Catania production. Type: Mid-Roman Amphora 1b. Date: Mid-first to mid-second century AD. Context: Bulebel SU 30, Phase 2 [not illustrated].

A12.9. BLB12/39/18: Handle. Fabric: Dark brown/purple fabric with black volcanic and quartz inclusions; pale yellow slip. Source: East Sicily. Type: Mid-Roman Amphora 1b; Ostia II, 523. Date: first century AD. Context: Bulebel SU 39, Phase 2 [not illustrated].

A12.10. BLB12/14/2: Handle. Fabric: Fine, pale brown fabric with mica and black, dark red and fine white inclusions; unslipped, ribbed handle section. Source: East Sicily, Naxos production. Type: Mid Roman Amphora 1b. Date: Mid-first to mid-second century AD. Context: Bulebel SU 14, quarry 2 (Q2) [not illustrated].

### A13. Sicilian MRA 1a (Figure 30)

This form is morphologically similar to the earlier MRA 1b form except that the rim is cupped and biconical. The general form has a long history with slight morphological changes happening to the rim over the centuries (Bonifay *et al.* 2013: 114-116; Franco 2014: 233). A recent doctoral study by C. Franco, includes a revised chronological and morphological typology for this type of amphora, as well as a detailed petrographic study identifying the provenance of several variants to particular sites in Sicily (Franco 2014; Bonifay *et al.* 2013: 114-115). A clear morphological development in the ridged rims can be traced in examples from the Melita Esplanade (A13.1-4), which clearly show the characteristic ridges becoming more distinct and symmetrical. Like the previous Sicilian amphora form, this form was also thought to be a North African product, until recent petrographic analysis suggested a revision. All the Maltese examples were produced in the Catania region along Sicily's eastern coast and were imported to Malta in relatively high numbers (Anastasi 2016: 581, note 1778). One other recorded example includes one rim sherd, similar to A13.4, from the 1972 Żejtun villa excavations (Anastasi 2010, fig. 129.1). The examples identified in the Melita assemblage date to the late second/early third century to the early to mid-fourth century AD.



- A13.1. MLT84/49988: Rim, d. 6. Fabric: Fine pale brown clay with quartz, mica and black volcanic inclusions; unslipped. Source: East Sicily. Type: Mid Roman Amphora 1a/Franco variant 1. Date: Late second to mid-third century AD (AD 190-250?). Context: Melita SU 1097, Phase 5.
- A13.2. MLT84/49290: Rim, d. 7. Fabric: Gritty, orange fabric with quartz, round grey inclusions, lime and occasional black volcanic inclusions; thin, pale cream slip; small, heavily damaged rim fragment. Source: East Sicily. Type: Mid Roman Amphora 1a/Franco variant 1. Date: Late second to mid-third century AD (AD 190-250?). Context: Melita SU 1084, Phase 4.
- A13.3. MLT84/49720: Rim, d. 7. Fabric: Hard, red fabric with fine lime and black, volcanic inclusions; thin, white/cream skin. Source: East Sicily, Catania production. Type: Mid Roman Amphora 1a/Franco variant 2. Date: First half to end of the third century AD (AD 230/250-290). Context: Melita SU 1101, Phase 5.
- A13.4. MLT84/26116: Rim, d. 7. Fabric: Red quartz fabric with lime and black volcanic inclusions; pale cream exterior. Source: East Sicily, Catania production. Type: Mid Roman Amphora 1a/Franco variant 3. Date: Early to mid-fourth century AD (AD 310/320-360). Context: Melita SU 1096, Phase 5.
- A13.5. MLT84/25226: Handle. Fabric: Dark red/brown fabric with white lime, fine quartz, mica and black volcanic inclusions; pale cream skin; rim has been worn away; round section. Source: East Sicily, Catania production. Type: Mid Roman Amphora 1a/Ostia I, 453-454. Date: second-third century AD. Context: Melita SU 1071, Phase 5.
- A13.6. MLT84/49777: Handle. Fabric: Hard red quartz fabric with fine lime, mica and black volcanic inclusions; pale grey/cream slip; round section handle with two shallow grooves; slightly ribbed neck. Source: East Sicily, Catania production. Type: Mid Roman Amphora 1a/Ostia I, 453-454. Date: second-third century AD. Context: Melita SU 1105, Phase 5.
- A13.7. MLT84/49938: Ring base, d. 8. Fabric: Fine pale orange fabric with occasional large translucent quartz and some fine mica inclusions; pale yellow slip. Source: East Sicily. Type: Mid Roman Amphora 1a, late variant. Date: First half of the fourth century AD. Context: Melita SU1098, Phase 5.
- A13.8. MLT84/49361: Ring base and handle, d. 9. Fabric: Hard fine dark orange fabric with fine quartz, mica, fine white shell/lime and black volcanic inclusions; slightly ribbed round section handle; off-white thin slip on exterior surface with 'dribbled' thicker white slip on base exterior. Source: East Sicily, Catania production? Type: Mid Roman Amphora 1a/Ostia I, 453-454. Date: Mid-first to third century AD? Context: Melita SU 1093, Phase 4.
- A13.9. MLT84/23172: Ring base, d. 11. Fabric: Fine pale red/brown fabric with white lime, quartz and black volcanic inclusions; pale cream/brown skin. Source: East Sicily. Type: Mid Roman Amphora 1a. Date: Mid-first to third century AD? Context: Melita SU 1020.
- A13.10. MLT84/49255: Ring base, d. 11. Fabric: Hard orange fabric with fine lime, some mica, grey quartz and occasional black volcanic inclusions; Thicker cream 'dribbled' slip on a thin cream surface. Source: East Sicily. Type: Mid Roman Amphora 1a, variant 1 or 2 (like MLT84/49289 which is not illustrated). Date: Mid-first to third century AD? Context: Melita SU 1081, Phase 4.

#### A14. Crétoise 4/Dressel 43 (Figure 31)

Only a single rim fragment of this form was identified in all three assemblages, however, this type has a sporadic presence on some other Maltese and Gozitan sites (Bruno 2009: 178). This Cretan amphora, with its distinctive horned, round-sectioned handle is a common form well-diffused across the central and western Mediterranean, and has been dated from the early first to first half of the third century AD (Hayes 1983: 143).

- A14.1. BLB12/30/6: Rim with bulbous neck, d. 7. Fabric: Fine red/brown fabric with fine white and grey inclusions and some fine mica; yellow/cream exterior surface. Source: Crete. Type: Hayes 1983 fig. 21.21; Riley 1979, fig. 73.105. Date: Early first to first half of the third century AD. Context: Bulebel SU 30, Phase 2.

#### A15. Early Roman Amphora 12 (ERA 12) (Figure 31)

This form, first identified and classified by Riley in Berenice (Benghazi), is characterised by a short collared rim. Only one rim fragment was identified within the three Maltese assemblages and it appears to have a fabric that is similar to the one described by Riley, and which could be a local Benghazi fabric (1979: 168). To my knowledge no other fragments belonging to this form have been identified elsewhere on the archipelago, and their wider distribution remains unclear. This form is not common at Berenice or the rest of Cyrenaica (Riley 1979: 168). Based on the Berenice contexts, Riley found that this form first appears in the Augustan period and its presence peaks during the second half of the first century AD (Riley 1979: 168). The general dating of the Bulebel context does not contradict Riley's ascribed date.

A15.1. BLB12/39/14: Rim, d. 13. Fabric: Dark, rich brown fabric with fine red, grey and lime inclusions; unslipped. Source: Import, Benghazi, Cyrenaica? Type: Riley 1979, ERA 12, nos 168, 170. Date: Augustan to second half of the first century AD. Context: Bulebel SU 39, Phase 2.

#### A16. Crétoise 1 (AC 1)

This form is a relatively common Cretan wine amphora found throughout the central Mediterranean (Markoulaki *et al.* 1989: 554-566). Bruno recorded an increase in Aegean-sourced forms like this at Tas-Silġ and San Pawl Milqi in the early Imperial period (Bruno 2009: 178, fig. 38.5-6). A small number of handle fragments belonging to at least two vessels were recorded within the Melita assemblage. In addition to this, a recent discovery of a second/third-century AD necropolis within the St Paul's Catacomb complex, also in Rabat, Malta, contained a complete Cretan AC1 form, which had been reused as a coffin (pers. comm. David Cardona, July 2015). The arched, oval-section strap handles were assigned to this particular Cretan form with some doubt – larger and more diagnostic fragments would have been most welcome – but the distinctive fabric is clearly from a Cretan source.

A16.1. MLT84/49320: Handle. Fabric: Hard, fine, chalky dark orange fabric with fine lime, some mica and fine black inclusions; unslipped, oval strap handle. Source: Crete. Date: Early first to mid-third/fourth century AD? Context: Melita SU 1084, Phase 4 [not illustrated].

#### A17. Crétoise 2 (AC 2) (Figure 31)

This form is quite similar to the previous one (A16.1) in general shape, possible content and source, but the handles share morphological traits with Dressel 2-4 wine amphorae, which contain double-cordon handles. Like the AC 1 type, Bruno also recorded an unspecified number of these forms at Tas-Silġ and San Pawl Milqi (Bruno 2009: 178). Only two handle fragments were identified in the Melita assemblage in contexts dating to the mid-third/mid-fourth century AD (Phases 3-5).

A17.1. MLT84/49769: Handle. Fabric: Hard pale orange fabric with darker orange core, contains occasional large translucent, angular quartz grains, fine white, some black, and white shell (?) inclusions; rough, double-cordon, slightly peaked/horned strap handle; unslipped. Source: Crete. Date: Early first to beginning of the third century AD. Context: Melita SU 1105, Phase 5, residual?

A17.2. MLT84/49861: Handle. Fabric: Fine, pale orange/brown fabric with mixed fine red, grey and white inclusions with some fine mica; small double-cordon

handle that sits on shoulder; pale cream/white slipped exterior. Source: Crete. Date: Early first to beginning of the third century AD. Context: Melita SU 1085, Phase 3 [not illustrated].

#### A18. Uzita, 52, 10 (Figure 31)

This central Tunisian form is not commonly found outside Tunisia, but is attested in Tunisia itself (Sfax, El Jem, Rougga, Salakta, Uzita, Hergla and Carthage), Lampedusa, Sicily, Rome and Byllis, Albania (Bonifay 2004: 103, type 18, fig. 54). This form is believed to be a product of Salakta (*Sullechtum*), on the central Tunisian coast, on account of the fabric, and it is thought to have carried fish sauce. To date, no other fragments of this form have been recorded on Malta (Anastasi 2016, tab. CLXXXII).

A18.1. MLT84/49824: Rim, d. 16. Fabric: Hard, pale red fabric with quartz and lots of yellow 'salt halo' inclusions; grey/off-white-coloured skin (Peacock fabric 2.6). Source: Salakta/*Sullechtum*, central Tunisia. Type: Bonifay 2004: 103-105, type 18, fig. 54. Date: End of the first to second century AD. Context: Melita SU 1086, Phase 3.

#### A19. Africana IIA (Figure 31)

This classic African form belongs to the 'Africana grande' series, which is very common throughout much of the Mediterranean basin. It primarily carried wine or fish sauce to practically all coastal areas of the central Mediterranean from the end of the second to the mid-/end of the third century AD. Variants of this common form were produced along the north and central coast of Tunisia (Bonifay 2004: 111, fig. 57-58). Several examples have been identified in Maltese excavations (Anastasi 2016); including tomb contexts (Sagona 2002, fig. 259.31, Żejtun tomb [748]) and urban and rural settlements (Bruno 2009: 182).

A19.1. MLT84/49326: Rim, d. 14. Fabric: Hard red quartz fabric with a white salt-slipped skin (Peacock fabric 2.2). Source: North Tunisia/*Zeugitana*. Type: Bonifay amphora type 22. Date: End of the second to the end of the third century AD. Context: Melita SU 1084, Phase 4

A19.2. MLT84/49540: Rim, d. 15. Fabric: Coarse grey/brown fabric with quartz and lots of white inclusions (Peacock fabric 2.6). Source: Central Tunisia/*Byzacena*. Type: Bonifay amphora type 22. Date: End of the second to the end of the third century AD. Context: Melita SU 1110, Phase 5.

A19.3. MLT84/26270: Rim, d. 14. Fabric: Dark brick-red/black fabric with white lime/'salt halo' inclusions (Peacock fabric 2.6). Source: Central Tunisia/

*Byzacena*. Type: Bonifay amphora type 22. Date: End of the second to the end of the third century AD. Context: Melita SU 1099, Phase 5.

A19.4. BLB12/21/1: Body and peg. Fabric: Pale red fabric with quartz and fine white inclusions; white skin. Source: Salakta/*Sullechtum* (Central Tunisia). Date: End of the second to the end of the third century AD. Context: Bulebel SU 21, Phase 2.

#### A20. *Africana* IID [Bonifay's variant 1] (Figure 31)

This classic form, like the IIA form, belongs to the 'Africana grande' series and was widely diffused throughout the central and western Mediterranean from the second half of the third century. Production sites associated with this form have been identified along the north and central Tunisian coast (Bonifay 2004: 115-119, fig. 62a). Only one example was identified within this sample and has a fabric that would suggest it originated in central Tunisia. One other example, also from a central Tunisian production centre, was also identified within the Għar ix-Xiħ material on Gozo (Anastasi 2015: 136, fig. 17.2). In general, this amphora form is not common on the islands and does not appear to have been identified by Bruno within either of her samples at Tas-Silġ and San Pawl Milqi (Bruno 2009: 182-183). The only other recorded example comes from the excavation at Ta' Ġawhar 'tower' (Bruno 2009: 44, fn. 47)

A20.1. MLT84/49256: Rim, d. 11. Fabric: Pale red quartz fabric with lots of yellow lime 'salt halo' inclusions (Peacock fabric 2.6); white skin. Source: Central Tunisia. Date: Mid-third to first quarter of the fourth century AD. Context: Melita SU 1081, Phase 4.

#### A21. Tripolitanian 1 (Figure 31)

One amphora fragment was found belonging to this type from the Melita assemblage, and can be compared with the well-known Tripolitanian series produced in southern Tunisian and Tripolitanian centres, from about the first to third and early fourth century AD (Bonifay 2004: 90-92, fig. 47, amphora type 4). Amphorae of this type are known from Tas-Silġ and San Pawl Milqi, where only 'a modest number' have been recorded (Bruno 2004: 179). A further two examples were amongst the Roman-period pottery catalogued for the Hal Millieri excavations (Blagg, Bonanno and Luttrell 1990, fig. 15.87-88).

A21.1. MLT84/49990: Rim, d. 10. Fabric: Red/pink quartz fabric; white skin. Source: West Tripolitania? Type: Tripolitanian 1; only the rim profile survives so there is no way of knowing where the handles attached on the body. Date: first to early fourth century AD? Context: Melita SU 1097, Phase 5.

#### A22. Dressel 30 (Figure 31)

This amphora classification covers a wide range of variants of a North African ring-based table amphorae imitating the Gaulish Gauloise 4 form. These include Keay 1A and 1B (Keay 1984: 95-96; Bonifay 2004, forms 60-62; Panella 1973: 601-605). Most of the examples listed below are probably Mauritanian wine amphorae, however the fabrics from this region are not very well-known or clearly defined. Other red quartz fabrics are akin to North Tunisian production sites, whilst one example (A22.1) shares morphological and petrographical similarities with the Gauloise 2 amphorae produced in southern France, but further analysis needs to be done in order to confirm this. Bruno notes that only a 'minimal' number of examples were recorded at Tas-Silġ (Bruno 2009: 182, fig. 39.4), whilst one other rim recorded in the recent Belgo-Maltese survey in Malta in 2008 could belong to another example of this form (Docter *et al.* 2012: 136, fig. 29.46).

A22.1. MLT84/26261: Rim, d. 10. Fabric: Fine pale brown/beige fabric with fine mica, fine red and white inclusions and long black augite inclusions; unslipped. Source: Import, North Africa/Mauretania (Algeria)? Narbonne? Type: Dressel 30? Gauloise 2? Date: Second half of the first century BC to late second/early third century AD? Context: Melita SU 1099, Phase 5.

A22.2. MLT84/24832: Rim, d. 8. Fabric: Red quartz fabric with white skin. Source: North Tunisia. Type: Dressel 30. Date: third century AD? Context: Melita SU 1066, Phase 4.

A22.3. MLT84/49318: Handle. Fabric: Hard pale pink to cream fabric that contains large round quartz, lime and red inclusions; cream skin; U-shaped handle section. Source: Mauretania (Algeria)? Type: Dressel 30/Keay 1A. Date: third century AD. Context: Melita SU 1084, Phase 4.

A22.4. MLT84/49260: Handle. Fabric: Hard pale red quartz; cream skin (Dressel 30 fabric); U-shaped handle section. Source: North Tunisia. Type: Dressel 30/Keay 1A. Date: third-fourth century AD. Context: Melita SU 1081, Phase 4 [not illustrated].

A22.5. MLT84/49317: Handle. Fabric: Pale red fabric; white skin (Keay 1B fabric); U-shaped handle section. Source: North Africa. Type: Dressel 30/Keay 1B. Date: third-fourth century AD. Context: Melita SU 1084, Phase 4 [not illustrated].

#### A23. ERA 14? LRA 2? (Figure 31)

Only one example of this simple, cupped amphora rim was recovered from all the assemblages. No close

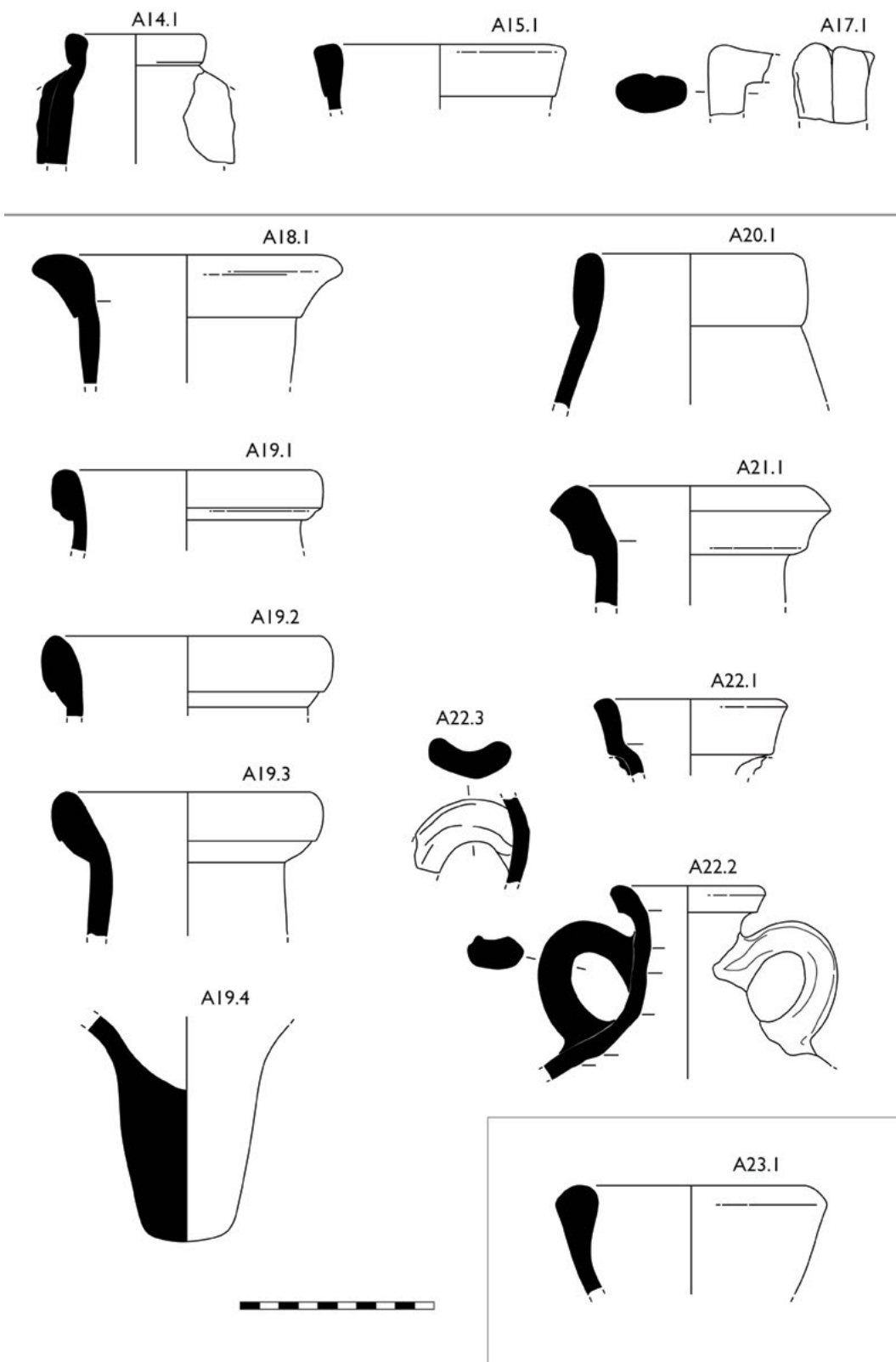

Figure 31: Imported amphorae (A14-A23).

parallels have been identified, however the profile resembles Riley’s Early Roman Amphora 14 (ERA 14), produced in Cyrenaica in about the second-third centuries AD (Riley 1979: 170-171, nos 175, 178, figs 78-79); or a Late Roman Amphora 2 (LRA 2) rim, common after the mid-fourth century AD (Riley 1979: 217-218, nos 348-349, figs 91-92). That this rim form might belong to variants of an eastern Dressel 24 type is also possible (Opait 2007, figs 2-3), however, the identification of this form remains open to speculation. The fabric is similar to that of other Cretan amphorae (see types **A16-A17**).

A23.1. MLT84/49713: Rim, d. 16. Fabric: Pale red/brown micaceous fabric with quartz, fine grey stone (?) and lime inclusions (Benghazi local fabric 5? or Cretan fabric?); unslipped pale brown surfaces. Source: Import. Context: Melita SU 1101, Phase 3.

**A24. Miscellaneous imported amphorae (Figure 32)**

This category includes a number of amphora examples which could not be classified with any degree of certainty, but were nevertheless included within this catalogue should a comparison be possible in the future.

A24.1. FRM08/57/28: Rim, d. 16. Fabric: Hard red quartz fabric with a white skin/slip (Peacock 2.2); very small fragment. Source: North Tunisia. Type: Unknown.

Date: second-third century AD? Context: Foreman Street SU 57.

A24.2. FRM08/57/26: Rim, d. 10. Fabric: Red quartz fabric with a white skin/slip (Peacock 2.2). Source: North Tunisia. Type: Unknown. Date: second-third century AD? Context: Foreman Street SU 57.

A24.3. FRM08/59/27: Rim, d. 11. Fabric: Red/brown quartz fabric (Peacock 2.1); unslipped. Source: North Tunisia. Type: Unknown. Date: second-third century AD. Context: Foreman Street SU 59.

A24.4. MLT84/49316: Rim, d.12. Fabric: Very gritty pink fabric with round quartz and lots of mixed sandy inclusions (Dressel 30 fabric?); cream skin. Source: North Africa, Algeria? Type: Dressel 30/Keay 1A? Date: third century AD? Context: Melita SU 1084, Phase 4.

A24.5. MLT84/49758: Rim, d. 15. Fabric: Gritty brown fabric with lots of large quartz inclusions, mica and occasional black and white inclusions; unslipped. Source: Import. Type: Unknown. Date: Unknown. Context: Melita SU 1105, Phase 5.

A24.6. MLT84/23210.4: Rim, d. 11. Fabric: Pale orange fabric with quartz, white, red and occasional black

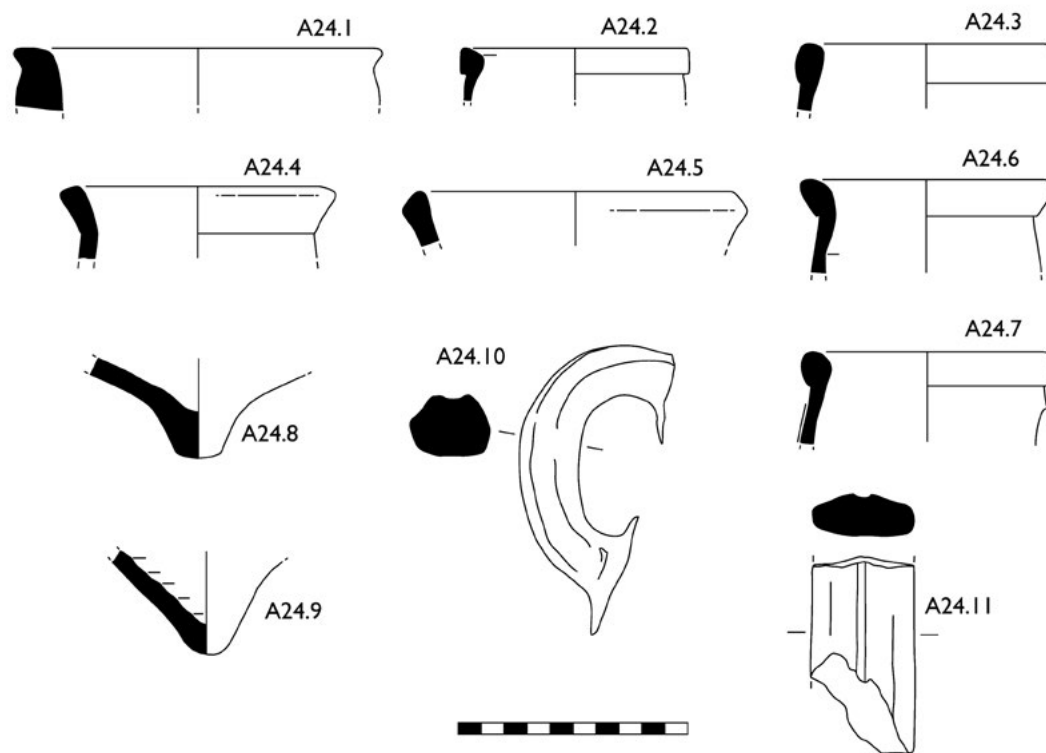

Figure 32: Miscellaneous imported amphorae (A24).

volcanic inclusions. Source: East Sicily? Type: East Palatine 1? Date: Beginning of the second century AD? Context: Melita SU 1024.

A24.7. MLT84/49862: Rim, d. 11. Fabric: Fine pale brown/beige fabric with fine quartz, mica and mixed white, red and grey inclusions; unslipped pale brown/beige surfaces; circular section handle scar 1cm below the rim. Source: Aegean? Rhodes? Type: Rhodian type? Date: Hellenistic/Roman period? Context: Melita SU 1085, Phase 3.

A24.7. BLB12/32/10: Small button peg. Fabric: Hard dark brown/red fabric with black inclusions. Source: Import. Type: Unknown. Date: Unknown. Context: Bulebel SU 32, Phase 2.

A24.9. BLB12/32/28: Small button peg. Fabric: Dark red/brown fabric with yellow lime, 'salt halos' and quartz inclusions (Peacock 2.6). Source: Central Tunisia. Type: Unknown. Date: Unknown. Context: Bulebel SU 32, Phase 2.

A24.10. MLT84/49362: Handle. Fabric: Hard pale red fabric with lots of fine quartz, larger angular quartz, black volcanic inclusions, white lime and red (iron ore?) inclusions; ridged strap handle; unslipped. Source: Import. Type: Unknown. Date: Unknown. Context: Melita SU 1093, Phase 4.

A24.11. BLB12/30/6a: Handle. Fabric: Fine red/brown fabric with fine white and grey inclusions and mica; yellow/cream exterior; centrally ribbed flat strap handle. Source: Crete? Type: Unknown. Date: Unknown. Context: Bulebel SU 30, Phase 2.

### **Fine wares (B1-B41)**

#### ***Local fine wares (B1-B27)***

The Maltese Islands are not usually synonymous with the production of Roman fine wares. Indeed, fine and table wares are usually thought of as finely made, glossy slipped, eating and drinking vessels that were imported from overseas production centres in Italy and North Africa. This study has shown, however, that finely crafted table wares were manufactured on Malta and Gozo. These include a series of red-slipped and thin-walled cups and bowls dating to between the early first century BC to at least the mid-fourth century AD. Fine wares by definition include pottery vessels, usually those associated with eating and drinking, which have a slipped surface, both for practical as well as aesthetic purposes. Walls are thin, well-made, and in many cases fashioned using a mould, produced as imitation of more expensive glassware. In rarer instances vessels are painted or contain relief-moulded decorative elements. For the purpose of this classification, the Maltese fine

wares are divided into two broad groups: 1) red-slipped wares; and 2) thin-walled wares.

#### ***Local red-slipped wares (B1-B22)***

As the heading reveals, the primary feature of this class of fine wares is the red-coloured slip applied to the surface of the vessels. Locally, red-slipped pottery is not a trait only typical of the Roman period. It was a common decorative element to pottery vessels as early as the Red Skorba phase of the Maltese Temple period (c. 4400-4100 BC), the Borġ in-Nadur phase (c. 2500-800 BC) pottery in the Bronze Age, and it became a common element on coarse handmade vessels in the Knights' period (AD 1530-1798). To date, only petrographic studies on Borġ in-Nadur-phase red-slipped pottery have confirmed a Maltese provenance (Tanasi 2015).

The shapes associated with Maltese red-slipped wares are primarily made up of bowls, cups and plates, very often imitating Hellenistic and early Roman black-slipped imported cups and bowls typical of central and southern Italy, the Aegean and eastern Sicily. Another typical feature of red-slipped Roman pottery is that the large majority of vessels are made using Local Fabric 2, with only a handful of red-slipped examples in Local Fabric 1, or indeed any others.

A slip is a fine liquid composed of clay and water, and is applied to the surface of a leather-hard formed vessel prior to it being fired. The colour of the slip is actually achieved through the end result of a chemical process brought on by the choice of iron-rich clay and the oxidizing conditions obtained during the firing process. Studies conducted on Classical-period figure-painted pottery confirmed that the colour and gloss achieved on this type of pottery is primarily due to the presence of the clay mineral illite combined with the right firing conditions (Rice 1987: 18; Henderson 2000: 122-123). It is thus possible that a similar process, making use of iron-rich local clays, particularly the local Blue Clay mixed with weathered Greensands material (Pedley and Hughes Clarke 2002: 56-57), is responsible for the red-coloured slip on pottery during the Roman period.

The chronology ascribed to local red-slipped table wares is far from clear, however, this study has provided some much-needed data to help provide dates for the general introduction and use of red-slipped wares throughout the Roman period on the islands. The earliest presence of local red-slipped wares can be dated to the last few decades of the first century BC and early to mid-Augustan period, and originated from the quarry contexts at Bulebel (phases 1-2). Most notable within these contexts was the complete lack of African Red-Slipped wares, which set this horizon apart from the later second-early third century AD contexts in Foreman Street, which were composed of significantly

more imported red-slipped pottery alongside local fine wares. Local red-slipped pottery continues to be produced at least until the mid-third-mid-fourth century on the basis of the material from the Melita Esplanade. Up until now, knowledge of local red-slipped fine wares derived solely from funerary contexts. A few of the forms (**A1**, **A9** and **A10**) presented below were identified in Roman-period funerary contexts, and were cursorily dated to Sagona's Romano-Punic Phase VI (Sagona 2002). The latter two forms (**A9-10**) presented in this study, also hailed from funerary contexts, but can now be dated with more precision to the mid-third-mid-fourth century on account of its association with two ARS dishes (see catalogue entries **B40.4** and **B40.12**).

A total of 22 forms have been included here, many of which have never been formally classified. It should be noted that the morphological evolution presented remains preliminary and will require further work once new archaeological data are made available from well-stratified Roman sites.

#### **B1. Red-slipped bowl type 1 (Figures 33 and 34)**

This form belongs to a shallow bowl or plate with a double-grooved, flat-top rim, resting on a shallow ring base. It is quite clearly a local red-slipped imitation of an imported Hellenistic black gloss form similar to the one from Berenice (Kenrick 1985: 33, fig. 5.23). Kenrick dated the imported form to the first half of the third century BC on the basis of the impressed decoration on the interior floor. A date in the second half of the third century BC has also been suggested for a similar North African black-slipped form from Bir Messaouda, Carthage (Bechtold 2010: 40-41, fig. 22.8). However, like the previous local examples, the fabric, slip and context suggest a date from the end of the first century BC to the first half of the first century AD.

**B1.1.** BLB12/54/3: Profile, d. 16 (rim), d. 6 (base). Local Fabric 2: Dark orange clay with black glauconite, occasional red grains and fine to medium yellow lime inclusions; thin and matt red-slipped interior and exterior surfaces (**Figure 34**). Context: Bulebel SU 54, Phase 1.

#### **B2. Red-slipped bowl type 2 (Figure 33)**

This second type is included here to document a single example (**B2.1**) of a distinctive, well-made hemispherical bowl, with a squared flat-top rim and thick ring base. The entire vessel is coated in a thin red slip in the same manner as example **B4.2**. The form has been tentatively dated to the Late Republican and Augustan period based on its association with mid-to-late Augustan-period Italian *terra sigillata* examples, which share the same context (see **B36.1-2**). No local

parallels were identified in any of the islands' tomb contexts.

**B2.1.** BLB12/32/20: Profile, d. 14 (rim), d. 5 (base). Local Fabric 2: Dark orange clay with lots of fine black glauconite, fine yellow lime and some white foraminifera inclusions; thin red-slipped interior and exterior surface. Context: Bulebel SU 32, Phase 2.

#### **B3. Red-slipped bowl type 3 (Figure 33)**

Only a single example of this small bowl type was identified (**B3.1**), and it is characterised by a ridged rim. As with the previous type, no comparable vessels have been published on the islands. The fabric and surface treatment are like that of the previous type (**B2.1**) and based on their shared context, have been dated to the same period.

**3.1.** BLB12/32/19: Rim, d. 12. Local Fabric 2: Dark orange clay with lots of black glauconite and yellow lime and foraminifera inclusions; red-slipped interior and exterior surfaces. Context: Bulebel SU 32, Phase 2.

#### **B4. Red-slipped bowl type 4 (Sagona bowl form V: 2a) (Figures 33 and 34)**

This simple bowl form consists of a straight rim with a short carinated shoulder (**B4.1-B4.2**). The surfaces are coated in a thin, streaky, dull red slip (**Figure 34**). Sagona classified a number of similar bowls from funerary contexts as her 'bowl form V: 2a' giving it an early Roman date between the first century BC and first half of the first century AD (Sagona 2002: 182-183). Another example was recorded (or at least published) from the San Pawl Milqi villa excavations (Cagiano de Azevedo *et al.* 1965, fig. 10.4). Although the form is relatively simple, it is possible that the shape was inspired by Hellenistic black-slipped forms originally from northern Italy, from the first half of the second century BC, and become common in Morgantina (Sicily) in the first century BC (Stone 2014: 156). The vertical rimmed-plate remained a popular choice of Republican red-slipped plates in the first half of the first century BC (Stone 2014: 177). A potential variant (**B4.3**), included here on account of its shape, comes from the Foreman Street site, extending the chronology of this form to the late second-early third century AD. However, the larger diameter of this latter example, and the only minor similarity to the former Bulebel examples, suggest that the allocation to this type remains tentative.

**B4.1.** BLB12/28/10: Rim, d. 16. Local Fabric 2: Pale brown clay with fine black glauconite and mixed grey, red and white sandy inclusions; both interior and exterior surfaces coated in a dark red flaky slip. Context: Bulebel SU 28, Phase 2.

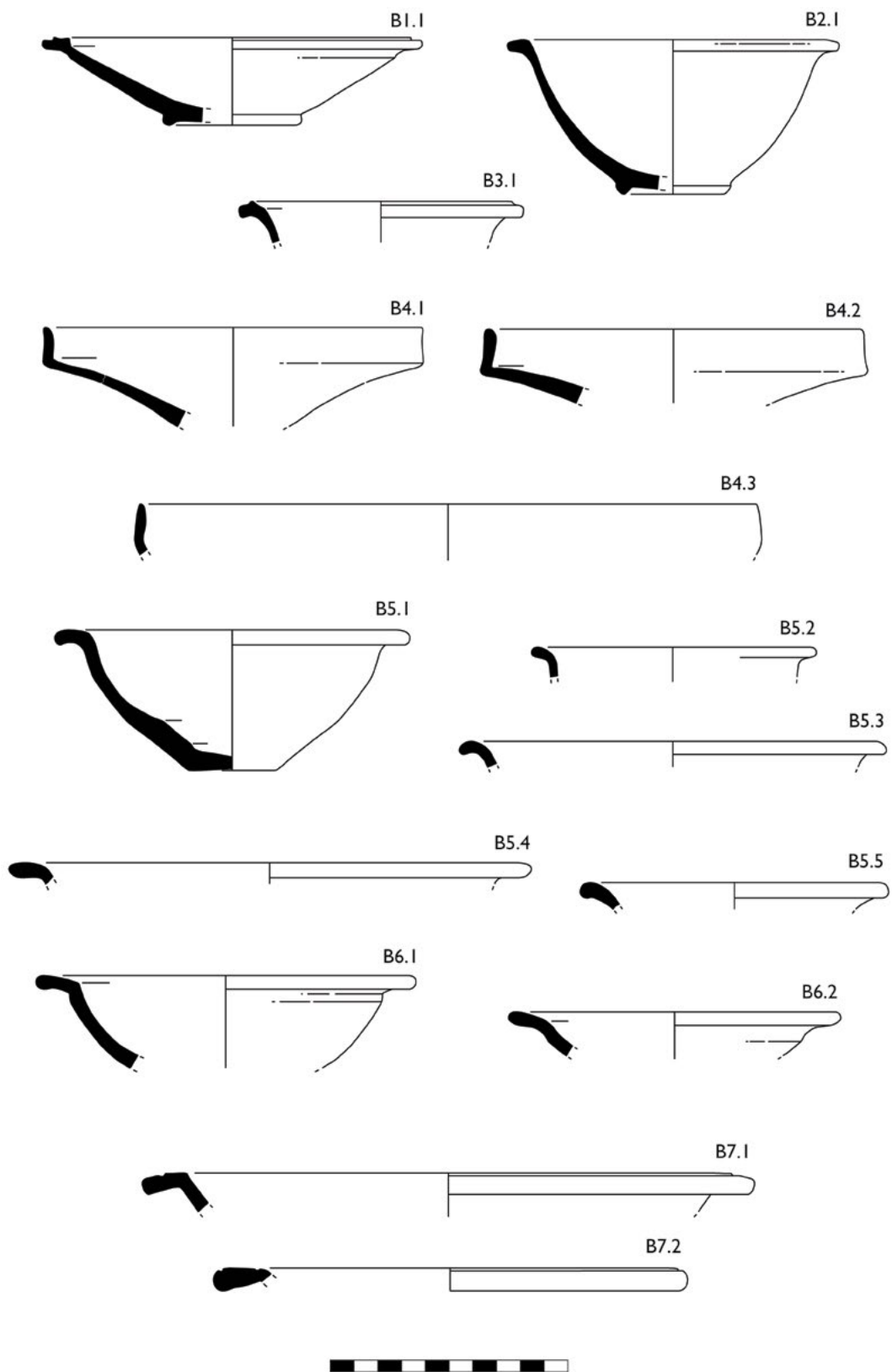

Figure 33: Local red-slipped ware (B1-B7).



**B4.2.** BLB12/28/11: Rim, d. 16. Local Fabric 2: Pale brown with a faint pale grey core with fine grey and white (lime?) sandy inclusions and fine black glauconite inclusions; coated in a thin streaky, matt, red slip on interior and exterior surface. Context: Bulebel SU 28, Phase 2.

**B4.3.** FRM08/42/130: Rim, d. 26. Local Fabric 2: Pale red fabric with glauconite, fine white lime, foraminifera and occasional red inclusions; bright red slip on interior and exterior surface. Context: Foreman Street SU 42.

### **B5. Red-slipped bowl type 5 (Figure 33)**

This hemispherical bowl has a flared and everted simple rim and rests on a simple, flat, string-cut base (**B5.1**). The interior wall contains a slight step towards the base, and since this feature is only found on bowls from the Foreman Street assemblage, it can be linked to a peculiar characteristic of this Gozitan production series, as both slipped and unslipped bowls (type **D4.10**) contain this interior ledge. No Maltese vessels, slipped or unslipped, have been found to contain this detail and may thus be specific to a Gozitan Roman production. Further studies on assemblages from Gozo could provide further comparative literature for this. Although most probably unrelated, a bowl with a very similar morphology was recovered from a disturbed context in Berenice (Benghazi) (Riley 1979: 369, fig. 133, no. 1079. The fabric is unlikely to be Maltese but the shape might suggest some shared influence). The context associated with this form has been dated to the end of the second to mid-third-early fourth century AD.

**B5.1.** FRM08/42/131: Profile, d. 15 (rim), d. 5 (base). Local Fabric 2: Hard orange clay with lots of fine black glauconite, fine yellow lime and fine foraminifera inclusions; thin, matt red slip coating interior and exterior. Context: Foreman Street SU 42.

**B5.2.** FRM08/42/128: Rim, d. 12. Local Fabric 2: Hard pale orange/brown clay with fine black glauconite and fine yellow lime inclusions; thin, red slipped surfaces. Context: Foreman Street SU 42.

**B5.3.** FRM08/42/129: Rim, d. 18. Local Fabric 2: Pale yellow/brown clay with fine black glauconite, white lime and foraminifera and round red ore grain inclusions; thin, matt bright red slipped surfaces. Context: Foreman Street SU 42.

**B5.4.** FRM08/59/24: Rim, d. 22. Local Fabric 2: Pale yellow/brown clay with fine black glauconite, white lime and foraminifera and round red ore grain inclusions; thin, matt bright red slipped surfaces. Context: Foreman Street SU 59.

**B5.5.** MLT84/49378: Rim, d. 15. Local Fabric 1: Hard-fired pale brown fabric with white and yellow lime inclusions; thin red slip on interior and exterior surfaces. Context: Melita SU 1093, Phase 4.

### **B6. Red-slipped bowl type 6 (Figure 33)**

This form is morphologically similar to the previous form (type **B5**) except that the rim is flatter and exhibits a slightly sharper angle offset from the body. The context, date and finish are like those of the previous vessel and thus are contemporary and can be considered different variants.

**B6.1.** FRM08/59/26: Rim, d. 16. Local Fabric 2: Hard orange clay with a thin pale grey core with fine black glauconite, yellow lime, fine foraminifera and fine red ore grain inclusions; thin and worn matt red slipped surfaces. Context: Foreman Street SU 59.

**B6.2.** FRM08/42/127: Rim, d. 14. Local Fabric 2: Pale yellow/brown clay with fine black glauconite, fine yellow lime, foraminifera and large red inclusions; thin matt red slipped surfaces. Context: Foreman Street SU 42.

### **B7. Red-slipped bowl type 7 (Figure 33)**

This bowl form is not very dissimilar to the previous two types (**B5-B6**) except that the flattened rim contains a groove. From the shape, this type appears to be a local imitation of the ARS bowl form, Hayes 6, which also exhibits a groove on the flat part of the rim. Both Local Fabrics 1 and 2 are associated with this form. A couple of locally produced bowls of this form were identified in the Gozo assemblage in association with original ARS Hayes 6 sherds (see **B40.2**). Another local sherd (**B7.2**) comes from the Melita assemblage, from a context dating to the mid-third and mid-fourth century. The Foreman Street example (**B7.1**) can be dated to the end of the second to mid-third century AD. The original ARS form and imitated local forms could be contemporary, as the Hayes 6 has been dated to the end of the first to the end of the second century AD (Hayes 1972: 31), however, like the local Roman-period imitations of earlier Hellenistic black-slipped forms, imitations can be several centuries later than the form that inspired their shape.

**B7.1.** FRM08/42/126: Rim, d. 22. Local Fabric 2: Pale brown clay with fine white foraminifera, black glauconite and some fine red inclusions; pale red-slipped surfaces. Context: Foreman Street SU 42.

**B7.2.** MLT84/49377: Rim, d. 22. Local Fabric 2: Hard-fired pale brown clay with lime inclusions; thick red slip on interior and exterior surfaces. Context: Melita SU 1093, Phase 4.



Figure 34: Local red-slipped bowl forms (B1 and B4).

**B8. Red-slipped bowl type 8 (Sagona bowl form IV-V: 3b) (Figure 35)**

This small cup is characterised by a flared simple rim (B8.1) with a carinated bell-like body that tapers into a flat base (B8.2). Very few red-slipped examples were found associated with a base, however complete non-slipped coarse ware examples (type D5) were found with a flat, sting-cut base. This small bowl form is known – but not common – in Late Punic and Early Roman tomb contexts dated to the first century BC, but a supposedly later-dated form (type D5; Sagona’s bowl form V: 4), which shares the same general morphology except for a ring base, has been dated to at least the first century AD (Sagona 2002: 180-181; see type D5). The few slipped examples identified within the assemblages could point towards an extended chronology, at least until the end of the second century AD on the basis of the examples from Foreman Street, where an over-fired fragment may suggest a production waster (B8.1). The fabric type, however, that of Local Fabric 1, is not typical of the vessels produced *en masse* at Foreman Street, thus this single example could very well represent an earlier mid-first-century-AD residual fragment, like the coarse ware examples found in the Early Roman contexts at Bulebel.

B8.1. FRM08/42/125: Rim, d. 10. Local Fabric 1: Coarse, hard-fired grey fabric with white lime inclusions; thin, flaky red slipped exterior and interior; over-fired grey (?); rim very small so may affect calculation of the vessel’s diameter and inclination. Context: Foreman Street SU 42.

B8.2. BLB12/28/13: Base, d. 3. Local Fabric 2/3: Coarse hard-fired red fabric with fine gypsum, white lime and foraminifera and fine black glauconite inclusions; thin and bright red slipped interior and exterior surfaces. Context: Bulebel SU 28, phase 2.

**B9. Red-slipped bowl type 9 (Sagona bowl form VI: 4a) (Figure 35)**

This wide, shallow bowl is characterised by a sharp (B9.1) or soft (B9.2) carinated body flaring into a simple, yet grooved, rim, and sitting on a flat, string-cut base. The slipped version of this form is common in tomb contexts throughout the Maltese islands and has been dated to after the mid-first century AD by Sagona – her Phase VI (Sagona 2002: 188, fig. 349.42). Unslipped, coarse ware versions are also common (see type D18) and are also associated with tomb contexts (Sagona 2002: 188). A later date in the mid-third-mid-fourth century AD is now suggested for this form based on the presence of this bowl in contexts at Bulebel and Melita Esplanade, which are securely dated by imported pottery (see associated forms B40.4 and B40.11). It is also clear from the association of both complete examples from Bulebel (B9.1-2) that both variants and fabrics (Local Fabric 1 and 2) are contemporary.

B9.1. BLB12/11/4: Complete profile, d. 14 (rim), d. 5 (base). Local Fabric 1: Soft, pale brown fabric with yellow lime, green grog and grey inclusions; eroded dull red slip; flat, string-cut base. Context: Bulebel, SU 11, tomb 3 (T3).

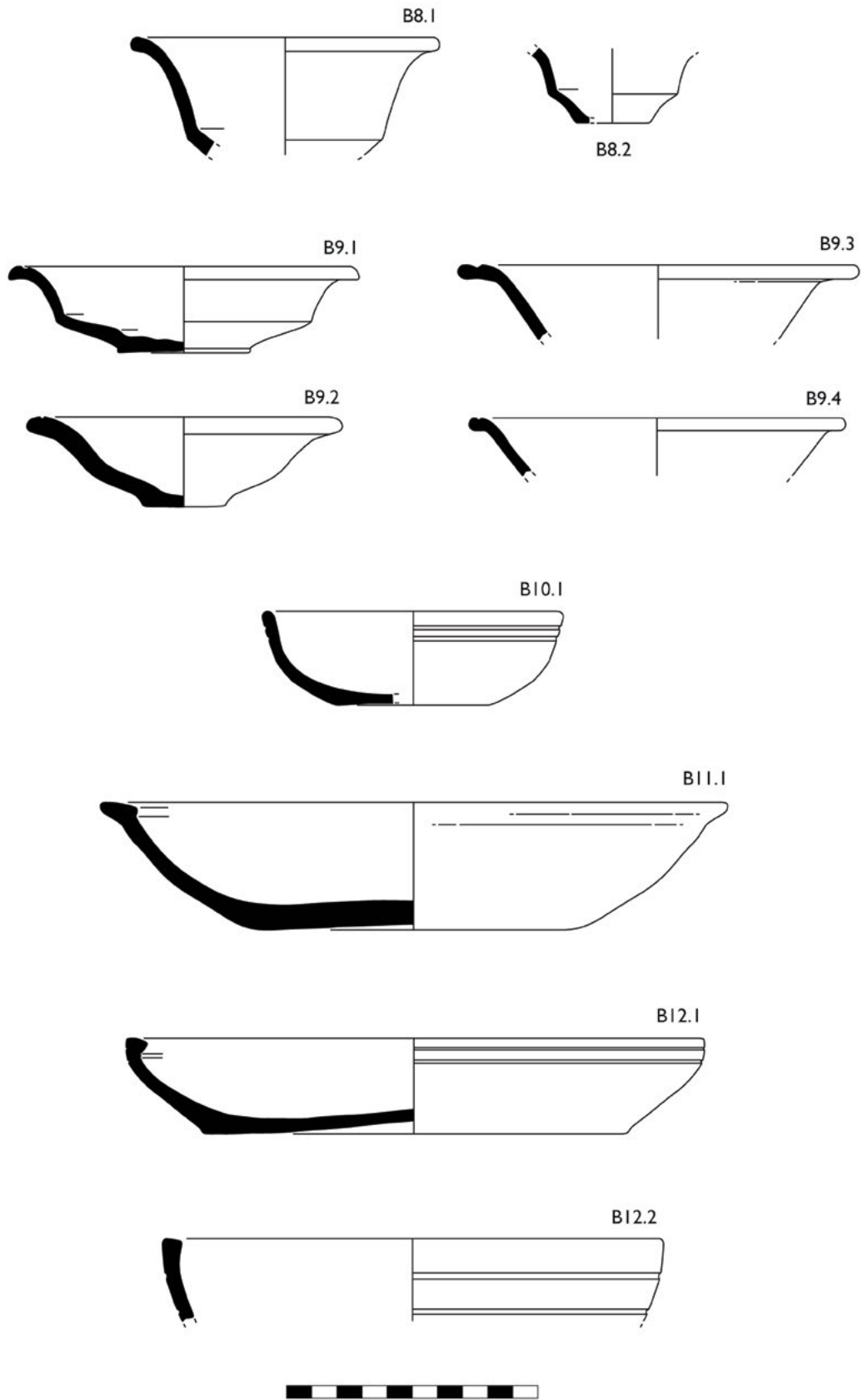

Figure 35: Local red-slipped ware forms (B8-B12).

B9.2. BLB12/71/1: Complete profile, d. 13 (rim), d. 3.5 (base). Local Fabric 2: Pale yellow/brown clay with fine black glauconite, fine white lime and foraminifera and few red ore inclusions; worn and thin red slipped interior and exterior surfaces. Context: Bulebel SU 71, tomb 3 (T3).

B9.3. MLT84/26796: Rim, d. 16. Local Fabric 2: Pale red clay with black glauconite, white lime and foraminifera inclusions; red slipped surfaces. Context: Melita SU 1075, Phase 3.

B9.4. MLT84/26908: Rim, d. 15. Local Fabric 2: Hard-fired red clay with fine black glauconite, fine lime and foraminifera inclusions; thinly applied, dull red-slipped surfaces. Context: Melita SU 1075, Phase 3.

B9.5. MLT84/26830: Base, d. 5. Local Fabric 2: Pale red/brown clay with black glauconite and fine white lime/foraminifera inclusions; dark red-slipped exterior and black interior surface; string-cut flat base. Context: Melita SU1075, Phase 3 [not illustrated].

B9.6. MLT84/49795: Rim, d. 15. Local Fabric 2: Fine pale brown fabric with black glauconite and white lime and foraminifera inclusions; dull red-slipped surfaces. Context: Melita SU 1086, Phase 3 [not illustrated].

#### **B10. Red-slipped bowl type 10 (Sagona bowl form VI: 1d) (Figure 35)**

This form is characterised by a simple red-slipped bowl with a flat base with walls that curve slightly and end in a simple rim with a double incised groove just below the exterior rim edge. This form is known from several tomb contexts and has been found associated with a Tripolitanian II amphora that contained a bronze coin dated to 98-117AD (Sagona 2002: 185, 941-943, fig. 118.5). The single example recovered from the studied assemblages is also from a tomb context associated with pottery dateable to the end of the early third century AD (see types **B9** and **B11**).

B10.1 BLB12/11/3: Profile, d. 12 (rim), d. 6 (base). Local Fabric 2: Pale red/brown fabric with fine black glauconite, fine white lime, foraminifera and fine few red ore inclusions; eroded red-slipped interior and exterior surfaces. Context: Bulebel SU 11, tomb 3 (T3).

#### **B11. Red-slipped bowl type 11 (Figure 35)**

A single example of this large red-slipped dish has a wide flat base and flat-topped rim with a slight interior over-hang. No comparable vessels have been found in the literature or other Maltese tomb contexts. The association with fine ware types **B9-B10**, and **B12** and

an imported ARS form Hayes 31 (**B40.4**) dates this form to between the end of the second and mid-third century AD.

B11.1 BLB12/11/5: Profile, d. 25 (rim), d. 12 (base). Local Fabric 2: Soft pale brown fabric with yellow lime, grog and occasional glauconite inclusions; very eroded thin, dull, red slip. Context: Bulebel SU 11, tomb 3 (T3).

#### **B12. Red-slipped bowl type 12 (Figure 35)**

This large red-slipped dish has a wide, flat, and slightly domed, base with an inward-curving triangular rim and two thin grooved incisions on the exterior surface below the rim. Like the previous dish form (**B11**), no parallels for this vessel are known, however, it is associated with the same tomb furniture (T3), suggesting that they share a similar date (see type **B11**). One fragment (**B12.2**) was included here on account of its similar features, however, it could very well be intrusive within an earlier-phased context (Melita, Phase 2) or it could indicate a long-lived production of this form. The additional black glass-like inclusions within the second example could indicate that it belongs to a different, possibly imported series and thus may not be typologically similar to the first example (**B12.1**). The slight similarity between the two examples could therefore be coincidental.

B12.1. BLB12/71/2: Complete profile, d. 23 (rim), d. 17 (base). Local Fabric 1: Plain buff-coloured fabric with fine mixed white and red inclusions; worn red-slipped surfaces; string-cut base. Context: Bulebel SU 71, tomb 3 (T3).

B12.2. MLT84/26294: Rim, d. 20. Local Fabric 2/3? Pale brown fabric with white, red, black glauconite inclusions, and some possible volcanic (long glass-like) inclusions; red-slipped surfaces. Context: Melita SU 1100, Phase 2.

#### **B13. Red-slipped bowl type 13 (Figure 36)**

This type loosely groups a range of red-slipped hemispherical bowls with simple rims. Based on stratigraphic association, they have been provisionally dated to between the first half of the second and the mid-fourth century AD.

B13.1. MLT84/49796: Rim, d. 12. Local Fabric 2: Fine pale brown clay with black glauconite and lime inclusions; red-slipped interior and exterior surfaces. Context: Melita SU 1086, Phase 3.

B13.2. MLT84/49383: Rim, d. 10. Local Fabric 2: Pale orange clay with fine lime and black glauconite inclusions; thick, waxy red slip on interior and exterior surfaces. Context: Melita SU 1093, Phase 4.

B13.3. MLT84/49275.1: Rim, d. 13. Local Fabric 2: Pale brown clay with black glauconite, fine lime and white foraminifera inclusions; thin red-slipped interior and exterior surfaces; straight-walled rim. Context: Melita SU 1081, Phase 4.

B13.4. MLT84/49275.2: Rim, d. 16. Local Fabric 2: Pale brown fabric with black glauconite and fine lime inclusions; thin red-slipped surfaces. Context: Melita SU 1081, Phase 4.

B13.5. MLT84/25276: Rim, d. 15. Local Fabric 1: Pale brown clay with white foraminifera, lime and grey inclusions; thin matt red slip on interior and exterior surfaces. Context: Melita SU 1072, Phase 6 (mixed context).

#### **B14. Red-slipped bowl type 14 (Figure 36)**

This small red-slipped bowl or cup is defined by a lenticular-shaped beaded rim. Only a single example of this type was identified within the assemblages studied, however, similar coarse ware examples are known from Late Punic and Early Roman contexts throughout the Maltese islands. Despite this, none come from reliable stratigraphic excavations (for Tas-Silġ see Cagiano de Azevedo *et al.* 1965, fig. 6; for Żejtun see Anastasi 2010, fig. 142.4). This example is associated with a context that dates to between the mid-third and mid-fourth century, but since no other parallels are known, this date remains provisional.

B14.1. MLT84/26073: Rim, d. 12. Local Fabric 1: Pale brown clay with white lime and foraminifera inclusions; dull red-slipped surfaces. Context: Melita SU 1096, Phase 5.

#### **B15. Red-slipped bowl type 15 (Figure 36)**

This category includes a single red-slipped example of a shallow grooved-rimmed bowl, which is also found unslipped (see type **D17**). No published local parallels have been identified. This single slipped example, as well as the coarse ware fragments, are associated with contexts from Melita Esplanade that date to between the mid-third and mid-fourth century.

B15.1. MLT84/24828: Rim, d. 24. Local Fabric 2: Pale brown clay with black glauconite, fine white lime and foraminifera inclusions; dark red/brown lustrous slip on interior and exterior surfaces. Context: Melita SU 1066, Phase 4.

#### **B16. Red-slipped bowl type 16 (Figure 36)**

This category covers a wide range of various small mug or cup rims. All examples are red-slipped, made in Local Fabric 2, and share morphological traits with

thin-walled ware examples (see below). They have been grouped together here because of their slightly thicker walls and the nature of their red slip. All sherds have also been dated to between the end of the second and mid-fourth century AD on the basis of their context (Foreman Street and Melita, Phase 3). Similar examples, such as type **B16.4**, are known from elsewhere in the Maltese islands, in particular tomb contexts, and are similar to Sagona's cup form VI: 1a dated to after the mid-first century AD (Sagona 2002: 191-192, fig. 349.49). No complete examples were recovered within the three assemblages, therefore we have no knowledge of what the rest of the body and base looked like and whether there were any handles attached to the vessels.

B16.1. FRM08/59/25: Rim, d. 10. Local Fabric 2: Pale red/brown clay with fine black glauconite, fine white foraminifera and few red grog/ore inclusions; matt, dark red-slipped surfaces. Context: Foreman Street SU 59.

B16.2. MLT84/49856: Rim, d. 8. Local Fabric 2: Hard-fired pale orange clay with black glauconite and lime inclusions; dull red-slipped exterior surface. Context: Melita SU 1085; Phase 3.

B16.3. MLT84/26813: Rim, d. 8. Local Fabric 2: Pale orange clay with black glauconite and lime inclusions (Local Fabric 2); red-slipped exterior surface. Context: Melita SU 1075, Phase 3.

B16.4. MLT84/49857: Rim, d. 7. Local Fabric 2: Pale orange clay with fine white lime/foraminifera and black glauconite inclusions; dull red-slipped exterior surface. Type: Sagona cup form VI: 1a. Context: Melita SU 1085, Phase 3.

#### **B17. Red-slipped bowl type 17 (Figure 36)**

Small bowl or cup with an inward-curving flat-topped rim. Only a single example of this red-slipped form was identified and has been dated to the mid-third/mid-fourth century on the basis of the archaeological context. Since no other local parallels are known this date is preliminary.

B17.1. MLT84/49716: Rim, d. 12. Local Fabric 1: Pale brown clay with fine white lime and foraminifera inclusions; dull red slip on interior and exterior surfaces. Context: Melita SU 1101, Phase 5.

#### **B18. Red-slipped bowl type 18 (Figure 36)**

Small bowl/cup (or jar?) rim with two exterior grooves just below the simple rim. The context of this single example is dated to the mid-third/mid-fourth century.

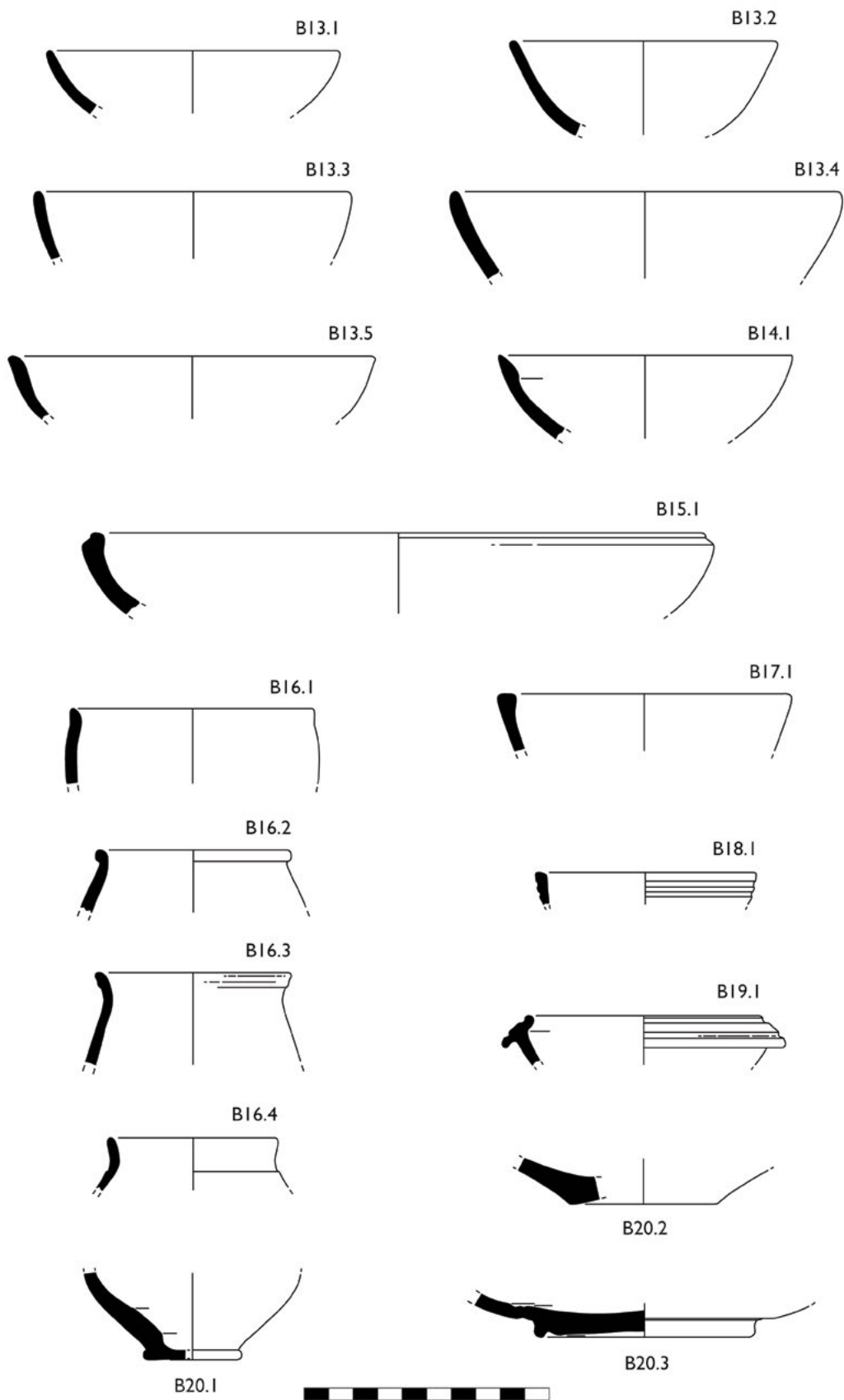

Figure 36: Local red-slipped ware forms (B13-B20).

B18.1. MLT84/49852: Rim, d. 9. Local Fabric 2: Pale orange clay with fine black glauconite and lime inclusions; thin red-slipped surfaces. Context: Melita SU 1085, Phase 3.

### **B19. Red-slipped bowl type 19 (Sagona bowl form VI: 5d) (Figure 36)**

This small bowl has a distinctive grooved and slanting flanged rim. This form is common within local tombs and was classified by Sagona as bowl form VI: 5d, where she dated it to after the mid-first century AD (Sagona 2002: 190, fig. 349.48). Similar bowls are common in local tombs and are associated with type-B10 bowls (see above) and imported objects dated to the second/third century AD (see Sagona 2002: 942-943, tomb 370). The Melita sherd (**B19.1**) is associated with a context dating to the mid-third to mid-fourth century.

B19.1. MLT84/26831: Rim, d. 9. Local Fabric 2: Pale orange clay with fine black glauconite and fine white lime/foraminifera inclusions; red-slipped surfaces. Context: Melita SU 1075, Phase 3.

### **B20. Miscellaneous red-slipped ware (Figure 36)**

This category includes all the recorded miscellaneous red-slipped bases that have not been classified under any other heading because the form remains unknown or uncertain.

B20.1. FRM08/57/32: Cup/bowl base, d. 4. Local Fabric 2: Pale grey clay with fine black glauconite, yellow lime and foraminifera inclusions; red-slipped exterior surface and black-slipped interior. The internal 'ledge' is reminiscent of type **B5.1** except that the base is more of a disc and is not string-cut; over-fired? Context: Foreman Street SU 57.

B20.2. FRM08/42/124: Shallow bowl/plate base, d. 6. Local Fabric 2: Soft pale brown fabric with fine black glauconite, fine pale yellow lime, foraminifera and few red ore inclusions; matt red-slipped surfaces; flat, smoothed base. Context: Foreman Street SU 42.

B20.3. BLB12/32/25: Plate ring base, d. 9. Local Fabric 4? Fine, hard-fired, dark orange/red clay with a thin pale grey core, with some black, matt, spherical inclusions, fine yellow lime/foraminifera and few large angular quartz inclusions; thick, waxy, yet cracked red-slipped surfaces. Source: Local? Sicilian import? Context: Bulebel SU 32, Phase 2.

### **B21. Red-slipped jar type 26 (Figure 37)**

A red-slipped horizontal jar rim with a low raised lip. Only one fragment of this form was recovered from the earliest Bulebel phase. No clear local parallels have

been identified, not even amongst the tomb material. A one-handled flask with a similar-moulded rim and dated to the first century BC is known from San Pawl Milqi but is unlikely to belong to the same vessel type (Bozzi *et al.* 1968, fig. 8.10).

B21.1. BLB12/58/35: Rim, d. 8. Local Fabric 1: Hard, pale orange fabric with yellow lime, white foraminifera and red inclusions; red-slipped exterior, partially covering top interior of rim. Context: Bulebel SU 58, Phase 1.

### **B22. Red-slipped jar type 27 (Sagona urn form VI: 2a) (Figure 37)**

Red-slipped, straight-walled, round-mouthed jar rim with two exterior grooves. This rim shares similarities with a small urn, about 10-14 cm tall, catalogued by Sagona in Phase VI tomb contexts (Sagona 2002: 113, urn form VI: 2a). This exterior surface is coated with a mottled red and black slip, which has since become highly spalled. Sagona does not propose a clear date for this form but it certainly is a Roman-period vessel dating to at least the first century AD.

B22.1. BLB12/28/1: Rim, d. 7. Local Fabric 2: Pale orange clay with a thin pale grey core with fine gypsum (?), fine white lime and foraminifera and fine black glauconite inclusions; mottled red and black, slipped exterior surface. Context: Bulebel SU 28, Phase 2.

### **Local thin-walled wares (B23-B27)**

This class of vessels is characterized by small bowls or cups with very thin walls, usually cast in moulds, and believed to imitate more expensive glassware. The Roman period saw the production of a small range of simple and plain (unslipped) thin-walled cups (type **B23**), as well as finer cups or mugs with beaded or collared rims (types **B24-B26**), sometimes including a handle (**B27**).

### **B23. Local thin-walled cup type 1 (Figure 37)**

This form is characterised by a simple hemispherical cup or small bowl with rim variations ranging from simple to slightly inward-curving (**B23.1-2, 7**), straight (**B23.8**) or everted (**B23.5**). Associated bases are simple and flat (**B23.12**). The main fabric associated with this form is Local Fabric 2, but Local Fabrics 1 and 4 are also recorded. The cups are usually unslipped and are probably mould-made on account of the thin, unsmoothed walls. Parallels for this form can be found amongst the tomb material (Sagona bowl form VI: 1a and possibly even form VI: 2a) and at San Pawl Milqi dateable from about the first century AD (Sagona 2002: 184-185, fig. 349.34 and 39; Cagiano de Azevedo *et al.* 1965, fig. 10.1). The general shape is inspired by a simple

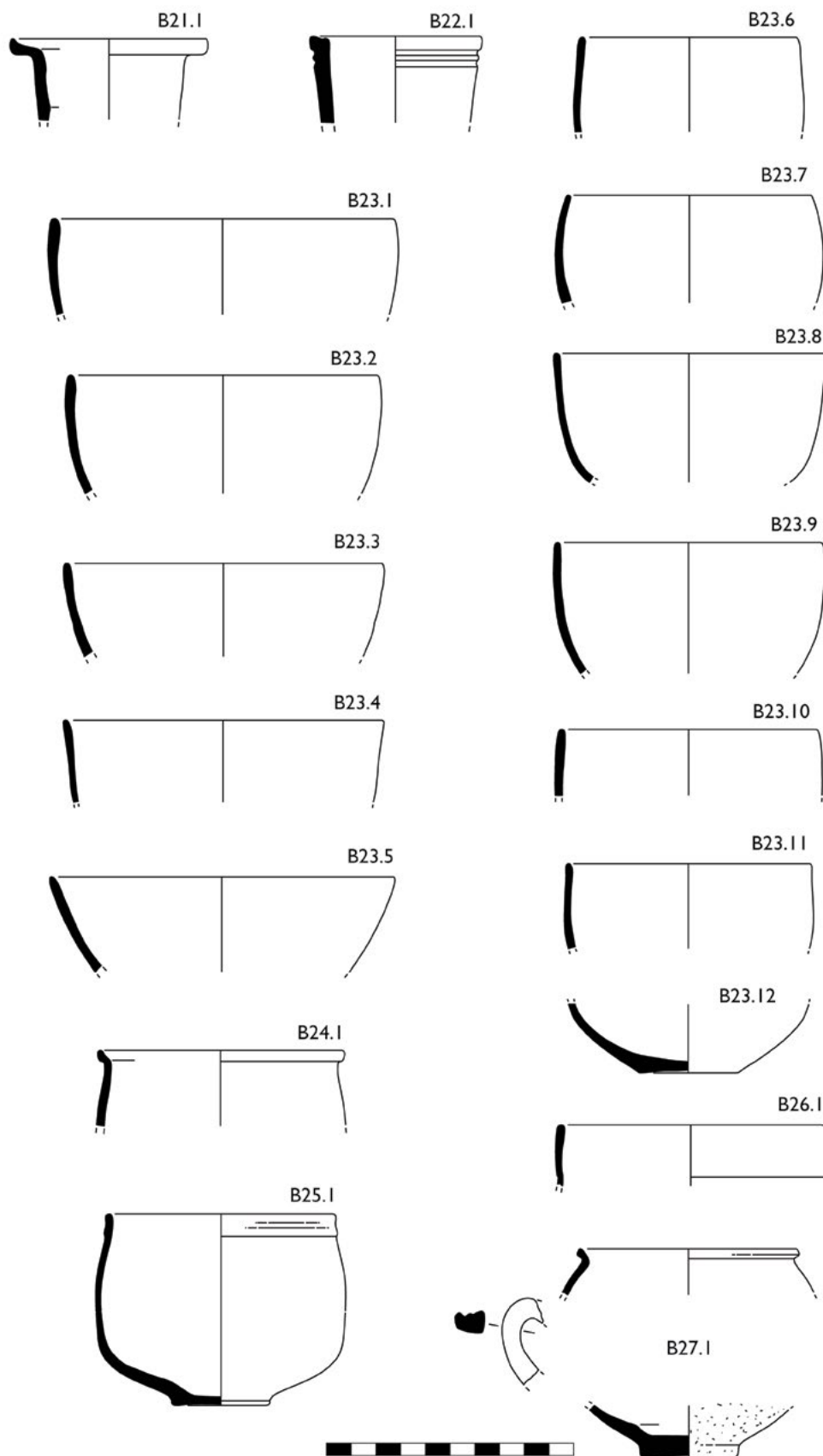

Figure 37: Local red-slipped and thin-walled ware forms (B21-B27).



Augustan thin-walled form – type XXXVI – from Cosa, produced in large quantities from about the second half of the first century BC (Marabini Moevs 1973: 107). That these cup forms are only present at Bulebel, in Phases 1 and 2, further supports the possibility of an early first century AD date.

B23.1. BLB12/58/2: Rim, d. 14. Local Fabric 2: Hard-fired pale red to pale grey clay with lots of very fine black glauconite, fine white lime and foraminifera inclusions; thin cream slip/skin (salt-slipped?). Context: Bulebel SU 58, Phase 1.

B23.2. BLB12/58/49: Rim, d. 12. Local Fabric 2: Red clay with lots of fine black glauconite, white lime and foraminifera inclusions; unslipped. Context: Bulebel SU 58, Phase 1.

B23.3. BLB12/32/12: Rim, d. 13. Local Fabric 2: Pale yellow/pink buff clay with few very fine black glauconite, some red ore/grog, fine white lime and foraminifera inclusions; unslipped white skin. Context: Bulebel SU 32, Phase 2.

B23.4. BLB12/55/8: Rim, d. 13. Local Fabric 2: Red clay with black glauconite, white lime and foraminifera inclusions; unslipped smooth surfaces. Context: Bulebel SU 55, Phase 1.

B23.5. BLB12/58/3: Rim, d. 14. Local Fabric 2: Hard-fired red clay with thin dark grey core with fine black glauconite, few distinct white lime and fine foraminifera inclusions; unslipped. Context: Bulebel SU 58, Phase 1.

B23.6. BLB12/28/14: Rim, d. 9. Local Fabric 2: Hard-fired pale red/pink clay with thin pale grey edges with some very fine black glauconite, fine white and foraminifera inclusions; unslipped grey skin. Context: Bulebel SU 28, Phase 2.

B23.7. BLB12/39/8: Rim, d. 10. Local Fabric 2: Hard-fired pale yellow/grey clay with a thick pale red/pink core with lots of fine yellow foraminifera and lime and black glauconite inclusions; unslipped grey skin. Context: Bulebel SU 39, Phase 2.

B23.8. BLB12/48/2: Rim, d. 11. Local Fabric 4: Very fine gritty red clay with fine granular gypsum and fine yellow foraminifera/lime inclusion; unslipped smooth surfaces. Context: Bulebel SU 48, Phase 2.

B23.9. BLB12/32/40: Rim, d. 11. Local Fabric 2: Hard-fired red/orange clay with fine black glauconite, foraminifera and some fine lime inclusions; pale yellow skin (salt-slipped). Context: Bulebel SU 32, Phase 2.

B23.10. BLB12/39/3: Rim, d. 10. Local Fabric 4 (**Figure 23**): Hard-fired, granular red clay with fine gypsum, some fine black glauconite and fine white lime inclusions; unslipped smooth surfaces. Context: Bulebel SU 39, Phase 2.

B23.11. BLB12/65/5: Rim, d. 10. Local Fabric 2: Pale red clay with fine black glauconite, few white lime and foraminifera inclusions; unslipped pale pink skin. Context: Bulebel SU 65, Phase 2.

B23.12. BLB12/39/2: Base, d. 4. Local Fabric 2 (**Figure 22**): hard-fired pale orange/brown clay with lots of very fine black glauconite, fine foraminifera and some large white lime inclusions; unslipped pale pink skin; smoothed flat base. Context: Bulebel SU 39, Phase 2.

#### **B24. Local thin-walled cup type 2 (Figure 37)**

This form is represented by a single everted, beaded rim belonging to a small locally produced cup. It appears to be similar to Marabini Moevs's form XLVII, which developed in the Augustan period in Italy (Marabini Moevs 1973: 147). This class of local thin-walled vessels probably belongs to Sagona's loosely grouped cup forms VI: 1a-b, although no handles were found associated with the Bulebel example (Sagona 2002: 191-192, fig. 349.49-50). The typical fabric used in local thin-walled cups of this sort is Local Fabric 4, and is usually unslipped, but there are instances where a thin dark red slip coats the surfaces. Only a single fragment of this particular rim type was identified from Bulebel and has been tentatively dated to about the early first century AD due to its context.

B24.1. BLB12/58/9: Rim, d. 10. Local Fabric 4 (**Figure 23**): Very fine granular red/orange clay with medium-sized matt black inclusions and a few fine white lime inclusions; unslipped smooth matt dark grey exterior surface. Context: Bulebel SU 58, Phase 1.

#### **B25. Local thin-walled cup type 3 (Figure 37)**

This cup probably belongs to the same general morphological vein as the previous type (**B24.1**) but for a short vertical collared rim and a polished bright orange/red-coloured slip. The base is flat, smoothed and slightly raised. Exact local parallels could not be found, but a similar-shaped cup – although with a different fabric – was found in a surface deposit at Berenice (Benghazi) (Riley 1979: 369, fig. 133, no. 1080). The polished slip might be attempting to imitate early African Red slipped mugs, which are known on Malta, and would support an early first to early second-century AD date (Hayes 1972: 180, e.g. 4).

B25.1. BLB12/28/15: Profile, d. 10 (rim), d. 4 (base). Local Fabric 4: Granular deep red/orange clay with few fine matt black specks and finer white lime inclusions; Smoothed/polished red/orange slipped surfaces; small and ribbed, cut vertical strap handle. Context: Bulebel SU 28 and 23, Phase 2.

#### B26. Local thin-walled cup type 4 (Figure 37)

This collared, simple-rimmed cup appears to be a local imitation inspired by an Italian thin-walled ware form (form XXXVI, group C) from Cosa, which is Augustan in date (Marabini Moevs 1973: 109-110, no. 193). The discovery of a single rim sherd in a late-dated context (Melita, Phase 3) indicates that the fragment might be residual.

B26.1. MLT84/49853: Rim, d. 11. Local Fabric 4: Fine red clay with black matt and fine white lime inclusions; unslipped red-coloured surface. Context: Melita SU 1085, Phase 3.

#### B27. Local thin-walled cup type 5 (Figure 37)

This is the only example of a local handled mug with a slightly raised flat, string-cut base. The rim is simple, slightly everted, and is very similar to type B24. The surface remains unslipped, but the lower half of the vessel was treated with a sand-textured finish. The form is similar to Marabini Moevs's mug form XLVI, finished in an unslipped sand decoration technique that became very common on metallic-glazed thin-walled vessels during the Tiberian period (AD 14-27) (Marabini Moevs 1973: 128). The discovery of this form in a Phase 1 context supports a local imitation probably dating to about the first half of the first century AD or thereabouts. Other bowl shapes, such as Sagona's bowl form VI: 1b, which have this same decorative finish, are known from tomb contexts on the island (Sagona 2002: 185).

B27.1. MLT84/49565: Part profile, d. 9 (rim), d. 4 (base). Local Fabric 4: Fine dark red clay with fine white lime and black matt spherical inclusions; unslipped red surface with fine black and white grit (sand-textured) concentrated on lower half of body; 14 fragments in total. Context: Melita SU 1111, Phase 1.

#### Imported fine wares (B28-B42)

##### Imported thin-walled ware (B28-B32)

#### B28. Knidian ware (Figure 38)

This double-handled, carinated cup form is characterised by a hard grey clay coated with a smooth, grey metallic slip. The form, similar to cups from Berenice and the Athenian agora, is thought to belong to a series of thin-

walled vessels from the island of Knidos and has been dated to about the first century BC (Kenrick 1985, fig. B84; Hayes 2008, no. 1613). An on-going study of the Hellenistic and early Imperial pottery from Knidos is suggesting that this particular cup type formed part of the basic Late Hellenistic/early Imperial dining set, dating from the last quarter of the first century BC to at least the mid-second century AD (Kögler 2014: 169-170, fig. 18). No other examples of Knidian fine ware have been recorded on the Maltese islands to date.

B28.1. BLB12/39/16: Bevelled rim and handle, d. 15. Fabric: Very hard grey fabric with pale brown edges; contains white fine lime inclusions; covered with a crazed, metallic grey slip. The handle is round in section and is topped with a roughly shaped disc of clay; two grooves circle the shoulder, whilst a pair of thinner grooved lines mark the upper half of the vessel. Context: Bulebel SU 39, Phase 2.

#### B29. Thin-walled bowl form XXXVI (Figure 38)

Only one rim fragment belonging to this North African form was identified and belongs to Marabini Moevs's form XXXVI, Group C, seen with examples from Cosa. The form was a very common hemispherical bowl with a single groove mid-body, which started being produced in the first century BC, but mass production took off from the early Augustan period (Marabini Moevs 1973: 109-110). This particular example appears to have been manufactured in north Tunisia on account of the fine quartz-filled red/brown clay.

B29.1. BLB12/32/41: Rim, d. 11. Fabric: Fine red/brown clay with fine granular quartz, fine black and white inclusions (Peacock 2.1?); unslipped. Source: North Tunisia. Context: Bulebel SU 32, Phase 2.

#### B30. Thin-walled bowl form XXV (Figure 38)

This cupped rim is similar to a squat double-handled cup similar to form XXV identified at Cosa, dated from the first century BC, but became more common from the Augustan-Tiberian period (Marabini Moevs 1973: 80-84). The source of this particular example remains uncertain and might be North African on account of the high quartz content, although a Sicilian origin is also possible on account of the fine black inclusions within the fabric.<sup>7</sup>

B30.1. BLB12/55/9: Rim, d. 9. Fabric: Fine granular brown clay with very fine white lime and foraminifera with some fine black inclusions; unslipped brown skin.

<sup>7</sup> When compared to the east Sicilian MRA 1 amphorae, the fabrics are quite similar suggesting that the fabric sources might be similar; see the similarity with inclusion types in Segesta's thin-walled wares (Montana *et al.* 2003).

Source: North Tunisia/Sicily? Context: Bulebel SU 55, Phase 1.

### **B31. Thin-walled bowl form LXIII? (Figure 38)**

This imported form is morphologically similar to the local example recorded above (**B23**), although the fabric is similar to imported type **B30**, probably originating from North Tunisia or Sicily. Close parallels can be sought with form LXIII for the Cosa assemblage, solely on the similarity between the short collared rims, however the absence of a complete profile makes it impossible to determine exactly what form this vessel takes. Form LXIII from Cosa was common from the Claudian-Neronian period (AD 41-68) (Marabini Moevs 1973: 205).

B31.1. BLB12/30/8: Rim, d. 9. Fabric: Fine red granular clay with lots of fine quartz, lots of very fine white inclusions and some fine black inclusions; unslipped. Source: North Tunisia/Sicily? Context: Bulebel SU 30, Phase 2.

### **B32. Thin-walled mug form LXVIII (Figure 38)**

This last group of thin-walled mugs are probably the most common thin-walled vessel on the islands, common in many early Roman tombs. Sagona classifies two general types (cup form VI: 1a-b), although she was quite unspecific when distinguishing between local and imported examples (Sagona 2002: 191-192). This 'pear-shaped' handled vessel is one of the most common thin-walled vessels of the first century AD (Marabini Moevs 1973: 237). The two examples recorded from the Foreman Street assemblage are made in a hard, compact, dark grey clay, probably from an Aegean source, but this remains to be confirmed. It is not clear whether these particular sherds are residual first-century-AD fragments within the Foreman Street assemblage, or were deposited at a later stage.

B32.1. FRM08/42/121: Rim, d. 7. Fabric: Hard, fine dark grey clay with lots of very fine granular quartz and some very fine lime, and very fine mica inclusions(?); unslipped matt grey skin. Context: Foreman Street SU 42.

B32.2. FRM08/42/122: Rim, d. 7. Fabric: Fine dark grey/brown clay with fine quartz and very fine lime inclusions; unslipped mottled grey/brown surfaces. Context: Foreman Street SU 42.

#### *Imported black-slipped ware (B33-B35)*

Only a very small proportion of imported black-slipped ware was recorded within all three assemblages, but they comprise a wide range of sherds dating to the Punic and early Roman period. In general, black-slipped pottery is uncommon on Malta and Gozo. The

handful of fragments presented here are certainly all residual fragments, and only diagnostic examples are illustrated.

### **B33. Miscellaneous black-slipped wares (Figure 38)**

This group comprises two imported fragments; the first (**B33.1**) is a ring base belonging to a skyphos-like vessel; the second (**B33.2**) is a straight-walled squared box-like vessel, probably similar to a pyxis.

B33.1. BLB12/32/21: Skyphos ring base, d. 10. Fabric: Fine pale orange fabric with fine mudstone (?) inclusions. Source: Imported, possibly Eastern? Date: unknown. Context: Bulebel SU 32, Phase 2.

B33.2. MLT84/25797: Straight-rimmed pyxis? Fabric: Fine hard pale orange/brown fabric with fine yellow lime and occasional small black inclusions; glossy varnish-like slipped surface with black to brown dribbled effect on the exterior. Source: Import, Eastern? Type: Unknown. Date: Unknown. Context: Melita SU 1096, Phase 5.

### **B34. Campanian A ware**

This black-slip production is one of the most common Late Hellenistic/Late Republican mass produced table ware circulating the Mediterranean in the last two and a half centuries BC (for a summary overview of the main characteristics of this production, see Py 1993a). The source of this production is the Naples area of southern Italy, with a fine fabric that is typically red/orange to purple/brown in colour, and sometimes contains mica and very fine white inclusions. Vessels are coated with a distinctive metallic grey/black slip. The shapes generally belong to open drinking vessels, i.e. cups and bowls, modelled on Greek and Hellenistic forms (Morel 1994). Examples on Maltese sites are not common, but finds are known from the Żejtun villa (Anastasi 2010: 299, fig. 142.7, no. 184) and the Tas-Silġ sanctuary (Bruno 2009: 178). Within the assemblages studied only six Campanian A wall sherds were found, three from Bulebel and three more from Melita.

### **B35. Campanian C ware (Figure 38)**

This black-slipped series was produced from about the second to first centuries BC and has come to represent a wide spectrum of black-slipped table wares all sharing a grey-coloured fabric. A common source for many of these vessels is Sicily, in particular the area around Syracuse (Py 1993b; Morel 1994: 47). Large plates are quite commonly represented, although the range of fabrics recorded is also rather extensive. Six fragments – most probably all residual – were identified within the Bulebel assemblage studied, including two illustrated below (**B35.1-2**), whilst a single residual fragment

came from Melita. Like Campanian A black-slipped table wares, only a few examples have been recorded in Maltese contexts (Bruno 2009: 172; Anastasi 2010: 303, fig. 142.8, no. 233).

B35.1. BLB12/58/45: Plate wall with central rouletting on interior. Fabric: Coarse light grey fabric with white lime, lots of black volcanic inclusions and some mica; thick, matt, waxy black slip. Source: Southern Italy/Sicily? Type: Unknown. Date: Unknown. Context: Bulebel SU 58, Phase 1.

B35.2. BLB12/57/3: Carinated plate rim, d. 34. Fabric: Fine dark grey fabric with fine white inclusions; eroded and flaky matt black slip. Source: Sicily? Type: Similar to Morel 2275b 1. Date: first century BC. Context: Bulebel SU 57, Phase 1.

#### *Imported red-slipped ware (B36-B41)*

#### **B36. Italian terra sigillata (Figure 38)**

This category represents Italian terra sigillata (ITS), the best known Roman-period table ware synonymous with early Roman mass production and extensive Mediterranean-wide trade. ITS is found on practically all coastal and inland sites in the Mediterranean during the last few decades of the first century BC and early first century AD (for an overview of this important, yet extensive fine ware, see Kenrick 1985: 125-218; 1991; Passelac 1993a). The first ITS workshops were set up in central Italy, but soon after workshops in neighbouring Roman regions (in particular Gaul) developed a multitude of regional variants, which were also widely traded. On Malta, relatively little ITS is found on early Roman sites compared to neighbouring islands and cities within the central Mediterranean. A small number of complete vessels have been recorded from early 20th century excavations at the Roman domus (Rabat, Malta) and amongst the tomb material (Napolitani 2007; Sagona 2002: 75). Unsurprisingly, only five sherds were found in the three assemblages studied, two of which are illustrated below.

B36.1. BLB12/32/47: Profile of small bowl with rouletting on exterior surface of rim, (d. 8), base (d. 4.4). Fabric: Fine pink fabric mixed with yellow clay, lots of air-pockets; fine, smooth lustrous red/brown slip. Source: Central Italy. Type: Conspectus 22.2.1. Date: 20-10 BC. Context: Bulebel SU 32, Phase 2.

B36.2. BLB12/32/48: Base of moulded bowl with relief decoration, d. 7. Fabric: Very fine pink/pale brown fabric with fine lime or mica inclusions, compact; lustrous brown/red slip. Source: Central Italy. Type: Conspectus R11. Date: Mid-/late Augustan period. Context: Bulebel SU 32, Phase 2.

#### **B37. Campanian A (Formally ‘Tripolitanian sigillata’) (Figure 39)**

This tentative category represents a single example of a red-slipped fine ware sherd that shares similarities with what Kenrick cautiously identified as Tripolitanian sigillata in his study on the fine wares from Berenice (Benghazi) (Kenrick 1985: 283). The accumulation of significant numbers of this ware in North African and Libyan contexts originally led to the suggestion of a Libyan production. However, a source in the Naples area has since been suggested (Soricelli 1987; Kenrick 1987). The fine ware is characterised by a fine, slightly granular orange clay with some fine quartz, some fine mica and very fine white lime inclusions; the body is then slipped with a thin bright red/orange slip. This ware has been dated to the Augustan-Tiberian period and does not appear to have continued in production beyond the first century AD.

Only one fragment of this ware was identified within the three assemblage and appears to be more or less contemporary with the date of the deposition. No other example of this production has yet been recorded on the Maltese islands.

B37.1. BLB12/39/6: Rim, d. 40. Fabric: Pale buff fabric with fine lime, mica, and occasional black inclusions; faded thin red slip. Source: Campania. Type: Kenrick 1985 type 399; see Fulford and Timby 1994: 5, fig. 1.3.42-43. Date: Second half of the first century BC/early first century AD (AD 1-40). Context: Bulebel SU 39, Phase 2.

#### **B38. Eastern red slipped ware (Figure 39)**

This category includes a handful of imported red-slipped fragments which most probably belong to the series of Eastern red-slipped wares (i.e. ESA and ESB) produced in the Aegean, Asia Minor and Syrian regions from the second century BC to the first century AD. Eastern sigillata is also not common on Maltese sites, although it was widely distributed within the central Mediterranean prior to the saturation of the fine ware market by Italian red-slipped wares (for an overview of Eastern sigillata see Kenrick 1985: 223-256; Malfitana 2002). Only five fragments were identified as eastern red-slipped pottery. These were characterised by fine pink or yellow clays with few visible inclusions, some mica, and coated in bright red slips. The fragments recovered are not diagnostic enough to allow better identification of the forms and production types.

B38.1. FRM08/42/96: Small lekythos/flask rim, d. 3. Fabric: Fine pale yellow/pink fabric with very fine paste voids with few visible inclusions; coated in a bright red slip. Source: Asia Minor? Type: ESA?

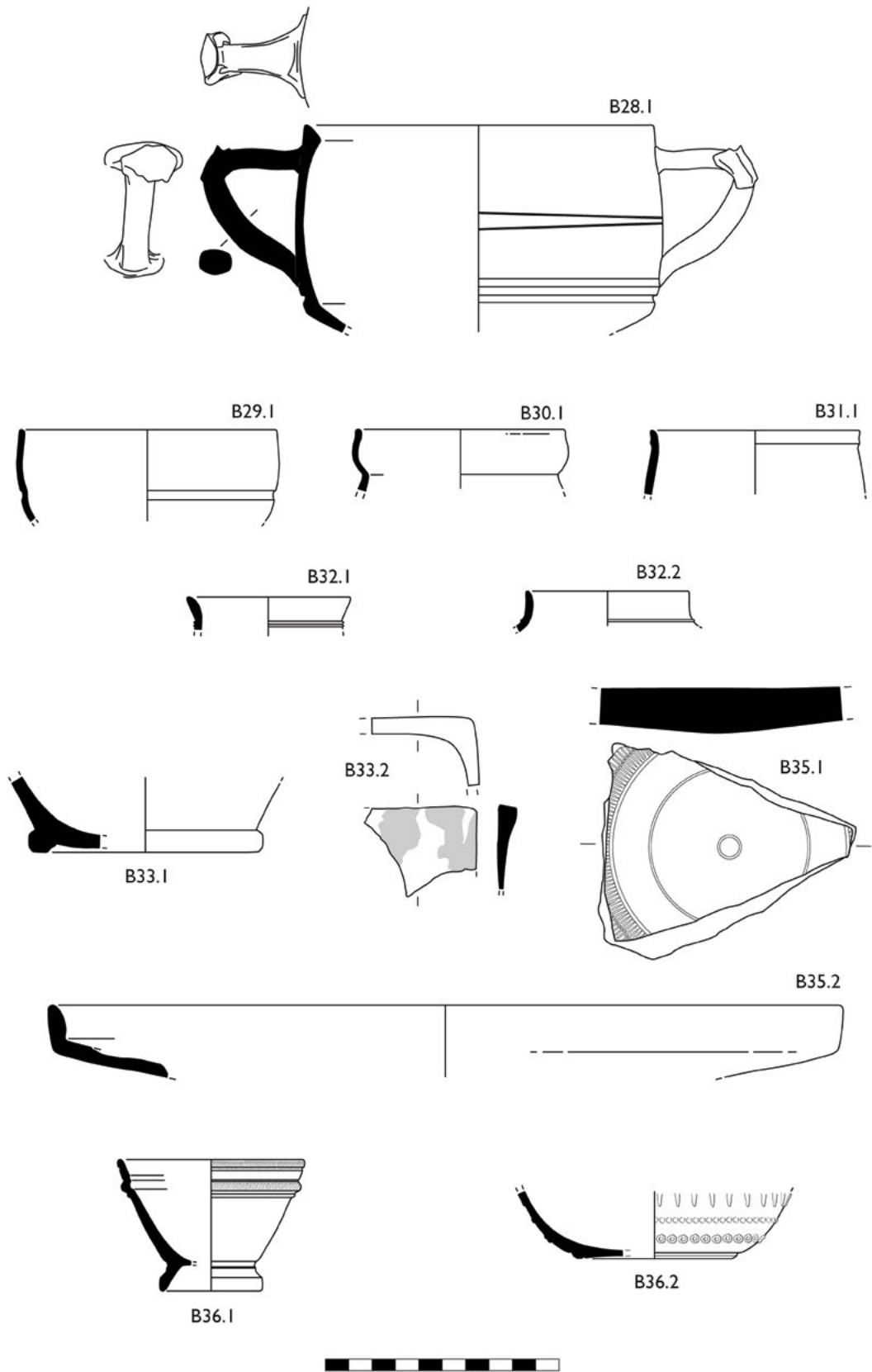

Figure 38: Imported thin-walled ware (B28-B32), black-slipped ware (B33-B35), and Italian terra sigillata (B36).

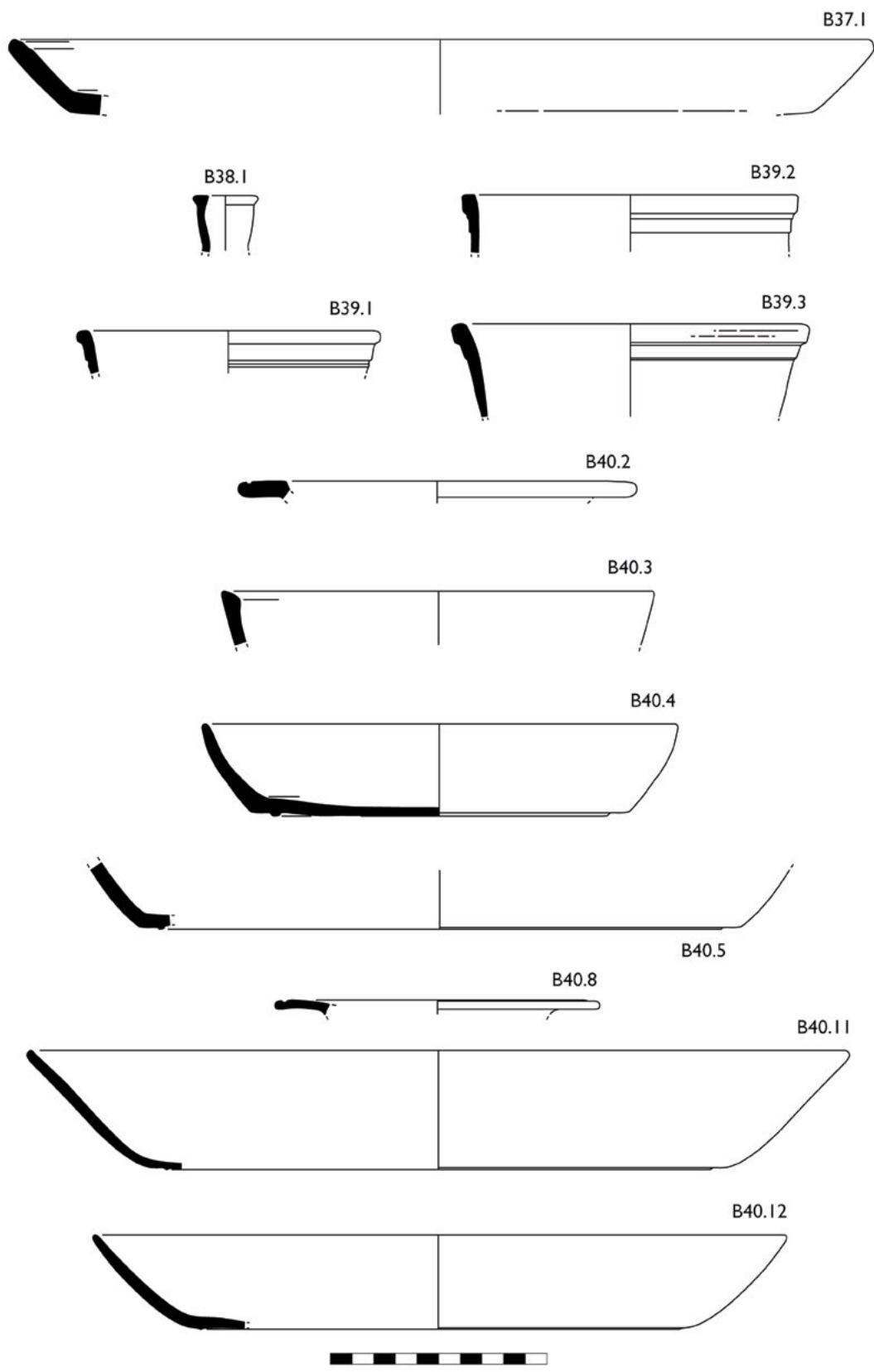

Figure 39: Imported red-slipped ware forms (B37-B40).

Unknown. Date: Unknown. Context: Foreman Street SU 42.

B38.2. MLT84/49793: Small flat bowl base, d. 8. Fabric: Fine yellow fabric with an eroded red slip on the exterior surface. Source: Eastern. Type: Unknown. Date: Unknown. Context: Melita SU1086, Phase 3 [not illustrated].

### B39. Corinthian relief ware (Figure 39)

Corinthian relief ware represents a group of small mould-made bowls with straight vertical walls and a moulded squared rim and a low ring foot. The walls are usually decorated with low relief scenes and images. The fabric is pale orange to buff in colour with very fine round quartz and fine white/grey inclusions. The bowls are then slipped with a thin and unevenly spread dull red slip. The main production zone for these relief bowls is believed to be Corinth, and they are distributed in areas along the eastern and central Mediterranean coast. Dating evidence obtained from the Athenian Agora excavations suggests a date from the mid to end of the second to end of the third century AD (see Canaday Spitzer 1942 and Malfitana 2007). The handful of fragments listed here all come from the Foreman Street contexts and appear to be contemporary with other material in the contexts. In addition to the fragments listed in this catalogue, two more wall sherds and one ring base were identified within the Foreman Street contexts. The only other recorded Corinthian relief ware bowl on the island comes from a Roman tomb in Rabat [583] (Sagona 2002: 1063, fig. 202.2, 5).

B39.1. FRM08/42/98: Rim, d. 14. Fabric: Pale yellow/pink clay with fine paste voids, and grey and white fine sandy inclusions, with thin uneven red slip; moulded relief scenes not legible. Source: Corinth. Date: Second half-end of the second to the end of the third century AD. Context: Foreman Street SU 42.

B39.2. FRM08/42/76: Rim, d. 14. Fabric: Fine pale orange/brown clay with lots of very fine mixed yellow clay or fine lime, with fine paste voids and fine sandy grey and white inclusions; thin uneven red slip; moulded relief scenes not legible. Source: Corinth. Date: Second half-end of the second to the end of the third century AD. Context: Foreman Street SU 42.

B39.3. FRM08/59/28: Rim, d. 16. Fabric: Fine pale orange clay with lots of very fine mixed yellow clay or fine lime, with fine paste voids and fine sandy grey and white inclusions; moulded relief scenes not legible. Source: Corinth. Date: Second half-end of the second to the end of the third century AD. Context: Foreman Street SU 59.

### B40. African Red Slipped ware (ARS) (Figures 39 and 40)

This final category is the best represented fine ware group found on Maltese sites, where fragments of ARS can be identified on every Roman-period site from at least the early to mid-second century AD. Malta is also one of the very limited find spots for some of the earliest ARS forms, which were not widely distributed beyond the immediate production zones in the early first century AD (see Anastasi 2016 for a list of ARS finds recorded in the Maltese Islands).<sup>8</sup> The main production area for ARS is modern-day Tunisia, where different production areas are associated with different ranges of wares and shapes. Several distinct productions (ARS A, C and D) have been identified, each with a particular range of standardised vessels (see Hayes 1972 and Bonifay 2004 for an overview of ARS). The earliest range of forms is known as ARS A production and is generally limited to northern Tunisia, within the Carthage zone (B40.1-3) and it started being produced from the second half of the first century AD. ARS C displays a finer orange clay with a similar-coloured slip and ranges in date from about the third to mid-fifth century AD. Lastly, ARS D characterises the latest thicker-walled and coarser series of large platters that were in production from about the fourth century into the seventh century AD. From about the mid-second-third century onwards a standardised set of ARS vessels, produced primarily for export dominated the fine ware market and had an unprecedented distribution across the entire Mediterranean region.

B40.1. Hayes 3A: MLT84/49270: Rim, d.? Fabric: ARS A1; fine red quartz; small groove on top of rim; thin and bright red finish. Source: North Tunisia. Type: Hayes 3A. Date: Mid-to-late first century AD. Context: Melita SU 1081, Phase 4, residual [not illustrated].

B40.2. Hayes 6: FRM08/42/113: Rim, d. 16. Fabric: ARS A1; fine red fabric with eroded slip. Type: Hayes 6. Source: North Tunisia. Date: End of first to end of the second century AD. Context: Foreman Street SU 42.

B40.3. Hayes 15: MLT84/26918: Bevelled bowl rim, d. 20. Fabric: ARS A? Pink/red quartz fabric; matt pink/red

<sup>8</sup> At least two Hayes form 1 bowls are known on Malta. One, which also has an interesting pre-fired Greek inscription scratched onto the vessel's side, comes from the Roman domus (Zammit 1923: 223-225, fig. 5; Hayes 1972: 18, e.g. 1, fig. 2.1; Carandini and Tortorella 1981: 22, tav. XIII.1). Another comes from the villa at San Pawl Milqi (Bruno 2009: 158, table 2). The only other recorded Hayes 1 forms is a single example from Catania (Malfitana and Franco 2008, table 9.3) and another fragment from Jerba (Fontana, Ben Tahar and Capelli 2009: 264, table 16.7). For other published references for ARS finds on Malta, see Sagona 2002 and Anastasi 2010: 211-216, Appendix 1 for ARS vessels within early Roman tombs; Blagg, Bonanno and Luttrell 1990 for the finds from Hal Millieri, and the relevant sections in the *Missione's* preliminary reports, and Bruno 2009, for the ARS finds at the sanctuary of Tas-Silg and San Pawl Milqi.

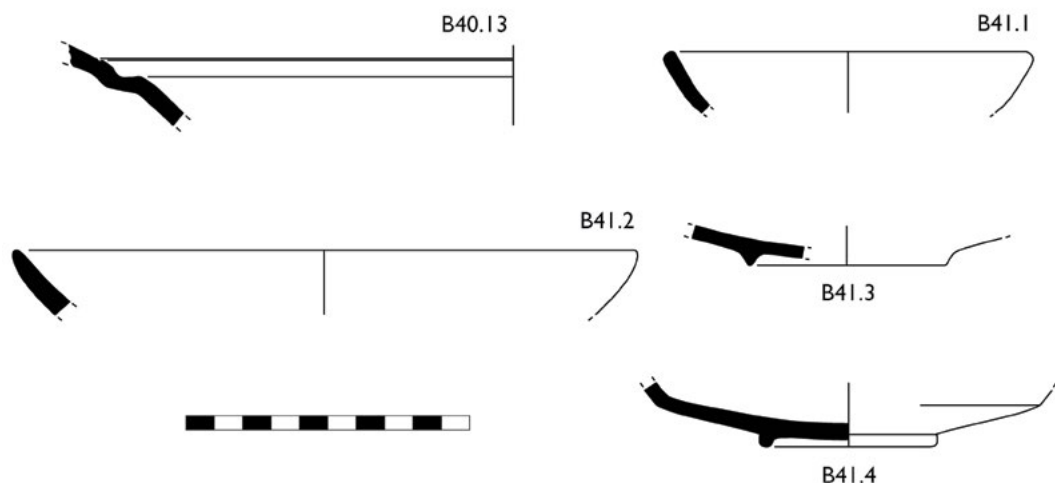

Figure 40: Imported red-slipped ware forms (B40-B41).

smooth slip. Source: North Tunisia. Type: Hayes 15. Date: Early to mid-third century AD. Context: Melita SU 1076, Phase 6 (mixed context).

B40.4. *Hayes 31*: BLB12/71/4: Complete pan profile, rim (d. 22), base (d. 16). Fabric: ARS A2; quartz-rich coarse orange/brown fabric with black and occasional white lime inclusions; interior is covered by a faceted burnished red slip. Source: North/Central Tunisia. Type: Hayes 31. Date: Early to mid-third century AD. Context: Bulebel SU 71, Tomb 3 (T3).

B40.5. *Hayes 31*: FRM08/42/106: Ring base, d. 26. Fabric: ARS A2; red quartz fabric with smooth red slipped surfaces. Source: North Tunisia. Type: Hayes 31? Date: Early to mid-third century AD. Context: Foreman Street SU 42.

B40.6. *Hayes 31*: MLT84/23124a: Thick ring base, d. 20. Fabric: ARS A2; red quartz fabric; internal red slip. Source: North Tunisia. Type: Hayes 31. Date: Early to mid-third century AD. Context: Melita SU 1021 [not illustrated].

B40.7. *Hayes 31*: MLT84/49791: Thick, low and wide ring foot, d. 20. Fabric: ARS A2; gritty orange quartz fabric; faceted red slip on surfaces. Source: North Tunisia. Type: Hayes 31. Date: Early to mid-third century AD. Context: Melita SU 1086, Phase 3 [not illustrated].

B40.8. *Hayes 44*: MLT84/49748: Flat everted rim with groove on top, d. 15. Fabric: ARS C2; fine orange/red quartz fabric; smooth glossy red/orange slip. Source: North Tunisia. Type: Hayes 44. Date: c. 220/40 to late third century AD. Context: Melita SU 1105, Phase 5.

B40.9. *Hayes 45A*: MLT84/49897: Rim, d. 34. Fabric: ARS C2; fine dark red/orange quartz fabric; smooth

Form	Bulebel (tombs)	Foreman Str.	Melita
Hayes 3			1
Hayes 6		1	
Hayes 15			1
Hayes 31	1	1	2
Hayes 44			1
Hayes 45			2
Hayes 50	2		16
Hayes 68?			1
Misc.		22	57
Total	3	24	81

Table 7: Number of ARS fragments from the three assemblages (RBHS).

lustrous dark orange slipped surface; rouletted decoration on top of rim. Source: North Tunisia. Type: Hayes 45A. Date: 230/240-320 AD. Context: Melita SU 1085, Phase 3 [not illustrated].

B40.10. *Hayes 45C*: MLT84/26423: Rim, d. 30. Fabric: ARS C2; red/orange quartz fabric. Source: North Tunisia. Type: Hayes 45C. Date: 300-350 AD. Context: Melita SU 1072, Phase 6 (mixed context) [not illustrated].

B40.11. *Hayes 50A*: BLB12/70/1: Complete dish profile, rim (d. 38) and low and flat grooved base (d. 25). Fabric: ARS C2; fine red quartz; smooth, matt dark red slipped surfaces. Source: North Tunisia. Type: Hayes 50A. Date: c. 230/240-360 AD. Context: Bulebel SU 70, Tomb 3 (T3).

B40.12. *Hayes 50B*: MLT84/49731: Profile, rim, d. 32, shallow groove for base (d. 22). Fabric: ARS C2; dark red/orange quartz fabric; bright orange slip. Source:



North Tunisia. Type: Hayes 50B. Date: c. 350-400 AD. Context: Melita SU 1101, Phase 5.

B40.13. *Hayes 68?*: MLT84/49732: Part of rim, d. 28. Fabric: ARS E? Dark red/orange fabric, smooth red slip. Source: South Byzacena. Type: Hayes 68? Date: 360-470 AD. Context: Melita SU 1101, Phase 5.

#### **B41. Miscellaneous ARS forms (Figure 40)**

B41.1. FRM08/42/110: Bowl rim, d. 13. Fabric: ARS A/C? Fine red quartz; smooth red slip. Source: North Tunisia. Type: Unknown. Date: third century AD? Context: Foreman Street SU 42.

B41.2. FRM08/42/109: Bowl rim, d. 22. Fabric: ARS? Fine red quartz; smooth red slip. Source: North Tunisia. Type: Unknown. Date: third century AD? Context: Foreman Street SU 42.

B41.3. FRM08/42/107: Bowl or plate with low ring base, d. 7. Fabric: Hard and fine red quartz fabric; smooth red slip. Source: North Tunisia. Type: Unknown. Date: second-third century AD? Context: Foreman Street SU 42.

B41.4. FRM08/59/29: Bowl with low ring base with carinated wall, d. 6.3. Fabric: Orange quartz fabric with fine orange/red slip. Source: North Tunisia. Type: Unknown. Date: second-third century AD? Context: Foreman Street SU 59.

#### **Cooking wares (C1-C51)**

This class of vessels includes forms associated with cooking. The catalogue categories are divided according to general shape (i.e. ollas, casseroles, lids etc.), but also distinguishes between local and imported fabrics (i.e. local, Italian, Aegean, African etc.).

##### **Local cooking wares (C1-C20)**

##### **Local ollae (C1-C7)**

#### **C1. Local olla type 1 (Quercia olla type A1/Sagona cooking pot form VI: 1) (Figure 41)**

This cooking pot is characterised by a round-bottomed, globular body with a flat-topped rim. It is a common local cooking form on Malta, produced from at least around the fifth/fourth century BC to about the mid-first century AD (Quercia 2000: 30; 2002: 407, fig. 1; Sagona 2002: 222, fig. 349.53). Local find spots include the sanctuary of Tas-Silġ, where this type was amongst the most common forms occurring for the fourth-second centuries BC (Quercia 2002: 407); and several Late Punic/early Roman tomb contexts across Malta (Quercia 2000: 30; Sagona 2002: 222). Within the

assemblages studied, all but one example of this form came from the Bulebel quarry assemblage in contexts dating to the first century AD, further supporting the dates suggested by both Quercia and Sagona. The single example from the Melita Esplanade excavation came from a context dated to the mid-third-mid-fourth century, and is probably residual. Within this study, vessels of this type occur in several different fabrics, the most common being Local Fabrics 1, 4 and 7.

C1.1. BLB12/32/3: Rim, d. 23. Local Fabric 1: Hard, coarse orange fabric with white/yellow lime inclusions; unslipped. Context: Bulebel SU 32, Phase 2.

C1.2. BLB12/24/17: Rim, d. 28. Local Fabric 7: Coarse orange/brown clay with large white lime/foraminifera and pale red grog-like inclusions; resembles handmade fabrics, although this vessel is most certainly wheelmade; unslipped. Context: Bulebel SU 24, Phase 2.

#### **C2. Local olla type 2 (Quercia olla type A2) (Figure 41)**

This form is morphologically similar to the previous olla except that the spherical body is smaller in diameter and the rim is triangular in profile. This form is less common than Quercia's type A1 (C1) and although it is attested at Tas-Silġ, where Quercia suggests a date from the end of the 7th century BC onwards (2002: 410), a secure date remains to be established. In the present sample, only two rim sherds were identified at Bulebel from Phase 1 contexts, supporting a mid-first century BC to mid-first century AD date.

C2.1. BLB12/59/2: Rim, d. 16. Local Fabric 4: Hard-fired, fine brick-red-coloured clay with fine black, matt, spherical (glauconite?) inclusions, some fine gypsum and fine white lime inclusions; unslipped. Context: Bulebel SU 59, Phase 1.

C2.2. BLB12/58/23: Rim, d. 13. Local Fabric 1: Coarse pale orange clay with a pale grey core with yellow lime, foraminifera and mixed grey and pale red inclusions; unslipped. Context: Bulebel SU 58, Phase 1.

#### **C3. Local olla type 3 (Quercia olla type B) (Figure 41)**

This type encompasses a form of small olla with a characteristic stepped or grooved everted rim intended as a lid-locater. Little is known about this form and local variants may have their origin in Quercia's type B cooking pots common between the fourth and second centuries BC, which share typological similarities to Greek and Hellenistic forms (Quercia 2002: 410-411). These vessels usually have quite thin walls, well-formed stepped, everted rims and tend to be exclusively made in Local Fabric 4. They are common in contexts of the

early to mid-first century AD, and this is attested by the two examples found in Melita from Phase 1 contexts and one from Bulebel. A few examples are known from Early Roman contexts at Tas-Silġ (Sagona 2015, figs 1.115-117), the Żejtun villa (Anastasi 2012: 33, 35, fig. 5.44) and Ħal Millieri (Blagg, Bonanno and Luttrell 1990: 56, fig. 13.12-13). It is apparent that these Greek and Hellenistic cooking pot shapes were the precursors that inspired subsequent Late Punic and Early Roman cooking vessels in Berenice (Riley 1979: 258-259, fig. 102.D497), Sabratha (Dore 1989, fig. 23) and Carthage (and much of North Africa as Hayes form 194) until the end of the first century AD (Hayes 1972: 206-207; 1976: 93-95).

C3.1. BLB12/30/7: Rim, d. 18. Local Fabric 4: Hard-fired, fine deep red/orange clay with fine white lime/foraminifera and black, matt, spherical inclusions; unslipped. Context: Bulebel SU 30, Phase 2.

C3.2. MLT84/49566: Rim, d. 20. Local Fabric 4: Red fabric with fine lime and black, matt, spherical inclusions; grey exterior. Context: Melita SU 1111, Phase 1.

#### C4. Local olla type 4 (Figure 41)

Only a single example of this form was identified and no parallels have been found elsewhere in the Maltese islands. The fabric (Local Fabric 4) indicates a possible local production. The thin-walled everted rim is similar to Late Punic local cooking pots common at Tas-Silġ (Quercia type B), however the thin walls and fabric of this type point towards local manufacture some time during the first century AD. From the lack of other examples, this form clearly does not appear to be common and may also be considered more suited to the thin-walled ware category. The mortar adhering to the surface of this single fragment further supports that it is residual in late Roman layers (Melita, Phase 5).

C4.1. MLT84/49633: Rim, d. 20. Local Fabric 4: Fine red clay with fine lime and black, matt, spherical inclusions; thin-walled; white mortar adheres to surface of vessel. Context: Melita SU 1103, Phase 5; residual?

#### C5. Local olla type 5 (Figure 41)

This olla is characterised by a simple everted and slightly flared rim. Only a single example was recorded within the Gozitan context. No handles or any base fragments were associated with this form therefore it remains uncertain what the whole vessel might have looked like. No local parallels are known in the literature, thus making it difficult to date the vessel type. A late second-mid-third-century date is suggested by the context.

C5.1. FRM08/57/17: Rim, d. 18. Local Fabric 2: Coarse pale orange fabric with black glauconite inclusions; unslipped. Context: Foreman Street SU 57.

#### C6. Local olla type 6 (Figure 41)

Only a single example of this shape was identified within the assemblage. The olla consists of a small beaded lip with an internal groove in the place as a lid-ledge. Like the previous type, no parallels are known and a suggested date of the late second-mid-third century AD is based on the context.

C6.1. FRM08/42/37: Rim, d. 20. Local Fabric 2: Coarse pale orange/brown clay with black glauconite inclusions; unslipped. Context: Foreman Street SU 42.

#### C7. Local olla type 7 (Figure 41)

This olla form is characterised by a collared almond-shaped rim and appears similar in shape to the Pantellerian cooking ware type C44 (see below). Both forms may be inspired by Italian vessels common during the last two centuries BC (Bats 1993a, 358). The two examples identified at Melita are made in local lime fabrics, one with added glauconite (Local Fabrics 2 and 5). No local parallels are known for this rim shape to date and their discovery in Phase 3 contexts at Melita, and the fact that none have been identified in Late Punic and Early Roman contexts at Tas-Silġ, Żejtun and Bulebel, suggests a Roman date from about the mid-third century onwards. Examples of the original Pantellerian form (Sabratha forms 291-292) found at Foreman street (C44.1-2) and Tas-Silġ (Quercia 2006: 1606) have been dated to between the second half of the first century BC and second century AD, like the examples from Sabratha (Dore 1989: 219-220, fig. 61).

C7.1. MLT84/26808: Rim, d. 15. Local Fabric 2: Coarse pale orange fabric with large white lime and glauconite inclusions. The matrix is similar to that of local handmade wares, but the vessel is hard-fired and certainly wheelmade; unslipped. Context: Melita SU1075, Phase 3.

C7.2. MLT84/23208.2: Rim, d. 14. Local Fabric 5: Brick-red-coloured fabric with large white lime inclusions; dark grey/black-fired surfaces. Context: Melita SU 1022.

#### Local casseroles (C8-C10)

#### C8. Local casserole type 1 (Quercia type C3) (Figure 42)

Only a single example of this Late Punic/Early Roman, Greek-inspired casserole form was identified within all the assemblages studied. Quercia identified a

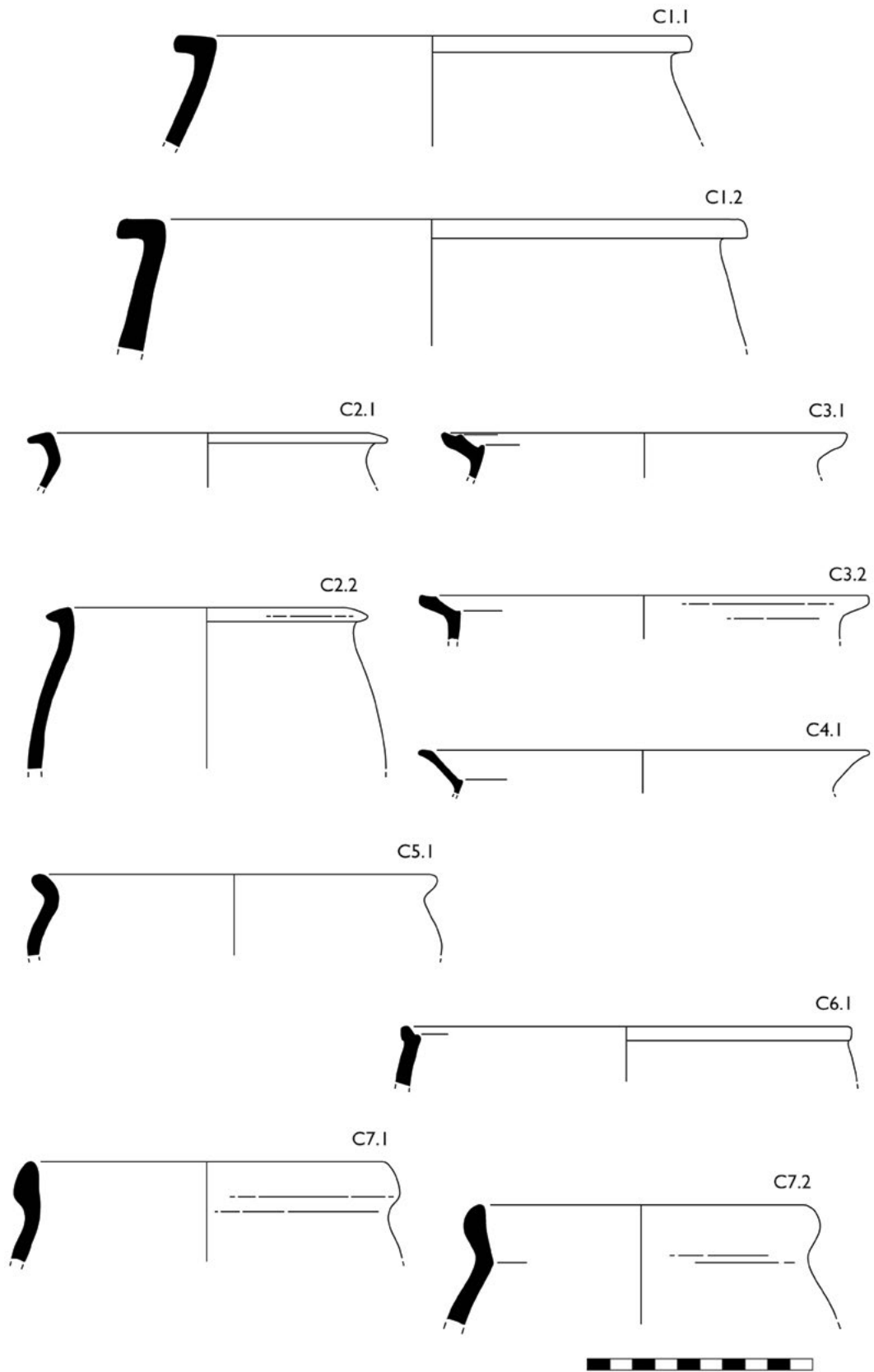

Figure 41: Local cooking ware forms (C1-C7).

similar casserole form within the Late Punic cooking ware at the sanctuary of Tas-Silġ, which occurred in contexts dating to between the fourth and second-first centuries BC (Bats 1993b, 348; Quercia 2002: 414, fig. 4). The presence of the Bulebel example in a Phase 1 context could suggest use of this form during the mid-first century BC–first century AD. This shape also belongs to a Punic/Hellenistic form that is common at other central Mediterranean sites in North Africa (Dore 1989, form 14), Sardinia, and Berenice (Riley 1979: 243, Hellenistic cooking Ware 4).

C8.1. BLB12/58/39: Rim and carinated shoulder, d. 22. Local Fabric 1: Hard-fired, red clay with yellow lime 'reaction rim' inclusions and red grog-like inclusions; dark grey/brown exterior skin. Context: Bulebel SU 58, Phase 1.

### C9. Local casserole type 2 (Figure 42)

This type is represented by a single example from Bulebel characterised by a concave body with a flat-topped, ledged rim to hold a lid. The form shares morphological similarities with type 37 from Sabratha (Dore 1989: 118, fig. 27, no. 37.481), however made in a local glauconite fabric (Local Fabric 2). The Sabratha form has been dated on the basis of its context from the late first century BC.

C9.1. BLB12/32/37: Rim, d. 16. Local Fabric 2: Coarse pale grey fabric with occasional black glauconite and dark grey/black grog-like inclusions; over-fired grey surfaces? Context: Bulebel SU 32, Phase 2.

### C10. Local casserole type 3 (Figure 42)

This form is a local imitation of Riley's ERCW 4 and other Italian-inspired Augustan forms that date to the first half of the first century AD (Riley 1979: 350–351, fig. 100; Bats 1993a, 359). The form is present, but not particularly common, on Malta. A single example was identified within these assemblages (C10.1), whilst a complete example is known from St Agatha's museum in Rabat, Malta, presumably a vessel that was discovered in an early Roman tomb context within the vicinity (Anastasi 2010, fig. 48). Two imported examples with a mica-rich fabric ('*L'impasto, ricco di mica*') came from a funerary context at Ta' Qali in Malta, and one other came from the Italian excavations at the sanctuary at Tas-Silġ, all associated with first-century-AD material (Quercia 2000: 31, fig. 5). The form was the typical early Roman form in Italy during this time (Olcese 1993: 123–124, 218–219).

C10.1. BLB12/55/7: Rim, d. 24. Local Fabric 4 (Figure 23): Hard-fired dark red/orange fine fabric with lots of fine matt black glauconite, fine yellow lime and

foraminifera inclusions; unslipped. Context: Bulebel SU 55, Phase 1.

*Open forms: lids/bowls (C11–C14)*

### C11. Local lid/bowl type 1 (Figure 42)

This form is loosely characterised by a dome-shaped body with hooked rims. It is not clear whether this vessel acted as a bowl, a lid, or both. Similar bowl-like vessels are not uncommon on many Maltese early Roman sites and have been identified at the Żejtun villa made in Local Fabric 5 (Anastasi 2012, fig. 5.42). Contexts able to provide secure dates for the production of this form are scarce, however three examples from Bulebel have been found in contexts dating to the early first century AD. Similar bowls have been recorded in Berenice (Riley 1979, D66–67), whilst typological similarities suggest that these bowls are regional imitations of the better known southern Italian Pompeian Red ware dish (Goudineau 1970, type 1) exported to most of the western Mediterranean during the first half of the first century BC (Passelac 1993b, 546). Form C11.1 is slightly different in that the hooked rim is similar to North African cooking ware lids such as Hayes type 182 but a lack of more examples and the context do little to add more information about the form.

C11.1. BLB12/58/32: Rim, d. 28. Local Fabric 4 (Figure 23): Fine brick-red/orange clay with fine white foraminifera, large yellow lime and black, matt, spherical inclusions (glauconite?); unslipped. Context: Bulebel SU 58, Phase 1.

C11.2. BLB12/65/4: Rim, d. 16. Local Fabric 5 (Figure 23): Hard-fired red fabric with fine white lime and foraminifera inclusions; pale cream exterior skin. Context: Bulebel SU 65, Phase 2.

C11.3. BLB12/58/33: Rim, d. 26. Local Fabric 5: Coarse red/orange fabric with lime, fine foraminifera and black, matt, spherical inclusions (glauconite?); unslipped. Context: Bulebel SU 58, Phase 1.

### C12. Local lid type 2 (Figure 42)

This lid form generally encompasses a series of small early Roman thin-walled lids, either with an everted (C12.1) or inward-curving (C12.2) rim. These lids are typically made in Local Fabric 4 and are not uncommon at the Żejtun villa, both in the 1972 assemblage (Anastasi 2010, fig. 135.3) and more recent excavations by the University of Malta (Vella *et al.* 2017: 135, fig. 10.11). The form is derived from Hellenistic prototypes, seen in several Late Punic/Early Roman assemblages in North Africa (Bats 1993b, 349; for instance, see Dore 1989, fig. 39 for Sabratha form 98 and Vegas 1999: 198–199, form 70 for Carthage). A similar lid type, possibly also

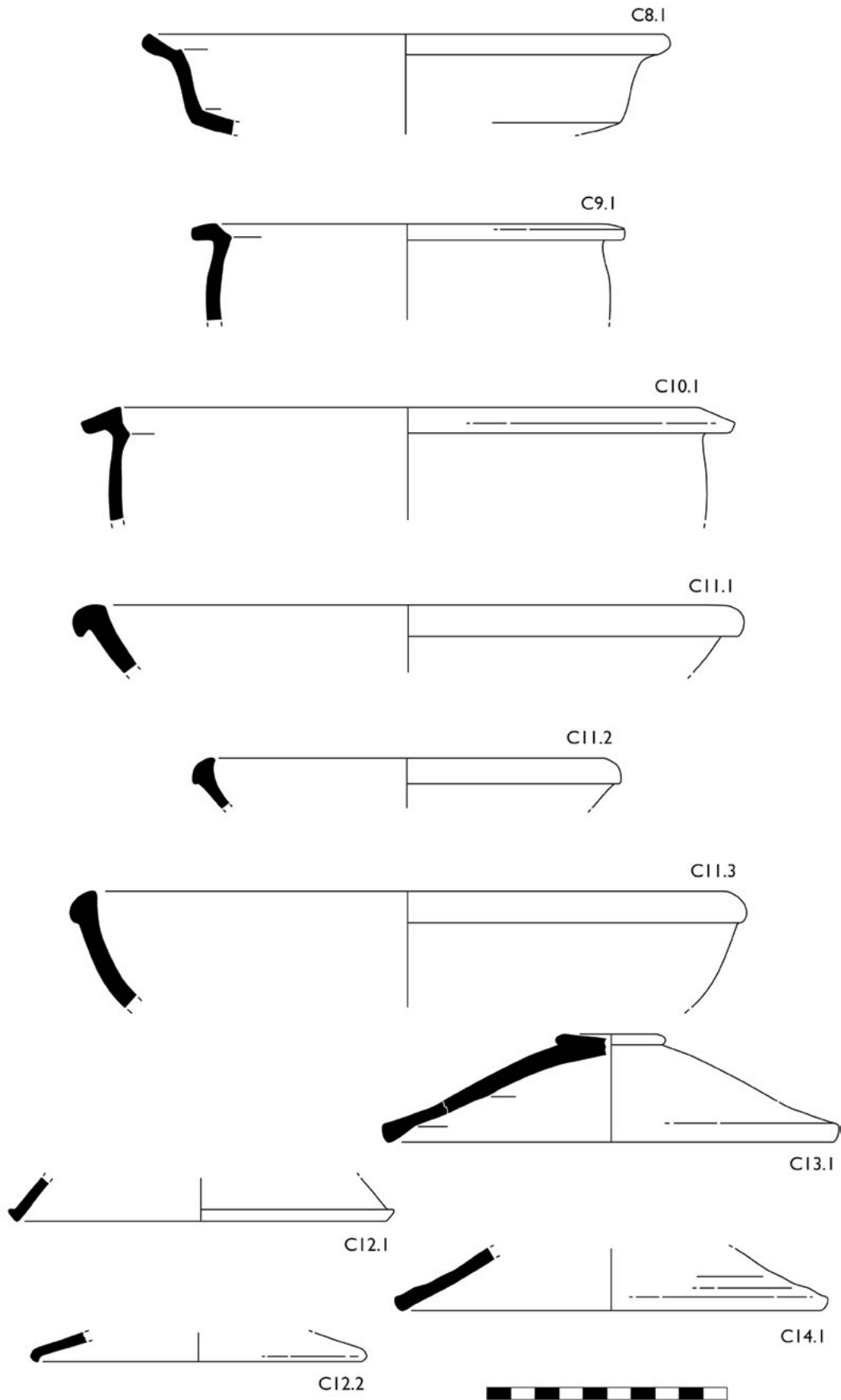

Figure 42: Local cooking ware forms (C8-C14).

Maltese in manufacture, can be identified in Berenice based on the shape and the description of the fabric that closely resembles Local Fabric 4 (see Riley 1979: 312, type D758).

C12.1. BLB12/58/34: Rim, d. 16. Local Fabric 4: Fine dark red clay with fine lime and black, matt, spherical inclusions; unslipped. Context: Bulebel SU 58, Phase 1.

C12.2. MLT84/26282: Rim, d. 14. Local Fabric 4: Fine red fabric with black, matt, spherical inclusions; unslipped. Context: Melita SU 1100, Phase 2.

### C13. Local lid type 3 (Figure 42)

This lid is characterised by a simple squared rim, a shallow body and a narrow disc-shaped flat knob/base. Typologically this form shares similarities with common early Roman North African lid forms such as Hayes 185 (Hayes 1972: 205; Bonifay 2004, fig. 118). The dull red-slipped exterior may be an additional attempt on the part of local Maltese potters at imitating popular North African cooking wares. This was done to conceal the local black-speckled fabric to ensure that the exterior resembles dark red North African clays, whilst the blackened rim edges, seemingly quite deliberate, resemble the 'black-topped ware' finish. No other local examples of this form have been recorded on Malta to date. The context for this fragment suggests that it could be dated to the later Roman period, but whether the fragment is residual or not can only be determined upon the discovery of more fragments of this local type within secure Maltese contexts.

C13.1. MLT84/49890: Profile, rim (d. 19), base/knob (d. 6). Local Fabric 2: Hard-fired pale orange fabric with white lime and lots of black glauconite inclusions; dull red-slipped exterior with black edges. Context: Melita SU 1085, Phase 3.

### C14. Local lid type 4 (Figure 42)

This category includes a handful of lid fragments in Local fabrics 1 and 3, and appear to be imitating first-century-AD North African forms. The shape is characterised by a simple straight-edged, squared rim with some pronounced ribbing on the exterior surface. The presence of these examples within Phase 2 contexts at Bulebel would support a date around the first century, however, this remains tentative.

C14.1. BLB12/32/15: Rim, d. 18. Local Fabric 3 (Figure 23): Hard-fired pale pink/brown gritty clay with fine black glauconite, quartz/gypsum, white and yellow lime and foraminifera and mixed red and grey grog-like inclusions; unslipped. Context: Bulebel SU 32, Phase 2.

### Local Handmade vessels (C15-C19)

This section includes coarse handmade or wheel-turned vessels where production can be traced as far back as the Neolithic and continued well into the fifteenth century. The fabrics used throughout the millennia differ little with each period, however, some subtle differences can be detected. Punic handmade fabrics are harder, flakier and composed of pale brown/pink/grey lime clays. This Punic fabric has been classified by Sagona as 'Punic Pink Buff ware' on the basis of the pottery from the sanctuary of Tas-Silġ (Sagona 2015: 41-43) and MALTA-HP-1 from the recent archaeometric analyses being conducted by Babette Bechtold for the FACEM central Mediterranean fabrics database (Schmidt and Bechtold 2013). Excavations at the chapel of the Annunciation at Ħal Millieri, Malta, uncovered a series of well-preserved handmade vessels similar in shape to types C16, but were securely dated to the 15th century (Blagg, Bonanno and Luttrell 1990: 66-68, fig. 17). The fabric was composed of hard, yet coarse and crumbly grey limey clay and differs little from some of the fabrics recorded here. This only strengthens the view that handmade pottery has a long tradition that saw few changes and alterations for several millennia.

### C15. Handmade olla type 1 (Quercia type A10) (Figure 43)

This form consists of a wide-bodied pot with sagging walls and a simple rim, often curving inwards. This generic vessel shape is known from some Neolithic and Bronze Age pottery on the islands and unstratified finds are notoriously difficult to date because of the longevity of this tradition. Quercia classified this type of vessel as A10 based on the assemblage from the Italian excavations at Tas-Silġ (Quercia 2002: 407, fig. 1). The form is very generic and is found on practically all Late Punic and Roman sites within the Mediterranean, made using local clays.<sup>9</sup> Twenty-seven examples were recorded within the assemblages from Bulebel and Melita. Far fewer examples were found at Melita. None were recorded at Foreman Street.

C15.1. BLB12/55/1: Rim, d. 20. Local Fabric 7: Coarse, pale brown compact clay with large lime and grog inclusions; hackled breaks; smoothed wet-wiped surface finish; pale pink/brown surface colour. Context: Bulebel SU 55, Phase 1.

### C16. Handmade olla type 2 (Figures 43 and 45)

This olla has a flat-topped (C16.1-2) or simple rounded (C16.4) rim, two horizontal lug handles and a wide flat base. The closest local parallel comes from a series of

<sup>9</sup> For instance, see Bonifay 2004: 303-305 for the tradition of handmade vessels in Tunisia.

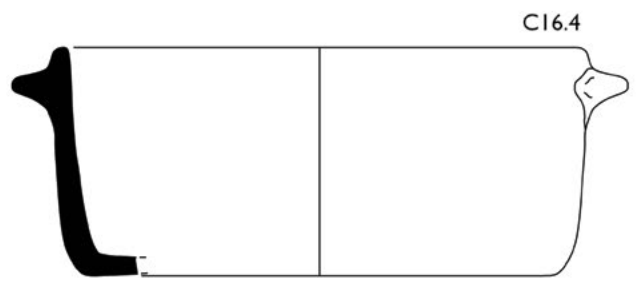
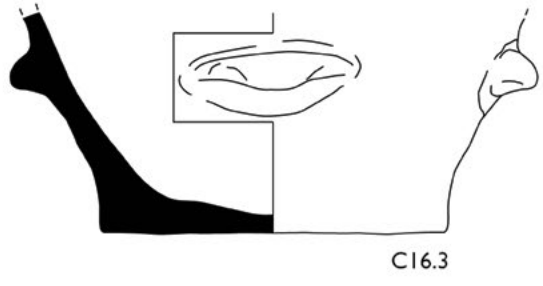
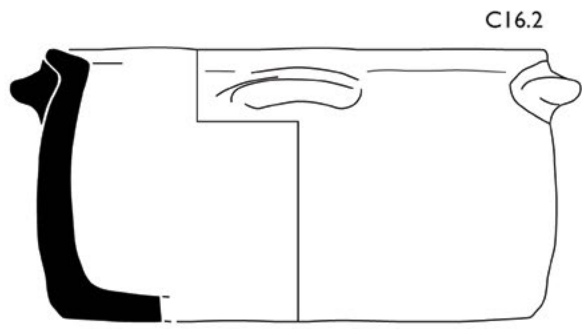
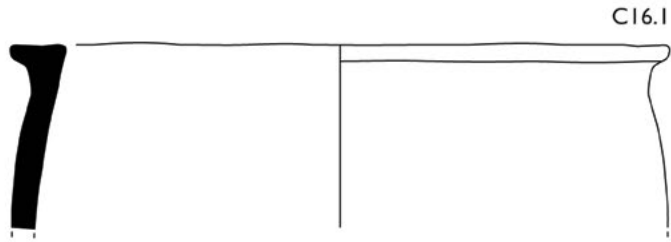
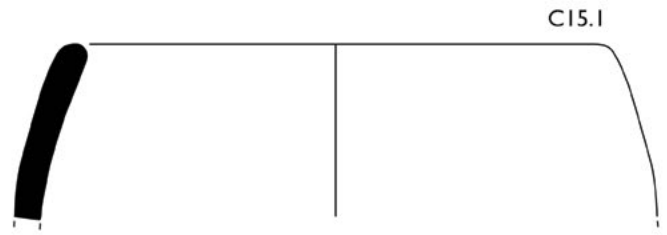

Figure 43: Local handmade ware forms (C15-C16).

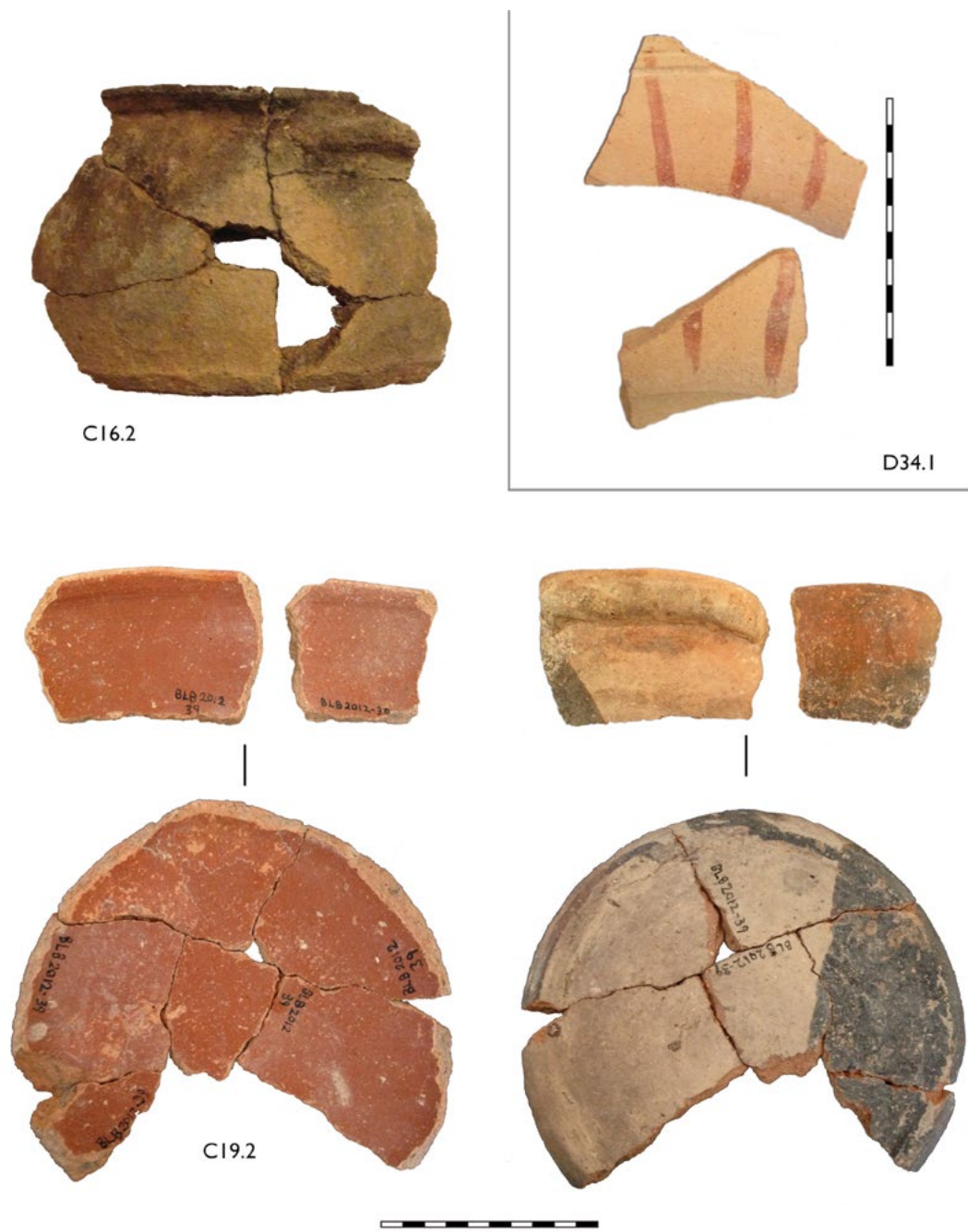

Figure 44: Local handmade and painted wares (C16, C19 and D34.1).

complete handmade pots recovered from beneath a floor level at the chapel of the Annunciation at Hal Millieri, although these were securely dated to the 15th century (Blagg, Bonanno and Luttrell 1990, fig. 17). One example (C16.4) has a straight simple rim and from its context may be later in date.

C16.1. BLB12/58/16: Rim, d. 22. Local Fabric 7 (Figure 23): Coarse pale brown to grey clay with large white/yellow lime and grog inclusions; pale brown interior surface and grey, sooted exterior surface. Context: Bulebel SU 58, Phase 1.

C16.2. BLB12/55/2: Profile with rim and lug handle, d. 20. Local Fabric 7: Hard and coarse pale brown fabric with pale grey core and large lime inclusions; rough, mottled pale brown to grey exterior with evidence of sooting (Figure 44). Context: Bulebel SU 55, Phase 1.

C16.3. BLB12/58/43: Bottom profile with wide flat base and lug handles, base d. 14. Local Fabric 7: Well-fired, medium-hard, coarse pink clay with large lime and grog inclusions; unslipped and rough pale brown/pink surface with no signs of use-wear. Context: Bulebel SU 58, Phase 1.



C16.4. MLT84/26220: Profile, rim (d. 20), base (d. 19). Local Fabric 7: Coarse black-to-grey clay with large lime and grog inclusions; grey/black exterior surface. Context: Melita SU 1099, Phase 5.

C16.5. BLB12/57/5: Bottom profile with wide flat base and lug handle, base d. 50. Local Fabric 7: Coarse and flaky pale brown/pale grey clay with large lime and grog inclusions; unslipped and cracked pale brown and patchy grey/black surfaces showing signs of use-wear. Context: Bulebel SU 57, Phase 1.

### **C17. Handmade Casserole type 3 (Quercia type D4) (Figure 45)**

This shallow dish is characterised by a wide, flat base with short everted (C17.1 and C17.3) and curved (C17.2 and C17.4) walls, most of which end in a simple rim. This is a relatively common form within the cooking ware assemblage from the sanctuary of Tas-Silġ (Quercia 2002: 414, fig. 4). Two examples within the assemblages presented here had a bifid rim (C17.5).

C17.1. BLB12/48/1: Profile, rim (d. 26), base (d. 23). Local Fabric 7: Coarse pale brown clay with large lime and grog inclusions; pale brown smoothed interior surface with a rougher grey and black sooted exterior showing signs of use-wear. Context: Bulebel SU 48.

C17.2. BLB12/24/18: Rim, d. 20. Local Fabric 7: Coarse pale brown/pink clay with large lime and grog inclusions; unslipped, rough surfaces. Context: Bulebel SU 24, Phase 2.

C17.3. BLB12/24/16: Profile, rim (d. 40), base (d. 33). Local Fabric 7: Flaky, coarse pale brown clay with large lime and grog inclusions; unslipped, rough pale brown/cream surfaces with traces of blackened use-wear. Context: Bulebel SU 24, Phase 2.

C17.4. BLB12/24/15: Profile, rim (d. 36), base (d. 27). Local Fabric 7: Hard and coarse grey clay with large lime and grog inclusions; unslipped grey surfaces with traces of darker grey use-wear on the exterior surface. Context: SU 24, Phase 2.

C17.5. BLB12/39/19: Profile, bifid rim (d. 28), base (d. 26). Local Fabric 7: Coarse brown/grey clay with large lime and grog inclusions; hackled breaks; hard-fired; unslipped pale brown to grey surfaces with traces of sooted use-wear. Context: Bulebel SU 39, Phase 2.

### **C18. Handmade Casserole type 4 (Figure 46)**

This form is a new handmade shape identified on Malta, which appears to imitate a common Roman-period Pantellerian ware cooking form (see type C47). The casserole rim is beaded with a thick groove that runs

along the top of the rim and is attached to straight, sloping walls. The Pantellerian ware form is known from contexts dating to around the first half of the third century AD onwards in both Malta (Quercia 2006: 1605-1608, fig. 6, tipo 3) and Sabratha (Dore 1989: 220-223, fig. 61, no. 296.2319). Both Pantellerian and local examples are found exclusively at Melita in Phase 5 contexts, strengthening the argument that local copies are roughly contemporary or later than the original imported Pantellerian vessels. Only two local examples were recorded and were manufactured using a local coarse handmade fabric (Local Fabric 7).

C18.1. MLT84/49644: Rim, d. 32. Local Fabric 7: Coarse pale brown/grey clay with large lime and grog inclusion; hackled breaks; unslipped grey/pale brown surfaces. Context: Melita SUI 1109, Phase 5.

C18.2. MLT84/49601: Rim, d. 32. Local Fabric 7: Coarse pale brown clay with large irregular lime and grog inclusions; unslipped pale brown surfaces with some grey patches. Context: Melita SU 1109, Phase 5.

### **C19. Miscellaneous handmade forms (Figures 44 and 46)**

C19.1. BLB12/54/2: Bevelled rim of small round-bodied olla or bowl, d. 19. Local Fabric 7: Coarse pale brown/grey fabric with large lime and grog inclusions; pale brown exterior surface. Context: Bulebel SU 54, Phase 1.

C19.2. BLB12/39/21: Profile of flat-bottomed pan with inward curving walls and a simple, slightly inverted rim. Two straight horizontal lug handles with an oval section are attached opposite each other just beneath the rim. The unusual painted surfaces (red and black) makes this piece unique and no others have been recorded in Malta to date (Figure 44). It is possible that this is an attempt at imitating Italian cooking wares made in the Pompeian Red ware style. Rim (d. 25), base (d. 18.5). Local Fabric 7: Coarse and crumbly pale orange clay with large lime and occasional glauconite inclusions; matt, red-painted interior surface; cream/pale brown-coloured exterior with large panels painted in black paint. Context: Bulebel SU 39, Phase 2.

### **Imported cooking wares (C20-C27)**

This section includes all the imported cooking vessels thought to be Italian or Aegean in production. No consistent groups could be identified but it is clear that the Bulebel assemblage contained the largest number of Italian vessels, whilst only a handful of small, probably residual fragments, were recorded at the other later-dated sites. Most fabrics identified here are generally brown micaceous or black sand fabrics, most of which can clearly be linked with southern Italian sources,

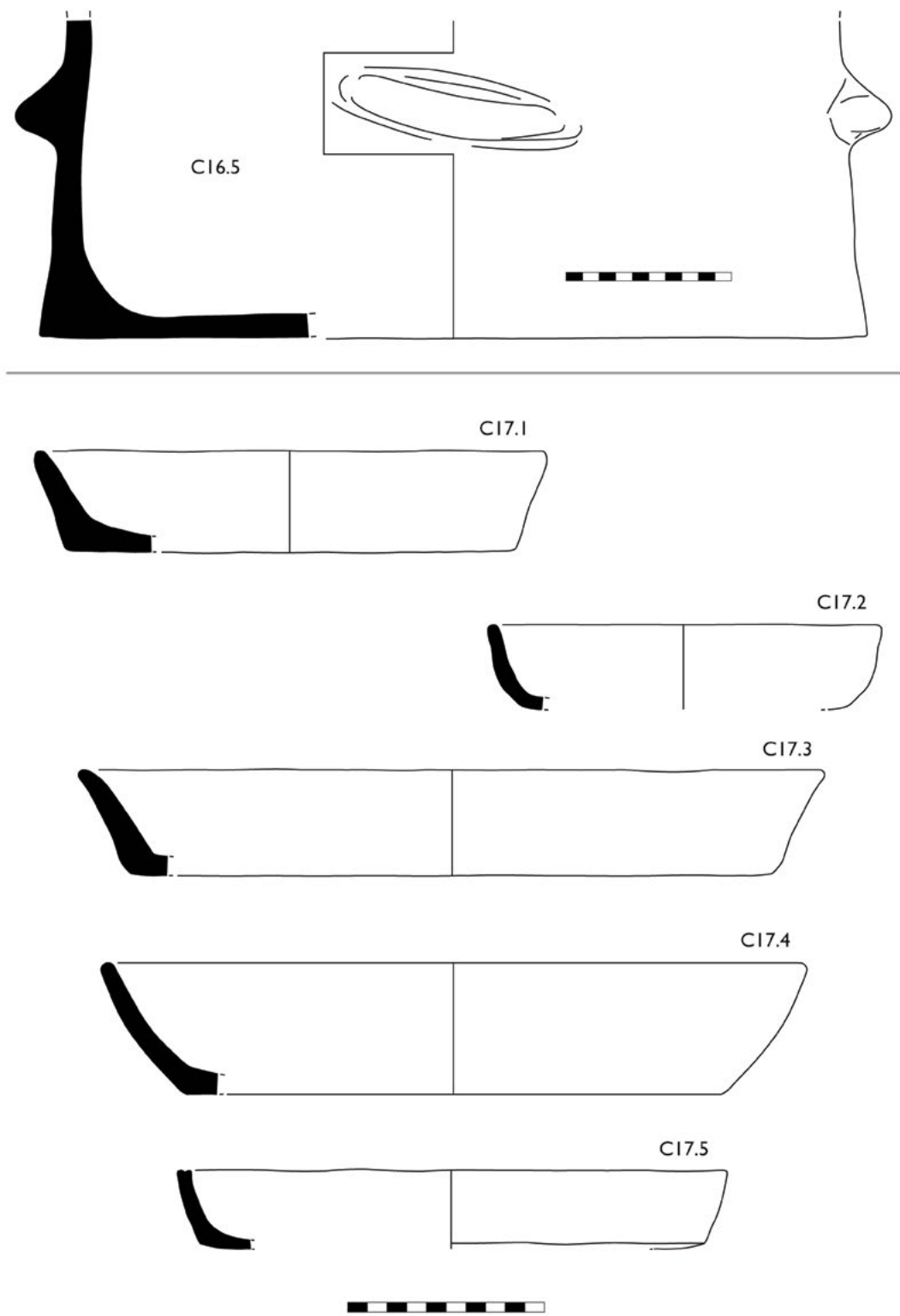

Figure 45: Local handmade ware forms (C16-C17).

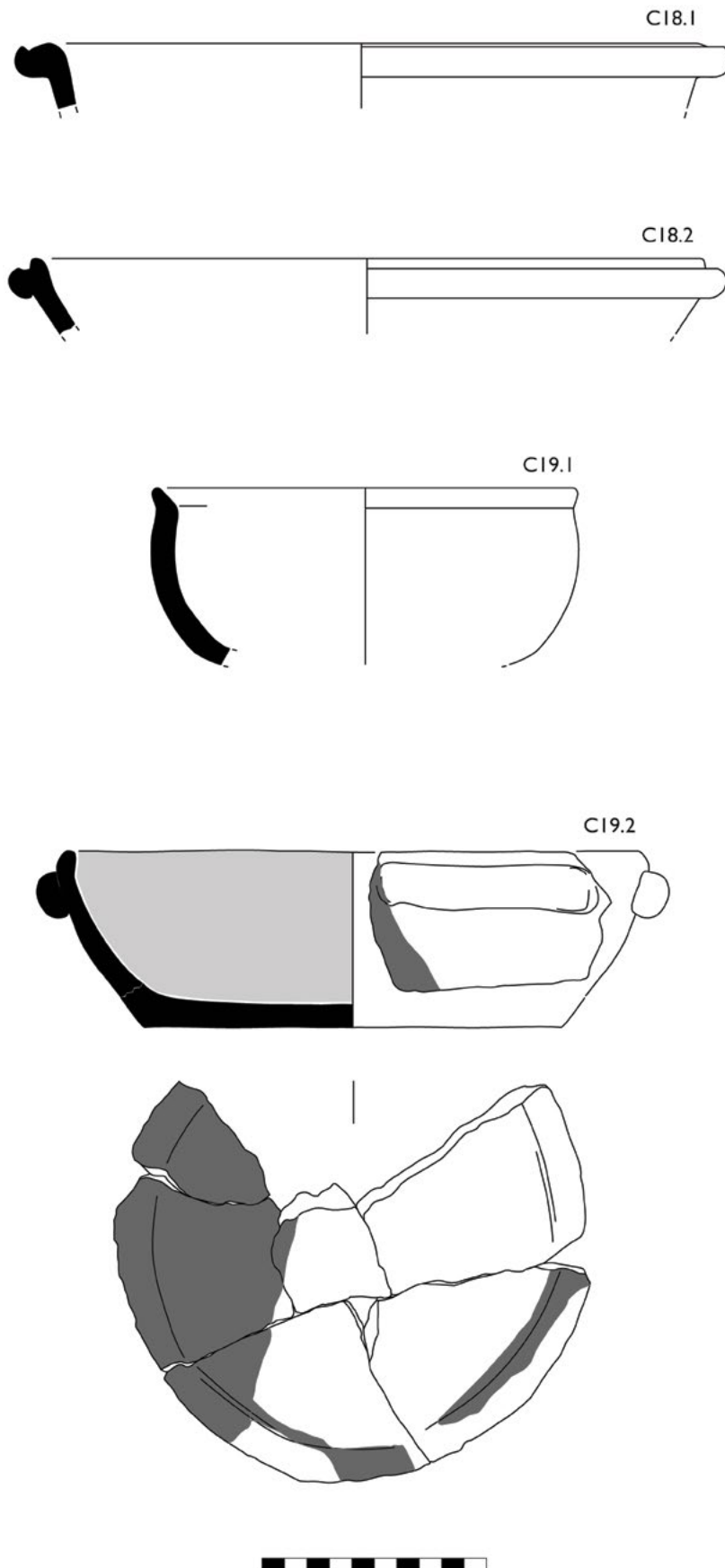

Figure 46: Local handmade ware forms (C18-C19).

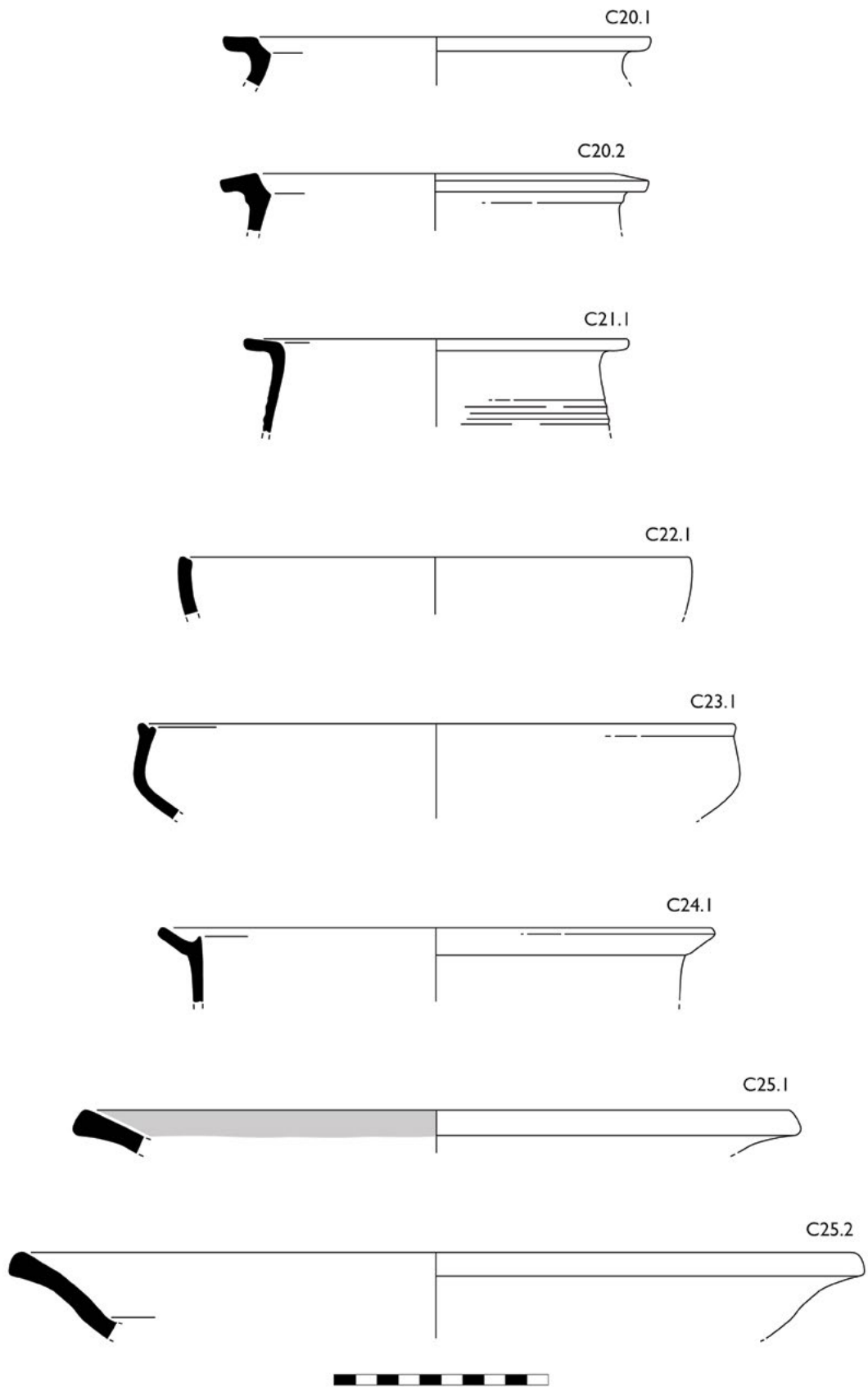

Figure 47: Imported cooking ware forms (C20-C25).

particularly the Campanian region. A few vessels are thought to be Aegean products due to their micaceous fabrics and shape (i.e. C21).

### C20. Stepped olla rim (Figure 47)

This form is loosely characterised by a flat-topped ledged rim intended to hold a lid. No clear parallels have been identified, however, the heavily micaceous brown clay suggests an Italian or Aegean origin. Nothing conclusive about the chronology of these forms can be drawn from the Maltese contexts, although they are most definitely Roman in date.

C20.1. BLB12/28/9: Rim, d. 20. Fabric: Fine dark brown micaceous fabric; unslipped. Source: Southern Italy? Type: Unknown. Date: Unknown. Context: Bulebel SU 28, Phase 2.

C20.2. MLT84/49924: Rim, d. 20. Fabric: Fine dark brown micaceous fabric; unslipped. Source: Southern Italy? Type: Unknown. Date: Unknown. Context: Melita SU 1098, Phase 5.

### C21. MRCW 3/LRCW 2?/Knossos type 2? (Figure 47)

Only one example of this form was identified within the Melita assemblage and it consists of a thin, flat, sloping rim, with a slightly ribbed body. Parallels for this form can be found with the Hayes Type 2 cooking pot from Knossos (Hayes 1983: 105, fig. 5), which belongs to a common Aegean-based regional series typical of the second and third centuries AD. The same vessel is common amongst the finds from the Athenian agora (Robinson 1959, pl. 11, Group J, nos J55-56), and was present at Berenice (as form MRCW form 3), where it was introduced in the early second century AD, and peaked by the early third century AD (Riley 1979: 264, fig. 104, nos 519-520). The vessel also resembles examples of Riley's LRCW form 2, occurring in contexts dating from the mid-third and mid-fourth century AD (Riley 1979: 270-271, fig. 106, nos 547-548). Although they are less common in the western Mediterranean regions, cooking vessels of this type have been found at Leptis Magna (Bonifay *et al.* 2013: 96, fig. 17.52) and Marseilles (Moliner 1996: 246, fig. 12.1-2, 5-6). At least one other Maltese example of a MRCW 3 cooking pot was also identified by Riley at the National Museum in Gozo (Riley 1979: 264).

C21.1. MLT84/49887: Rim, d. 18. Fabric: Brown micaceous clay with quartz inclusions; unslipped; ribbed body. Source: Aegean. Context: Melita SU 1085, Phase 3.

### C22. Early Roman cooking ware 3a (ERCW 3a) (Figure 47)

This casserole form is a shallow, wide-based vessel with low, slightly inward-curving walls and a simple rim,

bisected by a light groove. Only a single example was identified within the Bulebel quarry assemblage. The 'orlo bifido' together with the fine, black sand fabric are characteristic of a Campanian source (Di Giovanni 1996: 78-78, form 2130), and belonged to a common Italian exported series distributed throughout the western Mediterranean basin and North African sites, such as Berenice (Riley 1979: 247-249, fig. 100), Sabratha (Dore 1989: 174, form 152), Carthage (Hayes 1976: 60, no. 12, group X; Fulford 1994: 60-62, fig. 4.7), and Leptis Magna (Reynolds 1997, fig. 73). In Berenice, the form occurred in contexts that have been dated from the end of the first century BC to the late first century AD (Riley 1979: 248). North African imitations become common throughout the central Mediterranean from about the early first century AD onwards (Riley 1979: 248), and continued into the early to mid-second century AD (Leitch 2010: 412, type 3.1.2.3). No North African versions have been identified within the Maltese assemblages, although an African ARS variant, of unknown date and context was identified within the 1972 material from the Żejtun villa (Anastasi 2012: 34, fig. 4.36).

C22.1. BLB12/42/2: Rim, d. 24. Fabric: Gritty brown micaceous fabric with fine black sand inclusions; unslipped. Source: Campania, Southern Italy. Type: Sabratha type 152/ERCW 3a. Date: Early first century BC to the late first century AD. Context: Bulebel SU 42, Phase 2.

### C23. Early Roman cooking ware 3 (ERCW 3) variant (Figure 47)

This squat casserole displays a bulbous, carinated body, and a more pronounced bifid lip. The fabric contains abundant black sand inclusions and thus is probably a Campanian import. Only a single example was identified within these assemblages and no clear parallels are known elsewhere. The context of this single find would suggest a date from the first century BC to about the early third century AD.

C23.1. BLB12/28/6: Rim, d. 28. Fabric: Dark brown grainy clay with fine quartz, white lime and black volcanic sand inclusions; unslipped, blackened exterior surface. Source: Campania? Southern Italy? Type: ERCW 3 variant?. Date: Unknown. Context: Bulebel SU 28, Phase 2.

### C24. Hellenistic cooking ware 4 (HCW 4) (Figure 47)

This casserole has a straight wall with a long everted lip and a short ledge to fit a lid. The fabric is certainly imported to Malta, however, the origin of the vessel remains unclear – the micaceous clay pointing towards an Adriatic or Aegean source. The form is typical of a Hellenistic shallow casserole form classified by Riley as HCW 4, which was dated to the mid-second century BC

based on published Aegean contexts (Riley 1979: 243). The shape is quite typical of the Punic cooking ware repertoire in the central Mediterranean, and shares morphological features with Aegean cooking wares (Vegas 1999: 196, Abb. 104, type 68.1). Local Punic-period versions, similar to this form are known on the islands, with one example also discovered from Bulebel, Phase 1 (see type C8).

C24.1. MLT84/26354: Rim, d. 26. Fabric: Hard-fired and gritty orange/brown fabric with quartz, black, white and micaceous inclusions; black exterior surfaces. Source: Southern Italy, Adriatic coast? Aegean/Eastern? Context: Melita SU 1100, Phase 2.

### C25. Shallow frying pan with everted wall (Figure 47)

This vessel is characterised by a shallow plate-like pan with a wide-brimmed everted and squared rim. Both examples are early Roman Italian imports, with one example (B25.1) belonging to the Pompeian Red ware series on account of the fabric and smooth red slip (Goudineau 1970: 159-186; Peacock 1977: 147-162). These wares are found in small numbers throughout coastal North Africa and further afield from the first century BC until the mid-first century AD. Only a few fragments of this ware were identified within the Maltese assemblages, and of these only this particular form was found. The closest parallel for this shape appears to be a flat frying pan, common in the Campanian kitchen ware repertoire (for instance, see Di Giovanni 1996: 81-82, figs 7 and 12; and Passelac 1993b, 545-546, type R-POMP 17). However, since no handles or complete profiles were recovered in the Maltese contexts, this comparison remains tentative. A wider range of shallow pans, which have not (yet) been identified on Malta, are known to circulate around the coastal areas of North Africa, and in greater numbers (Kenrick 1985: 320-321).

C25.1. BLB12/55/11: Rim, d. 34. Fabric: Gritty brown micaceous clay; bright red-slipped interior surface; unslipped brown exterior. Source: Campania, Southern Italy. Context: Bulebel SU 55, Phase 1.

C25.2. BLB12/32/23: Rim, d. 40. Fabric: Brown to orange gritty micaceous clay; unslipped? Source: Campania, Southern Italy. Context: Bulebel SU 32, Phase 2.

### C26. Domed lids (Figure 48)

This group of kitchen wares is characterised by large domed lids with a beaded (C26.1-2) or squared (C26.3) rim. The beaded versions (C26.1-2) are associated with a low ring base in place of a knob, and have a black sand fabric. The form belongs to a common Italian cooking ware series—*piatti-coperchi*—produced in the

Campanian region, but which is well distributed around the Mediterranean (Scatozza Höricht 1996: 145, fig. 8). Riley classified similar Italian forms as lid types 7 and 8 from the Berenice assemblage, based on parallels with lids from other western Mediterranean sites. These he dated from the late second/early first century BC to the end of the first century AD (Riley 1979: 324). These lid forms are associated with Pompeian Red ware vessels, which date to the same period, however, they do not contain a red slipped surface. The third example, with squared rim (C26.3), resembles a variant of Riley's lid type 8 because of the shape of the small, well-formed knob. The fabric contains micaceous inclusions and could also be a southern Italian product. Based on the comparison with the Berenice examples, this lid type dates from about the early first century AD. Examples from Ostia suggest that the form continued to be produced into the third century AD (Riley 1979: 325, and references therein). No examples from other sites in the Maltese islands have been published to date.

C26.1. BLB12/39/4: Profile, rim (d. 28), knob ring (d. 4.5). Fabric: Coarse brown gritty fabric with fine black sand inclusions; unslipped. Source: Campania, southern Italy. Type: Riley's lid type 7. Date: Late second/early first centuries BC to the end of the first century AD. Context: Bulebel SU 39, Phase 2.

C26.2. BLB12/39/5: Rim, d. 32. Fabric: Coarse brown gritty clay with black volcanic sand inclusions; unslipped brown surfaces. Source: Campania, southern Italy. Type: Riley's lid type 8. Date: Early first century AD. Context: Bulebel SU 39, Phase 2.

C26.3. BLB12/65/2: Profile, rim (d. 33), knob (d. 4.8). Fabric: Dark brown grainy fabric with rough quartz, mica and fine white inclusions; few black sand inclusions; unslipped. Source: southern Italy? Type: Riley's lid type 8? Knob similar to D782. Date: first century AD? Context: Bulebel SU 65, Phase 2.

### C27. Imported handmade vessels

This category was created to include a single wall sherd of a heavily micaceous, soapy-textured, brown-black handmade vessel akin to Peacock's fabric 1.6 (Peacock 1984a, 12). The wall was slightly rounded and suggested that the sherd once belonged to a handmade olla. Peacock and Santoro both suggest that such a fabric could be sourced to south Italy or volcanic regions in the central Mediterranean, such as south Italy, Sicily or Sardinia (Peacock 1984a, 12; Santoro 2007: 368). Diagnostic vessels in this fine micaceous fabric have been dated to the mid-fifth and mid-sixth century AD and are sparsely distributed throughout the western coastal centres of the Mediterranean (Santoro 2007: 368, fig. 4). The context of the body sherd within the Melita assemblage would suggest a slightly earlier date

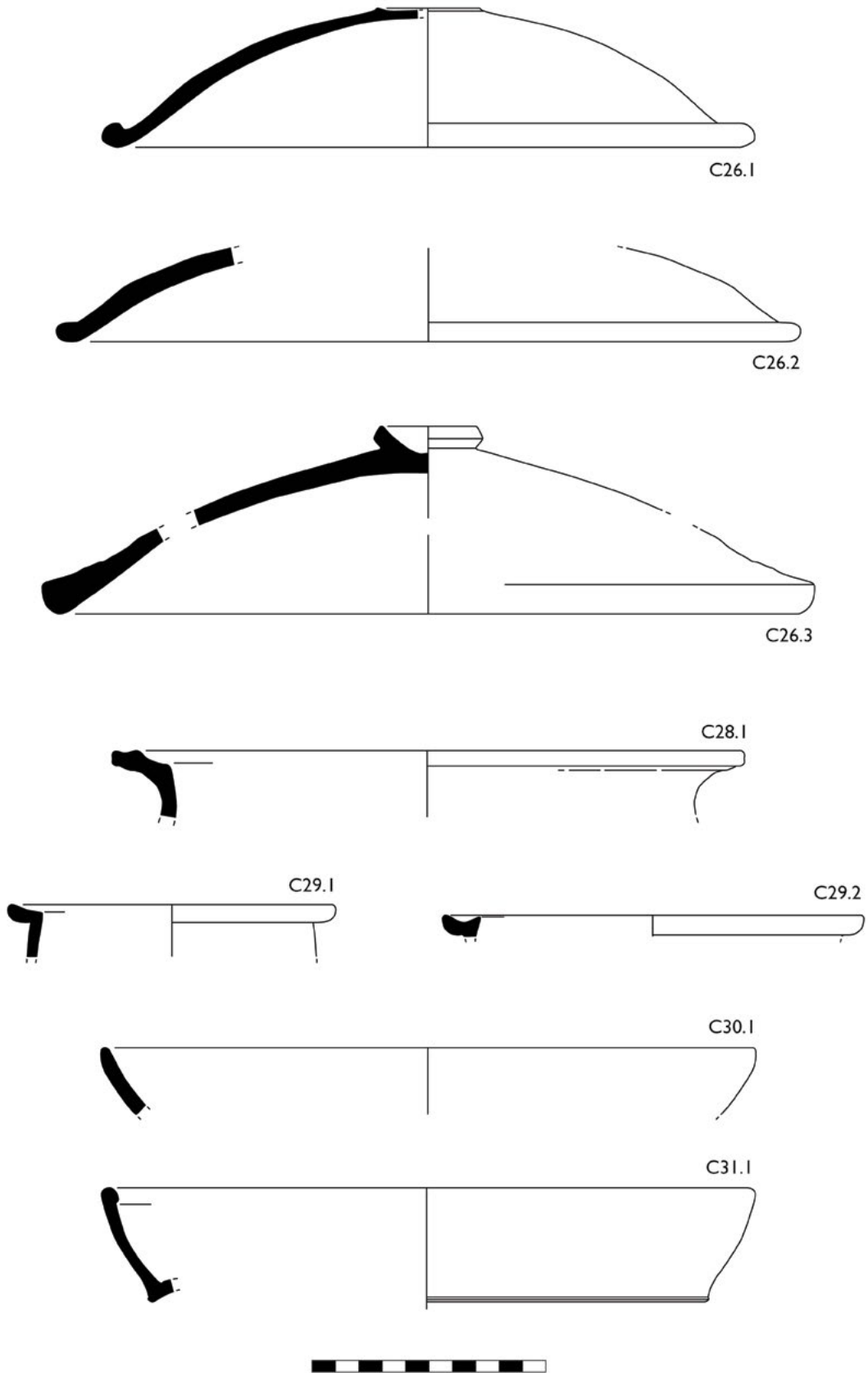

Figure 48: Imported cooking ware forms (C26-C31).

in the mid-third/mid-fourth century, although no other imported handmade Italian cooking wares are known on the islands, so until better examples are identified, this assessment is preliminary.

C27.1. MLT84/49647: Wall of round bottomed vessel; coarse brown-to-black handmade fabric with round quartz, lime and large translucent inclusions and abundant mica (Peacock fabric 1.6). Type: Unknown. Source: southern Italy? Date: Unknown [not illustrated].

#### *North African cooking wares (C28-C37)*

North African cooking wares are by far the most commonly imported cooking ware on Malta, especially from the mid-second century AD onwards. A wide range of classic forms, as well as some more unusual vessel shapes, have been recorded within these assemblages, and display fabrics which originate from centres along the entire perimeter of the Tunisian and Tripolitanian coast.

#### **C28. North Africa stepped rim (Figure 48)**

This vessel is characterised by a stepped everted rim forming the opening of a round-bodied cooking pot. The fabric is brick-red and hard-fired, with a blackened surface along the rim area, typical of early Roman 'black-topped ware'. This form is probably a product of North Tunisia on account of its presence in Carthage (Hayes 1976, cooking pot type C13; Fulford and Peacock 1994, fig. 4.4:42-44) and near-by Utica.<sup>10</sup> No parallels have been identified in central or southern Tunisia. A clear date for this form has not yet been established, however Hayes suggested it was an early Roman form, probably dating to the first century AD (Hayes 1976: 94-95).

C28.1. MLT84/49804: Rim, d. 28. Fabric: Hard-fired, brick-red fabric with quartz and fine lime inclusions, contains some small black inclusions; unslipped with black-topped rim. Source: North Tunisia, Carthage region? Context: Melita SU 1086, Phase 3.

#### **C29. Mid-Roman cooking Ware 1 (MRCW 1) (Figure 48)**

This form is common at Berenice and Crete and was produced between the second and third century AD. A source for the Foreman Street examples remains unclear, although they do match the fabric description given for the local examples at Berenice, despite this form not being particularly common outside of

Cyrenaica and Crete (see Riley 1979: 261, Local Fabric 4?). No other examples are known from the Maltese islands.

C29.1. FRM08/42/111: Rim, d. 14. Fabric: Hard-fired red quartz fabric with fine white lime inclusions; unslipped. Source: North Africa. Type: MRCW 1c. Date: Early third century AD based on the evidence from Berenice (Riley 1979: 261). Context: Foreman Street, SU 42.

C29.2. FRM08/42/112: Rim, d. 18. Fabric: Fine red quartz fabric with fine white lime inclusions; unslipped but with blackened exterior possibly due to use-wear. Source: North Africa. Type: MRCW 1c. Date: Early third century AD based on the evidence from Berenice (Riley 1979: 261). Context: Foreman Street, SU 42.

#### **C30. Hayes 23A (Figure 48)**

This classic form belongs to the widely exported repertoire of North African cooking wares – Bonifay's culinaire (A) type 1B – produced in north Tunisian centres, from the second half of the first century to the beginning of the third century AD (Bonifay 2004: 211, fig. 112; Leitch 2010: 410, type 3.1.2.1). Very few examples of this form are known on Malta. The sherd is recorded at Hal Millieri as a Hayes 23 form, however it remains unclear what variant it belongs to (Blagg, Bonanno and Luttrell 1990: 54). Despite this, its typological successor, Hayes 23B (C31), is better represented on the islands, especially after the mid-second century AD.

C30.1. FRM08/59/30: Rim, d. 28. Fabric: Fine red clay with fine quartz inclusions (Peacock fabric 2.1); unslipped smoothed surfaces. Context: Foreman Street SU 59.

#### **C31. Hayes 23B (Figures 48 and 49)**

Several examples of this casserole were recovered from all three assemblages, each displaying slightly different variants. The earliest examples (C31.1-2), similar to Bonifay's culinaire (A) type 1B.2, have a small round, beaded rim attached to a sagging body, with a curved wall, and a smoothed, red-slipped interior surface (Hayes 1972: 46-48; Bonifay 2004: 211, fig. 112). They are dated by parallels from the first half of the second century to the early third century AD. Later variants (C31.3-4), which date from the early third century to early fourth century AD, are larger and have a longer, lenticular beaded lip, also with a smooth, red-slipped interior surface, akin to Bonifay's culinaire type 1 (A) type 1B.3-4 (Bonifay 2004: 211, fig. 112; Leitch 2010: 418, type 3.2.2). These casseroles were purposely produced along the eastern coast of north and central Tunisia for

<sup>10</sup> One rim fragment belonging to this form (FV1004) comes from a mixed context in Area IV of the Anglo-Tunisian excavations at Utica. The pottery from this area is currently being studied by the author.



a strong export market that extended throughout the entire western and central Mediterranean basin.

C31.1. BLB12/32/22: Rim, d. 28. Fabric: Pale red quartz fabric; burnished bright red/pink interior surface; pale brown smoothed exterior with grey patches and streaked use-wear. Source: North Tunisia. Context: Bulebel SU 32, Phase 2.

C31.2. BLB12/23/4: Shoulder profile, d. 15. Fabric: Fine pale red/brown fabric with fine quartz inclusions; unslipped pale red interior; pale red/brown smoothed exterior with black/grey soot patches. Context: Bulebel SU 23, Phase 2.

C31.3. FRM08/42/105: Rim, d. 32. Fabric: Red quartz fabric (Peacock fabric 2.1); bright red-slipped and burnished interior surface; exterior pale brown/grey streaky surface. Context: Foreman Street SU 42.

C31.4. MLT84/49733: Profile, rim (d. 28), base (d. 20). Fabric: Red quartz fabric; internal red slip; brown/black streaked exterior surface. Context: Melita SU 1101, Phase 5.

### C32. Hayes 193 (Figure 49)

Only a single rim sherd belonging to this form was identified within the Foreman Street assemblage, and it resembles the simple, curved-walled casserole, Hayes form 193/Bonifay *culinaire* (A) type 2. It dates from the first to third century AD (Hayes 1972: 207; Bonifay 2004: 211, fig. 112). Surfaces are unslipped, however, the exterior surface is fired black. A source in north Tunisia, in particular within the Carthage zone and Oudhna (*Uthina*) is suggested (Leitch 2010: 412, type 3.1.4).

C32.1. FRM08/42/103: Rim, d. 17. Fabric: Fine red quartz fabric (Peacock fabric 2.1); external surface fired black (Black-Topped ware?). Context: Foreman Street SU 42.

### C33. Hayes 183-4 variants (Figure 49)

Within this category are grouped a range of casserole variants commonly classified under the umbrella types Hayes 183 and 184. Within the Maltese assemblages no two sherds were exactly alike, however they each displayed a low, round body with a distinct everted rim. One variant (C33.1) can be compared with Bonifay's *culinaire* (B) type 7, variant C (Hayes form 184 and Sabratha form 59), which displays a flat-topped, quadrangular rim. This variant is dated to the second half of the second to third century AD, and is a product of the Sahel region of Tunisia (Hayes 1972: 203-204; Dore 1989: 128, fig. 34; Bonifay 2004: 217-219, fig. 116). Variant C33.2 is similar to Bonifay's *culinaire* type 15.3, where it is also probably a central Tunisian product and

similar in date to C33.1, although it can extend into the fourth century (Bonifay 2004: 227-229, fig. 122a).

No strong parallels could be found for the third variant (C33.3), possibly with the exception of Dore's rare form 55 from Sabratha. Even here, the Sabratha example has clearly ribbed exterior walls whilst the Maltese example does not (Dore 1989: 124-125, fig. 34). The fabric points towards a central Tunisian source, whilst the context is suggestive of a mid-third-century date onwards. The closest parallel for the final example (C33.4) is probably Dore's form 61 from Sabratha (Bonifay's *culinaire* (C) type 17.1), dated to about the third century AD (Dore 1989: 126-128, fig. 34; Bonifay 2004: 229, fig. 122a). Dore's form 37 is also similar, however, a first-century BC date is likely to be too early for the Maltese sherd (Dore 1989: 118, fig. 31). A southern Tunisian/Tripolitanian source for this particular form is possible. Aside from these examples, only two other Tripolitanian casserole variants from Sabratha have been recorded on the islands, and they come from the Ghar ix-Xiħ (Gozo) assemblage.

C33.1. FRM08/42/104: Rim, d. 18. Fabric: Fine red clay with fine quartz inclusions (Peacock fabric 2.1); unslipped, smoothed surfaces. Context: Foreman Street SU 42.

C33.2. MLT84/49730: Rim, d. 36. Fabric: Brick-red quartz fabric with large white lime inclusions (Peacock fabric 2.6); smooth black exterior. Context: Melita SU 1101, Phase 5.

C33.3. MLT84/49945: Rim, d. 19. Fabric: Orange/brown gritty quartz fabric with yellow lime and grey quartz-like inclusions; unslipped pale brown exterior surface. Context: Melita SU 1098, Phase 5.

C33.4. MLT84/49356: Rim, d. 28. Fabric: Coarse red fabric with large quartz and white lime inclusions; brown/black streaky exterior. Context: Melita SU 1093, Phase 4.

### C34. Hayes 197 (Figure 50)

This common Tunisian cooking vessel was recorded within the Foreman Street and later-phased Melita contexts. Twenty-one fragments of Hayes 197 casseroles were recorded and belong to the smaller beaded series that date to between the end of the second and fourth century AD (Hayes 1972: 209; Bonifay 2004: 225, fig. 120, *culinaire* (C) type 10). All the examples are made in North Tunisian fabrics, from the region of Byzacena. This form is one of the most commonly exported classic African forms found throughout the western and central Mediterranean. It is also possibly the most common African cooking ware form on the Maltese islands, where they have been recorded at the Żejtun

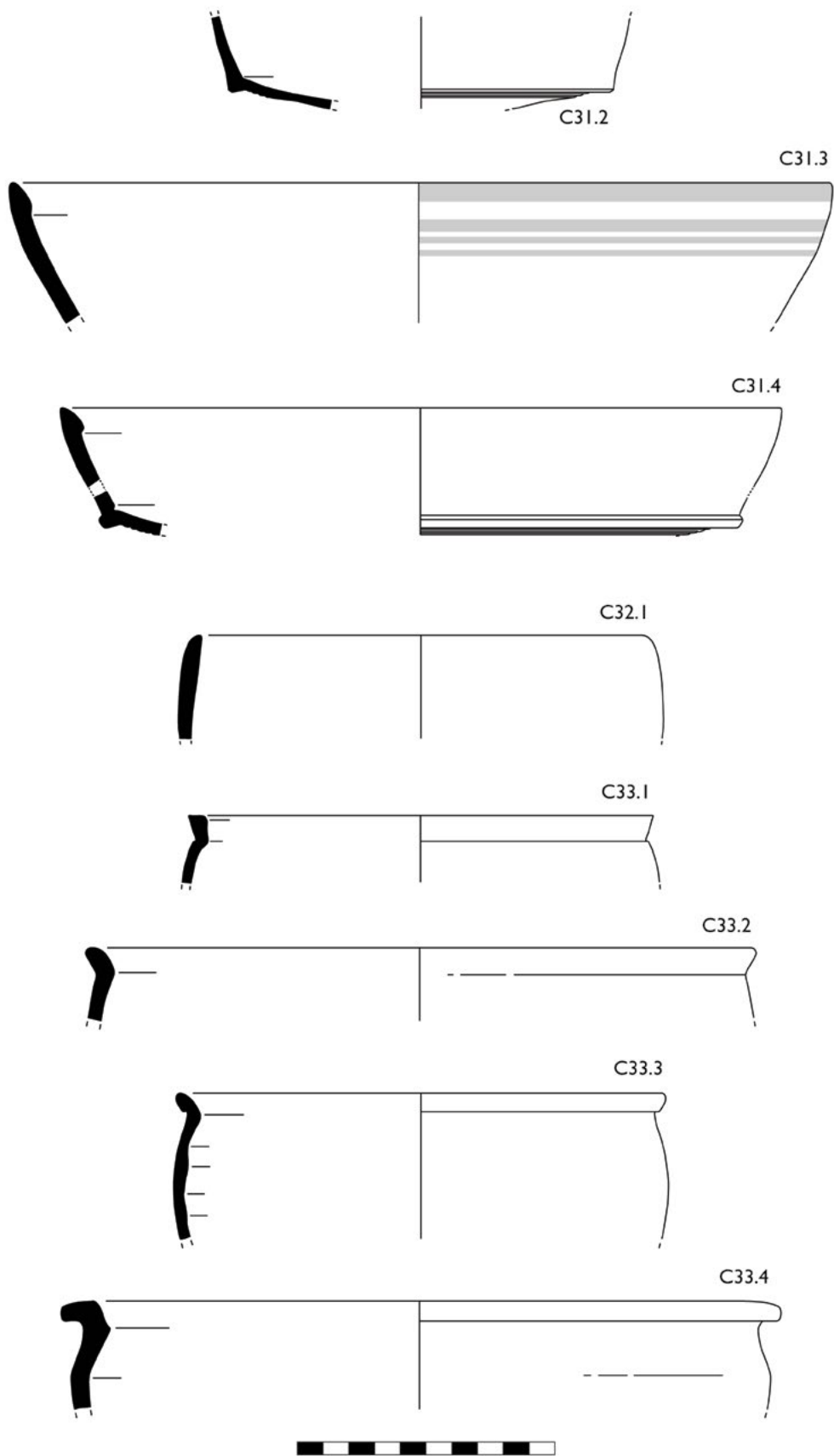

Figure 49: Imported cooking ware forms (C31-C33).

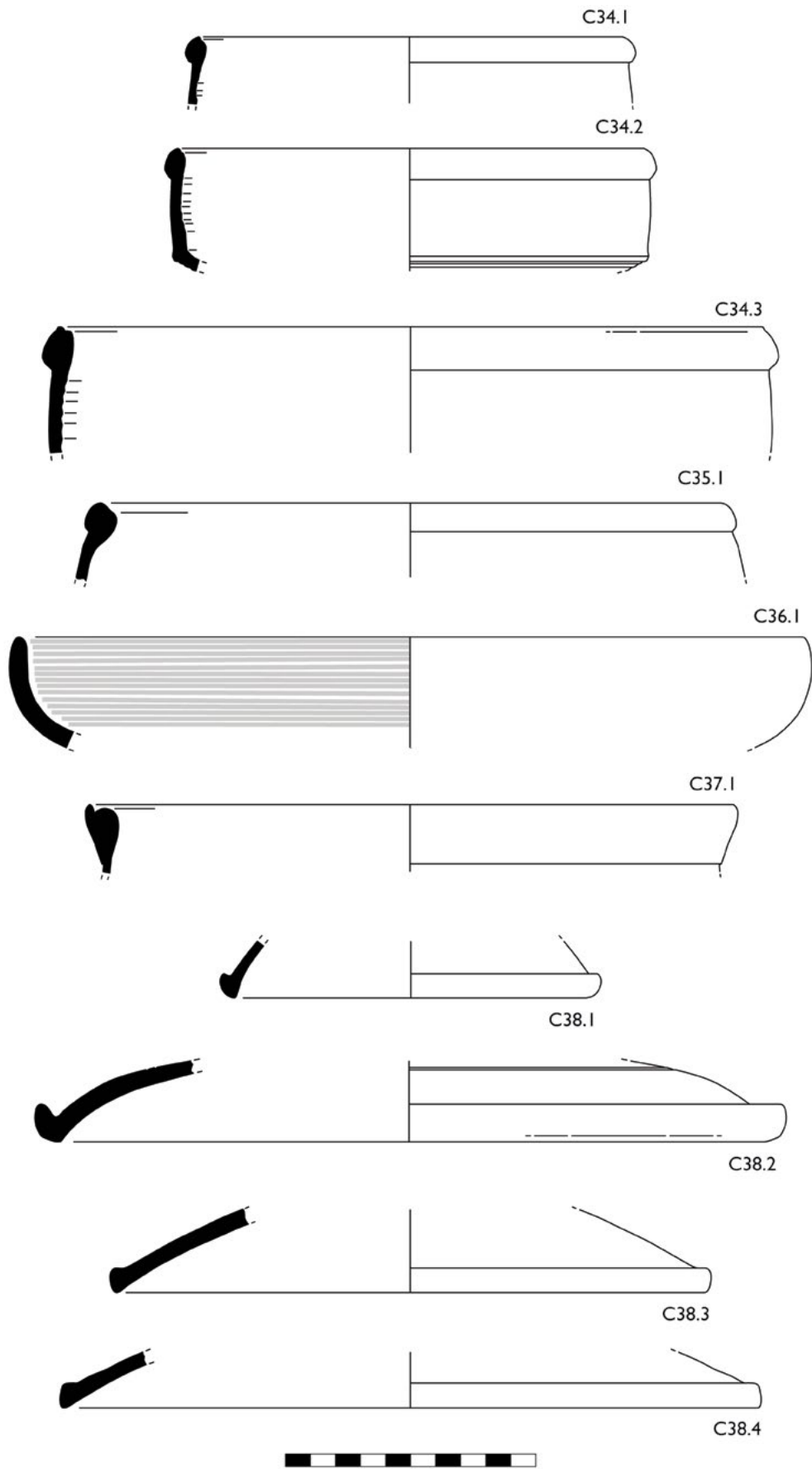

Figure 50: Imported cooking ware forms (C34-C38).

villa (Anastasi 2012: 35, fig. 5.48) and Tas-Silġ (Bozzi *et al.* 1968, fig. 4.18). The catalogued examples here are all from Foreman Street and display features that would suggest a chronological development (see each category entry below for further details).

C34.1. FRM08/42/102: Rim, d. 18. Fabric: Fine pale brown quartz fabric; unslipped. Source: North Tunisian. Type: Hayes 197; Bonifay culinaire type 10, no. 2. Date: End of the second century AD. Context: Foreman Street SU 42.

C34.2. FRM08/42/100: Rim, d. 18. Fabric: Fine red quartz fabric; unslipped. Source: North Tunisia. Type: Hayes 197, Bonifay culinaire type 10, nos 2-3. Date: Late second to third century AD. Context: Foreman Street SU 42.

C34.3. FRM08/42/101: Rim, d. 23. Fabric: Fine red quartz fabric; unslipped. Source: North Tunisia. Type: Hayes 197; Bonifay culinaire type 10, nos 6-7? Date: Beginning of the fourth century AD? Context: Foreman Street SU 42.

### C35. Hayes 197 variant? (Figure 50)

This North African form is characterised by an inward-curving thickened beaded rim, and is possibly one of the many variants of the Hayes 197 classic casserole. In her recent typology of North African cooking wares, Leitch classifies a similar vessel (Leitch type 4.2.3.5) and dates it to the third century AD (Leitch 2010: 438-439). The Maltese example lacks such a distinct groove on the top of the rim as is shown in the example from Pupput (Bonifay 2004: 233, fig. 125, no. 1). Alternatively, this example shares similarities with a slightly later-dated casserole – Bonifay’s culinaire type 26, no. 1 – dated to the end of the fourth century AD (Bonifay 2004: 234). Only a single example was recovered from the Melita assemblage in a later-dated context.

C35.1. MLT84/24733: Rim, d. 26. Fabric: Brick-red quartz fabric; blackened exterior. Source: North Tunisia. Type: Leitch type 4.2.3.5/Bonifay culinaire C type 24/Marmite Sidi Jdidi 2? Date: third century AD. Context: Melita SU 1062, Phase 4.

### C36. Hayes 181 (Figure 50)

This form belongs to a wide flat pan with low, slightly inward-curving walls and a simple rim. The interior surfaces are red-slipped and burnished, leaving a smooth, faceted finish. The form has a long development, appearing in the end of the first century and continuing into the early fifth century AD (Bonifay 2004: 213-214, figs 113-114, culinaire (B) type 5). All the examples identified within the Maltese assemblages come from the Melita excavations, and the

thicker, straighter walls are suggestive of Bonifay’s C/D variants, which are dated from the end of the second to the second half of the fourth-early fifth century AD (Bonifay 2004: 213, fig. 113). They are produced in the north/central coastal regions of Tunisia and are a very common African export to the central and western Mediterranean.

C36.1. MLT84/24076: Rim, d. 32. Fabric: Granular red clay with lots of fine quartz, and occasional fine white inclusions; burnished, smoothed red-slipped interior surfaces; unslipped pale brown exterior. Context: Melita SU 1059, Phase 6 (mixed context).

### C37. Bonifay culinaire type 31 (Figure 50)

Only one example of this casserole form was identified in the Melita assemblage and it came from a disturbed context. It is included here as a separate category in order to highlight its presence on the island. The form belongs to a Cape Bon production – Bonifay’s culinaire (C) type 31 – and has a thickened rim with a grooved top, thought to be a variant of a Hayes 197 casserole (see type C34) (Bonifay 2004: 239, fig. 128; Leitch 2010: 438, form 4.2.3.3). The form is dated to the end of the third and beginning of the fourth century AD, making it contemporary with the general dating of the Late Roman stratified levels at the Melita site (Phases 3-5). No published examples of this form are known on the Maltese islands.

C37.1. MLT84/24062: Rim, d. 26. Fabric: Gritty pale red clay with fine quartz inclusions; unslipped, grey/brown-coloured surfaces. Context: Melita SU 1059, Phase 6 (mixed context).

### North African cooking ware lids (C38-C43)

This section includes the many variants of North African lids that were recovered from the assemblages. North African cooking ware lids were amongst the most numerous imported cooking ware finds.

### C38. North African hooked rims (Figure 50)

This group of North African lids includes all lids with a hooked (C38.1-2) or bevelled/beaded rim (C38-4). Each entry includes all the details related to the type, source and date for the lid types illustrated here.

C38.1. FRM08/59/35: Rim, d. 14. Fabric: Red quartz fabric (Peacock fabric 2.1); unslipped. Source: North Tunisia. Type: Hayes 195 variant. Date: second to third century AD? Context: Foreman Street SU 59.

C38.2. MLT84/26182: Rim, d. 30. Fabric: Brick-red quartz fabric; Black-Topped ware (Bonifay’s catégorie A/C). Source: North Tunisia. Type: Classic Hayes 195/

Bonifay culinaire type 12. Date: End of the fourth to first half of the fifth century AD. Context: Melita SU 1099, Phase 5.

C38.3. MLT84/49475: Rim, d. 24. Fabric: Brick-red quartz fabric; pale brown streaky exterior surface. Source: North Tunisia. Type: Hayes 185 variant/Bonifay culinaire 9B. Date: End of the second to mid-third century AD, possibly earlier? Context: Melita SU 1095, Phase 2.

C38.4. MLT84/49495: Rim, d. 28. Fabric: Brown/red quartz fabric; unslipped; blackened rim from use-wear. Source: North Tunisia. Type: Hayes 185 variant/Bonifay culinaire 9B. Date: End of the second to mid-third century AD, possibly earlier? Context: Melita SU 1095, Phase 2.

### C39. North African bevelled lids (Figure 51)

This group categorises North African lids that have straight walls and simple squared rims. These forms are often associated with early Roman North African lids such as variants of Hayes 185 (Bonifay culinaire type 9C) and later Hayes 196 versions.

C39.1. BLB12/28/5: Rim, d. 26. Fabric: Brick-red quartz fabric with fine black and grey inclusions; Black-Topped ware. Source: North Tunisia? Type: Hayes 185 variant (Bonifay culinaire type 9C no. 7)/Fulford 1994, type 14. Date: Second half of the first to the early-to-mid second century AD (Fulford 1994: 66); end of the second to mid-third century AD? (Bonifay 2004: 221) Context: Bulebel SU 28, Phase 2.

C39.2. FRM08/42/114: Rim, d. 20. Fabric: Red quartz fabric; unslipped. Source: North Tunisia. Type: Hayes 185 variant (Bonifay culinaire type 9C no. 7). Date: End of the second to mid-third century AD (Bonifay 2004: 221). Context: Foreman Street SU 42.

C39.3. FRM08/42/115: Rim, d. 19. Fabric: Red quartz fabric; unslipped. Source: North Tunisia. Type: Hayes 185 variant (Bonifay culinaire type 9C no. 7). Date: End of the second to mid-third century AD (Bonifay 2004: 221). Context: Foreman Street SU 42.

C39.4. FRM08/42/120: Rim, d. 22. Fabric: Red quartz fabric; unslipped. Source: North Tunisia. Type: Hayes 185 variant (Bonifay culinaire type 9C no. 7). Date: End of the second to mid-third century AD (Bonifay 2004: 221). Context: Foreman Street SU 42.

C39.5. FRM08/42/116: Rim, d. 26. Fabric: Red quartz fabric; unslipped. Source: North Tunisia. Type: Hayes 185 variant (Bonifay culinaire type 9C no. 7). Date: End of the second to mid-third century AD (Bonifay 2004: 221). Context: Foreman Street SU 42.

### C40. North African Hayes 196 lid (Figures 51 and 52)

This North African lid form is characterised by a thickened rim edge common in Hayes 196 forms. The first variants (C40.1-3) have an indistinct, inward-curving, thickened rim and are comparable to Bonifay's culinaire type 11. This variant belongs to a common North Tunisian series and is dated to the late second to mid-third century AD (Bonifay 2004: 221). Example C40.4 probably belongs to a slightly earlier Carthaginian version, datable to the early to mid-second century AD. The last two examples (C40.5-6) are also North Tunisian Hayes 196 variants, which find their closest similarity to Leitch's classification type 1.2.1.2. These were produced from the early second to the fifth century AD, although they were mostly common during the fourth century AD (Leitch 2010: 378). For these examples, however, a date until at least the mid-third century is suggested by the Foreman Street context.

C40.1. FRM08/59/33: Rim, d. 20. Fabric: Red clay with fine quartz inclusions; unslipped. Context: Foreman Street SU 59.

C40.2. FRM08/59/32: Rim, d. 24. Fabric: Red clay with fine quartz inclusions; Black-Topped ware. Context: Foreman Street SU 59.

C40.3. FRM08/42/117: Rim, d. 26. Fabric: Red clay with fine quartz inclusions; Black-Topped ware. Context: Foreman Street SU 42.

C40.4. MLT84/49476: Rim, d. 26. Fabric: Red quartz fabric; unslipped. Context: Melita SU 1095, Phase 2.

C40.5. FRM08/42/118: Rim, d. 26. Fabric: Red quartz fabric; unslipped; blackened rim exterior due to use-wear. Context: Foreman Street SU 42.

C40.6. MLT84/26194: Rim, d. 26. Fabric: Red quartz fabric; unslipped. Context: Melita SU 1099, Phase 5.

### C41. Fulford lid type 11.5 (Figure 52)

This lid form is a North Tunisian production and can be compared with Fulford's lid type 11.5, which has been dated from the second to third century, but could continue well into the fifth century AD (Fulford 1984: 191, type 11.5). Only a single example was identified within these new assemblages, whilst no other Maltese examples have been recorded to date.

C41.1. FRM08/42/119: Rim, d. 26. Fabric: Brown quartz fabric; unslipped. Context: Foreman Street SU 42.

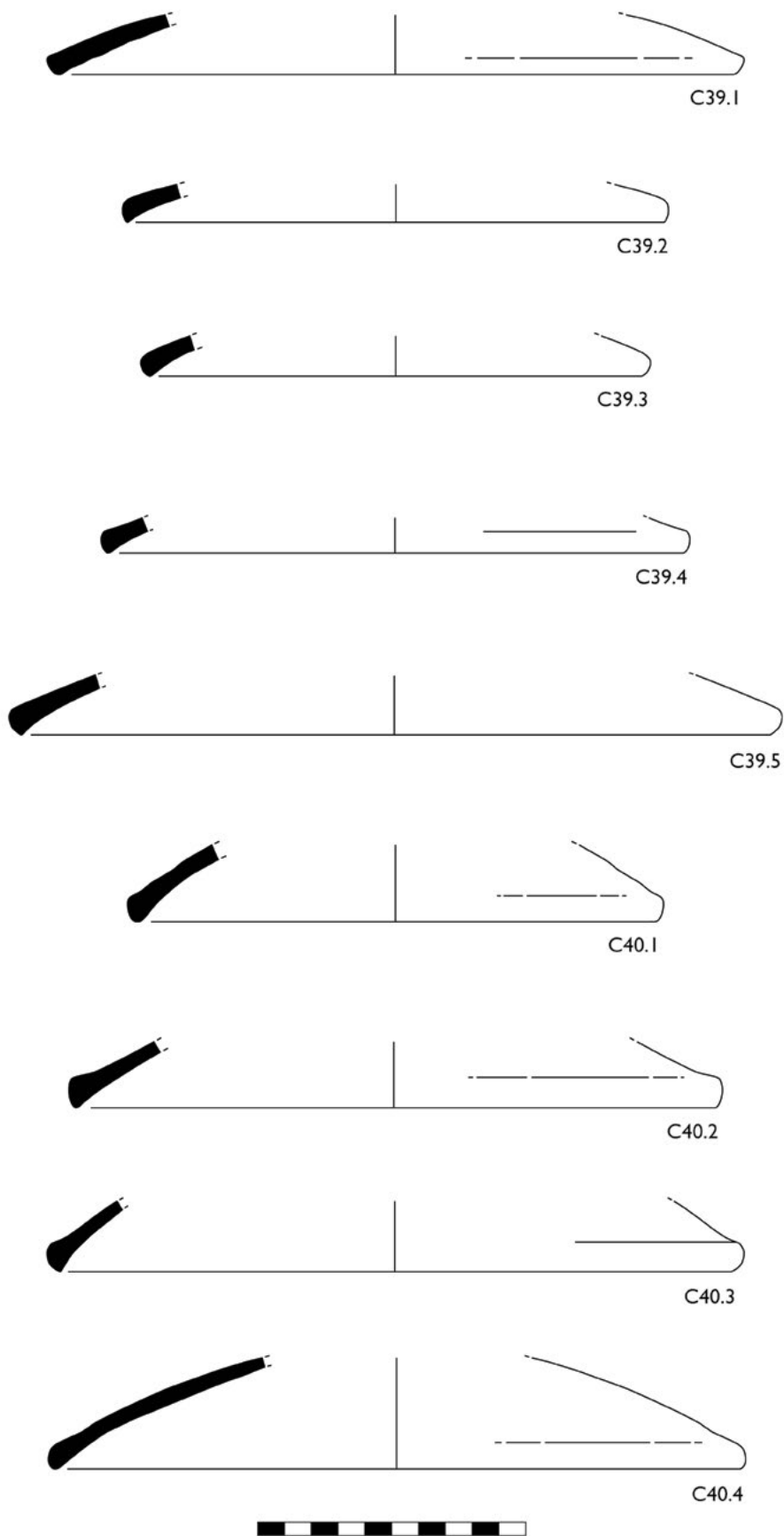

Figure 51: Imported cooking ware forms (C39-C40).

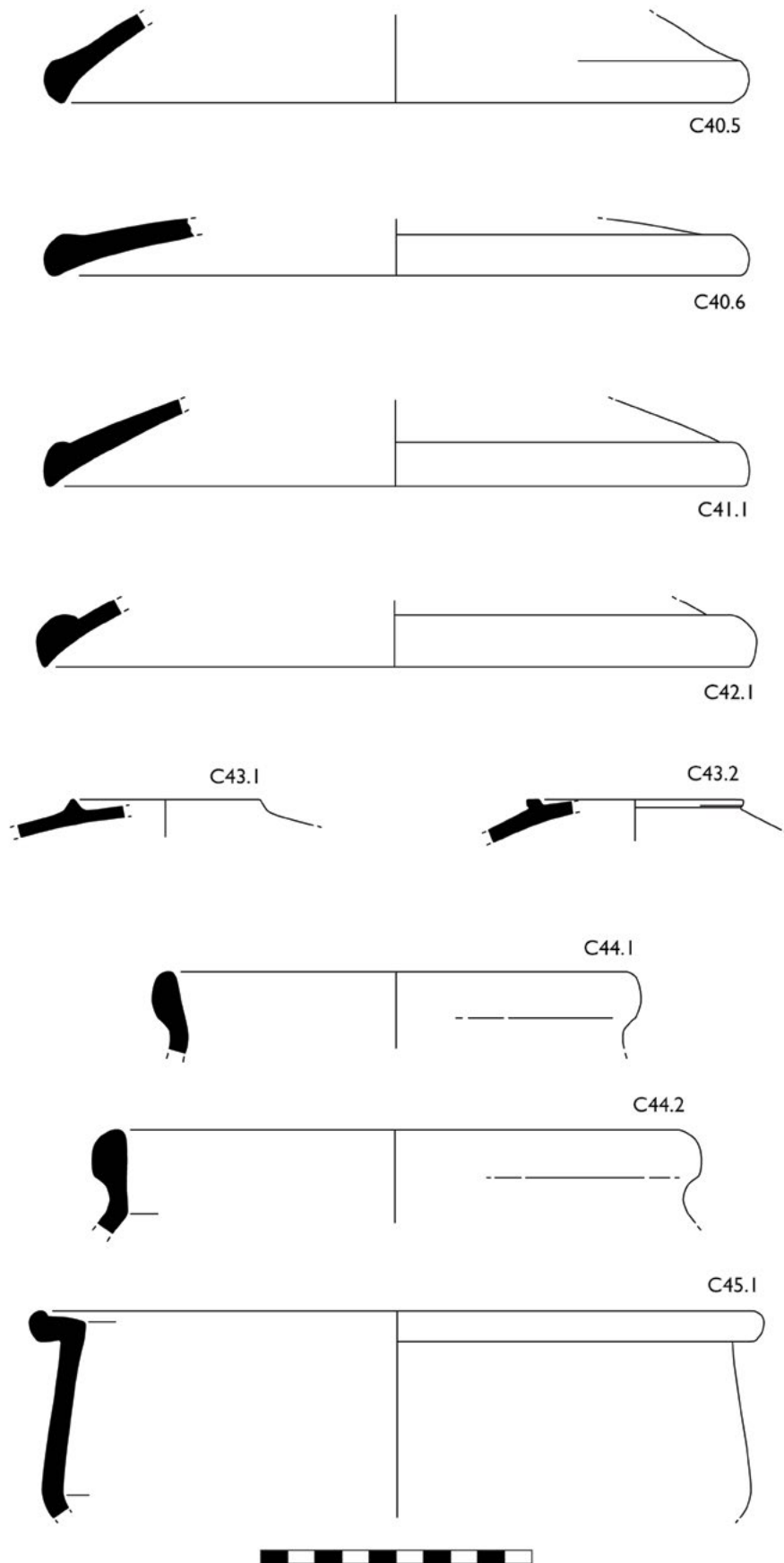

Figure 52: Imported cooking ware forms (C40-C45).

**C42. Fulford lid type 14 (Figure 52)**

This North Tunisian form can be compared with Fulford's lid type 14 (from Carthage), Dore's type 104 (from Sabratha) and Leitch's form 1.2.3.1 (Fulford 1984: 193, type 14; Dore 1989: 153-4, fig. 41; Leitch 2010: 382). It dates from the second half of the first to the third century AD, making it contemporary with the remaining pottery from the Foreman Street assemblage. A similar lid was also recovered from the small rural site of Ghar ix-Xiħ, also in Gozo (Anastasi and Quercia 2008-2009, fig. 13.2, find no. GRX05/120/12).

C42.1. FRM08/59/34: Rim, d. 26. Fabric: Red quartz fabric; unslipped. Context: Foreman Street SU 59.

**C43. Miscellaneous lids (Figure 52)**

These two sherds most probably belong to ring 'knobs' for cooking ware lids similar to those of Hayes 191 and Hayes 196 (Hayes 1972: 206). As there are no rims associated with either it remains difficult to be more specific.

C43.1. FRM08/42/107: Ring knob, d. 7. Fabric: Red quartz fabric; red slipped surfaces; possible ARS fabric? Source: North Tunisia. Type: Unknown. Date: second to fourth/fifth century AD? Context: Foreman Street SU 42.

C43.2. FRM08/42/108: Ring knob, d. 8. Fabric: Red quartz fabric; unslipped. Source: North Tunisia. Type: Hayes 192? Many similar shaped sherds associated with lids of Hayes type 192 have been identified and recorded from the recent Early Imperial excavations at Utica, Tunisia.<sup>11</sup> Date: first to third century AD? Context: Foreman Street SU 42.

*Pantellerian ware (C44-C51)*

This type of imported cooking ware was most common in the Foreman Street assemblage, making up 41% of the cooking wares, whilst it made up about 14% of the Melita cooking ware assemblage. Pantellerian ware has been recorded on several Maltese and Gozitan sites including the Punic sanctuary of Tas-Silġ (Quercia 2006), the rural site of Ghar ix-Xiħ, Gozo (Quercia and Anastasi 2008-2009) and the Žejtun villa (Anastasi 2010; 2012).

**C44. Scauri type 7.3/Sabratha types 291-292 (Figure 52)**

This olla form was only identified at Foreman Street and is characterised by a round-bodied vessel with an

almond-shaped rim. It belongs to Dore's forms 291-292 from Sabratha (Dore 1989: 219-220, fig. 61), and was also present within the Scauri wreck assemblage, classified as type 7.3 (Baldassari 2009: 103, tav. V). This form has been found in contexts dating from the first century BC to the second half of the second century AD in Sabratha, and to the third-fourth centuries in Agrigento, whilst Quercia identified this form in early contexts at Tas-Silġ (Dore 1989: 219-220; Baldassari 2009: 103; Quercia 2006: 1606). The Foreman Street context would suggest a date between the mid-second and early-mid-third century AD for this form, although more finds are needed to support this.

C44.1. FRM08/59/38: Rim, d. 18. Fabric: Dark grey/brown, gritty fabric with black sand and fine lime inclusions; unslipped. Context: Foreman Street SU 59.

C44.2. FRM08/59/39: Rim, d. 20. Fabric: Pale brown-to-pink, gritty fabric with black sand and fine lime inclusions; unslipped. Context: Foreman Street SU 59.

**C45. Pantellerian cooking pot type 1 (Figure 52)**

Very few parallels for this Pantellerian ware form have been identified in the literature, however, typologically it does appear to be similar to the North African cooking ware casserole Hayes 199. Only a single example was identified at Foreman Street (C45.1) and it is associated with a variety of other Pantellerian ware forms dating to the second to mid-third century AD.

C45.1. FRM08/42/84: Rim and body, d. 25. Fabric: Pale brown to grey gritty fabric with fine lime, quartz and some black volcanic inclusions; unslipped, dry-shaved surfaces. Context: Foreman Street SU 42.

**C46. Scauri types 3.1-2/Sabratha form 293 (Figure 53)**

This shallow pan with a pointed, triangular rim, is one of the most common Pantellerian forms recorded within all the assemblages. The form sees very little morphological developments throughout its production. At Sabratha (Dore's form 293) it was associated with contexts dating to the Late Republican period (Dore 1989: 220, fig. 63), whilst typologically similar vessels from Cosa are dated to the third century AD (Dyson 1976: 139-140). Its presence at Carthage extends well into the fifth century AD (Fulford 1984: 157, form 1). Thus the examples listed below could all be contemporary within their contexts: the Foreman Street sherds can be dated to about the end of the second to mid-third century AD, whilst the Melita fragments date to the mid-third-mid-fourth century. It is one of the most commonly exported Pantellerian

<sup>11</sup> This information is derived from on-going research by the author of the pottery from Area IV of the Anglo-Tunisian excavations at Utica, Tunisia.



ware forms found on most coastal sites in the central and western Mediterranean, and does occur in contexts as late as the seventh century (Baldassari 2009: 97, teglia type 3, tav. II).

C46.1. FRM08/42/82: Rim, d. 28. Fabric: Pantellerian ware - Coarse, gritty grey/brown clay with large angular black volcanic and translucent inclusions; unslipped, dry-shaved surfaces. Context: Foreman Street SU 42.

C46.2. FRM08/42/83: Rim, d. 28. Fabric: Pantellerian ware - coarse, gritty grey/brown clay with large angular black volcanic and translucent inclusions; unslipped, dry-shaved surfaces. Context: Foreman Street SU 42.

C46.3. FRM08/59/36: Rim, d. 29. Fabric: Pantellerian ware - coarse, gritty grey/brown clay with large angular black volcanic and translucent inclusions; unslipped, dry-shaved surfaces. Context: Foreman Street SU 59.

C46.4. MLT84/26940: Rim, d. 34. Fabric: Coarse grey to pale brown gritty fabric with fine lime, quartz and black volcanic inclusions; unslipped, dry-shaved surfaces. Context: Melita SU 1076, Phase 6 (mixed context).

C46.5. FRM08/57/19: Rim, d. 42. Fabric: Pantellerian ware - coarse, gritty grey/brown clay with large angular black volcanic and translucent inclusions; unslipped, dry-shaved surfaces. Context: Foreman Street SU 57.

#### C47. Scauri type 4.4 (Figure 53)

This category of Pantellerian ware casseroles includes wide-bodied pans with a straight and slightly everted wall with an elongated beaded grooved rim. Many variants have been identified, but collectively they belong to the Scauri type 4.4 and Guiducci's teglie M1-2 types, dateable to between the second and seventh centuries AD (Baldassari 2009: 97-102, tav. III; Guiducci 2003: 65, fig. 4). At least two well-known classified types are represented and from the concentration within the Melita contexts, they can be dated with some degree of certainty from the mid-third to mid-to-late fourth century AD. Maltese imitations of this form have been recorded within the same assemblage (see type C18).

C47.1. MLT84/49354: Rim, d. 44. Fabric: Coarse brown gritty fabric with fine white lime and black volcanic inclusions; unslipped, dry-shaved surfaces. Context: Melita SU 1093, Phase 4.

C47.2. MLT84/26937: Rim, d. 34. Fabric: Coarse brown gritty fabric with fine white lime and black volcanic

inclusions; unslipped, dry-shaved surfaces. Context: Melita SU 1076, Phase 6 (mixed context).

C47.3. MLT84/49645: Rim, d. 38. Fabric: Coarse pale brown/grey gritty fabric with white lime and black volcanic inclusions; unslipped, dry-shaved surfaces. Context: Melita SU 1103, Phase 5.

C47.4. MLT84/49929: Rim, d. 28. Fabric: Coarse grey/brown fabric with fine lime, quartz and black volcanic inclusions; unslipped, dry-shaved surfaces. Context: Melita SU 1098, Phase 5.

#### C48. Scauri type 4.6 (Figure 54)

This form is similar to the above form (type C47) but has a flatter and wider rim. R. Baldassari classified this form as Scauri form 4.6, but it was not at all common within the Scauri wreck assemblage. The same form was more common at Sabratha (form 296) and was dated to the first half of the third century AD (Baldassari 2009: 102, tav. III; Dore 1989: 221-223, fig. 61).

C48.1. MLT84/26938: Rim, d. 24. Fabric: Coarse grey/brown gritty fabric with fine white lime and black volcanic inclusions; unslipped, dry-shaved surfaces. Context: Melita SU 1076, Phase 6 (mixed context).

C48.2. MLT84/49910: Rim, d. 34. Fabric: Coarse grey/brown gritty fabric with fine white lime and black volcanic inclusions; unslipped, dry-shaved surfaces. Context: Melita SU 1085, Phase 3.

#### C49. Scauri lid type 1.3 (Figure 54)

This simple lid form is wide, has high sloping walls and ends with a distinct beaded rim. No complete examples were recovered from the Maltese assemblages so the form of the knob remains unknown. General classifications can be found with the Scauri lid type 1.3 and Fulford's handmade lid type 5 from the Carthage excavations (Baldassari 2009: 95, tav. I; Fulford 1984: 159). This lid form tends to be quite ubiquitous throughout the Roman period and has been associated with contexts at Scauri dating from the end of the fourth to beginning of the fifth century AD, and contexts dating to the beginning of the seventh century at Carthage. At least one knob fragment of the same lid type was recovered from the 1972 assemblage at the Žejtun villa (Anastasi 2012: 35, fig. 5.43).

C49.1. BLB12/65/3: Rim, d. 36. Fabric: Coarse pale brown fabric with angular/rough quartz and lime inclusions; unslipped. Context: Bulebel SU 65, Phase 2.

C49.2. MLT84/25219: Rim, d. 28. Fabric: Coarse brown fabric with quartz, white lime and black volcanic inclusions; unslipped. Context: Melita SU 1071: 5.

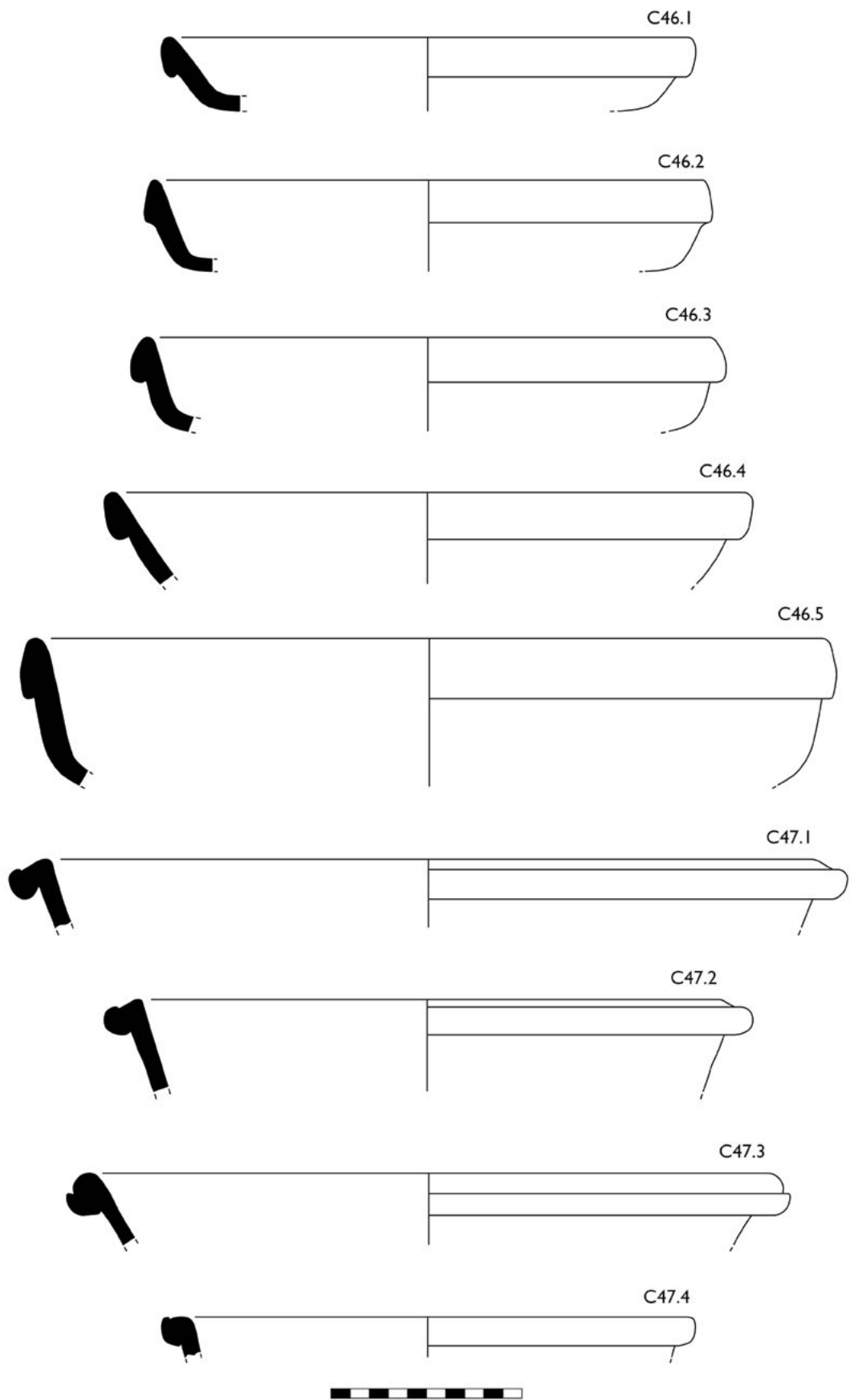

Figure 53: Pantellerian cooking ware forms (C46-C47).

C49.3. MLT84/49928: Rim, d. 34. Fabric: Coarse brown fabric with quartz, white lime and black volcanic inclusions; unslipped. Context: Melita SU 1098: 5.

#### C50. Scauri type 1.1-2/Fulford type 6 (Figure 54)

This lid form has a lower, sloping wall and a simpler, thinner rim edge. Only a single example was identified within the Foreman Street assemblage and can be compared with Fulford's handmade lid type 6 and Baldassari's Scauri type 1.1-2 (Baldassari 2009: 95, tav. I; Fulford 1984: 159). The chronological evidence for this form is like that of the previous type (type C49).

C50.1. FRM08/57/20: Rim, d. 26. Fabric: Coarse brown fabric with quartz, white lime and black volcanic inclusions; unslipped. Context: Foreman Street SU 57.

#### C51. Pantellerian lid type 1 (Figure 54)

This lid is characterised by a circular-section beaded rim and wide, low walls. Close parallels for this particular form could not be found, however it may be a variant of form C49. This lid form was only identified within the Foreman Street assemblage, therefore it could possibly be dated to the end of the second to early-mid-third century AD.

C51.1. FRM08/59/37: Rim, d. 34. Fabric: Coarse brown fabric with quartz, white lime and black volcanic inclusions; unslipped. Context: Foreman Street SU 59.

C51.2. FRM08/42/85: Rim, d. 40. Fabric: Coarse brown fabric with quartz, white lime and black volcanic inclusions; unslipped. Context: Foreman Street SU 42.

#### coarse wares (D1-D80)

##### *Local coarse wares (D1-D80)*

This class refers to a broad group of plain or utilitarian vessels usually associated with food preparation, domestic storage, eating and drinking.

*Open forms: bowls, plates and cups (D1-D31)*

#### D1. Coarse ware bowl type 1 (Figure 55)

These two bowl examples are characterised by straight walls ending in a simple pointed rim. The fabric and finish is typical of Late Punic Maltese pottery, in particular the thick and smoothed cream slip that coats the surfaces. The red-painted concentric bands along the rim of type D1.1 is an additional Punic characteristic for pottery dating to between the fifth and third century BC. The shapes are similar to those classified by Quercia for the pottery from the sanctuary

of Tas-Silġ, which he dates from the beginning of the fourth to the third centuries BC (Quercia 2011: 439, fig. 2.1-2). They are also found in funerary contexts of the same date. The painted example (D1.1) is most probably part of a local Punic kylix (Sagona kylix form III: 1) (Sagona 2002: 198).

D1.1. FRM08/59/23: Rim, d. 22. Local Fabric 1: Orange clay with a pale grey core with white lime and fine foraminifera inclusions; thick and smoothed cream-coloured slip with red-painted bands on interior and exterior part of the rim. Context: Foreman Street SU 59; residual.

D1.2. FRM08/42/31: Rim, d. 16. Local Fabric 1: Orange fabric with a grey core with yellow lime and foraminifera inclusions; cream-slipped surfaces. Context: Foreman Street SU 42; residual.

#### D2. Coarse ware bowl type 2 (Figure 55)

This bowl form, with a bulbous rim, is common in Punic funerary contexts and within votive layers at the Punic sanctuary of Tas-Silġ, where it featured within Quercia's classification of Punic coarse pottery at the site (Quercia 2011, fig. 2.4). The fabric and surface treatment for this type are like the previous form except that no red-painted decoration has been recorded on this type. The chronology for this form is also similar to the previous type, between the fifth and third century BC (Quercia 2011: 441). Similar bowl rims have also been found in sealed first century BC contexts from the Żejtun villa site (Vella *et al.* 2017: 135, fig. 10.10).

D2.1. BLB12/30/2: Rim, d. 16. Local Fabric 1: Coarse orange fabric with white and yellow lime inclusions; thick cream-slipped surfaces. Context: Bulebel SU 30, Phase 2; residual?

#### D3. Coarse ware bowl type 3 (Figure 55)

This bowl form belongs to the same general bowl repertoire as the previous forms and is characterised by an inward-curving rim typical of the Hellenistic period, dated to between the fourth and third century BC (Quercia 2011, fig. 2.5). Many variants of this form were recovered from the excavations at Ġħar ix-Xiħ, Gozo (Quercia and Anastasi 2008-2009, fig. 3: 10-11, 18-21). Earlier variants of this type are characterised by a thick, cream-slipped finish, whilst later versions, like D3.3, tend to display rougher, unslipped surfaces like those from the Ġħar ix-Xiħ contexts that date to after the third century BC.

D3.1. FRM08/42/18: Rim, d. 12. Local Fabric 1: Soft pale brown clay with a grey core with white lime and fine red and grey inclusions; thick, smooth cream slipped surfaces. Context: Foreman Street SU 42; residual.

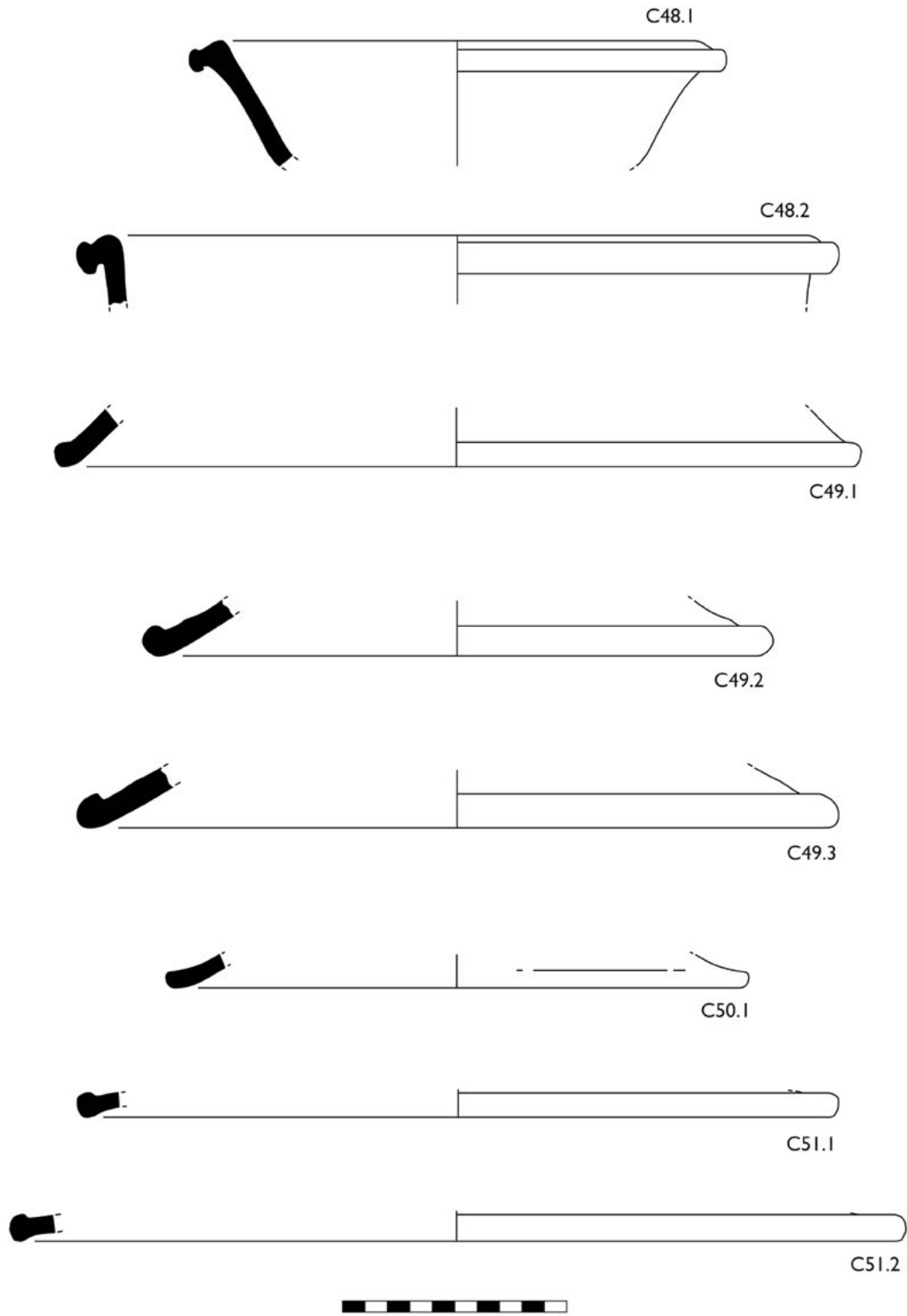

Figure 54: Pantellerian cooking ware forms (C48-C51).

D3.2. MLT84/49416: Rim, d. 16. Local Fabric 1: Pale orange clay with white lime inclusions; smoothed cream-slipped surfaces. Context: Melita SU 1091, Phase 2; residual?

D3.3. MLT84/49343: Rim, d. 18. Local Fabric 1: Coarse pale orange fabric with abundant lime inclusions; unslipped surfaces. Context: Melita SU 1093, Phase 4; residual.

#### D4. Coarse ware bowl type 4 (Figure 55)

This bowl shape is loosely characterised by a straight and short carinated rim. Variant **D4.1** shares morphological traits with a Punic form recorded in several tomb contexts on Malta and within votive contexts at the Punic sanctuary of Tas-Silġ. In this example, the fabric is typical of sixth/fifth-century BC local pottery – coarse grey, lime-rich clay – with a rough, unslipped finish (Sagona 2002: 175, bowl form III: 1). The second variant, **D4.2**, is thinner and appears to be later dated, based on the composition of the fabric and the thinness of the walls, which share morphological characteristics with the red-slipped versions seen within the same assemblage and Phase (see type **B4**). It is classified by Sagona as bowl form V: 2a, and it is common in funerary contexts dating to the early Roman period (Sagona 2002: 182-183).

D4.1. BLB12/58/40: Rim, d. 20. Local Fabric 1: Coarse grey fabric, fired pale brown towards the surfaces with large yellow lime inclusions; unslipped. Context: Bulebel SU 58, Phase 1; residual?

D4.2. BLB12/32/24: Rim, d. 16. Local Fabric 2: Pale red clay with white lime and black glauconite inclusions; unslipped, dark grey exterior; over-fired? Context: Bulebel SU 32, Phase 2.

#### D5. Coarse ware bowl type 5 (Sagona bowl form V: 4) (Figure 55)

This small cup is common in early Roman tomb contexts in Malta. Sagona recorded the form (bowl form V:4) in tombs associated with late first century BC to mid-first century AD-dated material and the shape has been found unslipped, as well as coated in a thin red slip (Sagona 2002: 183-184). The small cup has a flat, string-cut base with a sharp carinated wall ending in a simple flared rim. Earlier versions dating to around a century earlier (Sagona bowl form IV-V: 3b) are practically the same shape except for a smoothed disc or ring base (Sagona 2002: 180). A red-slipped example was recorded at Foreman Street (see type **B8**).

D5.1. BLB12/39/1: Profile, rim (d. 12), base (d. 3). Local Fabric 2: Pale brown clay with abundant glauconite

inclusions; unslipped. Context: Bulebel SU 39, Phase 2.

D5.2. BLB12/24/8: Rim, d. 12. Local Fabric 2: Pale orange clay with glauconite inclusions; unslipped. Context: Bulebel SU 24, Phase 2.

D5.3. BLB12/48/3: Rim, d. 12. Local Fabric 2: Pale orange clay with glauconite inclusions; unslipped. Context: Bulebel SU 48.

D5.4. BLB12/28/4: Profile, rim (d. 10), base (d. 3). Local Fabric 1: Pale grey clay with white/yellow lime inclusions; rough, cream surface colour/scum; flat, string-cut base. Context: Bulebel SU 28, Phase 2.

D5.5. BLB12/44/1: Rim, d. 13. Local Fabric 2: Pale orange/brown clay with glauconite inclusions; unslipped. Context: Bulebel SU 44, Phase 2.

D5.6. BLB12/32/18: Rim, d. 12. Local Fabric 2: Dark orange clay with glauconite inclusions; unslipped. Context: Bulebel SU 44, Phase 2.

D5.7. BLB12/24/7: Rim, d. 13. Local Fabric 2: Pale orange/brown clay with glauconite inclusions; unslipped. Context: Bulebel SU 24, Phase 2.

D5.8. BLB12/58/36: Rim, d. 16. Local Fabric 1: Pale orange fabric with lime and red, grog-like inclusions; unslipped. Context: Bulebel SU 58, Phase 1.

#### D6. Coarse ware bowl type 6 (Quercia bowl type 7: 7/ Sagona bowl form IV: 4a) (Figure 56)

This category includes a type of bowl characterised by a hemispherical body, with a thickened and slightly flaring rim. This bowl is very common on Maltese sites, dating from the third century BC until the first century AD. Local Fabric 1 is used for the bowls from Tas-Silġ and the Żejtun villa, and have been classified by Quercia as type 7 (Quercia 2011: 441-442, fig. 2.6-8). These bowls are always unslipped and wet-wiped, giving the surface a rough texture marred by finger-impressions and uneven firing. Associated bases are flat and string-cut. One example (**D6.1**) appears to be a third-second century BC form from Gozo and shares both its shape and fabric with examples from Ġħar ix-Xiħ (Quercia and Anastasi 2008-2009, fig. 3.3). A larger variant has been identified with **D46.1**.

D6.1. FRM08/59/22: Rim, d. 18. Local Fabric 1: Pale brown fabric with fine lime inclusions; unslipped. Context: Foreman Street SU 59; residual?

D6.2. BLB12/39/9: Rim, d. 12. Local Fabric 3: Hard orange fabric with lime, black glauconite and dark,

gritty (black sand?) inclusions. Context: Bulebel SU 39, Phase 2.

D6.3. BLB12/58/24: Rim, d. 14. Local Fabric 1: Hard, pale orange clay with lime inclusions; unslipped. Context: Bulebel SU 58, Phase 1.

D6.4. BLB12/55/13: Rim, d. 15. Local Fabric 1: Hard, pale orange clay with lime inclusions; unslipped. Context: Bulebel SU 55, Phase 1.

D6.5. BLB12/54/4: Rim, d. 17. Local Fabric 1: Hard, pale orange fabric with lots of lime and grog inclusions; unslipped. Context: Bulebel SU 54, Phase 1.

D6.6. FRM08/42/19: Profile, d. 11.5 (rim), d. 5 (base). Local Fabric 2: Hard, pale red fabric with white foraminifera, lime and black glauconite inclusions; unslipped dark grey-fired surfaces. Context: Foreman Street SU 42.

**D7. Coarse ware bowl type 7 (Figure 56)**

This bowl appears to be a later development of the previous form characterised by straighter, thinner walls and more angular rims.<sup>12</sup> Generally, Local Fabrics 2 and 3 are more commonly employed in these thinner versions. Although this form is found together with the earlier versions (see type D6), the fabrics do indicate that their production continues beyond that of the earlier type, at least into the first century AD, but better stratified material is required to clarify this.

D7.1. BLB12/58/26: Profile, d. 14 (rim), d. 5 (base). Local Fabric 2: Pale red fabric with fine lime and glauconite inclusions; unslipped. Context: Bulebel SU 58, Phase 1.

D7.2. BLB12/39/12: Profile, d. 13 (rim), d. 5 (base). Local Fabric 1: Pale brown fabric with white lime inclusions; unslipped. Context: Bulebel SU 39, Phase 2.

D7.3. MLT84/23208.1: Profile, d. 20 (rim), d. 8 (base). Local Fabric 3: Pale red fabric with black volcanic (?), gypsum, white lime and quartz inclusions; unslipped. Context: Melita SU 1022.

**D8. Coarse ware bowl type 8 (Sagona bowl form VI: 4b) (Figure 56)**

This bowl is characterised by straight everted walls, slightly carinated towards the ring base. Only two examples of this bowl were recorded and are restricted to Phase 1 at Bulebel giving a date of no later than the end of the first century. The same bowl has been classified by Sagona as

bowl form VI: 4b, common in tomb contexts, and dated to after the mid-first century (Sagona 2002: 188).

D8.1. BLB12/55/14: Rim, d. 20. Local Fabric 2: Well-fired dark orange fabric with black glauconite and fine lime inclusions; unslipped, well-finished surfaces. Context: Bulebel SUs 55 and 58, Phase 1.

D8.2. BLB12/58/4: Profile, d. 18 (rim), d. 6 (ring base). Local Fabric 2: Dark orange fabric with fine lime and black glauconite inclusions; unslipped, well-finished surfaces. Context: Bulebel SU 55, Phase 1.

**D9. Coarse ware bowl type 9 (Figures 56 and 57)**

This form is characterised by a simple hemispherical shape with thin walls leading to slightly flaring rims. Compared to the previous bowl types, the walls tend to be more vertically angled. This type was found exclusively at Foreman Street in Local Fabric 2. No parallels are known but three waster sherds strongly indicate that this form was manufactured within the vicinity of the Foreman Street site. Based on the context, the form can be dated to the end of the second to mid-third century.

D9.1. FRM08/42/23: Rim, d. 14. Local Fabric 2: Hard pale brown/pink fabric with fine white lime, foraminifera, black glauconite, some fine quartz/gypsum and larger red ore grain inclusions; unslipped pale surfaces. Context: Foreman Street SU 42.

D9.2. FRM08/42/24: Rim, d. 14. Local Fabric 2: Hard pale red fabric with fine foraminifera, lime and black glauconite inclusions; unslipped, white exterior skin. Context: Foreman Street SU 42.

D9.3. FRM08/42/20: Rim, d. 13. Local Fabric 2: Hard pale red fabric with fine white foraminifera, lime, black glauconite and translucent quartz or gypsum inclusions; unslipped pale yellow skin. Context: Foreman Street SU 42.

D9.4. FRM08/42/44: Rim, d. 10. Local Fabric 2: Gritty and hard red and grey fabric with white foraminifera and round, black glauconite inclusions; unslipped pale brown/grey surfaces. Context: Foreman Street SU 42.

D9.5. FRM08/57/16: Rim, d. 12. Local Fabric 2: Hard pale red fabric with lots of yellow lime halos, white foraminifera, glauconite and red ore inclusions; unslipped dark grey-fired exterior surfaces; waster. Context: Foreman Street SU 57.

D9.6. FRM08/57/14: Rim, d. 12. Local Fabric 2: Hard dark grey fabric with fine white lime, foraminifera, glauconite and some angular quartz/gypsum

<sup>12</sup> In terms of shape, close parallels can be sought with Quercia 2011, fig. 2.8, although little detail regarding context and fabric is currently available.

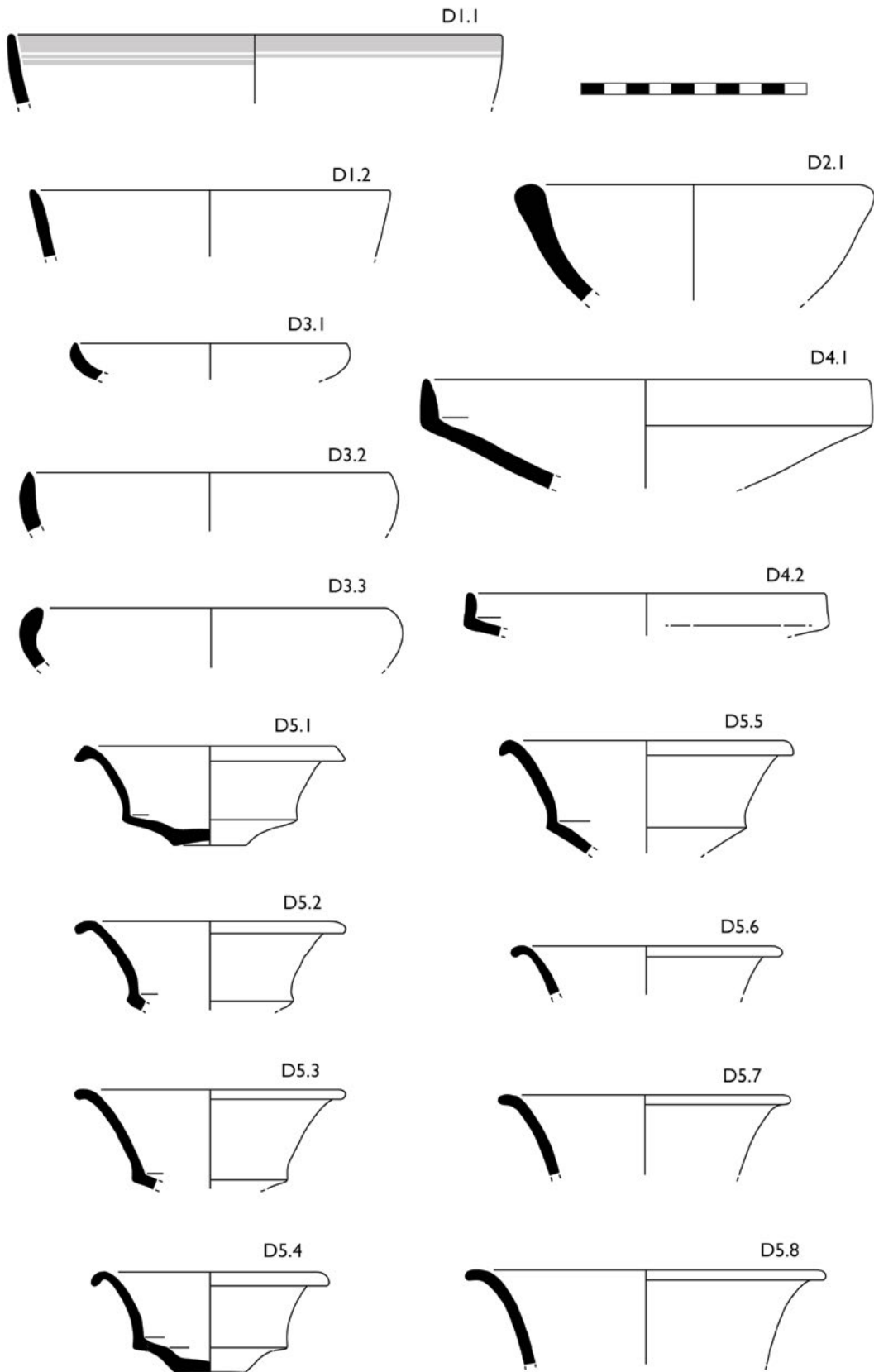

Figure 55: Local coarse ware bowls, types D1-D5.

inclusions; over-fired, unslipped grey surfaces; waster. Context: Foreman Street SU 57.

D9.7. FRM08/42/21: Rim, d. 11. Local Fabric 2: Hard pale red to grey fabric with fine yellow and white lime, foraminifera, and black and red glauconite inclusions; unslipped, grey surfaces. Foreman Street SU 42.

D9.8. FRM08/42/22: Rim, d. 15. Local Fabric 2: Pale brown fabric with large white lime, foraminifera, fine black glauconite, and some fine angular gypsum inclusions; unslipped pale surfaces. Context: Foreman Street SU 42.

D9.9. FRM08/57/15: Rim, d. 16. Local Fabric 2: Gritty pale grey fabric with lots of fine yellow lime, white foraminifera, and black and red glauconite inclusions; unslipped grey surfaces; waster. Context: Foreman Street SU 57.

D9.10. FRM08/42/28: Rim, d. 15. Local Fabric 2: Hard-fired, red fabric with fine white lime, foraminifera, and red and black shiny glauconite inclusions; pale cream surfaces; defective, warped rim; waster? Context: Foreman Street SU 42.

D9.11. FRM08/42/27: Rim, d. 21. Local Fabric 2: Hard-fired, red fabric with fine white lime, foraminifera, and red and black shiny glauconite inclusions; pale grey surfaces. Context: Foreman Street SU 42.

#### D10. Coarse ware bowl type 10 (Figure 57)

This bowl form is an unslipped, coarse ware version of the local red-slipped type B5. The form, fabric and date are generally the same as the red-slipped version.

D10.1. FRM08/42/42: Rim, d. 12. Local Fabric 2: Hard, gritty pale red fabric with large white lime, fine foraminifera, fine black glauconite and some angular gypsum inclusions; unslipped pale cream surface. Context: Foreman Street SU 42.

D10.2. FRM08/59/8: Rim, d. 13. Local Fabric 2: Pale brown/pink fabric with few fine foraminifera, fine black glauconite and red ore inclusions; unslipped surfaces. Context: Foreman Street SU 59.

D10.3. FRM08/42/38: Profile, d. 11 (rim), d. 5 (base). Local Fabric 2: Coarse pale brown fabric with large dark grey grog (?), fine black glauconite, and fine foraminifera inclusions; unslipped pale surfaces. Context: Foreman Street SU 42.

D10.4. FRM08/59/9: Profile, d. 11 (rim), d. 5 (base). Local Fabric 2: Hard-fired grey to red fabric with shiny

black glauconite, fine white lime, and foraminifera inclusions. Context: Foreman Street SU 59.

D10.5. FRM08/42/39: Rim, d. 16. Local Fabric 2: Pale brown fabric with fine black glauconite, fine white foraminifera, white lime and few large pale red grog inclusions; unslipped. Context: Foreman Street SU 42.

D10.6. FRM08/57/13: Rim, d. 12. Local Fabric 2 (Figure 22): Pale brown/pink fabric with fine, shiny black glauconite inclusions, fine white foraminifera and lime inclusions; unslipped. Context: Foreman Street SU 57.

D10.7. FRM08/42/135: Rim, d. 18. Local Fabric 2: Hard red fabric with white lime, foraminifera, and black glauconite inclusions; pale yellow exterior surface. Context: Foreman Street SU 42.

D10.8. FRM08/57/31: Base, d. 6. Local Fabric 2: Hard-fired red and grey fabric with streaks of yellow clay or foraminifera (?); contains fine black glauconite inclusions; unslipped pale grey surfaces. Context: Foreman Street SU 57.

#### D11. Coarse ware bowl type 11 (Figure 58)

This shape is a carinated, thin-walled, bowl form with a diameter range between 13 and 18 cm. The slightly concave rim flares sharply outwards creating a Z-shaped profile. The vessels are not very well-finished, remain unslipped and only lightly wet-wiped with a bloom or salt-slip that coats an uneven rough surface. One example was found to contain a finger-impressed flat, horizontal strap handle flush with the rim (D11.4). Several wasters displaying blistering, over- and under-firing and warped walls and rims were noted and attest to the high probability that this form was manufactured at or near the Foreman Street site, where all the examples identified were recovered. Close parallels for this shape are not widely known, however, bowls discovered in a rock-cut tomb near Wied il-Għasri, Gozo in 1979 are likely to be similar in shape (Sagona 2002: 1124-1126, figs 248.4-6, 249.23-25; Figure 77). Sagona has classed this form as bowl form V: 3 (Sagona 2002: 183, fig. 348.31). All the forms identified are made using a hard-fired red fabric containing fine black glauconite inclusions and white lime (Local Fabric 2). This type of fabric and form was also noted in the examples noted by Sagona in her study of Punic pottery in the Maltese islands and may be indicative of the possible export of Gozitan vessels to the neighbouring island of Malta (Sagona 2002: 1059, nos. 49-50). No complete profiles or bases have been identified for this form. This form, together with bowl type D12, shares some characteristics with a funnel vessel identified by Rotroff. However, no spouts characteristic of the funnel



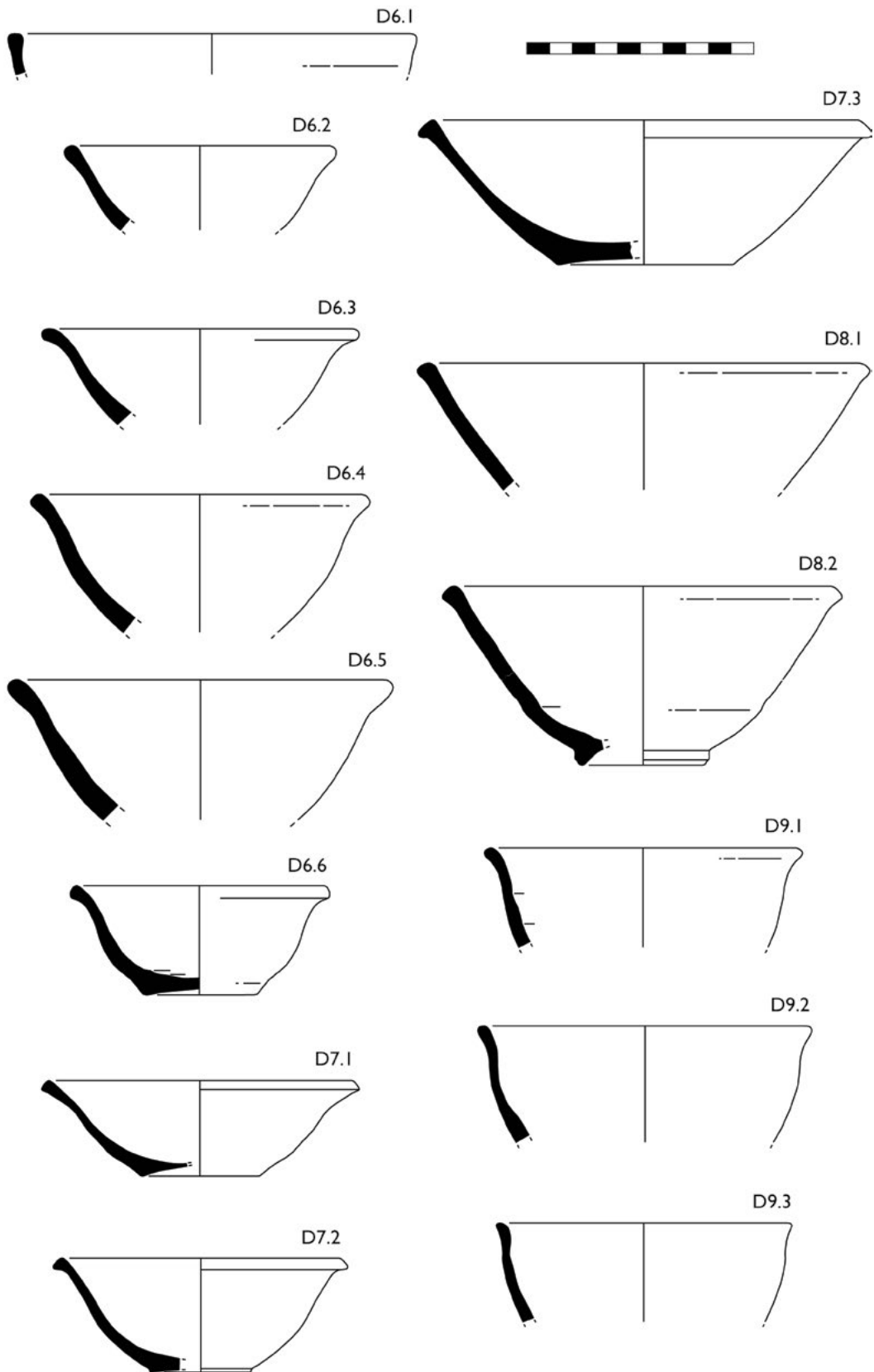

Figure 56: Local coarse ware bowl forms (D6-D9).

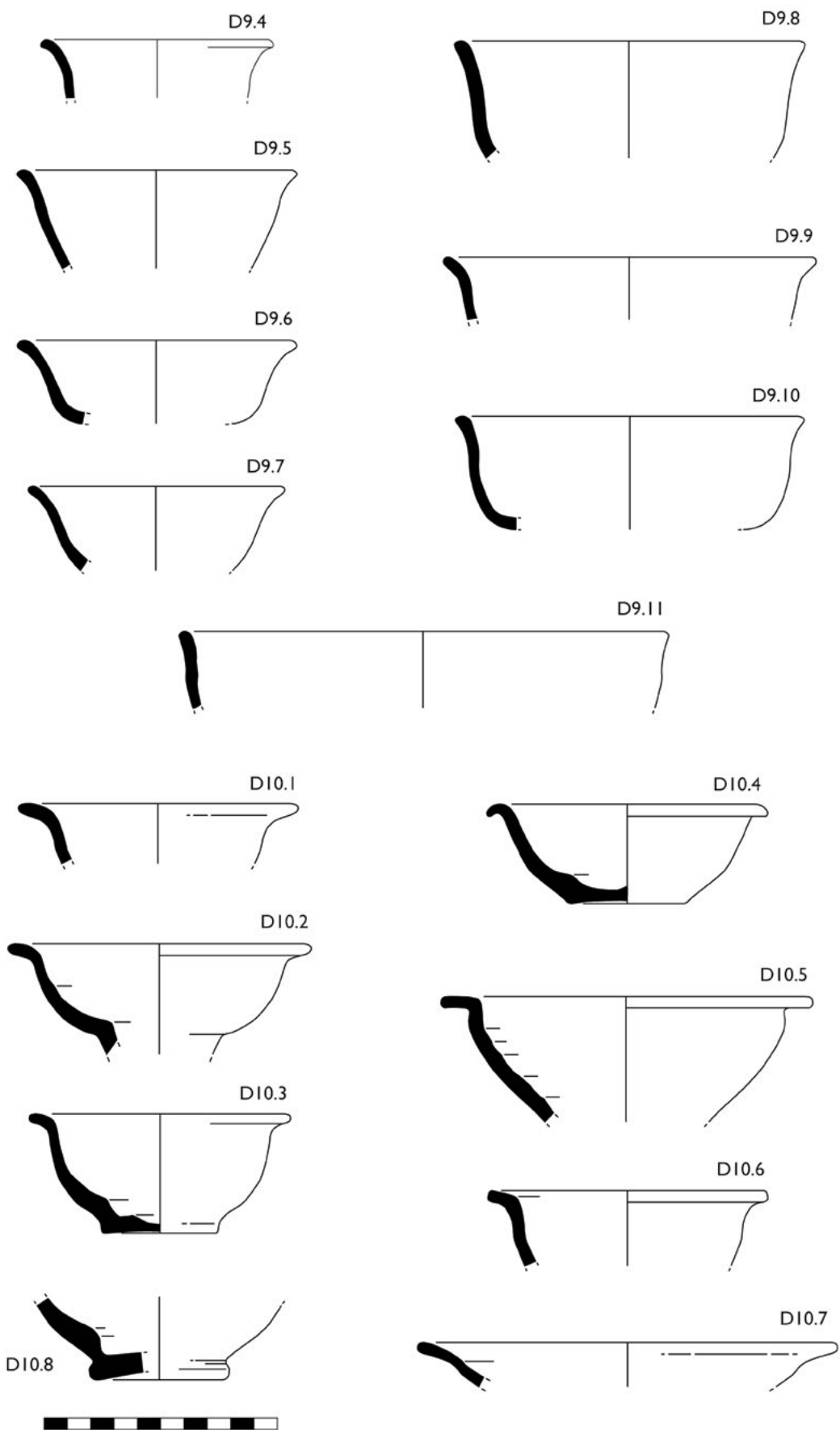

Figure 57: Local coarse ware bowl forms (D9-D10).

have been recovered from any of the deposits (Rotroff 2006: 91-92, funnel form 2).

Like practically all the other coarse ware shapes linked to the Foreman Street site, this bowl form is thought to be produced at or near the site, and has been tentatively dated to the end of the second to mid-third century.

D11.1. FRM08/57/1: Rim, d. 13. Local Fabric 2: Hard-fired red to grey fabric with large white lime and foraminifera, and some fine angular gypsum and fine black glauconite inclusions; unslipped grey surfaces. Context: Foreman Street SU 57.

D11.2. FRM08/59/2: Rim, d. 13. Local Fabric 2? Hard red fabric with fine white lime, foraminifera and occasional black glauconite inclusions; even pale grey skin; defective piece (waster) with traces of plaster. Context: Foreman Street SU 59.

D11.3. FRM08/42/41: Rim, d. 18. Local Fabric 2: Hard pale red fabric with fine white lime, foraminifera, angular translucent gypsum and occasional fine black glauconite inclusions; unslipped pale surfaces. Context: Foreman Street SU 42.

D11.4. FRM08/42/36: Rim and handle, d. 14. Local Fabric 2: Pale brown/pink fabric with fine white lime, foraminifera, some fine angular gypsum and occasional black glauconite inclusions; unslipped surfaces. Context: Foreman Street SU 42.

D11.5. FRM08/57/2: Rim, d. 14. Local Fabric 2: Hard pale red fabric with fine white lime, foraminifera, white opaque gypsum (?), and red and black glauconite inclusions; unslipped. Context: Foreman Street SU 57.

D11.6. FRM08/57/3: Rim, d. 14. Local Fabric 2: Hard pale brown compact fabric with fine white lime, foraminifera, and occasional black glauconite inclusions; unslipped pale pink skin. Context: Foreman Street SU 57.

D11.7. FRM08/42/40: Rim, d. 18. Local Fabric 2: Gritty pale red fabric with white lime, foraminifera, and black shiny glauconite inclusions; unslipped. Context: Foreman Street SU 42.

D11.8. FRM08/59/1: Rim, d. 15. Local Fabric 2: Hard red fabric with fine white lime, foraminifera, fine angular gypsum and shiny black glauconite inclusions; unslipped pale grey skin. Context: Foreman Street SU 59.

D11.9. FRM08/42/42a: Rim, d. 16. Local Fabric 2: Hard red fabric with white lime, foraminifera, and black

glauconite inclusions; unslipped pale cream skin. Context: Foreman Street SU 42; not illustrated.

## D12. Coarse ware bowl type 12 (Figure 58)

This form is morphologically very similar to type D11, but the rim is straighter after the carination and ends in a slightly bevelled, beaded rim. The rim diameters range between 12 and 23 cm. The fabric, surface treatment and dating are also the same as type D11 above. A range of minor variants has been identified, but because of the number of wasters and the nature of the site, little distinction can be drawn between these variations (for instance, D12.8-10). There is difficulty drawing local parallels for this shape as it is morphologically very similar to bowl form V: 3 and its description by Sagona, but the profile drawing available is lacking in scale and detail (Sagona 2002, fig. 348.31). Nevertheless, it is very probable that the form is also similar to a bowl from Wied il-Ghasri in Gozo, which is currently on permanent display at the National Museum of Archaeology in Victoria, Gozo (Figure 77). A North African parallel for the vessel's form may be found in Sabratha and dates to the second half of the first century AD, although this may be an isolated example (Dore 1989: 127, fig. 45.145).

D12.1. FRM08/42/3: Rim, d. 10. Local Fabric 1: Pale brown fabric with grey shell/lime, white lime and fine red ore inclusions; thick, pale white, slipped surface. This particular sherd appears to be a Punic-period antecedent of this form because of the fabric. No parallels are known. Context: Foreman Street SU 42.

D12.2. FRM08/57/8: Rim, d. 12. Local Fabric 2: Pale brown fabric with fine white lime, foraminifera, fine black glauconite and red ore inclusions; unslipped. Context: Foreman Street SU 57.

D12.3. FRM08/42/2: Rim, d. 13. Local Fabric 2 (Figure 22): Hard pale red fabric with white foraminifera, black glauconite, fine white lime and red ore inclusions; unslipped pale cream skin. Context: Foreman Street SU 42.

D12.4. FRM08/57/7: Rim, d. 15. Local Fabric 2: Hard dark grey fabric with white foraminifera, lime, black glauconite and red ore (?) inclusions; unslipped; over-fired waster. Context: Foreman Street SU 57.

D12.5. FRM08/42/1: Rim, d. 15. Local Fabric 2: Pale red fabric with fine white lime, foraminifera, and black glauconite inclusions; unslipped. Context: Foreman Street SU 42.

D12.6. FRM08/42/4: Rim, d. 18. Local Fabric 2: Hard pale brown fabric with white foraminifera, lime, black

glaucanite and few red ore inclusions; unslipped, grey surface. Context: Foreman Street SU 42.

D12.7. FRM08/57/6: Rim, d. 23. Local Fabric 2: Hard dark grey fabric with thin pale red edges with white foraminifera and black glauconite inclusions; unslipped pale pink surfaces. Context: Foreman Street SU 57.

D12.8. FRM08/42/16: Rim, d. 26. Local Fabric 2: Pale brown fabric with white lime, foraminifera, black glauconite and red ore inclusions; unslipped. Context: Foreman Street SU 42.

D12.9. FRM08/59/5: Rim, d. 18. Local Fabric 2: Pale brown fabric with white lime, foraminifera, fine black glauconite and red ore inclusions; unslipped. Context: Foreman Street SU 59.

D12.10. FRM08/59/4: Rim, d. 16. Local Fabric 2: Hard red fabric with fine white foraminifera, lime and fine black glauconite inclusions; unslipped. Context: Foreman Street SU 59.

### D13. Coarse ware plate type 13 (Figure 59)

This small, shallow plate is characterised by its short carinated, square-cut rim. A similar form was discovered in the Għar ix-Xiħ assemblage and has been dated to the third-second century BC (Quercia and Anastasi 2008-2009, fig. 7.7). This sherd is most probably residual at Foreman Street.

D13.1. FRM08/57/9: Rim, d. 16. Local Fabric 1: Red fabric with a grey core with fine lime and foraminifera inclusions; unslipped grey surfaces. Context: Foreman Street SU 57.

### D14. Coarse ware bowl type 14 (Figure 59)

This shape is the Punic precursor of the following type **D15** and is certainly a residual fragment within the Foreman Street assemblage. Many plates like this have been recorded at Għar ix-Xiħ (Quercia and Anastasi 2008-2009, fig. 7.6) and Ras il-Wardiġa (Cagiano de Azevedo *et al.* 1965, fig. 14.9), both on Gozo, and have been dated to about the third-second century BC.

D14.1. FRM08/42/17: Rim, d. 20. Local Fabric 1: Pale brown fabric with white/grey foraminifera, white lime and fine red inclusions; thick and smooth cream slipped surfaces. Context: Foreman Street SU 42; residual.

### D15. Coarse ware bowl type 15 (Figure 59)

This shape is a typical plate form that finds predecessors in the Punic period (**D14**). A shallow plate culminates

in a straight or slightly everted rim offset by a sharp carination at the shoulder. The rim diameters range between 8 and 29 cm.

The fabric and finish is like that of the previous types from Foreman Street (Local Fabric 2), and since entire profiles have been identified for this form, it is evident that these plates contain a flat to slightly concave string-cut base. A small range of variants can be identified, based on differences in wall thicknesses and the rim's projecting lip. These variants, however, are most probably unintentional, and are a result of the nature of the manufacturing process. This shape is known at Late Punic-period sites on Gozo, principally those of Għar ix-Xiħ in the Mgarr ix-Xini valley (Quercia and Anastasi 2008-2009, figs 7.7; see type **D14**) and Ras il-Wardiġa (Cagiano de Azevedo *et al.* 1965, figs 14: 2, 4 and 9). These sites have been dated to between the third and first century BC, however, the fabric of the plates found at these two sites did not contain glauconite, but instead it was made using a fine, chalky, orange lime fabric typical of the Punic period.<sup>13</sup> Both of these sites are thought to be primarily ritual in nature. Plates which share the same form and also the fabric were also recovered from the Wied il-Għasri tomb in Gozo (Sagona 2002: 1125, figs 248: 7-8, 15). Based on the context and the discovery of several wasters, the Foreman Street examples have been dated to the end of the second to mid-third century AD.

D15.1. FRM08/42/5: Profile, d. 8 (rim), d. 3.5 (base). Local Fabric 2: Hard-fired grey fabric with thin pale red edges, with white foraminifera, lime and black glauconite inclusions; unslipped pale red surfaces. Context: Foreman Street SU 42.

D15.2. FRM08/42/6: Profile, d. 9 (rim), d. 3.5 (base). Local Fabric 2: Pale brown fabric with thin pale grey core, with white foraminifera, lime, red ore and black glauconite inclusions; unslipped. Context: Foreman Street SU 42.

D15.3. FRM08/42/8: Rim, d. 13. Local Fabric 2: Hard dark grey fabric with thin red core, with fine white lime, foraminifera and black and red glauconite inclusions; unslipped grey surfaces. Context: Foreman Street SU 42.

D15.4. FRM08/59/3: Profile, d. 15 (rim), d. 6 (base). Local Fabric 2: Pale red fabric with thick pale grey core, with white foraminifera, lime, red ore and black glauconite inclusions; unslipped. Context: Foreman Street SU 59.

<sup>13</sup> This fabric is a variant of Local Fabric 1 and was used for forms similar to **D13** and **D14** at the Għar ix-Xiħ site.

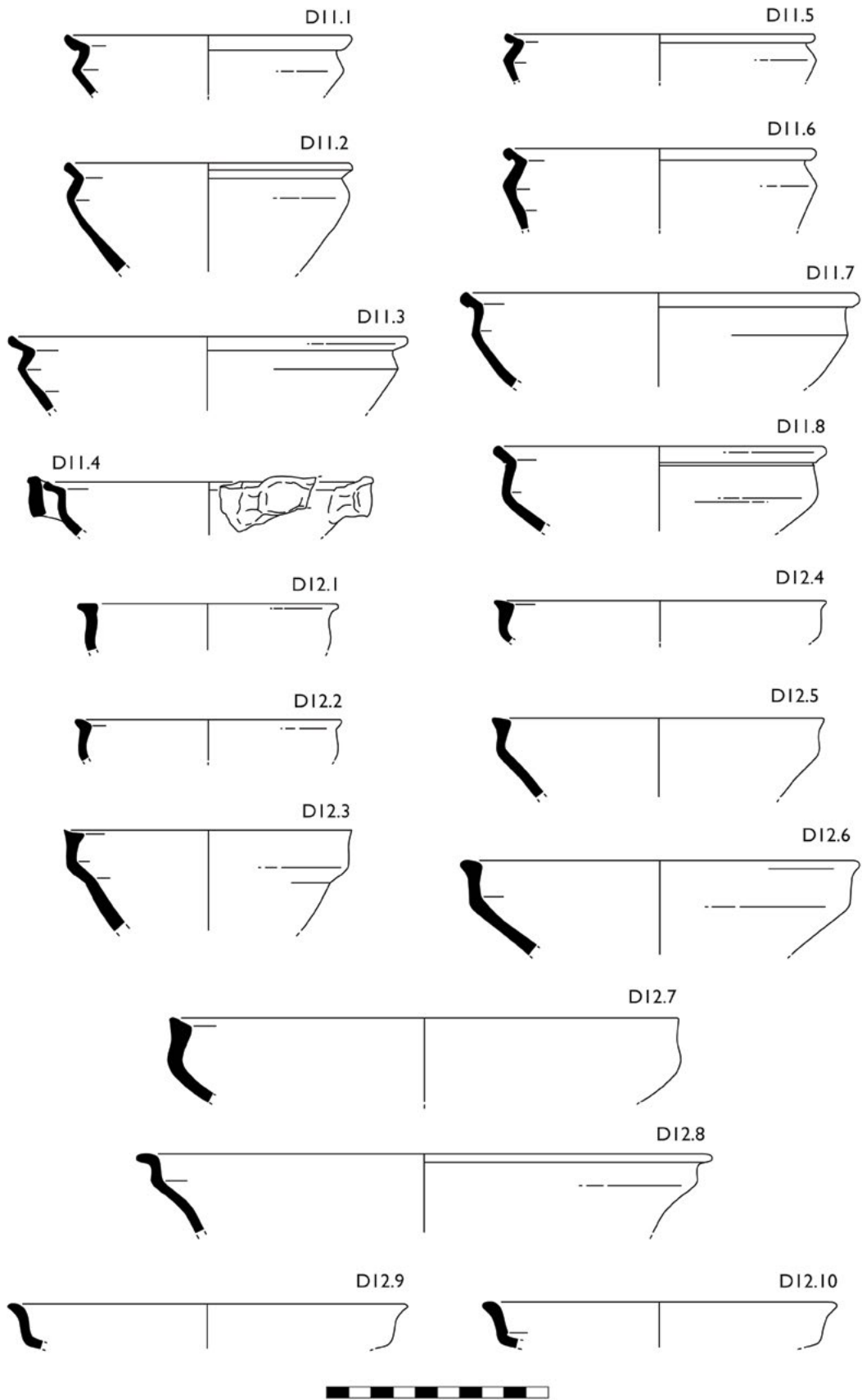

Figure 58: Local coarse ware bowl forms (D11-D12).

- D15.5. FRM08/57/12: Rim, d. 14. Local Fabric 2: Pale brown fabric with fine white lime, foraminifera, black and red glauconite inclusions; unslipped pale surfaces. Context: Foreman Street SU 57.
- D15.6. FRM08/42/12: Rim, d. 17. Local Fabric 2: Red fabric with fine white foraminifera, lime, fine black glauconite and occasional angular gypsum inclusions; unslipped pale surfaces. Context: Foreman Street SU 42.
- D15.7. FRM08/57/10: Rim, d. 18. Local Fabric 2: Hard dark grey fabric with burnt lime, fine white foraminifera, and black glauconite inclusions; unslipped pale grey skin; over-fired? Context: Foreman Street SU 57.
- D15.8. FRM08/42/10: Rim, d. 19. Local Fabric 2: Hard pale red fabric with lots of fine yellow lime and fine white foraminifera, occasional large red ore and black glauconite inclusions; unslipped grey surfaces; mis-fired waster. Context: Foreman Street SU 42.
- D15.9. FRM08/42/13: Rim, d. 22. Local Fabric 2: Orange-red fabric with fine white lime, angular gypsum, foraminifera and black glauconite inclusions; unslipped. Context: Foreman Street SU 42.
- D15.10. FRM08/42/14: Rim, d. 22. Local Fabric 2: Pale brown to grey fabric with fine foraminifera, red and black glauconite inclusions; unslipped pale brown skin. Context: Foreman Street SU 42.
- D15.11. FRM08/57/11: Rim, d. 24. Local Fabric 2: Red fabric with white lime, foraminifera, angular translucent gypsum, red ore and black glauconite inclusions; unslipped cream skin. Context: Foreman Street SU 57.
- D15.12. FRM08/42/15: Rim, d. 22. Local Fabric 2: Hard red fabric with lots of fine white lime and foraminifera, occasional black glauconite and red ore inclusions; unslipped cream-grey skin. Context: Foreman Street SU 42.
- D15.13. FRM08/42/11: Rim, d. 22. Local Fabric 2: Hard dark grey fabric with fine white lime and foraminifera, and black glauconite inclusions; unslipped; mis-fired waster. Context: Foreman Street SU 42.
- D15.14. FRM08/42/9: Rim, d. 14. Local Fabric 2: Pale red fabric with fine white lime, foraminifera, red ore and black glauconite inclusions; unslipped; misshapen waster. Context: Foreman Street SU 42.

#### D16. Coarse ware bowl type 16 (Figure 60)

Two bowl rim sherds from Bulebel and Foreman Street exhibit a thickened, bevelled rim with a slightly

carinated wall. Both Local Fabrics 1 and 2 have been employed for the manufacture of this vessel, but it is unclear whether there is any production link between the two pieces. No clear local parallels are known and too few fragments have been recovered to support any further conclusions. The finds' contexts suggest that this form was in use at least between the first century BC and mid-third century AD.

D16.1. BLB12/58/13: Rim, d. 20. Local Fabric 1: Pale orange fabric with white lime and foraminifera inclusions; unslipped. Context: Bulebel SU 58, Phase 1.

D16.2. FRM08/59/40: Rim, d. 20. Local Fabric 2: Dark grey to black fabric with glauconite and white lime inclusions; unslipped black surface; over-fired? Context: Foreman Street SU 59.

#### D17. Coarse ware bowl type 17 (Figure 60)

This bowl is similar in shape to the local red-slipped version, type **B15**. The form is characterised by a simple inward-curving rim with a shallow groove (**D17.1-2**) or pronounced ridge (**D17.3**) just beneath the rim. This form was only found at Melita and based on the context has been dated to around the mid-third to mid-fourth century like the red-slipped version. Both Local fabrics 1 and 2 have been used in the manufacture of this form, although Local Fabric 1 predominates. No parallels are known locally.

D17.1. MLT84/49380.1: Rim, d. 18. Local Fabric 1: Pale orange fabric with fine white lime inclusions; thin, pale red skin; red-slipped? Context: Melita SUs 1093 and 1084, Phase 4.

D17.2. MLT84/49380.2: Rim, d. 22. Local Fabric 1: Pale orange fabric with white lime and foraminifera inclusions; unslipped pale red skin. Context: Melita SU 1093, Phase 4.

D17.3. MLT84/49501: Rim, d. 28. Local Fabric 2: Hard pale grey fabric with fine lime and black glauconite inclusions; pale brown exterior surfaces. Context: Melita SU 1088, Phase 4.

#### D18. Coarse ware bowl type 18 (Sagona bowl form VI: 4a) (Figure 60)

This is a shallow bowl, possibly a development of Sagona bowl form IV-V: 3b/V: 4, which has a carinated shoulder, flat base and an everted rim that contains a top groove. These bowls are known from tomb contexts recorded by Sagona and can be red-slipped (type **B9**) or unslipped (Sagona 2000: 188). Similar shapes have been recorded by Riley in the Berenice assemblage in Cyrenaica (Riley 1979: 523, D470). These forms were recovered from the Bulebel tombs and are associated with ARS forms Hayes

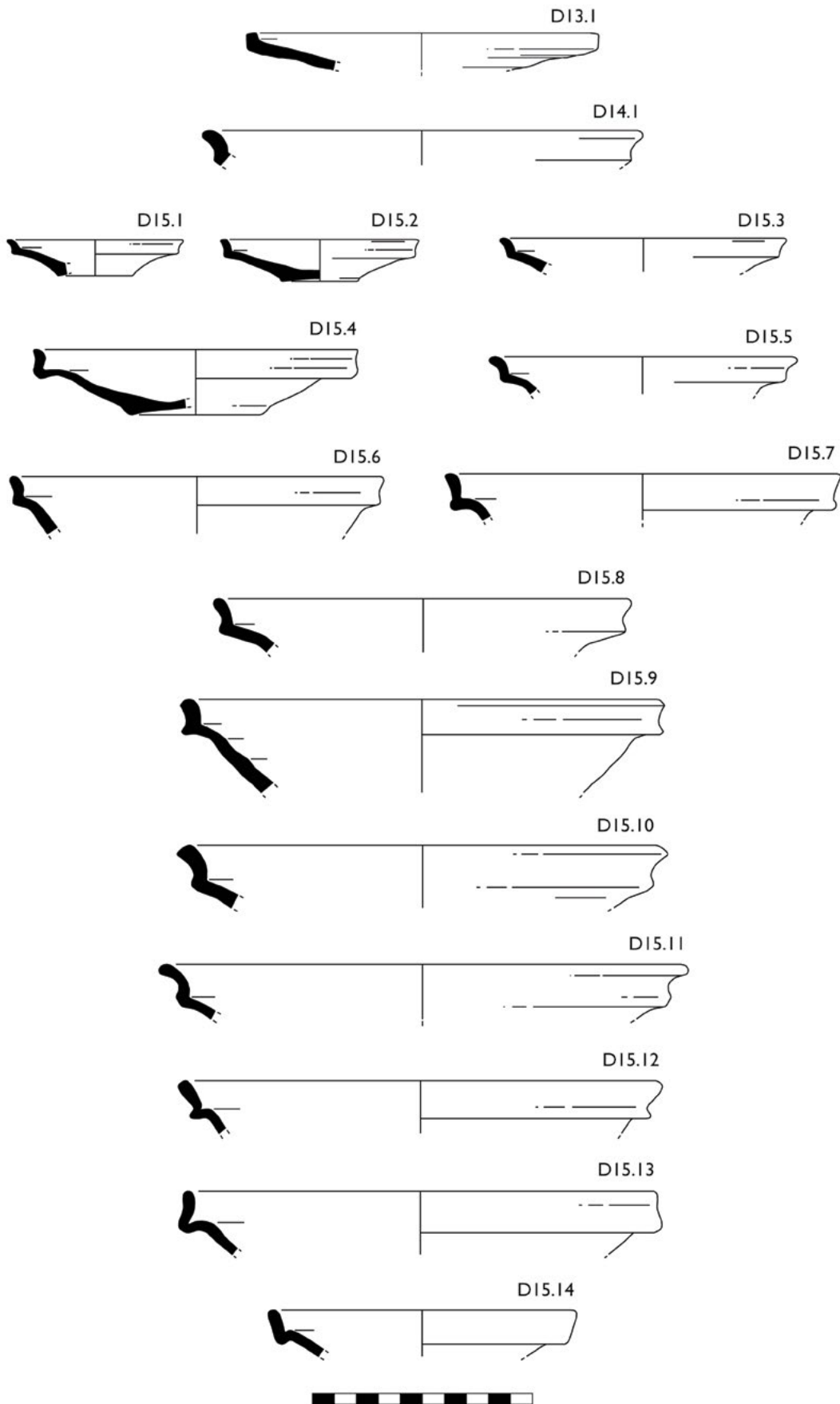

Figure 59: Local coarse ware bowl forms (D13-D15).

31 (B40.4) and Hayes 50A (B40.11), and can thus be dated to about the mid-third century.

D18.1. BLB12/11/6: Complete vessel, d. 13 (rim), d. 5 (base). Local Fabric 2: Pale red fabric with large yellow and white lime, grog and fine black glauconite inclusions; string-cut flat base; pale brown unslipped surface. Context: Bulebel SU 11, tomb 3.

D18.2. BLB12/71/3: Complete vessel, d. 13 (rim), d. 5 (base). Local Fabric 1: Pale brown fabric with fine lime and foraminifera inclusions; string-cut flat base; rough, wet-wiped unslipped pale surface. Context: Bulebel SU 71, tomb 3.

D18.3. BLB12/70/2: Complete vessel, d. 14 (rim), d. 5 (base). Local Fabric 1: Pale red to pink fabric with fine white lime and foraminifera inclusions; string-cut flat base; unslipped cream surfaces. Context: Bulebel SU 70, tomb 3.

#### D19. Coarse ware bowl type 19 (Figure 60)

Only one example of this form has been identified within the three assemblages. The small bowl has a collared, sloping rim. The base is small, flat and string cut with two added small discs of clay arranged in a tripod manner. A third 'foot' is missing, with an indent in place of it instead. The form resembles Sagona's bowl form VI: 5c, dated to after the mid-first century AD, but the forms do not share the same dimensions (Sagona 2002: 190, fig. 349.47). This sherd is from a context that contains material dating to the mid-third-mid-fourth century.

D19.1. MLT84/26190: Profile, d. 11 (rim), d. 5 (base). Local Fabric 2: Pale orange fabric with white lime, foraminifera and black glauconite inclusions; unslipped; string-cut flat base with two added clay discs. Context: Melita SU 1099, Phase 5.

#### D20. Coarse ware bowl type 20 (Figure 60)

Only one example of this form was recovered. The small bowl is characterised by a simple rim and a flat, string-cut base. A suggested date is sometime after the mid-first century, but the fabric (Local Fabric 3) might indicate that the vessel is later.

D20.1. BLB12/32/34: Profile, d. 9 (rim), d. 4 (base). Local Fabric 3: Hard pale red fabric with white lime, gypsum, black glauconite and mixed inclusions; unslipped pale surfaces; string-cut flat base. Context: Bulebel SU 32, Phase 2.

#### D21. Coarse ware bowl type 21 (Figure 60)

Like the previous two forms, only a single example of this flanged bowl form was identified. Flanged bowls

are rare on Malta, and no local parallels have been traced to date. The vessel is from a context that dates to the mid-third-mid-fourth century.

D21.1. MLT84/25210: Rim, d. 17. Local Fabric 1: Fine red fabric with fine white lime inclusions; unslipped. Context: Melita SU 1071, Phase 5.

#### D22. Coarse ware bowl type 22 (Figure 61)

This general group of deep cups/bowls is attributed to the Foreman Street 'workshop'. The main shape is characterised by a Z-shaped profile with a simple and everted rim. No complete profiles are known and no bases have been associated with the form. The shape is not very common but the basic profile is similar to the general class of bowl shapes made within the vicinity of the site. The production is dated to the end of the second-mid-third century.

D22.1. FRM08/42/30: Rim, d. 10. Local Fabric 2: Hard red fabric with fine white foraminifera, lime and shiny black glauconite inclusions; unslipped pale pink/cream skin. Context: Foreman Street SU 42.

D22.2. FRM08/42/43: Rim, d. 14. Local Fabric 2: Brown fabric with thin grey core, with fine white foraminifera, lime and black glauconite inclusions; unslipped pale skin. Context: Foreman Street SU 42.

D22.3. FRM08/59/7: Rim, d. 13. Local Fabric 2: Pale brown fabric with fine white lime, foraminifera, and black glauconite inclusions; unslipped pale grey skin. Context: Foreman Street SU 42.

D22.4. FRM08/42/25: Rim, d. 13. Local Fabric 2: Pale red fabric with fine white lime, foraminifera and black glauconite inclusions; unslipped. Context: Foreman Street SU 42.

#### D23. Coarse ware plate type 23 (Figure 61)

This individual plate form has a narrow, flattened rim similar to Punic-period examples, such as those from the sanctuary at Tas-Silg, and which are broadly dated to the about the fifth-third century BC based on the similarity with Quercia's plate type 5 (Quercia 2004-2005, fig. 5.5). Only a single example was recovered and it is probably residual.

D23.1. MLT84/24826: Rim, d. 24. Local Fabric 1: Pale orange fabric with yellow and white lime and foraminifera inclusions; unslipped pale surfaces. Context: Melita SU 1066, Phase 4; residual.



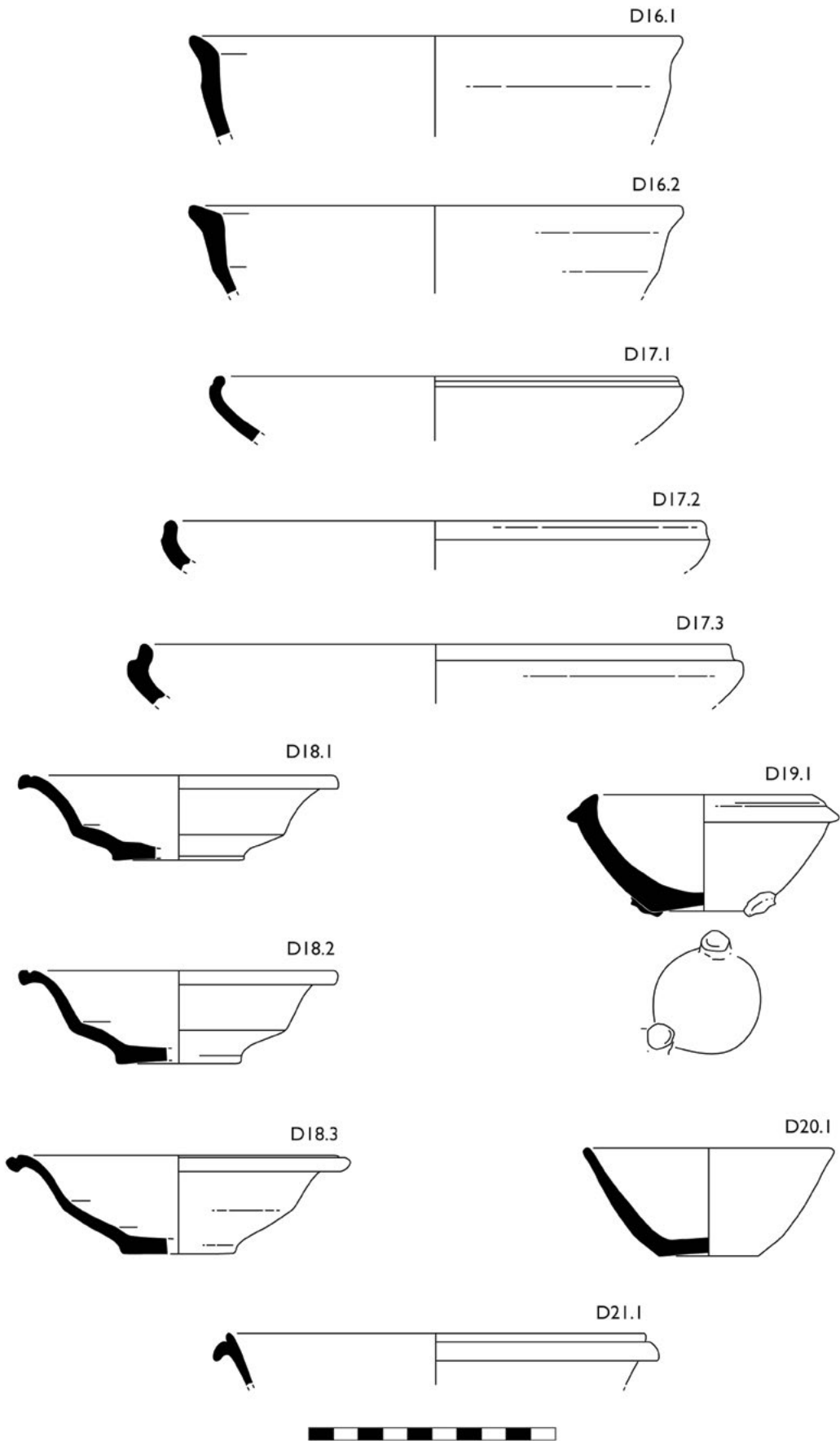

Figure 60: Local coarse ware bowl forms (D16-D21).

**D24. Coarse ware plate type 24 (Figure 61)**

This plate rim is a local imitation of an imported Hellenistic black-slipped form, similar in shape to the Morel 1315 series (Morel 1994, pl. 13). Local imitations of Hellenistic forms are very common for Maltese coarse ware vessels, but this particular form is not well-known on the island.

D24.1. MLT84/49704: Rim, d. 24. Local Fabric 1: Hard pale red fabric with a thick grey core, with lots of white lime and grog inclusions; unslipped, rough, pale grey/cream salt-slipped skin. Context: Melita SU 1104, Phase 2.

**D25. Coarse ware plate type 25 (Figure 61)**

Like the previous form, this plate is also a local imitation of a Hellenistic fine ware, following a series of black-slipped vessels like the 'debased' Lamboglia 6 from Berenice (Kenrick 1985, fig. 7.55) and Morel's series 1441-1443 (Morel 1994, pls 17-18). Three examples including a complete profile with a tidy disc base were recorded at Bulebel. Two of these have a fabric that contains a little glauconite (Local Fabric 2), whilst the third does not (Local Fabric 1). All these, however, are well-finished, with a dry-shaved, smoothed cream-slipped surface. Kenrick suggests a date for the black-slipped plate at the end of the second century BC (Kenrick 1985: 45), whilst the local examples can be dated to no later than the mid-end of the first century AD from their context association. No other local parallels are known.

D25.1. BLB12/55/16: Rim, d. 24. Local Fabric 2: Pale orange fabric with yellow lime and white foraminifera inclusions, with a few black glauconite inclusions; dry-shaved, cream-slipped surfaces. Context: Bulebel SU 55, Phase 1.

D25.2. BLB12/54/5a: Rim, d. 22. Local Fabric 1? Pale brown fabric with white lime, foraminifera, red ore and sand-like, dark glauconite (?) inclusions; dry-shaved cream/pink mottled and smoothed surfaces. Context: Bulebel SU 54, Phase 1.

D25.3. BLB12/57/4: Profile, d. 24 (rim), d. 6.8 (base). Local Fabric 2: Hard pale brown fabric with fine white lime, foraminifera, red ore/grog inclusions, and traces of a little glauconite grains; matt, dry-shaved grey exterior surfaces. Context: Bulebel SU 57, Phase 1.

**D26. Coarse ware plate type 26 (Quercia plate types 4-5) (Figures 61 and 62)**

This plate group includes a series of Late Punic forms common on the islands – Malta in particular – and can be attributed to a series of Late Punic/Early Roman

plates produced in large numbers at Tas-Silġ from contexts dating to as early as the fourth century BC, but continue until at least the first half of the first century BC (Quercia 2011: 437, fig. 1.4-5). They have been grouped together here because of their relative infrequency (probably due to their waning popularity in the early Imperial period), and the distinct wide-brimmed rim each example displays. Examples with a rolled rim (i.e. **D26.3**) are also known at Tas-Silġ and are roughly contemporary with the other two plate forms (Sagona 2015, fig. 1.94:5-6). The presence of glauconite inclusions in two of the Bulebel examples (**D26.1** and **D26.3**) and their presence in a mid-first-century context (and later) may suggest that the date for this plate type could be extended by a century.

D26.1. BLB12/58/10: Rim, d. 24. Local Fabric 2: Pale red fabric with fine white lime, foraminifera and black glauconite inclusions; under-fired green surface? Context: Bulebel SU 58, Phase 1.

D26.2. BLB12/58/29: Profile, d. 19 (rim), d. 7 (base). Local Fabric 1: Pale orange fabric with yellow lime and red ore/grog inclusions; string-cut base; wet-wiped pale yellow skin. Context: Bulebel SU 58, Phase 1.

D26.3. BLB12/44/2: Rim, d. 20. Local Fabric 2: Pale red fabric with white lime, foraminifera and black glauconite inclusions; unslipped cream skin. Context: Bulebel SU 44, Phase 2.

**D27. Coarse ware plate type 27 (Quercia plate types 6-8) (Figure 62)**

The morphology of this type developed from the previous range of plates (type **D26**). The plate is characterised by a wide flaring triangular rim, thin walls, and the disappearance of a distinct rim ledge, typical of the earlier versions. The rim ends in a triangular bead, and the bases remain flat and are often string-cut. This general class of plates is also very common on Maltese sites, in particular Tas-Silġ and the Żejtun villa (Anastasi 2012, fig. 3.16, 26), and has also been recorded in some tomb contexts (Sagona 2002: 212, fig. 346.39). Quercia has classified this type and dated it from the first century BC until at least the mid-first century AD (Quercia 2011: 438, fig. 1.6-8). This plate series has significantly more forms using Local Fabric 3 than the earlier types.

D27.1. BLB12/24/6: Rim, d. 18. Local Fabric 2: Pale orange/brown fabric with fine white lime, foraminifera and fine black glauconite inclusions; unslipped pale skin. Context: Bulebel SU 24, Phase 2.

D27.2. BLB12/32/33: Profile, d. 22 (rim), d. 6.5 (base). Local Fabric 3: Hard pale red fabric with a grey core, with black glass-like inclusions, gypsum and white

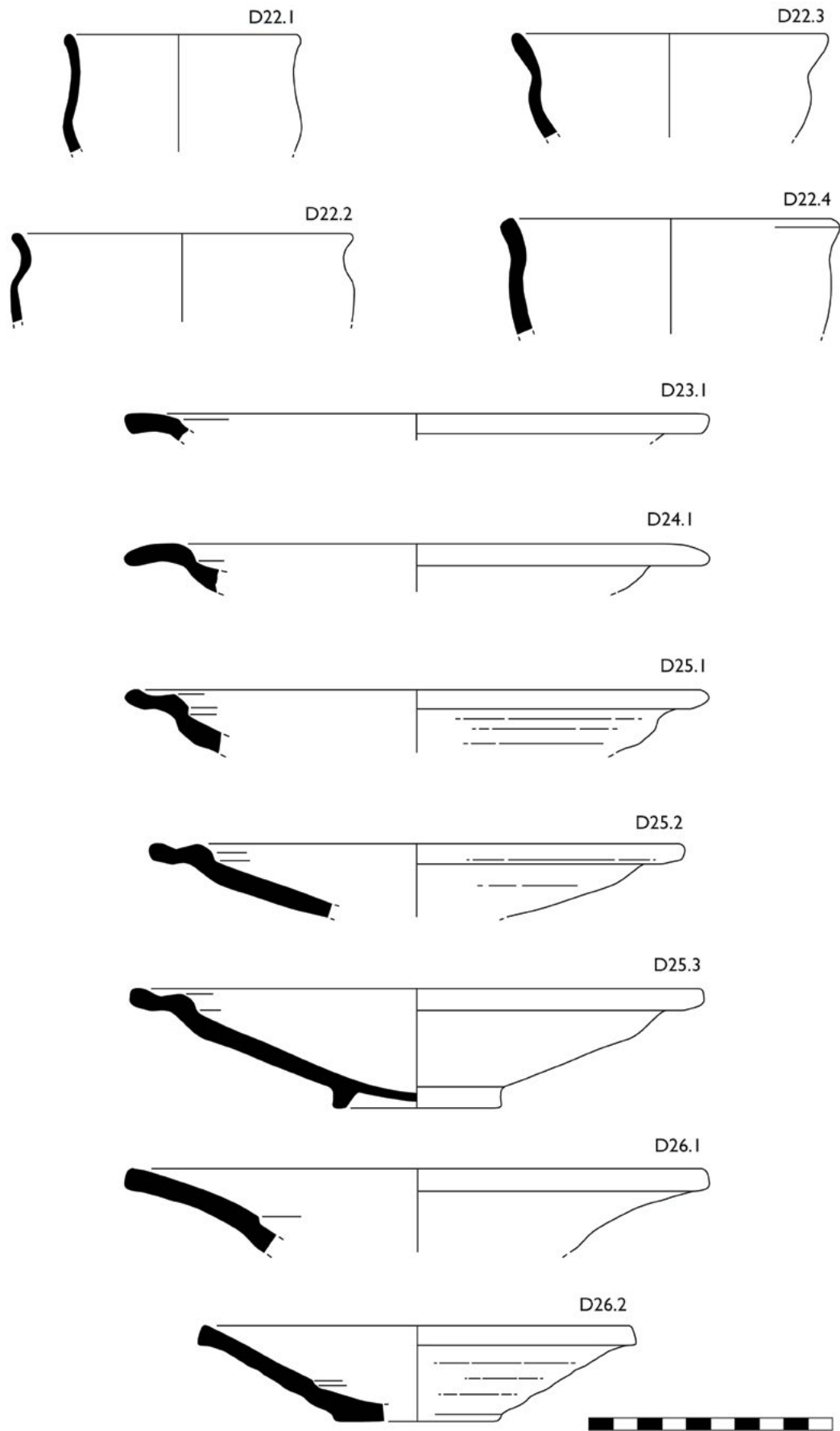

Figure 61: Local coarse ware bowl (D22) and plate (D23-D26) forms.

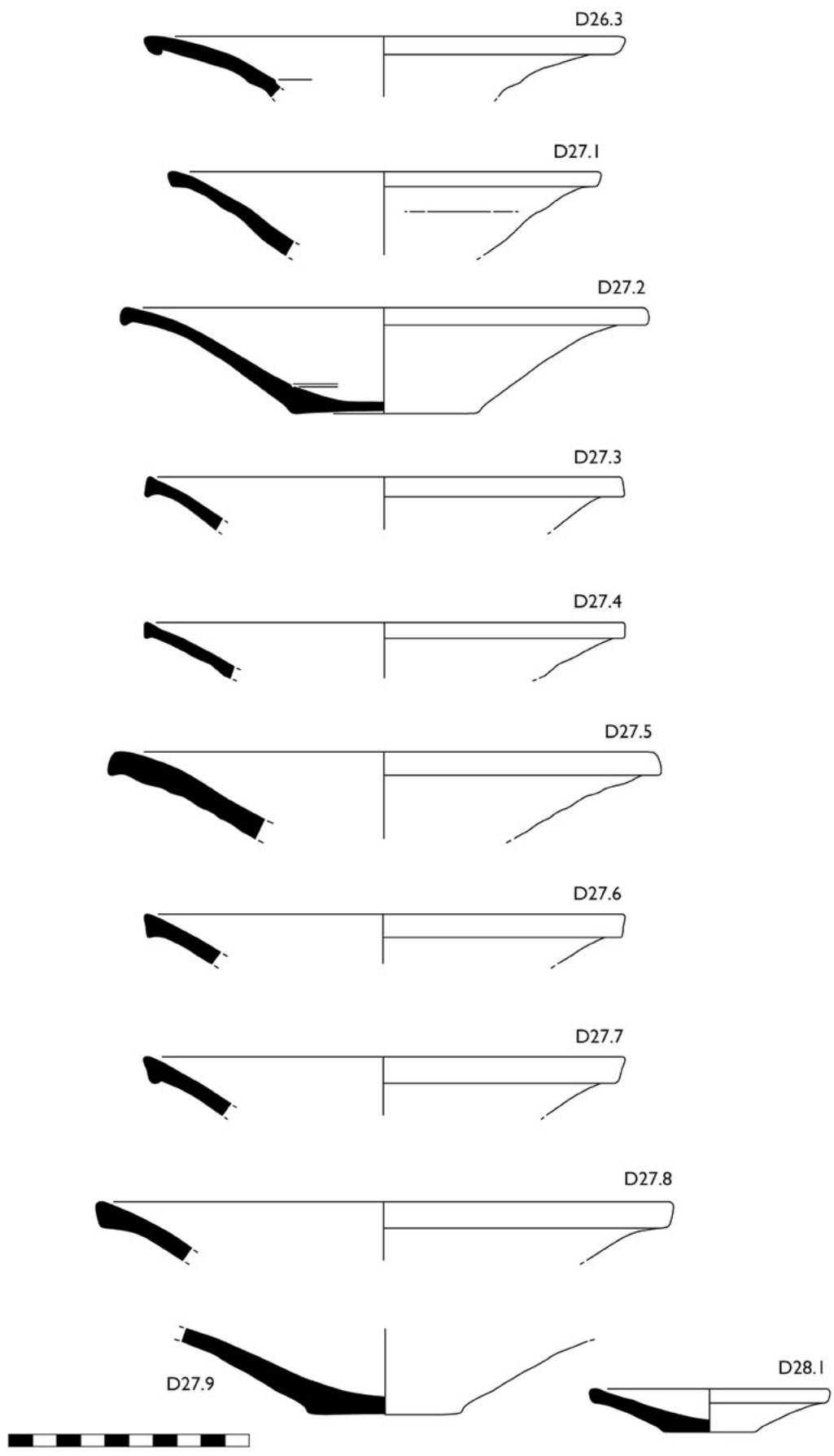

Figure 62: Local coarse ware plate forms (D26-D28).

lime inclusions; flat string-cut base; unslipped pale skin. Context: Bulebel SU 32, Phase 2.

D27.3. BLB12/32/14: Rim, d. 20. Local Fabric 3 (**Figure 23**): Orange fabric with red ore, dark glass-like temper and gypsum inclusions; unslipped pale surface. Context: Bulebel SU 32, Phase 2.

D27.4. BLB12/24/4: Rim, d. 20. Local Fabric 3: Orange fabric with black glass temper, red ore, white lime and angular gypsum inclusions; cream-coloured surface. Context: Bulebel SU 24, Phase 2.

D27.5. BLB12/58/11: Rim, d. 23. Local Fabric 1 (**Figure 22**): Soft, pale brown fabric with large red grog and white lime inclusions; unslipped cream-coloured skin. Context: Bulebel SU 58, Phase 1. This particular example could also be a lid (?).

D27.6. BLB12/32/16: Rim, d. 20. Local Fabric 2: Orange fabric with white lime, foraminifera and irregular, but large, glauconite inclusions; unslipped. Context: Bulebel SU 32, Phase 2.

D27.7. BLB12/41/1: Rim, d. 20. Local Fabric 3? Hard pale orange fabric with fine white and grey lime and foraminifera, and fine angular gypsum inclusions; unslipped. Context: Bulebel SU 41, Phase 2.

D27.8. BLB12/55/15: Rim, d. 24. Local Fabric 1: Red fabric with white lime and darker grog inclusions; under-fired pale colour. Context: Bulebel SU 55, Phase 1.

D27.9. BLB12/32/13: Base, d. 6.5. Local Fabric 3: Orange fabric with white lime, foraminifera, black glass and gypsum inclusions; flat string-cut; unslipped. Context: Bulebel SU 32, Phase 2.

### D28. Coarse ware plate type 28 (**Figure 62**)

Only three examples of this small plate have been identified and are probably residual Late Punic pieces. The form is one of the more common coarse ware forms within the ritual deposits at Tas-Silġ and has a wide chronology, ranging from the second half of the second century BC to the mid-late first century AD (Quercia 2011: 444, fig. 3.2; Sagona 2002: 213, fig. 347.15-16; 2015, fig. 1.98:5-14).

D28.1. MLT84/26144: Profile, d. 10 (rim), d. 3.5 (base). Local Fabric 1: Orange fabric with fine yellow and white lime and foraminifera inclusions; unslipped; flat, string-cut base. Context: Melita SU 1096, Phase 5; residual?

### D29. Coarse ware bowl type 29 (**Figure 63**)

This shallow bowl has low, sloping, and slightly ribbed, walls ending in a triangular hooked rim. The base is flat and string-cut. Local parallels have not been found, although their general absence from Late Punic/early Roman contexts like Tas-Silġ and Żejtun suggests that this form may belong to a local form produced after the end of the first century AD, as it is only found in contexts that date to between the end of the first and the early-mid-third century AD (Bulebel, Phase 2). The fact that nearly all the examples recorded are made using Local Fabric 3 further supports this later Imperial date.

D29.1. BLB12/23/2: Profile, d. 18 (rim), d. 6.5 (base). Local Fabric 3: Hard-fired orange fabric with fine white/yellow lime and foraminifera, and angular gypsum inclusions; unslipped pale surfaces; flat string-cut base. Context: Bulebel SU 23, Phase 2.

D29.2. BLB12/39/10: Rim, d. 18. Local Fabric 3: Pale orange fabric with black glass, gypsum, red ore and white lime inclusions; unslipped, slightly ribbed exterior surface. Context: Bulebel SU 39, Phase 2.

D29.3. BLB12/39/13: Profile, d. 18 (rim), d. 6 (base). Local Fabric 3: Orange fabric with black glass, gypsum, red ore and white lime and foraminifera inclusions; unslipped; string-cut base. Context: Bulebel SU 39, Phase 2.

D29.4. BLB12/39/11: Rim, d. 19. Local Fabric 1: Pale orange fabric with white lime and foraminifera inclusions; unslipped pale surface. Context: Bulebel SU 39, Phase 2.

### D30. Coarse ware bowl type 30 (**Figure 63**)

Only a single example of this form was recorded. The deep plate or bowl is characterised by wide flaring walls ending in a triangular rim, and double incised grooves score the top interior wall. No local parallels are known, and a combination of the fabric (Local Fabric 2) and the context suggest a date in the mid-third-fourth century.

D30.1. MLT84/24855: Rim, d. 29. Local Fabric 2: Grey fabric with white lime, foraminifera and black glauconite inclusions; unslipped. Context: Melita SU 1067, Phase 4.

### D31. Coarse ware bowl type 31 (**Figure 63**)

This open shape could belong to a lid or a plate. The triangular rim is attached to a thin and flaring wall. Like the previous type, only one example was identified but can be attributed to the Foreman Street production site, datable to the end of the second to the mid-third century AD.

D31.1. FRM08/42/55: Rim, d. 25. Local Fabric 2: Hard orange fabric with fine white lime, foraminifera and fine black glauconite inclusions; unslipped. Context: Foreman Street SU 42.

*Painted coarse wares (D32-D35)*

**D32. Painted bowl type 1 (Figure 64)**

This large plate has a sloping floor, with a stepped, rolled rim. The interior surface and the top of the exterior rim are coated with a thin, matt red slip or paint. The fabric is similar to Local Fabric 1, however a possible foreign source cannot be excluded. Only one example of this large plate was found and can be compared to Campanian B and Eastern sigillata A plates recorded at Berenice (Kenrick 1985: 35, 227, figs 5.18, 41.316.1-2). These imported fine ware examples can be dated from the second half of the second to the last quarter of the first century BC. No local parallels are known. The foreign shapes could provide a *terminus post quem* for the introduction of this form.

Their absence in any Late Punic assemblages and the discovery of this form in a mid-late first century AD context suggests a general date sometime between that. The red interior colour may also be inspired by Pompeian Red ware dishes that were being circulated around the central Mediterranean at this time.

D32.1. BLB12/55/10: Rim, d. 34. Local Fabric 1? Hard-fired dark orange fabric with fine white lime inclusions; thin red-painted interior and part of exterior; local production? Context: Bulebel SU 55 and 58, Phase 1.

**D33. Painted bowl type 2 (Figure 64)**

This thickened rim with a ridge also contains a thick red slip on the interior surface. The fabric contains black volcanic inclusions and could thus be a Campanian import, although a local source cannot be excluded because of the presence of volcanic material in locally produced amphorae and some coarse wares (see Local Fabric 6). No local parallels are known and not enough of the vessel was found to find foreign parallels. The context dates the vessel to sometime before the early third century.

D33.1. BLB12/30/4: Rim, d. 40. Local Fabric 6? Hard red fabric with black volcanic sand and fine white lime (?) inclusions; red-slipped interior and top of exterior rim. Context: Bulebel SU 30, Phase 2.

**D34. Painted bowl type 3 (Figure 64)**

This form resembles a series of Hellenistic *lekane* or large bowls with wide flaring rims and small horizontal

ornamental loop handles (**D34.1**). A series of shallow grooves is incised on the top interior wall. Thin red painted lines radiate along the interior rim. A few fragments of similar bowls come from San Pawl Milqi in contexts dated from the third-second century BC to the second half of the first century AD (Bozzi *et al.* 1968: 63, 66, figs 7.25, 40, 34.1-2). The present examples were made using Local Fabric 1 and 3, the latter fabric further supporting a later date. Most of the examples of this form were recovered from contexts that date between the end of the first and early third century (Bulebel Phase 2).

The closest foreign parallel can be identified with the Hellenistic *lekane* form 1 from the Athenian agora dated to between the beginning of the third and early first century BC (Rotroff 2006: 109, figs. 39-41, nos 234-248). The form does not appear to be common at Berenice, although three rims in a miscellaneous Hellenistic category could belong to similar vessels (Riley 1979: 290, nos D640-641). ARS versions of a similar form, however with a frilled or finger-impressed rim (this detail is not found on any of the Maltese examples), are known from Carthage dated to the first-early second century AD (Hayes 1976: 72-73; Fulford and Timby 1994: 17, fig. 1.7, no. 2). coarse wares versions are also common from the first-the early second century AD contexts at Utica.

D34.1. BLB12/28/16: Rim and handle, d. 44. Local Fabric 3: Pale brown fabric with glauconite, red ore and fine angular gypsum inclusions; unslipped, smoothed pale surface with red-painted radial lines on the top interior of the rim (**Figure 44**); decorative horizontal loop handle beneath rim. Context: Bulebel SU 28, Phase 2.

D34.2. BLB12/30/3: Rim, d. 34. Local Fabric 2-3: Orange fabric with white lime, gypsum and fine glauconite inclusions; unslipped, smooth surfaces; thin red-painted lines on top of interior surface of rim. Context: Bulebel SU 30, Phase 2.

D34.3. BLB12/14/4: Rim, d. 42. Local Fabric 3: Pale brown fabric with green grog, white lime, red ore, fine black glauconite and gypsum inclusions; unslipped pale surface with red-painted lines on the interior top of rim. Context: Bulebel SU 14, Quarry 2.

D34.4. BLB12/42/5: Rim, d. 40. Local Fabric 3 or 6? Gritty pale red fabric with white lime and black/green volcanic (?) glass inclusions; unslipped. Context: Bulebel SU 42, Phase 2.

D34.5. BLB12/14/5: Shoulder, d. c. 45-50. Local Fabric 3: Pale red fabric with gypsum, white lime and fine black inclusions; shoulder sherd, grooved on underside of exterior; unslipped; thin red-painted line on interior rim surface. Context: Bulebel SU 14, Quarry 2.

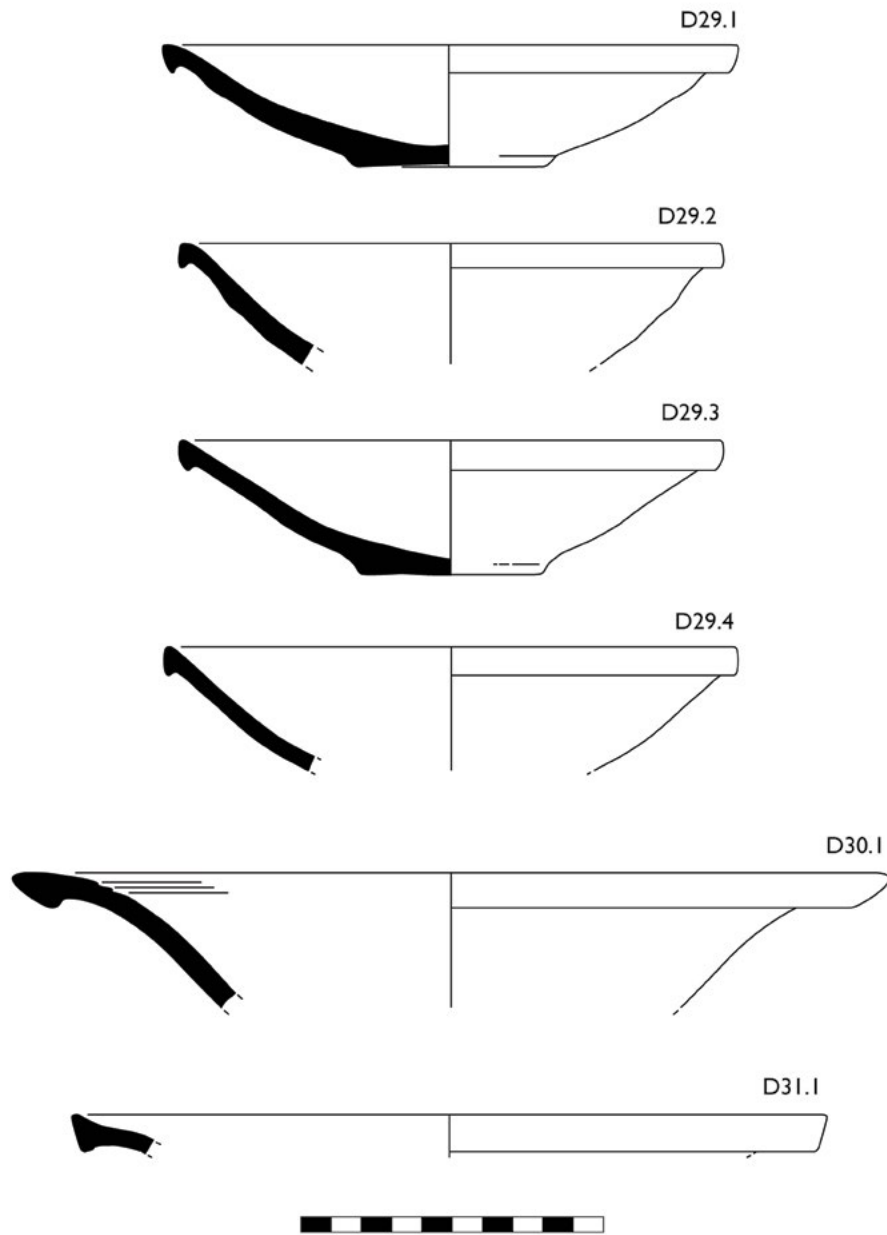

Figure 63: Local coarse ware bowl forms (D29-D31).

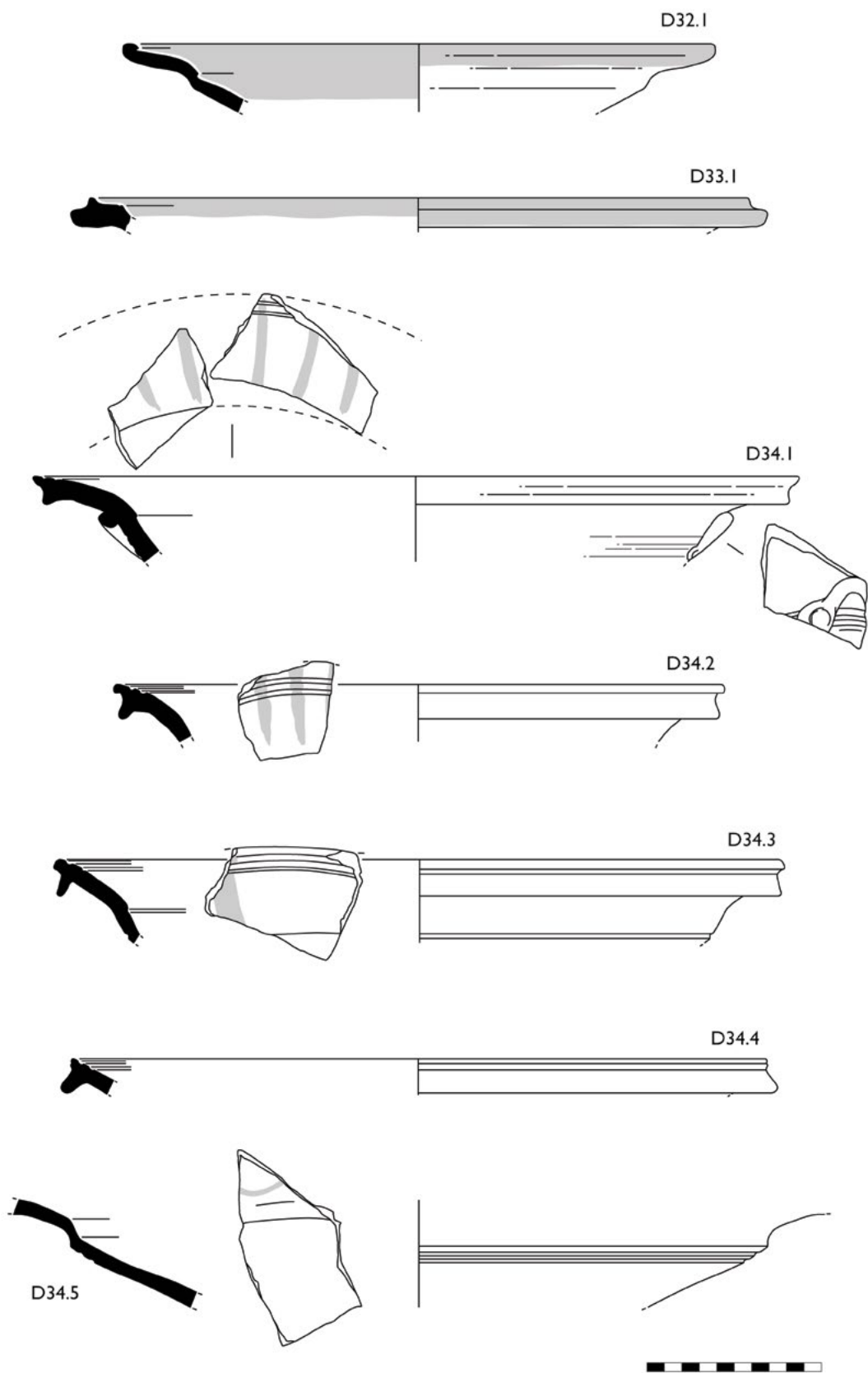

Figure 64: Painted coarse ware bowl forms (D32-D34)



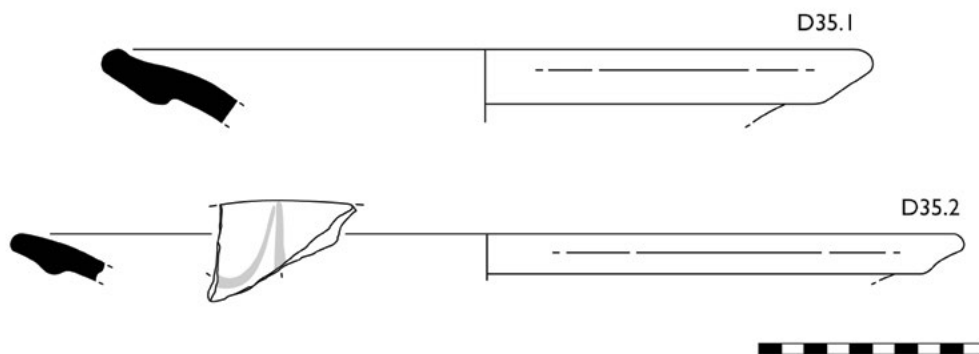

Figure 65: Painted coarse ware plate form D35.

### D35. Painted plate type 4 (Figure 65)

This form, characterised by a thick and flaring collared plate rim, is only represented by two examples, and no other local parallels are known. The fabric is similar to Local Fabric 1. One example (D35.2) contained thin red-painted U-shaped bands along the interior surface of the rim. The context of the finds supports a date sometime after the late first to mid-third-early fourth century.

D35.1. BLB12/32/1: Rim, d. 34. Local Fabric 1: Soft pale brown fabric with white and yellow lime inclusions; unslipped smooth surfaces. Context: Bulebel SU 32, Phase 2.

D35.2. MLT84/49979: Rim, d. 42. Local Fabric 1: Coarse pale brown fabric with white lime inclusions; unslipped surfaces with red-painted lines on interior surface near rim. Context: Melita SU 1097, Phase 5.

### Large bowls/mortaria (D36-D53)

This category covers a wide range of large bowls and mortar-like vessels. Roman flanged mortaria with thick walls and embedded grits are not common on Maltese sites, and no local imitations vaguely resembling this characteristic Roman form are known.<sup>14</sup> The closest thick-set vessels that may have replaced the task of a mortarium belong to a series of thick-walled coarse ware bowls with wide, heavy disc bases, some with radiating incisions on the underside of the base (see type D52), known from the sanctuary at Tas-Silġ (Quercia 2004-2005, fig. 10.2) and the Żejtun villa (Anastasi 2010, fig. 138.4).

<sup>14</sup> The only documented presence of imported mortaria on Malta belongs to a cargo of large Italian mortaria from the remains of a shipwreck within the Mellieħa Bay area, in the north-east of Malta (see Frost 1969).

### D36. Coarse ware basin type 1 (Figure 66)

This group loosely includes a range of large coarse ware bowls with sloping or flat-topped rims, some with an additional overhang (D36.2). Large bowls similar to these are common on domestic and ritual sites throughout Malta, and date to the Punic period. Quercia drew up a preliminary classification of the Late Punic large bowls (*bacini*) from Tas-Silġ and proposed a long chronology, dating between the sixth-fifth century BC to the first century AD (Quercia 2004-2005: 245, fig. 10, types 9-10). Sagona has also identified similar examples from the University of Malta's excavations at the same site (Sagona 2015, figs 1.76-77).

D36.1. BLB12/58/7: Rim, d. 36. Local Fabric 1: Pale red fabric with white and yellow lime inclusions; unslipped. Context: Bulebel SU 58, Phase 1.

D36.2. BLB12/58/27: Rim, d. 32. Local Fabric 1: Coarse pale orange fabric with white and yellow lime and foraminifera inclusions; unslipped; over-fired. Context: Bulebel SU 58, Phase 1.

D36.3. BLB12/57/1: Rim, d. 30. Local Fabric 2: Dark orange fabric with fine black glauconite inclusions; unslipped. Context: SU 57, Phase 1.

D36.4. BLB12/58/5: Rim, d. 46. Local Fabric 2: Dark orange fabric with white lime, foraminifera and black glauconite inclusions; unslipped. Context: Bulebel SU 58, Phase 1.

D36.5. BLB12/55/17: Rim, d. 56. Local Fabric 2 (Figure 22): Pale orange fabric with white and yellow lime and fine black glauconite inclusions; unslipped. Context: Bulebel SU 55, Phase 1.

D36.6. BLB12/45/1: Rim, d. 44. Local Fabric 2: Coarse pale green (under-fired?) fabric with white lime and fine black glauconite inclusions; unslipped. Context: Bulebel SU 45, Phase 2.

**D37. Coarse ware basin type 2 (Figure 66)**

This basin appears shallower and contains a hooked triangular rim. This particular shape was not common, but is similar to Quercia's type 10 (Quercia 2004-2005, fig. 10.10). This form appears to date to before the end of the first century AD.

D37.1. BLB12/58/6: Rim, d. 36. Local Fabric 2: Dark orange fabric with white lime and black glauconite inclusions; unslipped, mottled salt skin. Context: Bulebel SU 58, Phase 1.

D37.2. BLB12/58/6a: Rim, d. 40. Local Fabric 2: Pale red fabric with fine white lime, foraminifera and black glauconite inclusions; unslipped. Context: Bulebel SU 58, Phase 1.

**D38. Coarse ware basin type 3 (Figure 67)**

This category covers a range of similar rim shapes which are characterised by an everted triangular, arrow-like rim. In general, all the examples illustrated here were recovered from contexts that date to between the end of the first and the early-mid- third century AD. Sherds similar to these forms were recorded in the material from the 1972 excavations at the Żejtun villa, one in Local Fabric 2 and one in Local Fabric 6, originally classified as an import (Anastasi 2010, fig. 136.4-5). A rim similar to sherd **D38.4** was recorded amongst the Roman-period material from the excavations at Hal Millieri (Blagg, Bonnano and Luttrell 1990, fig. 14.42), whilst rims similar to **D38.1**, in Local Fabric 3, were recovered from the Bidnija area (Docter *et al.* 2012: 127-128, fig. 22.16), and also at Borġ in-Nadur (Anastasi 2011: 164-165, fig. 5.2), and are tentatively dated to the Roman period.

D38.1. BLB12/32/6: Rim, d. 48. Local Fabric 2: Pale red fabric with white lime, foraminifera and black glauconite inclusions; unslipped. Context: Bulebel SU 32, Phase 2.

D38.2. BLB12/23/6: Rim, d. 44. Local Fabric 1: Coarse orange fabric with thick pale grey core, with yellow/white lime inclusions; unslipped. Context: Bulebel SU 23, Phase 2.

D38.3. FRM08/42/52: Rim, d. 38. Local Fabric 1: Pale brown fabric with fine white lime, foraminifera and large red inclusions; salt-slipped cream surfaces. Context: Foreman Street SU 42.

D38.4. FRM08/42/50: Rim, d. c. 40. Local Fabric 2: Pale red fabric mixed with yellow clay or fine yellow lime inclusions, foraminifera and fine red and black glauconite inclusions; unslipped pale grey skin. The sherd was too small to get a more accurate diameter. Context: Foreman Street SU 42.

**D39. Coarse ware basin type 4 (Figure 67)**

This large bowl has a similar sharp and angled triangular rim to the previous type but has been classed separately because this form can clearly be linked to the Foreman Street production zone. All the examples are made using the typical Local Fabric 2 clay used in practically all the other products discovered in this area. No complete profiles or associated bases were recovered for this particular form. No close parallels are known locally but the form can be confidently dated to the end of the second-early-mid-third century AD.

D39.1. FRM08/42/54: Rim, d. 40. Local Fabric 2: Gritty dark grey fabric with burnt foraminifera, lime and glauconite inclusions; unslipped; over-fired. Context: Foreman Street SU 42.

D39.2. FRM08/42/48: Rim, d. 43. Local Fabric 2: Pale brown/pink fabric with foraminifera, white lime, red ore, few angular gypsum and black glauconite inclusions; unslipped pale cream skin. Context: SU 42.

**D40. Coarse ware basin type 5 (Figures 67 and 68)**

This large bowl is a variant of the previous type but the rim edge is rounded and contains a more pronounced bead along the rim. The fabric and proposed date are the same as type **D39**.

D40.1. FRM08/59/10: Rim, d. 46. Local Fabric 2: Gritty red fabric with thick dark grey core with white foraminifera, fine lime red ore, some fine gypsum and round black glauconite; white salt skin. Context: Foreman Street SU 59.

D40.2. FRM08/57/21: Rim, d. 36. Local Fabric 2: Hard, gritty pale red fabric with fine white foraminifera, white lime, red ore and round glauconite inclusions; unslipped grey skin; waster. Context: Foreman Street SU 57.

D40.3. FRM08/42/53: Rim, d. 36. Local Fabric 2: Hard, gritty grey fabric with white foraminifera, lime and black glauconite inclusions; unslipped; over-fired. Context: Foreman Street SU 42.

D40.4. FRM08/42/49: Rim, d. 42. Local Fabric 2: Hard, gritty pale red fabric with lots of fine yellow lime halos, with foraminifera, red ore and black glauconite inclusions; unslipped. Context: Foreman Street SU 42.

D40.5. FRM08/57/22: Rim, d. 48. Local Fabric 2: Hard pale red/pink fabric with fine foraminifera, fine red ore and black glauconite inclusions; unslipped grey skin. Context: Foreman Street SU 57.

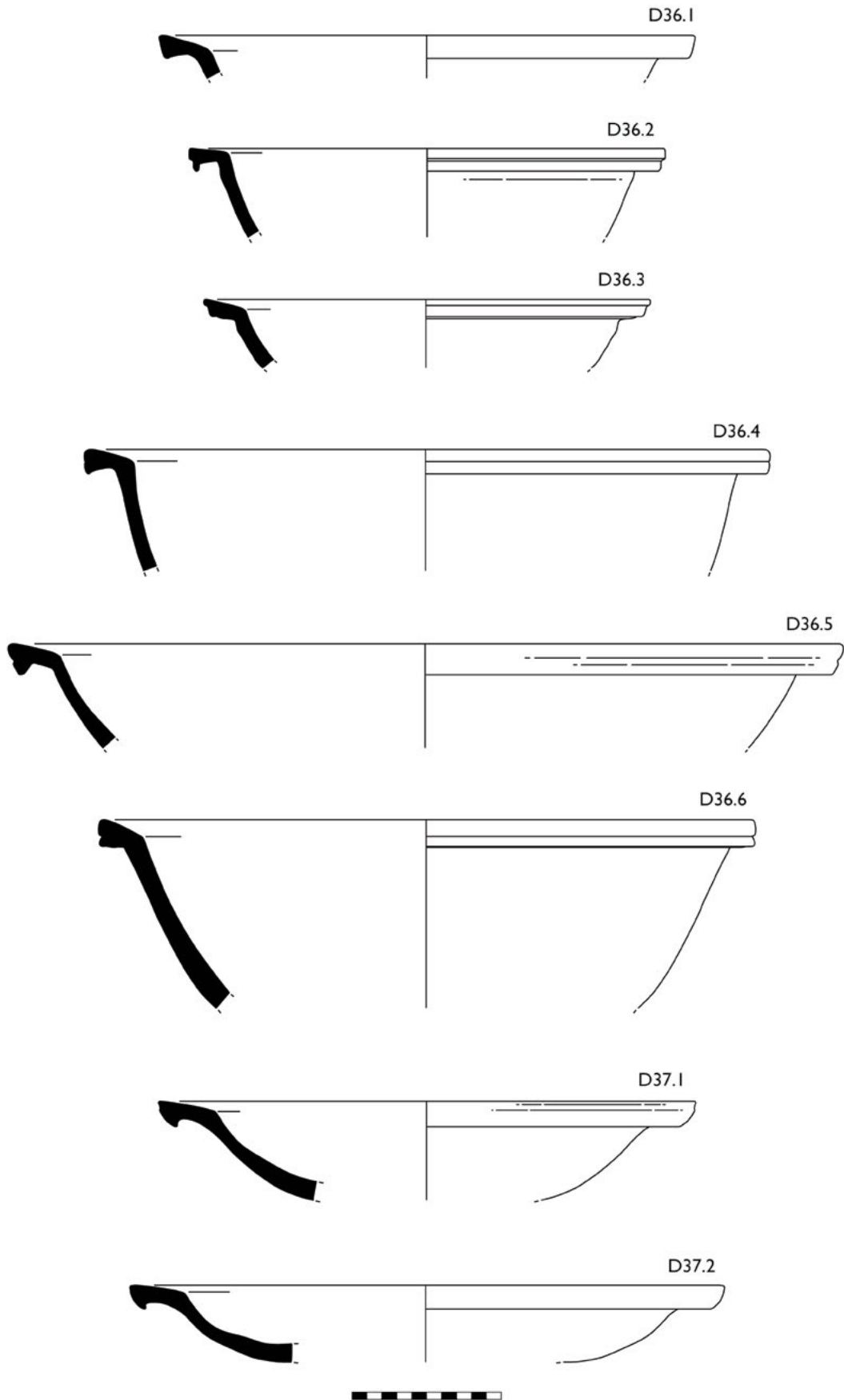

Figure 66: Coarse ware large bowl forms (D36-D37).

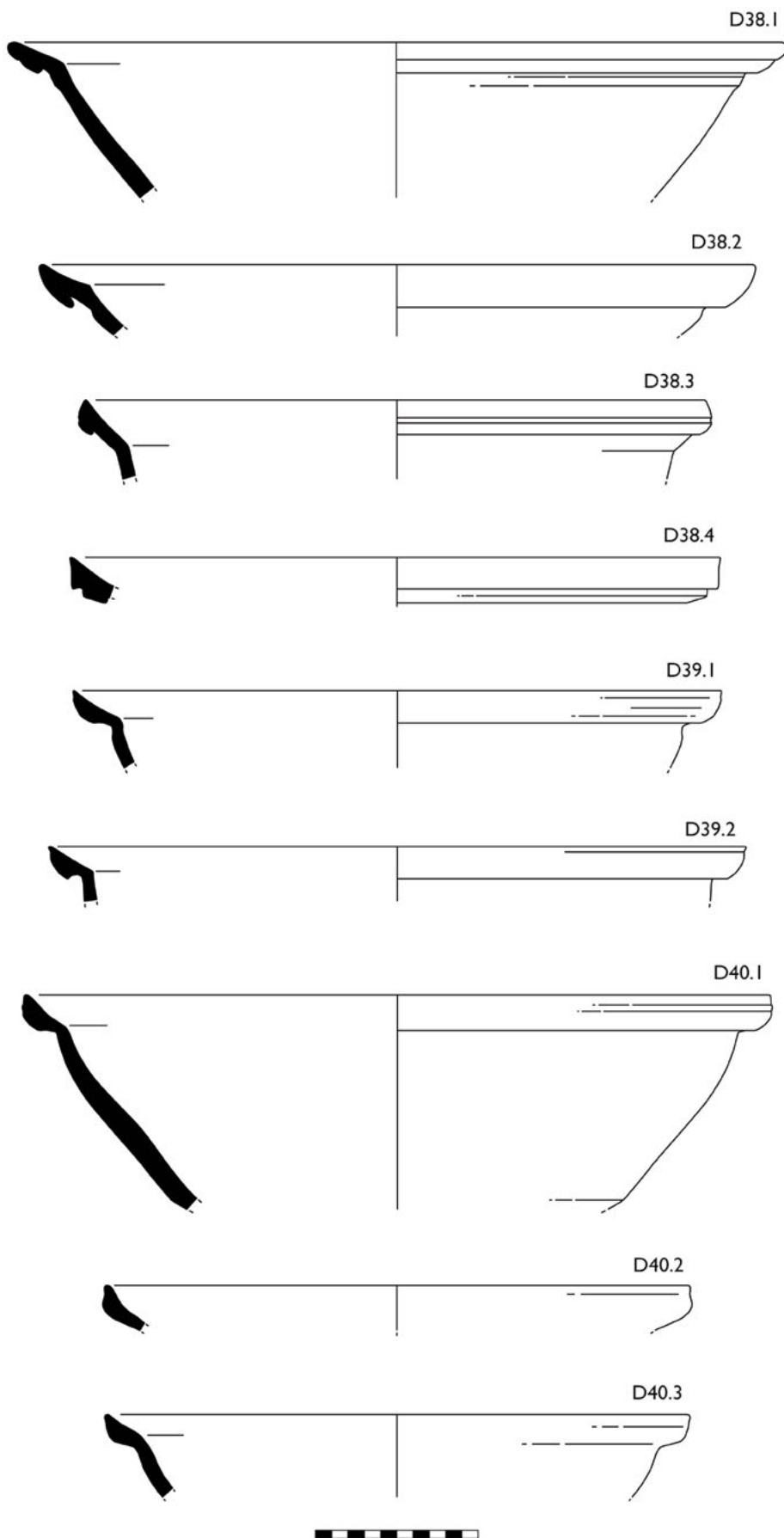

Figure 67: Coarse ware large bowl forms (D38-D40).

**D41. Coarse ware basin type 6 (Figure 68)**

A plain and sharply everted almond rim characterises this form of large bowl. A date for this particular variant is presumably similar to the previous two forms, although an example from Melita did come from a context dated to the first half of the second century. This generic bowl form was recovered in significant numbers from both Foreman Street and Bulebel, although a close look at the fabrics indicates that the forms present at the two sites did not originate from the same production site. The Gozitan variant is generally thicker and is most probably a product of the island itself. One other rim sherd resembling this large bowl, in Local Fabric 2, came from Għar ix-Xiħ (Quercia and Anastasi 2008-2009: fig. 14.1). Maltese examples can be seen within the Ħal Millieri Roman-period material (Blagg, Bonanno and Luttrell 1990: 61, fig. 15.71-72).

- D41.1. FRM08/42/58: Rim, d. 42. Local Fabric 2: Gritty pale brown fabric with white lime, foraminifera, red ore and black glauconite inclusions; unslipped. Context: Foreman Street SU 42.
- D41.2. FRM08/59/14: Rim, d. 40. Local Fabric 2: Pale red/pink fabric with fine white foraminifera, white lime, fine red ore and black glauconite inclusions; unslipped. Context: Foreman Street SU 59.
- D41.3. MLT84/24747: Rim, d. 44. Local Fabric 1: Pale orange fabric with white lime and foraminifera; mottled salt-slipped surfaces. Context: Melita SU 1062, Phase 5.
- D41.4. MLT84/26864: Rim, d. 48. Local Fabric 1: Coarse orange fabric with white lime and foraminifera inclusions; pale green/cream skin. Context: Melita SU 1075, Phase 3.

**D42. Coarse ware basin type 7 (Figures 68 and 69)**

This category loosely classes a deep krater-like vessel that has a sharply everted and elongated rim. No complete, or at least longer profiles were recovered, making it difficult to comment further on the shape. The shape does not appear to be common in Punic- and early Roman-period contexts like Tas-Silġ and the Żejtun villa, although two rim sherds sharing a similar shape were recovered from the 1972 assemblage (Anastasi 2010, fig. 137.2-3). The near absence of this general form in contexts pre-dating the end of the first-the first half of the second century AD supports its Roman date. A form resembling variant **D42.6**, with straight, sharply sloping walls, can be identified at Berenice, classed as MRCW 1, and tends to become popular at the site from the first half of the second century AD (Riley 1979: 339, fig. 125). The slightly concave lower wall noticed for variants **D42.3-4** shares a general shape to the deep jars

from Late Roman contexts at Carthage (Hayes 1976: 102, fig. XIV.39-40).

- D42.1. FRM08/42/51: Rim, d. 26. Local Fabric 2: Gritty pale red fabric with thick pale grey core, with fine white lime, foraminifera, fine gypsum and black glauconite inclusions; grey/white salt skin. Context: Foreman Street SU 42.
- D42.2. FRM08/57/24: Rim, d. 28. Local Fabric 2: Dark grey fabric with white lime, foraminifera and round black glauconite inclusions; unslipped; over-fired; traces of burning/soot. Context: Foreman Street SU 57.
- D42.3. FRM08/59/15: Rim, d. 36. Local Fabric 2: Pale brown fabric with white foraminifera, lime, red ore, grog and black glauconite inclusions; unslipped. Context: Foreman Street SU 59.
- D42.4. MLT84/26095: Rim, d. 36. Local Fabric 3: Hard orange fabric with white lime and angular gypsum inclusions; unslipped cream salt skin. Context: Melita SU 1096, Phase 5.
- D42.5. MLT84/26882: Rim, d. 40. Local Fabric 2: Hard orange fabric with white lime and glauconite inclusions; cream exterior. Context: Melita SU 1075, Phase 3.
- D42.6. MLT84/49870: Rim, d. 44. Local Fabric 1: Hard pale orange fabric with white lime and red ore/grog inclusions; unslipped pale orange surface. Context: Melita SU 1085, Phase 3.

**D43. Coarse ware basin type 8 (Figure 69)**

Only one example of this form was recorded in the assemblages and it is characterised by inward-curving walls with a thickened, rounded rim. At least three rims similar to this come from Tas-Silġ and are classed as 'Red Brickly ware' by Sagona (Sagona 2015, fig. 1.120:2-4). These examples fall into Tas-Silġ phases IV and V, dateable to between the third century BC and the fifth century AD. A more specific date is unknown. The rim from Melita comes from a context dated to the mid-third-mid-fourth century (Phase 5) and no other local parallels are known.

- D43.1. MLT84/26148: Rim, d. 24. Local Fabric 1: Pale orange fabric with white lime and foraminifera inclusions; pale grey salt-slipped exterior. Context: Melita SU 1096, Phase 5.

**D44. Coarse ware basin type 9 (Figures 69 and 70)**

Three rim sherds belonging to this form were identified and belong to a vessel exhibiting a straight and thick-walled deep bucket-like form with a thick collared rim. The clay is that of Local Fabric 1 and the form resembles

some Late Punic vessels recorded at Tas-Silġ, classed as a Phase IV Hellenistic/Early Roman 'situla' with a similar fabric and finish (Sagona 2015, fig. 1.87:4).

D44.1. MLT84/26275: Rim, d. 38. Local Fabric 1: Pale orange fabric with a thin pale grey core, with white lime and foraminifera inclusions; cream salt-slipped exterior; smoothed and well finished. Context: Melita SU 1100, Phase 2.

#### D45. Coarse ware basin type 10 (Figure 69)

This type of deep basin has sloping walls with a thick doubled-stepped rim. The majority of the examples recorded were made using Local Fabric 1 – although one is in Local Fabric 2 – and are all associated with contexts dated to after the late first century AD (Melita Phase 1 onwards). This particular style was only found in the Melita assemblage, although a similar vessel, with a very similar fabric to **D45.5** was recorded at the Żejtun villa (Anastasi 2010, fig. 136.2). None of these kinds of vessels was recovered from any tomb contexts and they appear to be mostly common at domestic sites.

D45.1. MLT84/49331: Rim, d. 40. Local Fabric 1: Pale orange fabric with a thick grey core, with white and yellow lime and foraminifera inclusions; grey/cream-coloured salt-slipped exterior surfaces. Context: Melita SU 1084, Phase 4.

D45.2. MLT84/49987: Rim, d. 40. Local Fabric 1: Coarse pale orange fabric with yellow lime and foraminifera inclusions; cream-coloured salt-slipped exterior. Context: Melita SU 1097, Phase 5.

D45.3. MLT84/23210.3: Rim, d. 50. Local Fabric 2: Pale cream/grey fabric with white lime, foraminifera and fine black glauconite inclusions; unslipped. Context: Melita SU 1024.

D45.4. MLT84/49630: Rim, d. 52. Local Fabric 1: Coarse pale grey fabric with white lime and foraminifera inclusions; unslipped, pale grey/cream skin. Context: Melita SU 1103, Phase 5.

D45.5. MLT84/24744: Rim, d. 48. Local Fabric 1: Pale green clay with white and yellow lime and foraminifera inclusions; unslipped. Context: Melita SU 1062, Phase 5.

#### D46. Coarse ware basin type 11 (Figures 69 and 70)

This category groups a series of large bowls similar in shape to the ones above (**D6-7**), but larger in dimension. The shape is characterised by a large simple hemispherical vessel, some with a wide, flat base and simple rounded and slightly flaring rim (**D46.1**), a triangular rim (**D46.2**) or straight and bevelled (**D46.3-**

**5**). The dating varies for each variant: the earliest appears to be example **D46.1**, dating to sometime before the mid-end of the first century. The remaining variants are associated with finds dating to between the late first century and early-mid-third century.

D46.1. BLB12/58/12: Profile, d. 26 (rim), d. 13.5 (base). Local Fabric 1: Pale orange fabric with fine white lime and foraminifera inclusions; shallow ribbed exterior; cream-coloured skin; rough, string-cut base. Context: Bulebel SUs 58 and 55, Phase 1.

D46.2. BLB12/43/1: Rim, d. 26. Local Fabric 2: Orange fabric with fine white lime, foraminifera and black glauconite inclusions; unslipped pale pink surface. Context: Bulebel SU 43, Phase 2.

D46.3. FRM08/42/46: Rim, d. 26. Local Fabric 2: Pale red fabric with thick grey core, with white lime, foraminifera, angular gypsum and black volcanic inclusions; grey/cream salt-slipped surfaces; rilled interior wall. Context: Foreman Street SU 42.

D46.4. FRM08/42/47: Rim, d. 24. Local Fabric 2: Hard pale orange fabric with thick grey core, with foraminifera, lime and black glauconite inclusions; grey/cream-coloured skin; rilled interior wall. Context: Foreman Street SU 42.

D46.5. FRM08/42/45: Rim, d. 26. Local Fabric 2: Hard orange clay with fine white lime, foraminifera, and black glauconite inclusions; unslipped. Context: Foreman Street SU 42.

#### D47. Coarse ware basin type 12 (Figure 70)

This large bowl is characterised by a sharply inverted simple rim and is known on Late Republican/Early Imperial-period sites across Malta. One large example was recorded at Żejtun (Anastasi 2010, fig. 137.7). None have been recorded on Gozo or in tomb contexts to date. The rim width varies quite considerably (between 18 and 30 cm, and larger), but generally all examples are made using Local Fabric 2. The vessels are unslipped but the salt in the clay does leach to the exterior surface during firing giving the vessel a mottled pink and cream colour. One example from Bulebel contained an oval-section horizontal loop handle attached either side of the vessel, flush with the rim (**D47.1**). This form is absent from the Tas-Silġ assemblage and is associated with early Roman domestic contexts such as the Żejtun villa, San Pawl Milqi villa, Bulebel and Melita. Secure dating is poor, but an early first century AD date is suggested for the start of its presence at Bulebel.

D47.1. BLB12/24/10: Rim and handle, d. 23. Local Fabric 2: Pale orange/pink fabric with white lime,

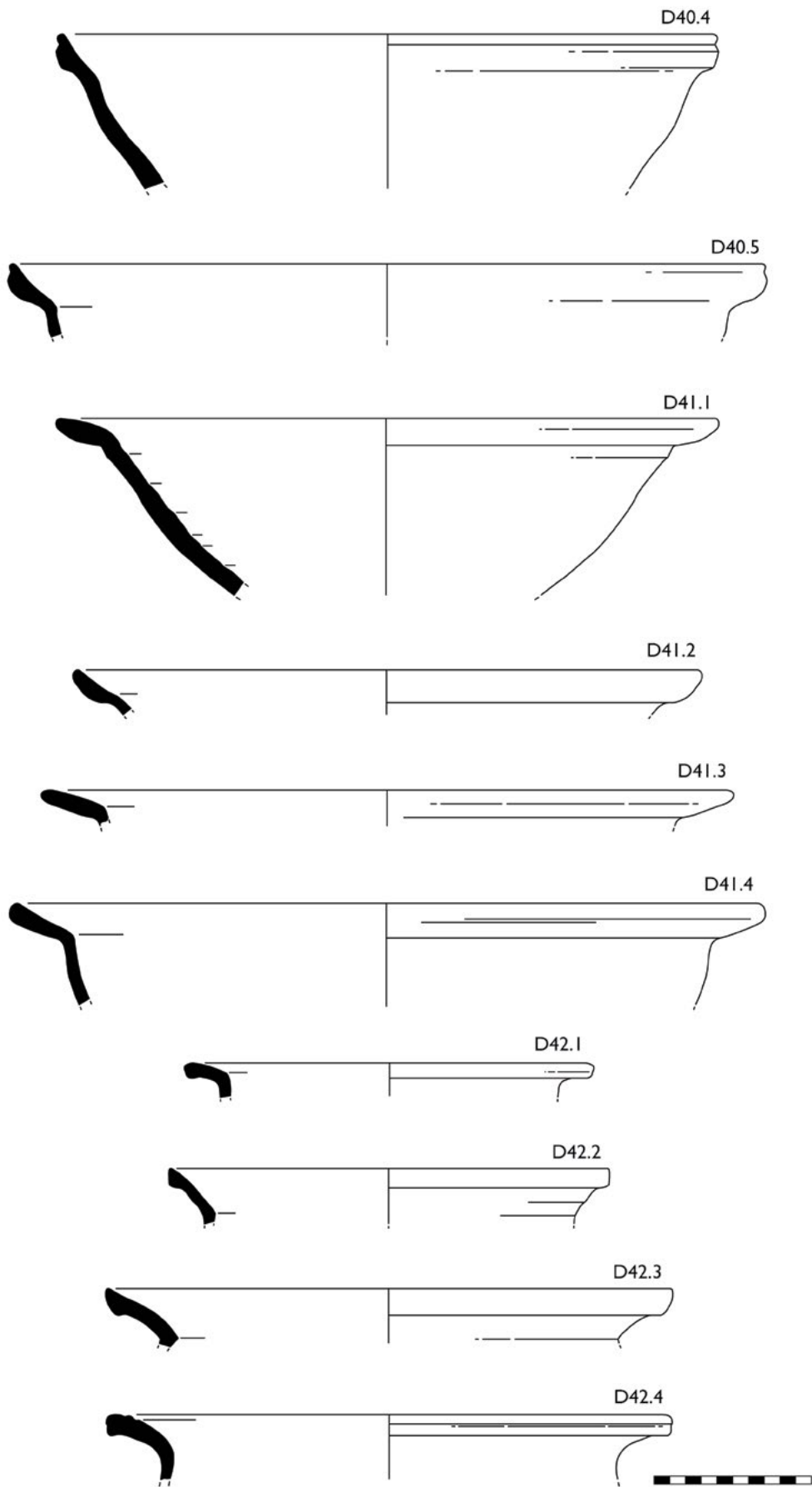

Figure 68: Coarse ware large bowl forms (D40-D42).

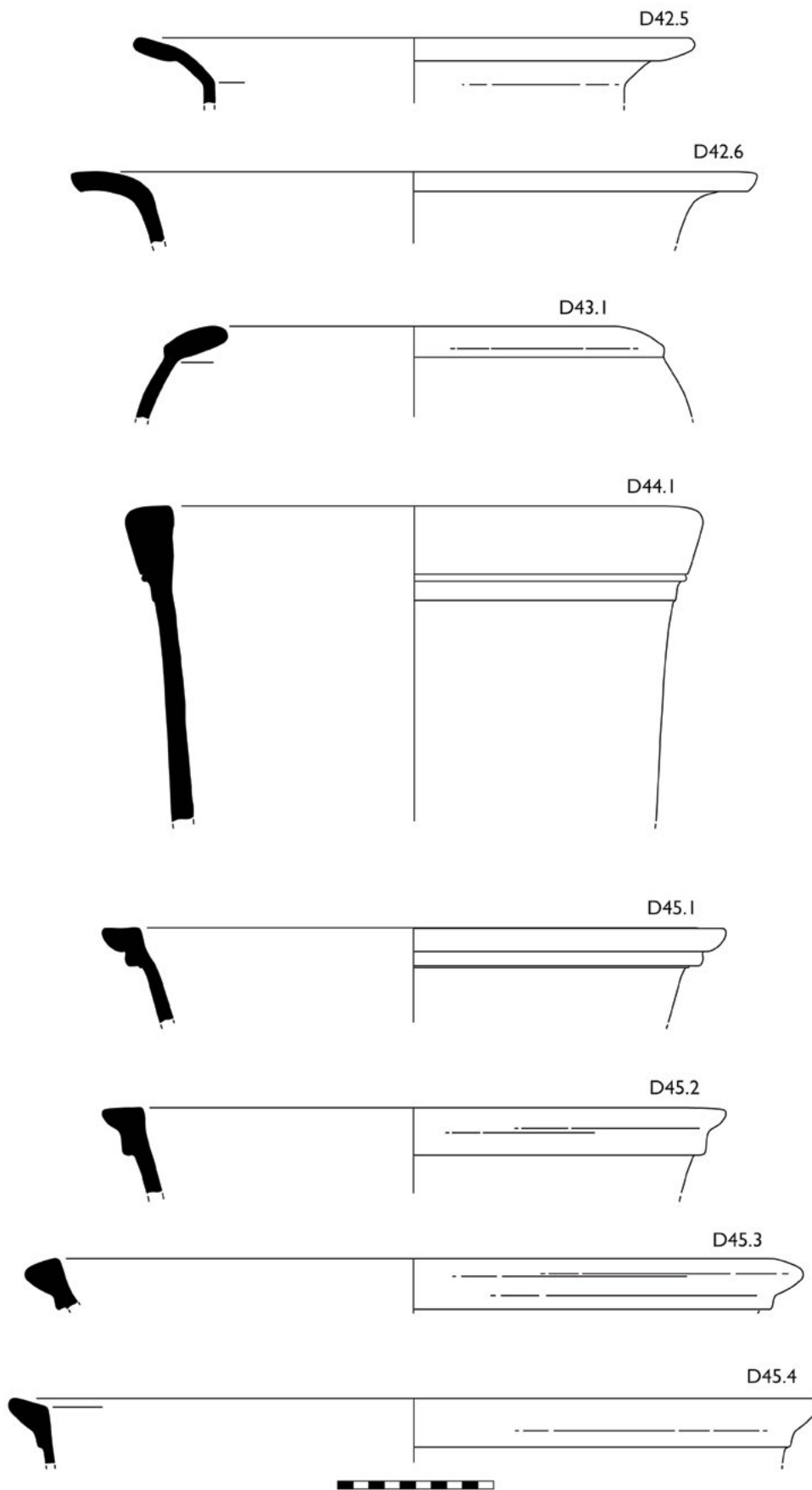

Figure 69: Coarse ware large bowl forms (D42-D45).



foraminifera and black glauconite inclusions; unslipped; oval-section horizontal strap handle attached to rim. Context: Bulebel SU 24, Phase 2.

D47.2. BLB12/58/37: Rim, d. 18. Local Fabric 2: Hard pale orange fabric with fine white lime, foraminifera and round black glauconite inclusions; unslipped cream skin; Context: Bulebel SU 58, Phase 1.

#### D48. Coarse ware basin type 13 (Figure 70)

Only two rims belonging to this form were identified from the Foreman Street assemblage. The hooked-rim form is not common on Maltese sites, but is a common Roman-period North African form (Hayes 1976, fig. X.10, Early Roman bowl type 1; Fulford 1994, fig. 14, type 8). The Carthaginian examples came from contexts dating to after the fourth century, however recent excavations of coarse ware kilns in Utica are indicating that bowls of this form were being produced from at least the first-second century. The Gozitan examples are made in Local Fabric 2 and are provisionally dated to the late second-mid-third century AD. This bowl should not be confused with a similar local cooking ware bowl (C11). The cooking ware form is also common on domestic early Roman sites like the Żejtun villa, and is possibly an imitation of similar Italian Pompeian Red ware dishes (Anastasi 2010, fig. 143.1-6).

D48.1. FRM08/59/21: Rim, d. 19. Local Fabric 2: Hard pale red fabric with fine white foraminifera, lime and occasional black glauconite inclusions; unslipped cream-coloured salt skin. Context: Foreman Street SU 59.

D48.2. FRM08/42/91: Rim, d. 24. Local Fabric 2: Hard pale red/brown fabric with fine white lime, foraminifera, red ore and fine black glauconite inclusions; unslipped cream-coloured salt skin. Context: Foreman Street SU 42.

**D49. Coarse ware basin type 14 (Figure 70)** This almond-rimmed bowl or lid form is a smaller version of the large bowl types **D39-40**, found only at Foreman Street. The presence of a waster (**D49.6**) suggests that this form is a local product, and can be dated to the end of the second to early/mid-third century. All are made in Local Fabric 2. One example contained incised decoration or illegible writing on the interior surface, etched into the clay prior to firing (**D49.5**). The form could be modelled on North African cooking ware lid forms common throughout the Roman period.

D49.1. FRM08/59/11: Rim, d. 20. Local Fabric 2: Hard and gritty red fabric with yellow lime, fine white foraminifera and fine black glauconite inclusions; unslipped pale skin. Context: Foreman Street SU 59.

D49.2. FRM08/59/12: Rim, d. 20. Local Fabric 2: Hard pale red fabric with fine white lime, foraminifera and black glauconite inclusions; unslipped cream skin. Context: Foreman Street SU 59.

D49.3. FRM08/42/57: Rim, d. 21. Local Fabric 2: Hard red fabric with white/yellow lime, white foraminifera and black glauconite inclusions; unslipped pale skin. Context: Foreman Street SU 42.

D49.4. FRM08/42/56: Rim, d. 20. Local Fabric 2: Pale red/pink fabric with large white lime, foraminifera and fine black glauconite inclusions; unslipped pale skin. Context: Foreman Street SU 42.

D49.5. FRM08/42/81: Rim, d. 26. Local Fabric 2: Hard, gritty red fabric with fine white foraminifera, abundant fine black glauconite and large red ore inclusions; white skin; incised decoration on interior surface. Foreman Street SU 42.

D49.6. FRM08/57/27: Rim, d. 32. Local Fabric 2: Hard gritty pale red/yellow (ruptured lime?), fired grey in parts, with foraminifera, red ore and glauconite inclusions; over-fired waster. Context: Foreman Street SU 57.

#### D50. Coarse ware basin type 15 (Figure 71)

This small group of large bowls is loosely characterised by thick walls, carinated beneath the rim, allowing a sloping, bevelled rim to curve inwards. A series of grooves and ridges striate the exterior surface. Based on the fabric and Foreman Street examples, this form can be tentatively dated to the late second-early to mid-third century. A coarse ware vessel similar in shape, and dating to the second century, was recorded at Knossos in Crete (Hayes 1983, fig. 12.161).

D50.1. BLB12/14/6: Rim, d. 36. Local Fabric 3: Pale red fabric with white lime, foraminifera, gypsum and black glauconite inclusions; cream-coloured skin. Context: Bulebel SU 14, Quarry 2.

D50.2. FRM08/59/17: Rim, d. 34. Local Fabric 2: Coarse grey fabric with white lime, foraminifera, some gypsum and glauconite inclusions; cream salt skin; over-fired? Context: Foreman Street SU 59.

D50.3. FRM08/59/18: Rim, d. 42. Local Fabric 2: Pale brown fabric with white foraminifera, pale red grog and fine black glauconite inclusions; unslipped pale skin. Context: Foreman Street SU 59.

#### D51. Coarse ware dish type 16 (Figure 71)

This category groups a series of large plates with flaring triangular rims. Large platters such as these are

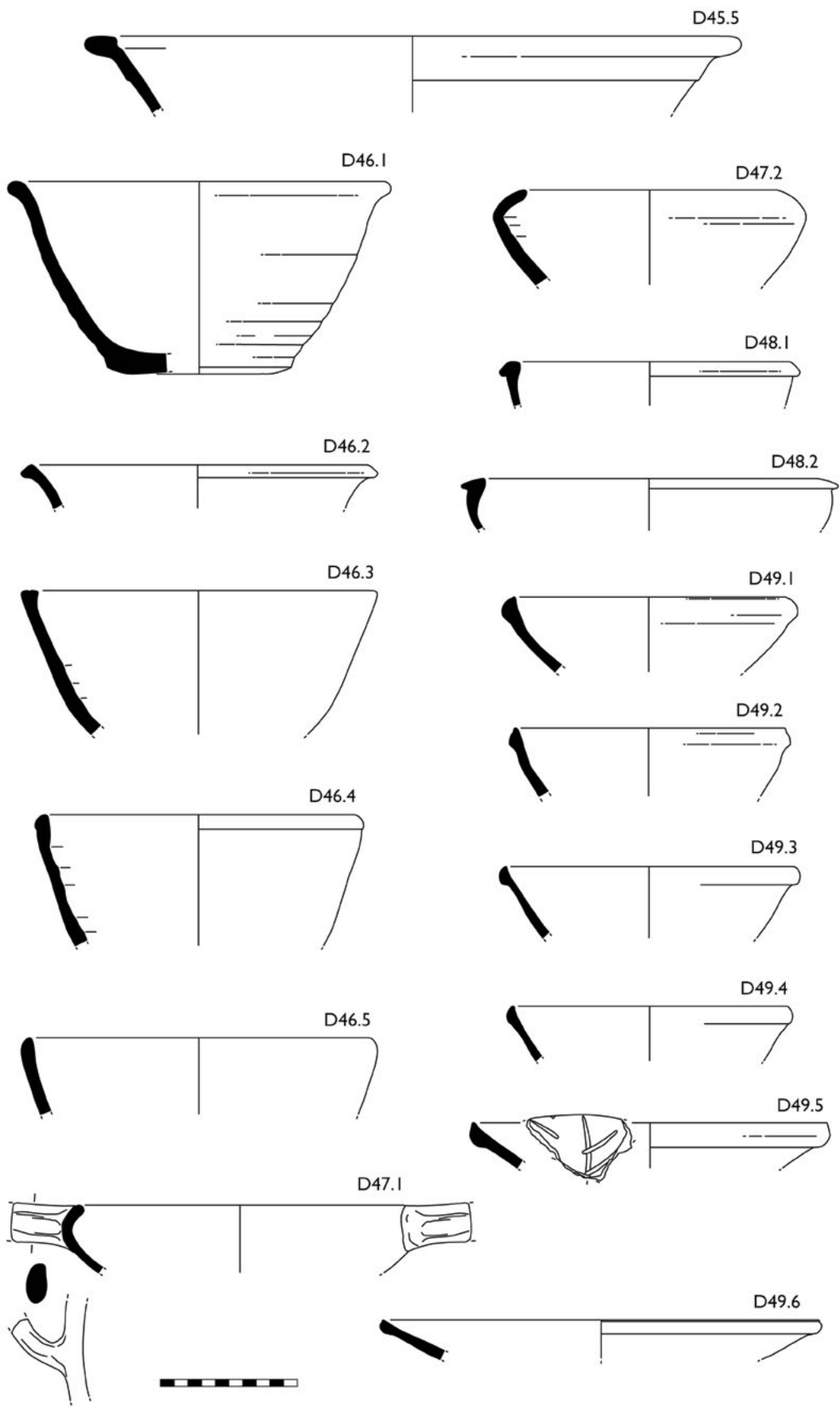

Figure 70: Coarse ware large bowl forms (D45-D49).

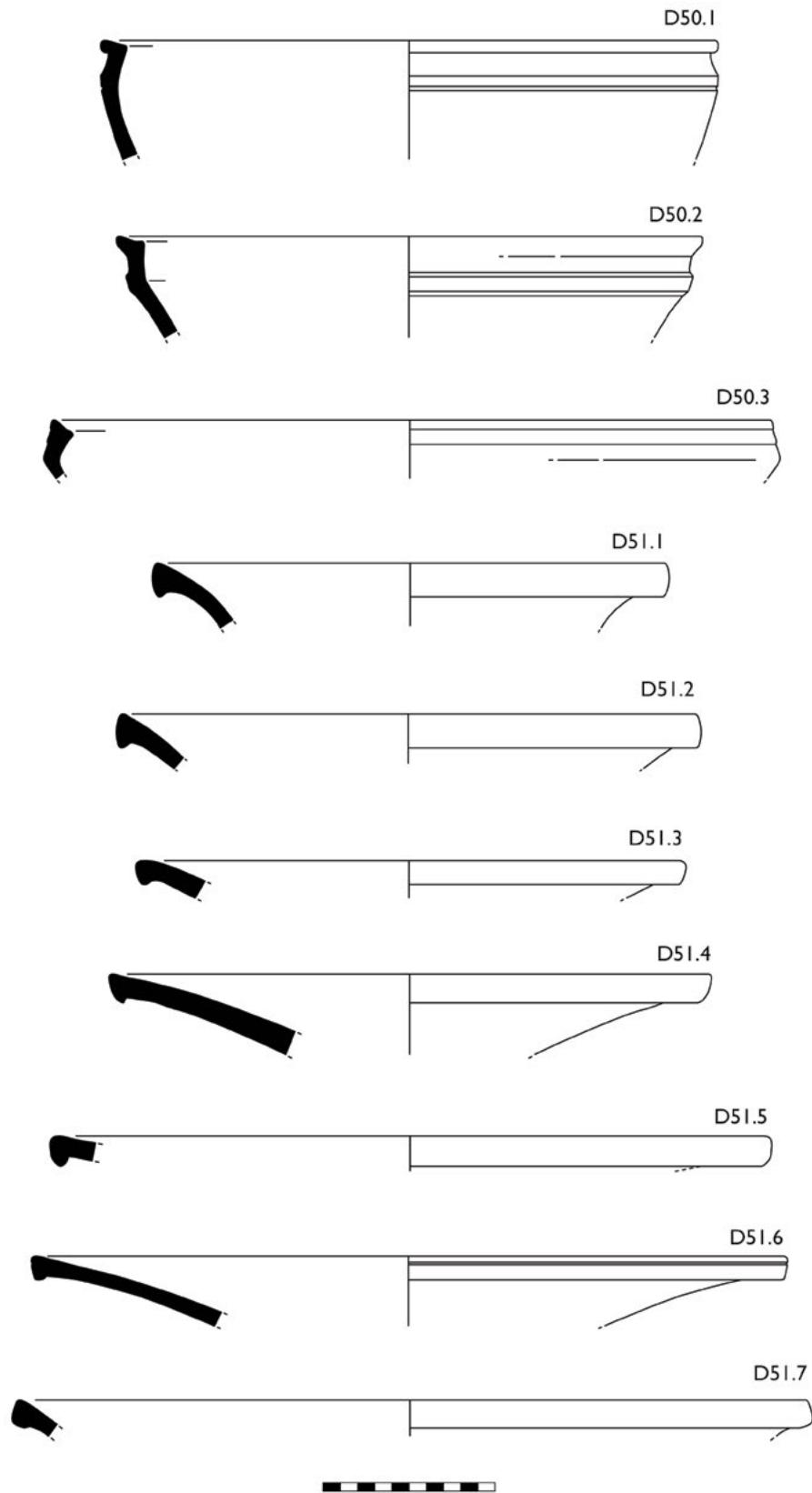

Figure 71: Large coarse ware bowl (D50) and plate (D51) forms.

common on Late Punic sites like Tas-Silġ (Quercia 2004-2005: 345, fig. 8.7), and early Roman domestic villas like the Żejtun villa (Anastasi 2010, fig. 135.15-16). Current dating evidence is limited, however the presence of these large plates in Local Fabric 3 indicates a date after the end of the first century.

D51.1. BLB12/58/8a: Rim, d. 30. Local Fabric 1: Pale brown fabric with red ore and white lime and foraminifera inclusions; unslipped. Context: Bulebel SU 58, Phase 1.

D51.2. BLB12/58/8: Rim, d. 34. Local Fabric 2: Pale orange fabric with large brown-coloured grog and fine glauconite inclusions; unslipped. Context: Bulebel SU 58, Phase 1.

D51.3. BLB12/59/1: Rim, d. 32. Local Fabric 1: Pale brown fabric with a darker grey core, with white lime and foraminifera inclusion; unslipped. Context: Bulebel SU 59, Phase 1.

D51.4. BLB12/32/32: Rim, d. 35. Local Fabric 2: Hard pale brown fabric with large white lime, foraminifera, grey grog and occasional black glauconite inclusions; unslipped. Context: Bulebel SU 32, Phase 2.

D51.5. BLB12/24/3: Rim, d. 42. Local Fabric 3: Pale brown fabric with white lime, foraminifera, lots of black shiny (glauconite?) inclusions and angular gypsum; unslipped. Context: Bulebel SU 24, Phase 2.

D51.6. BLB12/24/2: Rim, d. 44. Local Fabric 3: Buff-coloured fabric with white lime, foraminifera, gypsum and glauconite inclusions; under-fired? Context: Bulebel SU 24, Phase 2.

D51.7. FRM08/59/43: Rim, d. 46. Local Fabric 1: Hard pale brown fabric with white foraminifera, some fine gypsum, fine red ore, dark grog and occasional fine glauconite inclusions; unslipped pale surface. Fabric not typical of other Foreman Street fabrics; possibly imported from another site? Context: Foreman Street SU 59.

**D52. Coarse ware mortar type 17 (Figure 72)**

This base sherd belongs to a thick-walled, heavy set mortar-like basin that is probably the closest form that acted as a grinding mortar on the island. As stated at the start of this section, typical Late Punic and Roman mortaria are completely missing from Maltese ceramic assemblages, possibly reflecting specific nutritional or cultural habits amongst the islands' inhabitants. Several examples of base sherds were recovered from the Bulebel assemblage suggesting a date between the first and early third century AD. The characteristic radiating incisions on many bases are known from



Figure 72: Coarse ware mortar base (D52).

Tas-Silġ (Quercia 2004-2005, fig. 10.2; Sagona 2015, fig. 1.78:4) and the Żejtun villa (Anastasi 2010, fig. 138.4), indicating that they were produced from a much earlier date. The fabric (Local Fabric 3) suggests that some of these vessels were most certainly produced into the first century AD.

D52.1. BLB12/39/15: Thick mortar disc base, d. 15. Local Fabric 3: Hard pale orange fabric with white lime, foraminifera, black glass-like inclusions and angular gypsum; radiating incised lines on underside of base; unslipped pale skin. Context: Bulebel SU 39, Phase 2.

**D53. Miscellaneous large open vessels (Figure 73)**

This last group of open vessels includes a range of miscellaneous forms. Each catalogue entry contains additional comments with specific details pertaining to possible parallels and comparative dating evidence.

D53.1. BLB12/58/17: Rim, d. 52. Local Fabric 7: Coarse, soft pale brown fabric with large white and yellow lime, fine white foraminifera and pale red and grey grog inclusions; smooth wet-wiped exterior surfaces. Context: Bulebel SU 58, Phase 1. *Comment/s:* Similar to Sagona 2015, fig. 88.1-2. Date: Late Punic to the end of the second-mid-third century AD.

D53.2. FRM08/59/16: Rim, d. 54. Local Fabric 2: Hard red fabric with thick grey core, with fine white lime,

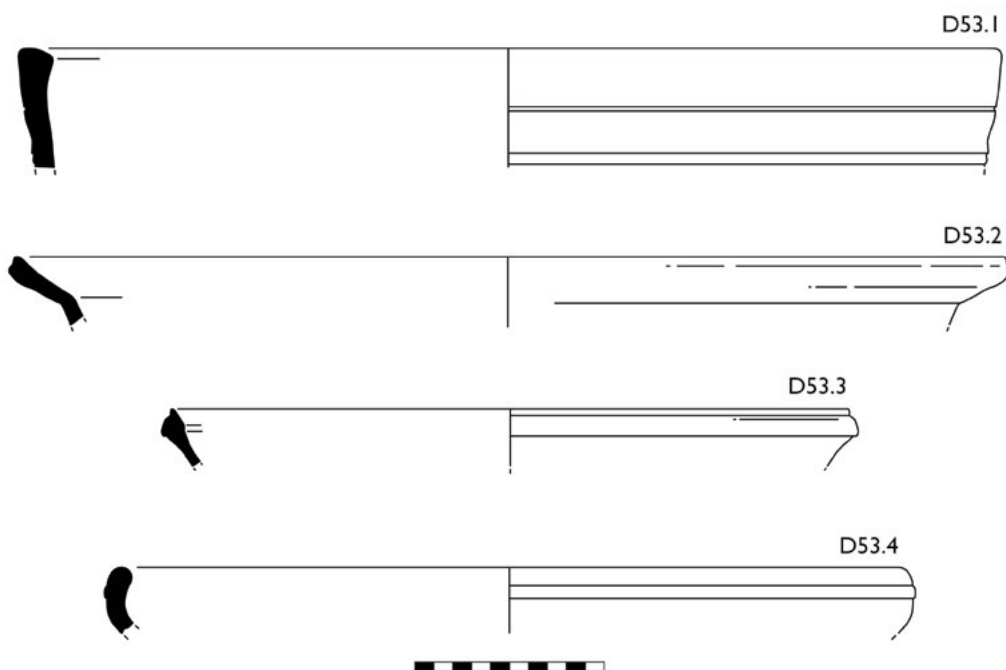

Figure 73: Miscellaneous large open coarse ware vessels (D53).

foraminifera, red ore and fine glauconite inclusions; cream salt-slipped skin. Context: Foreman Street SU 59. *Comment/s*: end of the second-mid-third century AD?

D53.3. FRM08/57/23: Rim, d. 36. Local Fabric 2: Hard red fabric with fine white lime, foraminifera and glauconite inclusions; grey/cream salt-slipped skin. Context: Foreman Street SU 57. *Comment/s*: Variant of form **D40**? end of the second-mid-third century AD.

D53.4. MLT84/49968: Rim, d. 40. Local Fabric 1: Hard pale orange fabric with large white/yellow lime and white foraminifera inclusions; unslipped. Context: Melita SU 1097, Phase 5. *Comment/s*: Mid-third-fourth century context, possibly residual.

#### *Jars and jugs (D54-D69)*

#### **D54. Punic painted closed vessels (Figure 74)**

This class consists of a range of miscellaneous Punic-period closed vessels that are characterised by a white slip beneath thin, red-painted bands. This style of decoration is typical of fifth-fourth-century BC Punic pottery, but continued until at least the mid-third-second century BC.

D54.1. BLB12/58/14: Rim, d. 12. Local Fabric 1: Pale red fabric with fine white foraminifera, large yellow lime and red ore inclusions; even pale yellow matt slip on

exterior with thin re-painted lines on neck. Context: Bulebel SU 58, Phase 1.

D54.2. MLT84/49947: Rim, d. 9. North African Fabric: Hard-fired brown fabric with quartz, large lime and dark, grog-like inclusions; cream-slipped exterior surface with red-painted bands on the neck. Context: Melita SU 1098, Phase 5; residual. *Comment/s*: Imported Punic jar of unknown type.

D54.3. BLB12/58/19: Hollow, ring base, d. 6. Local Fabric 2: Hard red fabric with a clean break with fine white foraminifera, yellow lime and fine shiny glauconite inclusions; thick, smoothed pale yellow slip on interior and exterior surface with a thick red-painted band on the lower body. Context: Bulebel SU 58, Phase 1.

D54.4. MLT84/49869: Splayed jar base, d. 10. Local Fabric 1: Fine pale orange fabric with pale yellow lime, white foraminifera and occasional red ore inclusions; smooth and polished cream slipped exterior with red painted bands on the foot. Context: Melita SU 1085, Phase 3.

D54.5. MLT84/49497: Rim, d. 20. Local Fabric 1: Coarse pale orange fabric with a thick grey core, with large yellow lime, white foraminifera inclusions; unslipped mottled, pink/orange surfaces with a thick dull red painted band on the neck. Context: Melita SU 1095, Phase 2.

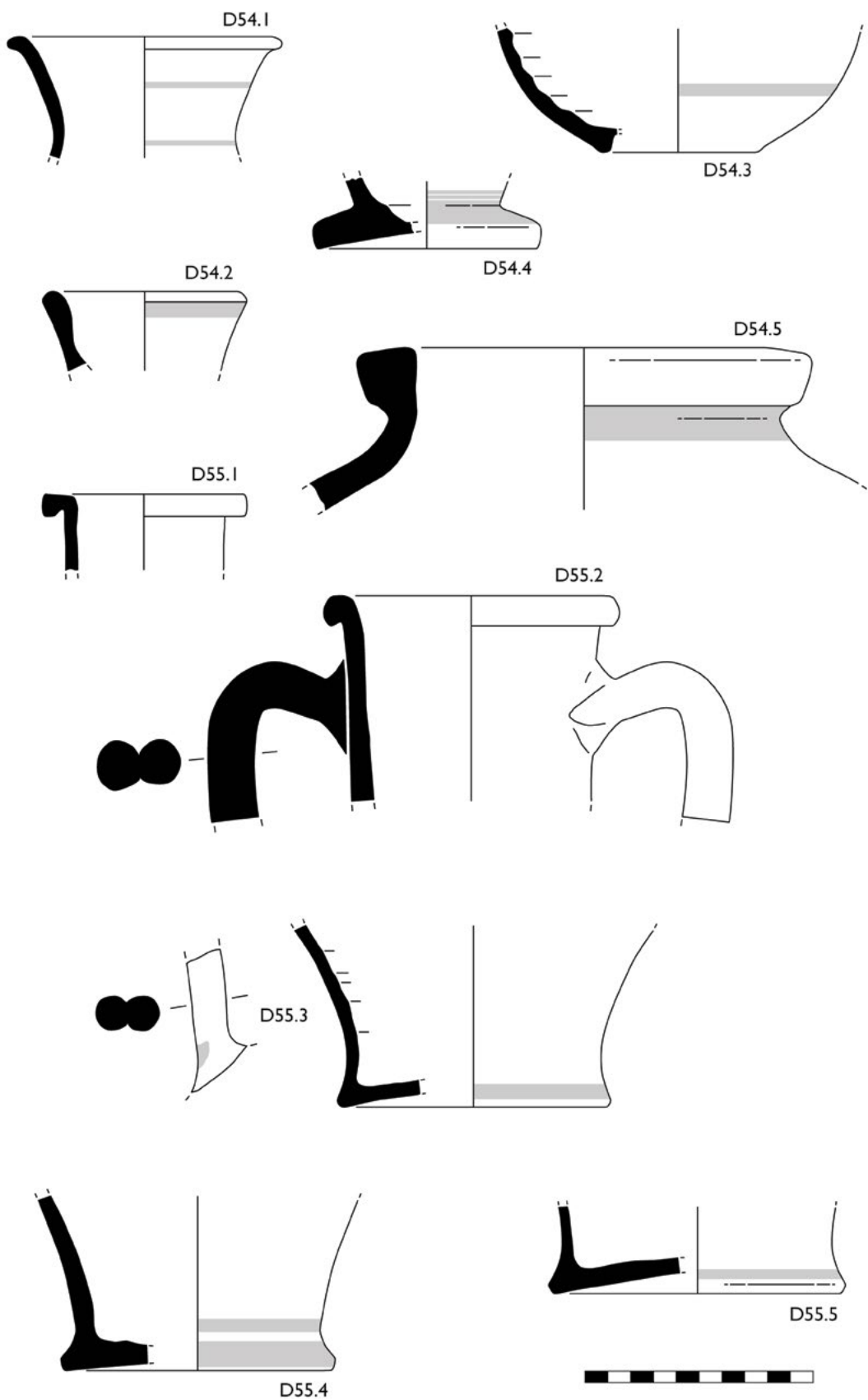

Figure 74: Coarse ware jar forms (D54-D55).

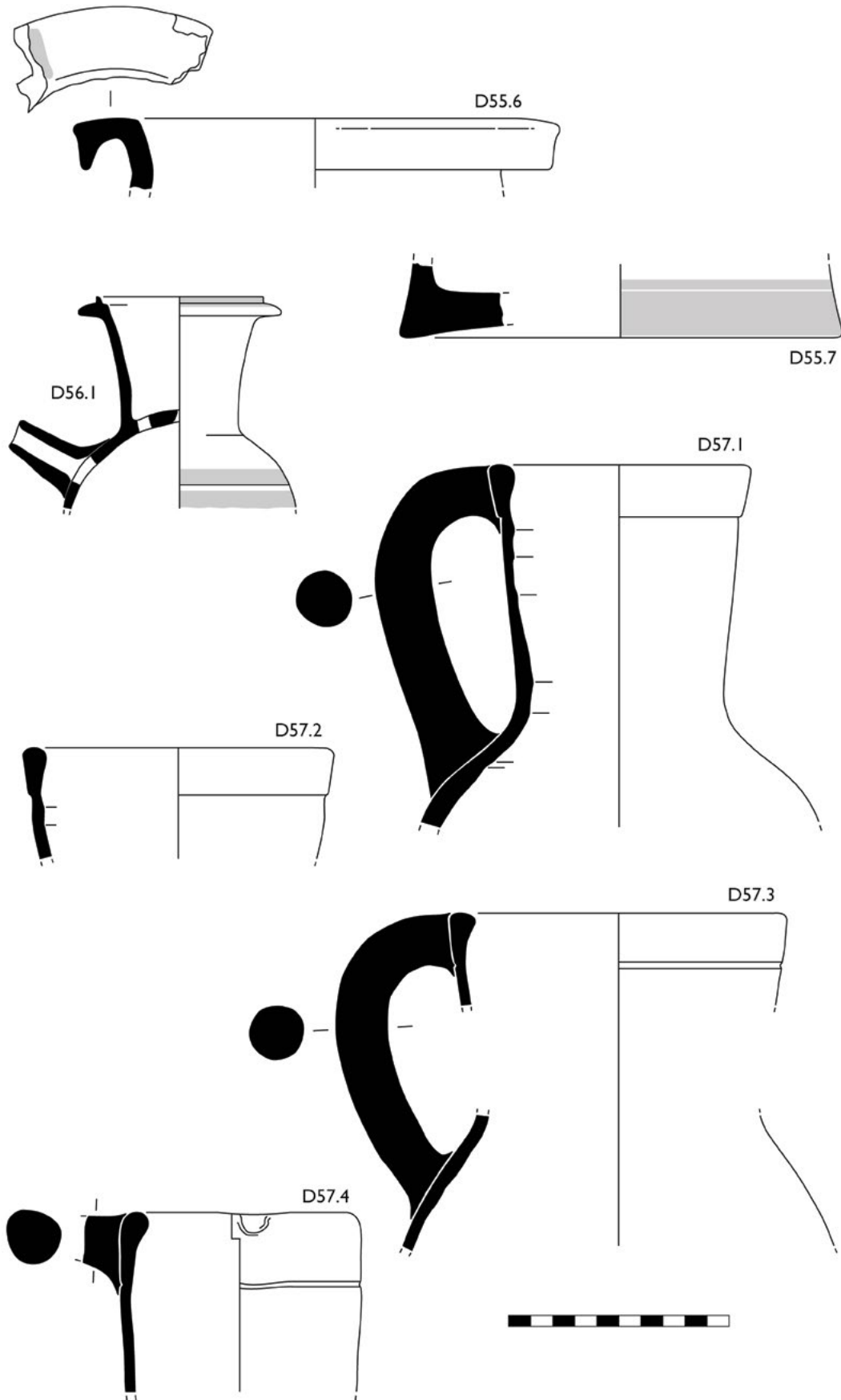

Figure 75: Coarse ware jug and jar forms (D55-D57).

**D55. Flat-bottomed amphora (Sagona urn form III-IV: 4) (Figures 74 and 75)**

This class belongs to a type of flat-bottomed table amphora. This form is essentially a fourth-third-century BC vessel, however variants did continue into the Late Republican and Early Imperial period (Anastasi 2018). The types evident in these Roman assemblages are table amphorae with flat and splayed bases with a smoothed mottled pink/cream exterior surface with one or two red-painted bands on the base. Double-cordon strap handles are associated with at least one of these bases (D55.3). The later variants, such as D55.2, resemble Dressel 2-4 types and may be consistent with local wine-related containers. Unfortunately, more base than rim fragments were recovered making it difficult to determine the exact form types. However the restricted number of sherds within the earliest first century Phase at Bulebel, together with the presence of Local Fabric 2 varieties, supports the possibility that these forms continued, albeit in limited numbers, into the early Imperial period.

D55.1. MLT84/49488: Rim, d. 9. Local Fabric 1: Hard pale orange fabric with coarse yellow lime and foraminifera inclusions; smooth, burnished cream exterior surfaces. Context: Melita SU 1094 and 1095, Phase 3.

D55.2. BLB12/32/36: Rim, neck and handle, d. 13. Local Fabric 2: Hard-fired red clay with a thin grey core with fine white and yellow microforaminifera, lime and occasional, fine black glauconite inclusions; Even, matt pale yellow exterior surface. Context: Bulebel SU 32, Phase 2.

D55.3. BLB12/32/44 Base, handle, d. 12. Local Fabric 2: Hard red gritty fabric with fine yellow lime, white foraminifera and abundant black glauconite inclusions; thin, smooth pale yellow to pink slip/skin on exterior surface with a thin pale red, painted band on the base and lentil dashes painted horizontally across the handle. Context: Bulebel SU 32, Phase 2.

D55.4. BLB12/32/50: Base, d. 12. Local Fabric 2: Hard dark orange fabric with fine yellow lime, white foraminifera and fine black glauconite inclusions; smoothed pale yellow/cream exterior slipped surface. Context: Bulebel SU 32, Phase 2.

D55.5. BLB12/32/43: Base, d. 13. Local Fabric 2: Hard-fired brown/orange fabric with fine white lime and foraminifera and fine black glauconite inclusions; pale unslipped pink/brown skin with faint, red/brown band painted on the base. Context: Bulebel SU 32, Phase 2.

D55.6. MLT84/49591: Rim, d. 22. Local Fabric 1: Hard pale orange fabric with fine yellow lime and foraminifera inclusions; smooth cream-slipped exterior surface with radiating red-painted lines on the flat-topped rim. Context: Melita SU 1109, Phase 5; residual?

D55.7. MLT84/49937: Base, d. 20. Local Fabric 1: Hard orange fabric with a thin grey core and contains white foraminifera and white lime inclusions; thick cream exterior surface with red-painted bands on the base. Context: Melita SU 1098, Phase 5; residual?

**D56. Painted strainer jug (Figure 75)**

Only one vessel belonging to this shape was recovered from all the assemblages. This vessel is quite common in funerary contexts throughout the Punic period, and is rarely encountered in domestic or ritual contexts. Within funerary contexts, the strainer jug is usually associated with infant burials, hence their interpretation as 'baby-feeders' (Maraoui Telmini 2009: 315-316, fig. 321; Anastasi 2010: 129, Table 7). The single example from Bulebel is relatively well-preserved, where the entire top part of the body, neck and spout are intact. A perforated wall separates the neck and body, and no handle was attached to any part of the top half of the body, suggesting that this vessel in particular did not contain a side strap handle like the types identified by Sagona in the tomb contexts (such as Sagona spouted flasks forms V: 1a-b and VI: 1a-b), nor the strainer-like perforated wall (Sagona 2002: 151-152). Sagona's spouted flask form IV: 1, dated to 300-100 BC, did contain the strainer wall, but also has a handle (Sagona 2002, fig. 290.5, 9). The fabric (Local Fabric 2) and the context suggest that this newly recorded form could be dated from the first century onwards. No other form like this is known on the island.

D56.1. BLB12/32/45: Rim, body and spout, d. 9.2. Local Fabric 2: Fine orange clay with fine lime, foraminifera and fine black glauconite inclusions; evenly applied, yet matt, pale yellow cream slip on exterior surface with thick red-painted bands on the body and rim. Context: Bulebel SU 32, Phase 2.

**D57. 'Baggy-mouthed' jug (Figure 75)**

This vessel is generally characterised as a large flagon or jug with a wide neck, a collared (D57.1-2) or grooved (D57.3-4) rim that is slightly pinched to act as a spout. The neck is attached to a wide body on a flat base. A thick, round-sectioned strap handle is attached from the rim to the shoulder. The form is similar to Sagona's jug form VI: 1c, which she dated to after the mid-first century. Sagona identified a few vessels of this type within late tomb contexts, where one vessel was used as a receptacle for cremated human remains, whilst at least thirteen were recorded from the 1922 excavations at the Roman domus (Sagona 2002: 134, fig. 334: 54-66).



This form was found in contexts dating to between the first and mid-fourth century, making it difficult to date more precisely. However, as with other types of coarse ware jugs, the form was not likely to change much over time. At least one similar example of this form was identified in the 1972 excavations at the Žejtun villa (Anastasi 2010, fig. 132.7). A significant number of similar vessels was recovered from the Melita cistern (SU 1044), supporting a function associated with drawing water. The pottery from the cistern contexts at Melita was not included in this study.

D57.1. BLB12/58/41: Rim, handle and neck, d. 18. Local Fabric 2: Hard pale red/orange fabric with fine yellow and white foraminifera and lots of fine black glauconite inclusions; even pale yellow slip/salt-skin on exterior surface. Context: Bulebel SU 58, Phase 1.

D57.2. BLB12/32/9: Rim, d. 12. Local Fabric 1: Fine orange clay with fine yellow foraminifera and lime inclusions; thin cream exterior skin. Context: Bulebel SU 32, Phase 2.

D57.3. BLB12/32/8: Rim and handle, d. 13. Local Fabric 2: Hard pale red fabric with lots of yellow lime halos, fine foraminifera and fine black glauconite inclusions; thin cream exterior salt skin. Context: Bulebel SU 32, Phase 2.

D57.4. BLB12/58/37a: Rim and handle, d. 11. Local Fabric 2: Hard orange fabric with fine yellow lime, fine white foraminifera, occasional large red iron ore and fine black glauconite inclusions; unslipped pale surfaces. Context: Bulebel SU 58, Phase 1.

#### D58. Coarse ware jug type 5 (Figure 76)

The exact nature of this form is unknown as only rim fragments have been identified so far. The cupped rim is characteristic of a similar vessel catalogued by Sagona (urn form V: 2b), which she dates to 100 BC – AD 50 (Sagona 2002: 133, fig. 348.12). The complete examples identified by Sagona have a wide round mouth, swollen body and wide, flat base, very similar in fact, to type D57 above. No new information regarding the dating of this form was forthcoming from the assemblages.

D58.1. BLB12/24/12: Rim, d. 16. Local Fabric 2: Hard orange fabric with lots of yellow lime halos, white foraminifera and fine black glauconite inclusions; thin cream salt skin on exterior surface. Context: Bulebel SU 24, Phase 2.

D58.2. MLT84/49826: Rim, d. 20. Local Fabric 3: Hard pale orange fabric with white lime, red grains, foraminifera, occasional fine glauconite and gypsum/quartz inclusions; thin cream salt skin on exterior. Context: Melita SU 1086, Phase 3.

D58.3. MLT84/49590: Rim, d. 20. Local Fabric 1: Hard pale grey-brown fabric with a thin pale red core, with fine white lime inclusions; unslipped pale brown exterior surface. Context: Melita SU 1109, Phase 5.

#### D59. Coarse ware jug type 6 (Figure 76)

Only a single example of this flagon rim was identified from the assemblages studied. The surviving rim fragment is triangular and contains two shallow grooves beneath the top of the rim, and is most probably a variant of form D57. Too little information is currently available to suggest a date for this form, but the similarity of shape and fabric to form D57 suggests a date after the first century AD.

D59.1. BLB12/24/11: Rim, d. 12. Local Fabric 2: Hard red fabric with pale yellow lime and foraminifera and abundant very fine black glauconite inclusions; unslipped pale surfaces. Context: Bulebel SU 24, Phase 2.

#### D60. Coarse ware jug type 7 (Sagona jug form V: 2c) (Figure 76)

This form is loosely characterised by a round-mouth vessel with a thickened, triangular rim. The majority of rims of this type came from Foreman Street, Gozo. Complete examples are known from a tomb in Wied il-Ghasri (Gozo), which are the best parallels available and provide a *terminus ante quem* of the first century AD on the basis of an Imperial coin (Sagona 2000: 133, 1126, fig. 251.1-6). No complete profiles were recovered from any of the sites studied, but whole vessels currently on display at the National Museum of Archaeology in Rabat, Gozo, exhibit a wide round mouth, piriform body with a wide, flat base. A thick oval-shaped strap handle is attached from the neck to the shoulder (Figure 77). The presence of the jug at Foreman Street suggests that they were produced there, giving a mid-second/mid-third-century AD. The inclusion of one example (D60.1) from a first-century-AD context at Bulebel is due to the similarity in general shape, whilst the example from Melita (D60.7) is presented here as another possible example of the form, but since it originated from a mixed context, no further comments can be made. This last example can be compared to Sagona's jug form VI: 3c, which she dated to the mid-first century AD, although the example she cites lacks details other than its discovery location at the Roman domus (Sagona 2002: 136, fig. 316.4).

D60.1. BLB12/58/53: Rim, d. 16. Local Fabric 1: Soft pale orange fabric with fine white lime, foraminifera and large dark orange/brown-coloured grog inclusions; smoothed, unslipped surface. Context: Bulebel SU 58, Phase 1.

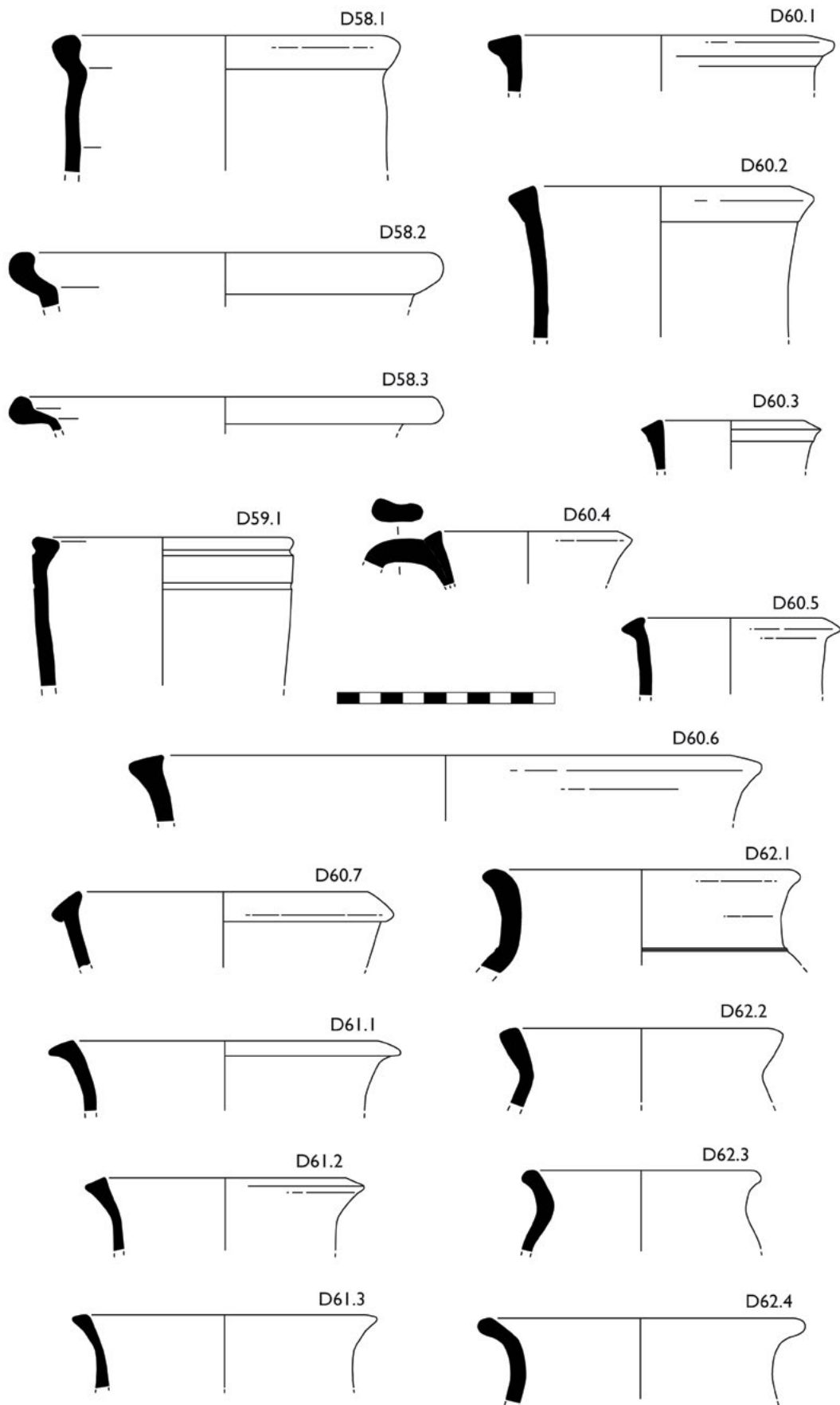

Figure 76: Coarse ware jug and jar forms (D58-D62).



Figure 77: Complete examples of jars (types D60 and D61) and a warped bowl possibly belonging to type D11, on exhibit at the National Museum of Archaeology, Gozo.

D60.2. FRM08/42/62: Rim, d. 14. Local Fabric 2: Hard-fired dark grey clay with white and orange (burnt) lime and foraminifera, and fine black glauconite inclusions; pale grey-white skin; over-fired. Context: Foreman Street SU 42.

D60.3. FRM08/42/61: Rim, d. 6.4. Local Fabric 2: Hard pale orange fabric with yellow lime, white foraminifera and fine black glauconite inclusions; cream salt-slipped exterior surfaces. Context: Foreman Street SU 42.

D60.4. FRM08/42/79: Rim and handle, d. 8. Local Fabric 2: Hard orange/brown fabric with fine yellow lime, white foraminifera and occasional black glauconite inclusions; dark grey skin (over-fired?) with a thumb-impress strap handle attached beneath the rim and presumably to the shoulder. Context: Foreman Street SU 42.

D60.5. FRM08/42/59: Rim, d. 8. Local Fabric 2: Hard pale red fabric with large yellow lime, white foraminifera and fine black glauconite inclusions; cream slip/skin. Context: Foreman Street SU 42.

D60.6. FRM08/42/67: Rim, d. 26. Local Fabric 2: Hard orange fabric with yellow lime, white foraminifera and black glauconite inclusions; cream skin/slip. Context: Foreman Street SU 42.

D60.7. MLT84/23116: Rim, d. 13. Local Fabric 2: Hard orange fabric with white lime and foraminifera and black glauconite inclusions; unslipped pale surfaces. Context: Melita SU 1025, Phase 6 (mixed context).

#### D61. Coarse ware Jar type 8 (Figure 76)

This jar form is very similar to the previous form (type D60) but the rim is more pointed and slightly more everted. All the examples presented below came from Foreman Street and are thus most probably contemporary with many of the coarse ware forms from the same site. Complete vessels with this rim shape were also found in the Wied il-Għasri tomb, suggesting that D60 and D61 could be contemporary forms (Figure 77).

D61.1. FRM08/42/60: Rim, d. 14. Local Fabric 2: Hard pale red fabric with grey edges, with fine white lime, foraminifera and black and red glauconite inclusions; unslipped pale grey skin. Context: Foreman Street SU 42.

D61.2. FRM08/42/63: Rim, d. 11. Local Fabric 2: Hard pale grey fabric with thin pale pink/red edges, with white lime, foraminifera and black glauconite inclusions; unslipped pale surfaces. Context: Foreman Street SU 42.

D61.3. FRM08/57/5: Rim, d. 14. Local Fabric 2: Hard pale red fabric with white lime, foraminifera and fine black glauconite inclusions; unslipped pale skin. Context: Foreman Street SU 42.

#### D62. Coarse ware jar type 9 (Figure 76)

This generic group is characterised by simple everted rims with a short neck attached to a swollen body. No parallels have been identified but the discovery of wasters belonging to this rim shape (D62.1) at Foreman Street

suggests it was produced there (or within the vicinity) around the late-second to mid-third century AD.

D62.1. FRM08/59/20: Rim, d. 13. Local Fabric 2: Hard pale grey fabric with fine yellow lime, white foraminifera and fine black glauconite inclusions; white skin; over-fired waster. Context: Foreman Street SU 59.

D62.2. FRM08/57/25: Rim, d. 13. Local Fabric 2: Pale orange fabric with white and yellow lime and foraminifera and fine black glauconite inclusions; thin cream skin. Context: Foreman Street SU 47.

D62.3. FRM08/42/86: Rim, d. 11. Local Fabric 2: Coarse brown clay with large pale yellow lime, foraminifera and occasional large black glauconite inclusions; unslipped. Context: Foreman Street SU 42.

D62.4. FRM08/42/64: Rim, d. 15. Local Fabric 2: Hard pale red fabric with fine white lime, foraminifera and fine black glauconite inclusions thin white skin. Context: Foreman Street SU 42.

### D63. 'Round-mouthed' jug (Figure 78)

This small jug is characterised by a round-mouthed cupped rim, with a bulbous, piriform body. No bases were associated with the vessels identified in the sample. The cupped rims can be plain (D63.1 and D63.3) or grooved (D63.2 and D63.4), and a single shallow groove circles the top part of the body. A plain or gouged strap handle is attached from the rim to the widest part of the body.

No vessels, even remotely similar to this type were formally classified by Sagona. Nor can any examples be found in the published material for any other Maltese excavation. A possible exception may be revealed in an old photograph of the pottery finds from a tomb discovered in 1907 in New Street [434], Rabat (Malta), which shows a vessel similar in shape to jug form D63. Unfortunately, the vessel has since been lost and no further details are known (Sagona 2002: 997-999, fig. 156.13).

This vessel type was only found in the Bulebel assemblage, in phases 1 and 2, suggesting that the vessel dates from at least the mid-first to early third century AD. The absence of this form in the Melita contexts does also suggest that the vessel did not continue being produced long after the mid-second-third century AD although analyses of more site assemblages from elsewhere on Malta would be needed to support this. The basic form is very common on North African sites in contexts dating to between the first and second century AD in Carthage (Fulford 1984, type 3.9), Utica, and Sabratha (Dore 1989, types 345-350).

D63.1. BLB12/24/1: Rim, body and handle, d. 9. Local Fabric 2: Hard dark orange fabric with white foraminifera, lime and abundant fine black glauconite inclusions; unslipped smoothed and dry-shaved pale surface. Context: Bulebel SU 24, Phase 2.

D63.2. BLB12/54/1: Rim, body and handle, d. 7. Local Fabric 2: Hard orange fabric with very fine yellow lime and foraminifera and fine black glauconite inclusions; unslipped, dry-shaved and smoothed surfaces. Context: Bulebel SU 54, Phase 1.

D63.3. BLB12/55/12: Rim and handle, d. 7.2. Local Fabric 1: Orange clay with fine white and yellow lime and foraminifera and occasional fine red iron grain inclusions; unslipped, smoothed surfaces. Context: Bulebel SU 55, Phase 1.

D63.4. BLB12/58/30: Rim, d. 12. Local Fabric 2: Orange fabric with thin pale grey core, with fine yellow and white foraminifera, lime and fine black glauconite inclusions; thin cream-slipped surfaces. Context: Bulebel SU 58, Phase 1.

### D64. Coarse ware jar type 11 (Figure 78)

This vessel is characterised by a distinctive, double-beaded collared rim, which is probably a form also produced within the vicinity of Foreman Street because of the glauconite fabric (Local Fabric 2), the distribution of the type, and the presence of wasters. No complete profiles, handles, bodies or bases are associated with this rim form, therefore little more can be extrapolated from the current evidence. Also, no parallels on Gozo or Malta are known, except for a single flagon currently on display at the National Museum of Archaeology in Rabat, Gozo. This vessel is associated with an underwater context off the coast of Xlendi Bay, Gozo, but since several different wrecks dating to several periods are known in the area, it remains difficult to determine whether the vessel is related to the Punic, Roman or Islamic period (Figure 79).<sup>15</sup>

D64.1. FRM08/42/73: Rim, d. 10. Local Fabric 2: Orange fabric with yellow lime and foraminifera and fine black glauconite inclusions; evenly applied thick cream slipped surfaces; black inclusions remain visible under slip. Context: Foreman Street SU 42.

D64.2. FRM08/42/72: Rim, d. 9. Local Fabric 2: Pale yellow/red clay with pale grey edges (over-fired?) with yellow lime and foraminifera and black and red (burnt?) glauconite inclusions; thin pale slip/skin. Context: Foreman Street SU 42.

<sup>15</sup> The vessel is on display at the National Museum of Archaeology, Rabat, Gozo. No information about the fabric is available.

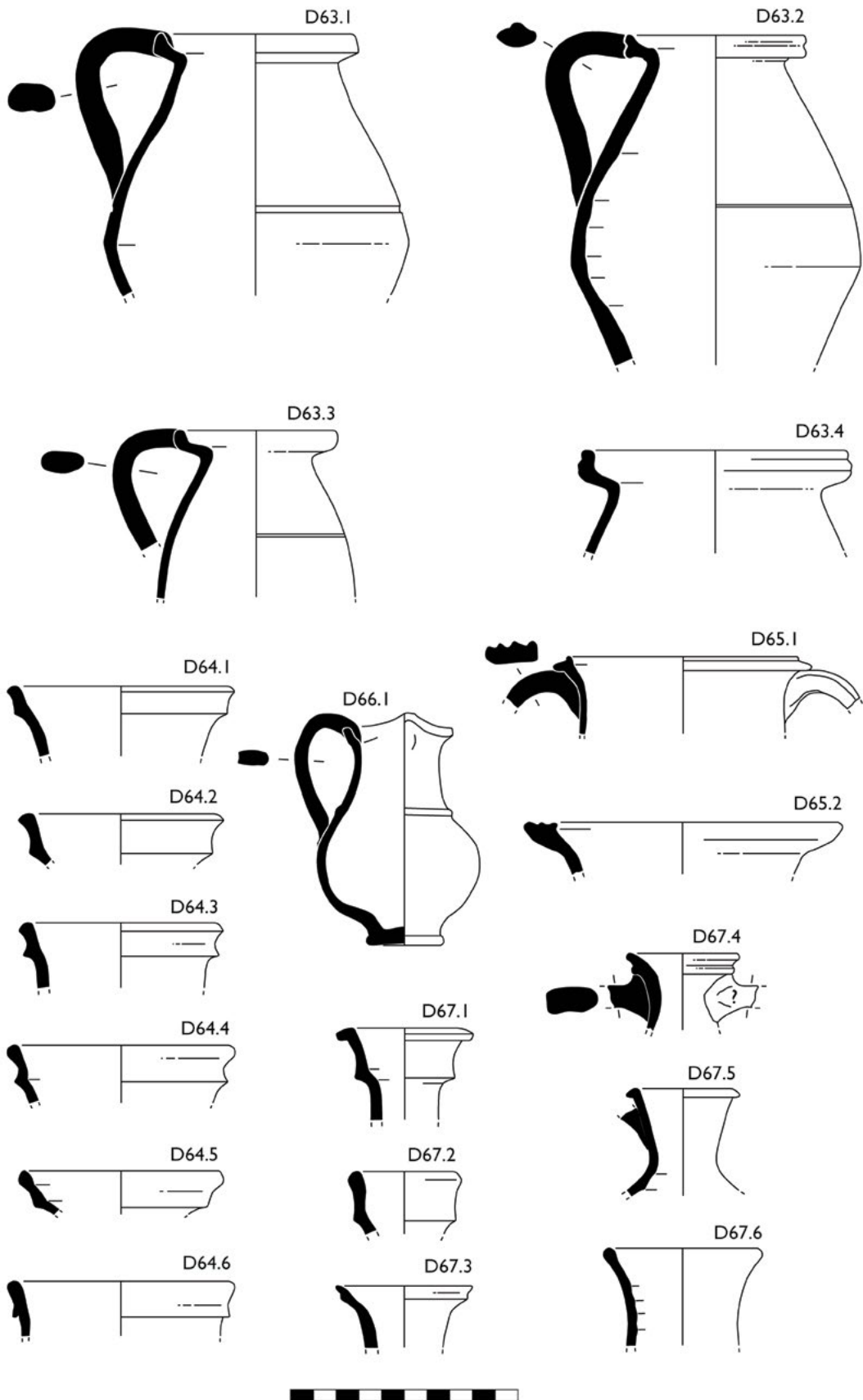

Figure 78: Coarse ware jug and flask forms (D63-D67).

D64.3. FRM08/42/71: Rim, d. 9. Local Fabric 2: Orange fabric with yellow and white lime and foraminifera and fine black glauconite inclusions; thin pale skin. Context: Foreman Street SU 42.

D64.4. FRM08/42/74: Rim, d. 10. Local Fabric 2: Hard red/orange fabric with fine white lime, foraminifera and occasional black glauconite inclusions; unslipped pale skin. Context: Foreman Street SU 42.

D64.5. FRM08/57/18: Rim: Rim, d. 9. Local Fabric 2: Hard pale red/orange clay with white foraminifera, lime and black glauconite inclusions; pale grey skin. Context: Foreman Street SU 57.

D64.6. FRM08/42/70: Rim, d. 10. Local Fabric 2: Hard pale red clay with fine white foraminifera, white lime and black and red glauconite inclusions; dark grey skin, over-fired? Context: Foreman Street SU 42.

### D65. Coarse ware jar type 12 ('Double-handled urns') (Figure 78)

This form is represented by a Hellenistic-inspired domestic amphora with a curved profile, ridged rim and two ribbed strap handles attached to the rim and shoulder. A range of forms was catalogued by Sagona from funerary contexts dating to after the mid-first century AD. These include her urn form VI: 2b (D65.1) and VI: 3b (D65.2). The last type is also characterised by a series of freehand red and black painted decoration over the body (Sagona 2002: 113-114, fig. 349.2-6). A red-slipped version of Sagona's urn form VI: 2a has already been included in the local red-slipped ware section (type B22). Other than the examples from the tomb contexts, no other vessels of this type have been published.

A handful of rims similar to D65.2 was identified in the 1972 material from the Żejtun villa in an area associated with activities dating to after the first century AD (Anastasi 2010, fig. 131.9-11). The majority of sherds associated with these forms comes from the Melita excavation, and includes a number of painted wall fragments, most probably belonging to jars similar to Sagona's urn form VI: 3b. A handful came from a Phase 2 context, whilst a greater proportion of the fragments came from Phase 5 contexts. Two highly fragmented, but complete, vessels came from Tombs 1 (BLB12/75/2) and 3 (BLB12/11/1) from Bulebel, whilst a handful of fragments was also found within the latest quarry levelling, providing further evidence for a post-first century AD date with definite use from the early-to-mid-third century AD. The earliest Melita context that contains fragments of these vessels belongs to Phase 2 and has been dated to the early second century AD. Sagona suggested a mid-third century AD date for these vessels, which is supported by the new

evidence, however Sagona based her dating primarily on similarities with vessels from the Athenian Agora (Sagona 2002: 113-114).

D65.1. BLB12/40/2: Rim and handle, d. 10. Local Fabric 2: Hard dark brown fabric with white and grey foraminifera and black glauconite inclusions; pale grey/brown unslipped skin. Context: Bulebel SU 40, Phase 2.

D65.2. MLT84/49699: Rim, d. 14. Local Fabric 2: Pale brown fabric with fine white lime and foraminifera, red grains, fine black glauconite and grey inclusions; unslipped smooth pale brown surfaces. Context: Melita SU 1104, Phase 2.

### D66. Sagona juglet form VI: 1c (Figure 78)

Only one complete example of this trefoil-mouthed juglet was found within tomb 3 from Bulebel (Figure 80). A handful of similar juglets come from funerary 'Romano-Punic' contexts dated to Sagona's Phase VI (AD 50 onwards) (Sagona 2002: 141-142, fig. 349.21). The Bulebel example is associated with an ARS Hayes 31 (B40.4) dish and other local red-slipped vessels, which can be confidently dated to the early-to-mid-third century AD. No fragments associated with this form came from earlier-dated contexts.

D66.1. BLB12/71/5: Profile, d. 3.4 (base). Local Fabric 1: Hard-fired dark grey fabric with abundant white lime, foraminifera and red iron ore inclusions; flat, string-cut base; over-fired (?) pale grey surfaces. Context: Bulebel SU 71, tomb 3.

### D67. Miscellaneous flasks (Figures 78 and 81)

This category includes a series of rims belonging to flask-like vessels or narrow-mouthed jugs. All of the catalogued sherds came from contexts dating to the end of the second-mid-third to mid-fourth century AD. The general shapes identified include cupped rims (D67.1-2) similar to Sagona's flask form V: 1a-b; thin, flared grooved rims (D67.3-4); simple everted (D67.5-6); ribbed (D67.10) and an imported north Tunisian example (D67.8). Flasks and small jugs such as the ones within this category are interesting because these types of vessels are the least likely range of vessels that retain standardised shapes and types. Changes in rim profiles, handles and decoration are very common throughout the Roman world, making it a difficult and laborious task to create a detailed and useful chronological typology. The widely localised, yet highly variable forms, shapes and sizes may point towards a wide range of 'brands' of locally produced sauces and oils. The occasional imported condiment is also apparent by the presence of a North Tunisian vessel.



Figure 79: Round-mouth jar (D64) from an underwater context off the coast of Xlendi Bay, Gozo.



Figure 80: Coarse ware juglet (D66.1) from Bulebel tomb 3.

D67.1. BLB12/32/38: Rim, d. 6. Local Fabric 1? Orange fabric with fine white foraminifera and lime, crushed gypsum and occasional black glauconite inclusions; unslipped, smoothed surfaces. Type: Sagona flask form V: 1a (Sagona dates this form to her Phase V: 100 BC-AD 50). Context: Bulebel SU 32, Phase 2.

D67.2. FRM08/42/69: Rim, d. 5. Local Fabric 2: Orange fabric with white foraminifera, lime, fine black glauconite and angular red ore inclusions; unslipped surfaces. Type: Sagona flask form V: 1a? Or narrower version of **D64**? Context: Foreman Street SU 42.

D67.3. FRM08/42/75: Rim, d. 6. Local Fabric 2: Pale orange fabric with pale yellow lime, foraminifera and fine black glauconite inclusions; unslipped; trefoil-mouthed or pinched to form spout. Context: Foreman Street SU 42.

D67.4. MLT84/49345: Rim and handle, d. 5. Local Fabric 2: Pale red fabric with fine white lime, foraminifera and fine black glauconite inclusions; thick cream slip on exterior surface; cut strap handle; possibly one or two handled? Context: Melita SU 1093, Phase 4.

D67.5. BLB12/32/26: Rim and handle stump, d. 5. Local Fabric 2: Orange fabric with fine yellow lime and foraminifera, red ore and fine black glauconite inclusions; thin cream exterior skin. Context: Bulebel SU 32, Phase 2.

D67.6. FRM08/42/65: Rim, d. 7. Local Fabric 2: Hard red/orange fabric with fine yellow lime, foraminifera and fine black glauconite inclusions; unslipped pale surfaces. Context: Foreman Street SU 42.

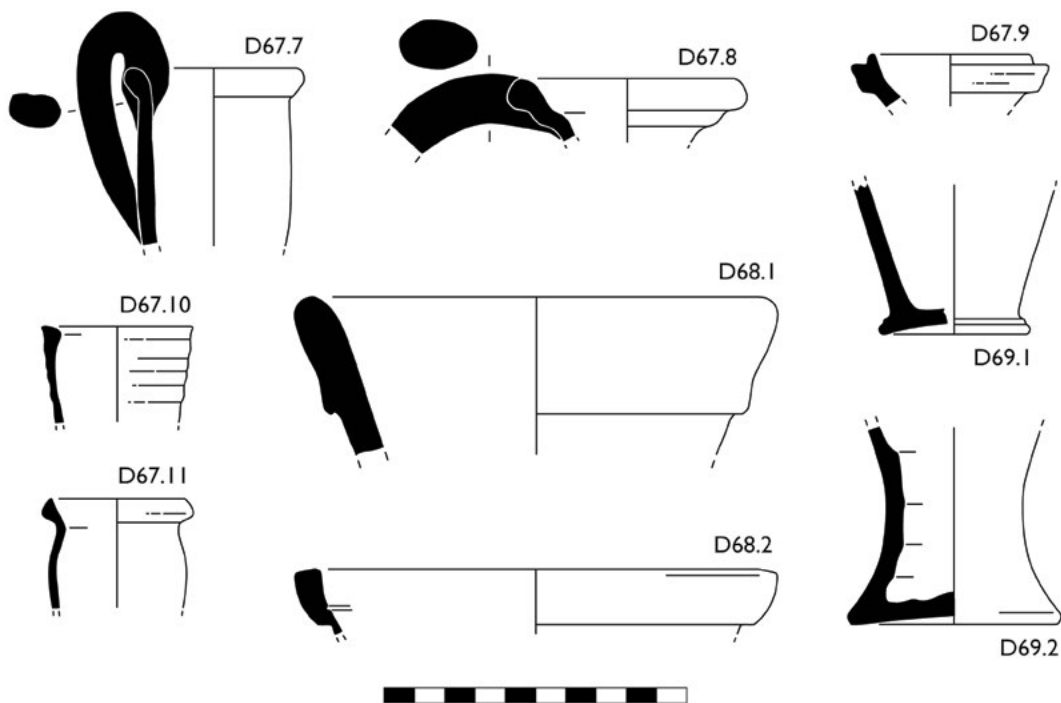

Figure 81: Miscellaneous coarse ware jug and flask forms (D67-D69).

D67.7. FRM08/42/77: Rim and handle, d. 4. Local Fabric 2: pale red/orange clay with fine white/yellow foraminifera and black and red glauconite inclusions; unslipped pale grey surface; oval-section, up-swung handle attached to the rim and bottom of the neck. Context: Foreman Street SU 42.

D67.8. FRM08/42/80: Rim and handle, d. 6. Fabric (Peacock fabric type 2.2): Hard red fabric with abundant fine quartz and occasional fine yellow lime inclusions; cream exterior skin; thick oval section strap handle attached to rim. Imported from North Tunisia; similar to Fulford form 65 from a first-century-BC context (Fulford 1994: 72-73, fig. 4.13 no. 65). Context: Foreman Street SU 42.

D67.9. FRM08/59/19: Rim, d. 5. Local Fabric 2: Pale orange/brown fabric with fine white lime, foraminifera, red ore and fine black glauconite inclusions; unslipped smoothed surfaces. Context: Foreman Street SU 59.

D67.10. MLT84/49717: Rim, d. 5. Local Fabric 1: Pale orange to grey fabric with fine white lime and foraminifera inclusions; unslipped pale brown exterior surface; ribbed neck; no sign of a possible spout, therefore round-mouthed opening. Context: Melita SU 1101, Phase 5.

D67.11. MLT84/49954: Rim, d. 5. Local Fabric 1: Hard pale grey fabric with fine white lime and foraminifera

inclusions; unslipped pale brown exterior surface possibly spouted. Context: Melita SU 1098, Phase 5.

**D68. Miscellaneous collar-rimmed jars (Figure 81)**

D68.1. MLT84/49340: Rim, d. 16. Local Fabric 7: Pink to grey fabric with large white lime and abundant large lacunae due to organic tempering; unslipped. Context: Melita SU 1093, Phase 5.

D68.2. FRM08/42/68: Rim, d. 16. Local Fabric 2: Hard pale red fabric with fine yellow lime, foraminifera, fine red ore and fine black glauconite inclusions; unslipped. Context: Foreman Street SU 42.

**D69. Miscellaneous jar/jug bases (Figure 81)**

D69.1. MLT84/49859: Base, d. 5. Fabric: Hard orange fabric with round quartz, red ore and lime inclusions; smooth flat base; cream-slipped exterior surfaces; North African import? Context: Melita SU 1085, Phase 3.

D69.2. MLT84/49823: Base, d. 7. Local Fabric 1: Hard pale red fabric with fine white lime and foraminifera inclusions; smoothed cream exterior surfaces; slightly convex base. Context: Melita SU 1086, Phase 3.

*Large storage containers (D70-D74)*

This class includes a range of storage vessels common on most Maltese Classical-period sites.



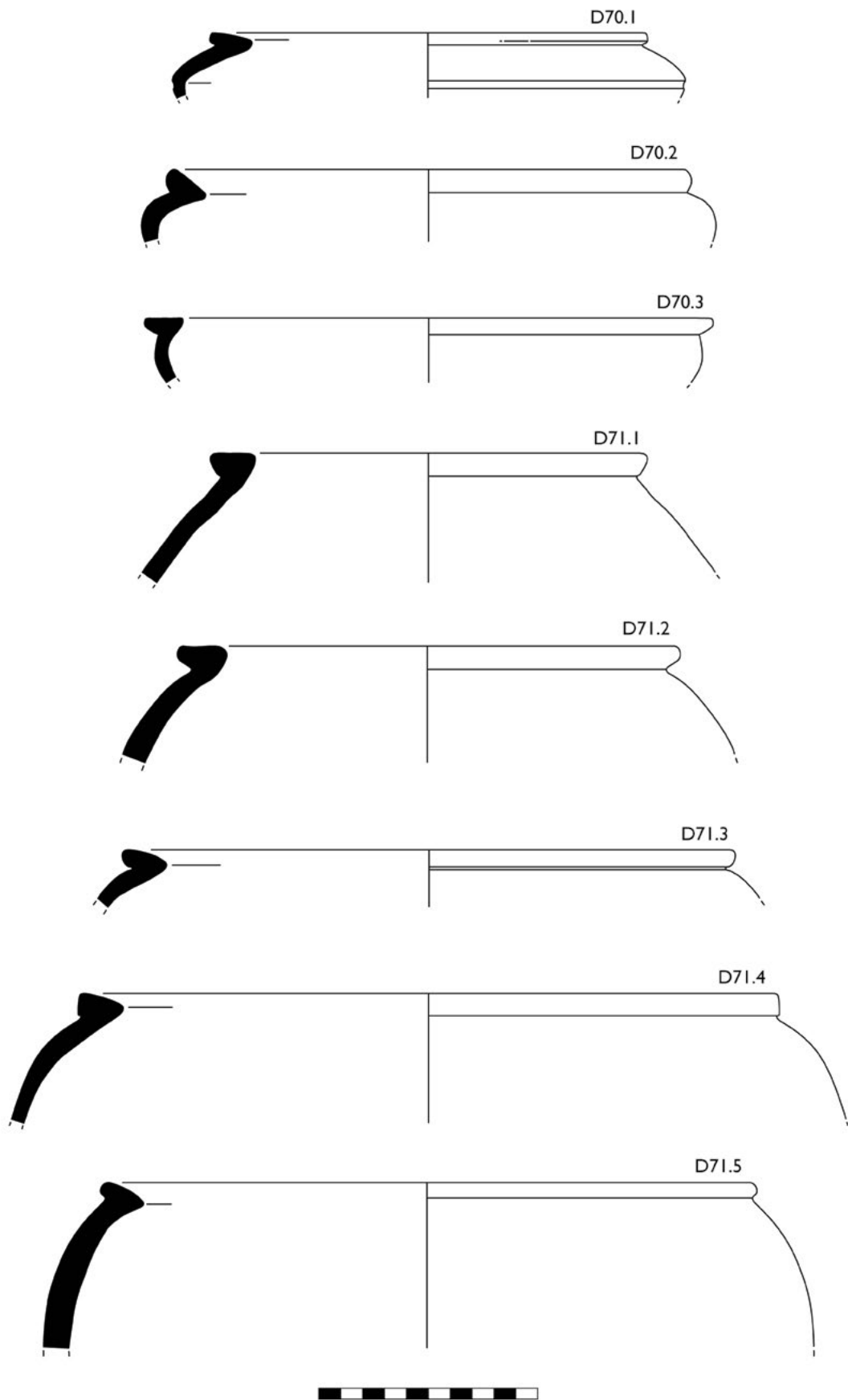

Figure 82: Coarse ware storage jar forms (D70-D71).

**D70. Coarse ware storage jar type 1 (Figure 82)**

This closed vessel is characterised by a flat or inverted bevelled rim with a high carinated shoulder. This vessel appears to share traits with the common cinerary urn (see type **D71**), although the wider opening and the distinct shoulder make the vessel's body much squatter. No complete profiles were recovered making it impossible to determine how deep the vessel shape actually was. In addition, no similar forms were recorded amongst any of the funerary material, although a handful of vessels similar to this shape come from the sanctuary of Tas-Silġ (Sagona 2015, fig. 1.37:5). This type is associated with post first-century-AD contexts.

D70.1. BLB12/23/5: Rim, d. 20. Local Fabric 3: Hard red fabric with thin dark grey edges with fine white lime, foraminifera, fine crushed translucent gypsum and occasional fine shiny glauconite inclusions; shallow groove near carination; thin pale brown skin. Context: Bulebel SU 23, Phase 2.

D70.2. BLB12/58/15: Rim, d. 24. Local Fabric 1: Pale red fabric with fine yellow and white lime and foraminifera inclusions; unslipped grey exterior surfaces. Context: Bulebel SU 58, Phase 1.

D70.3. BLB12/58/25: Rim, d. 26. Local Fabric 1: Pale orange fabric with fine white and yellow lime and foraminifera and fine red ore or grog inclusions; unslipped. Context: Bulebel SU 58, Phase 1.

**D71. Coarse ware storage jar type 2 ('Cinerary urn') (Figure 82)**

This category represents rims that belong to a range of wide-mouthed closed vessels similar to the local Maltese cinerary urns, commonly associated with funerary contexts (Sagona 2002: 105-108, fig. 346.2-7). The majority of rims are stylistically similar to Sagona's urn form IV: 1, but since no complete profiles were found that reveal more of the body and base of this form, this comparison is tentative. Similar large vessels with no handles and a more bulbous, less curved, body have been recorded from the recent University of Malta excavations at Tas-Silġ (Sagona 2015, fig. figs 1.35-37) and Ħal Millieri (Blagg, Bonanno and Luttrell 1990: 59, fig. 14.36). Since this form is not associated with tomb contexts, it probably acted as a domestic container for the storage of foodstuffs. Few handles are associated with the Tas-Silġ examples, also suggesting a further deviation from the purely funerary type. Interestingly, this form is mostly associated with the post-first century AD contexts in the assemblage sample. In addition, none of the urn-like vessels are associated with any of the four tomb contexts in this sample, suggesting that cinerary urns use fell out of favour by the mid-third century AD.

D71.1. BLB12/42/1: Rim, d. 20. Local Fabric 1/7: Hard pale red fabric with a thick pale grey core with large yellow lime, fine foraminifera, dark grey and red grog-like inclusions; thin pale grey skin on exterior surfaces. Context: Bulebel SU 42, Phase 2.

D71.2. BLB12/28/3: Rim, d. 23. Local Fabric 7 (**Figure 23**): Coarse pale brown fabric with fine grey foraminifera/lime and larger pale red and grey grog-like inclusions. Unslipped paler skin. Context: Bulebel SU 28, Phase 2.

D71.3. BLB12/28/8: Rim, d. 24. Local Fabric 2: Pale orange fabric with fine yellow lime, fine white foraminifera, fine black glauconite and occasional large pale red grog inclusions; unslipped. Context: Bulebel SU 28, Phase 2.

D71.4. BLB12/32/5: Rim, d. 28. Local Fabric 1 (**Figure 22**): Hard red/orange fabric with large yellow lime and fine white foraminifera; thin pale brown to cream slipped surfaces. Context: Bulebel SU 32, Phase 2.

D71.5. BLB12/32/39: Rim, d. 30. Local Fabric 2: Hard red fabric with thick grey core with medium-to-large yellow lime and foraminifera and sporadic fine black glauconite inclusions; evenly applied thin pale brown slipped surfaces. Context: Bulebel SU 32, Phase 2.

**D72. Coarse ware storage jar type 3 (Figure 83)**

Presumably, this storage vessel was manufactured with a similar purpose in mind to the previous urn-like form (type **D71**). The main difference is seen in the vertical wall.

D72.1. BLB12/57/2: Rim, d. 32. Local Fabric 7? Coarse brown fabric with large pale pink lime or grog, and grey foraminifera inclusions; unslipped grey surfaces. Context: Bulebel SU 57, Phase 1.

**D73. Coarse ware storage jar type 4 (Figure 83)**

This form is morphologically similar to the previous storage vessel with vertical walls (type **D72**), but for a difference with the rim, which is thicker and more angular.

D73.1. BLB12/58/28: Rim, d. 34. Local Fabric 1/7? Coarse pale brown fabric with large yellow lime, foraminifera and pale red, green and grey grog inclusions; unslipped pale skin. Context: Bulebel SU 58, Phase 1.

D73.2. MLT84/24740: Rim, d. 27. Local Fabric 1: Coarse orange fabric with large lime and foraminifera inclusions; blackened exterior, probably use-wear-related? Context: Melita SU 1062, Phase 4.

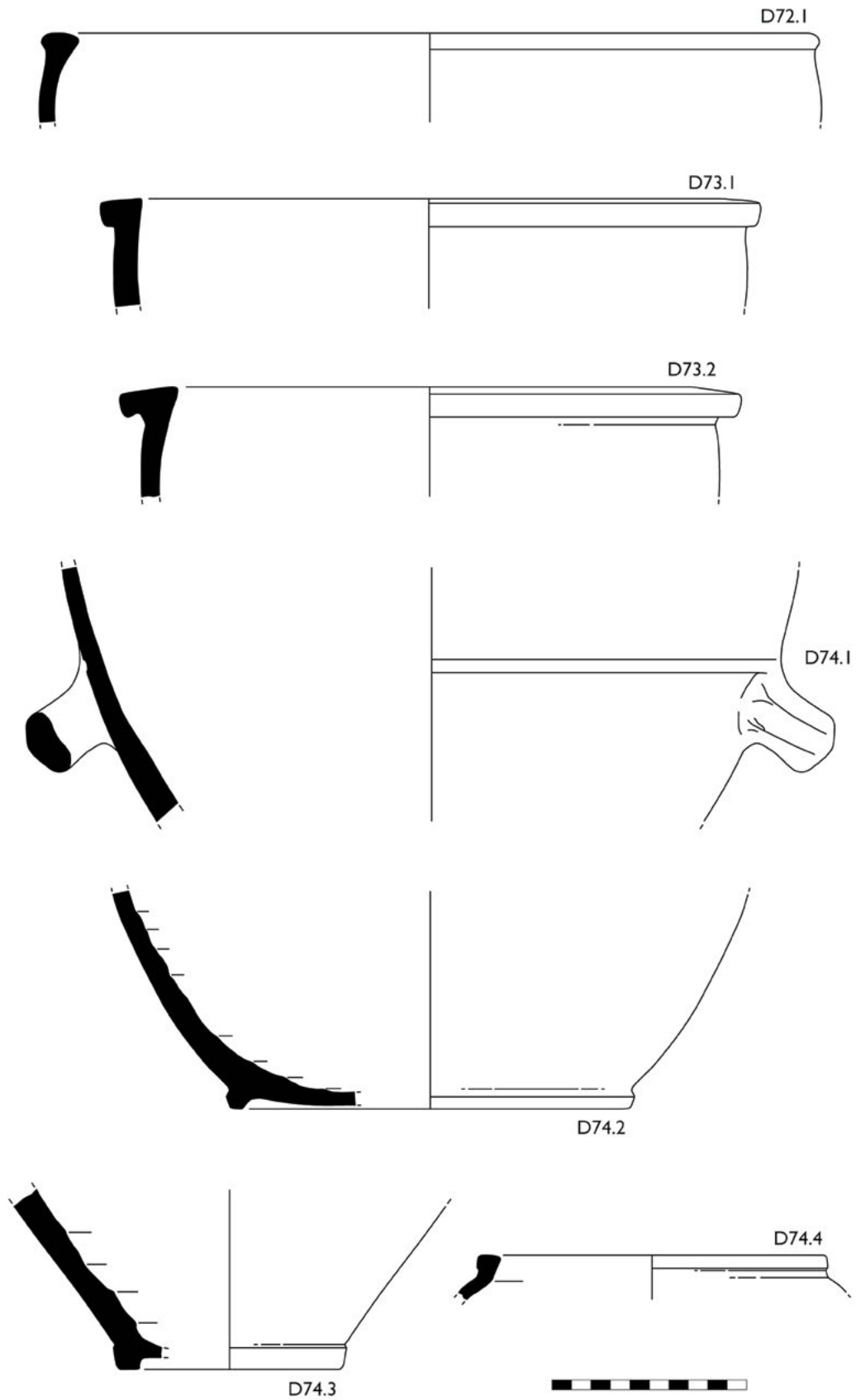

Figure 83: Coarse ware storage jar forms (D72-D74).

**D74. Miscellaneous storage vessels (Figure 83)**

This category includes a range of fragments belonging to large storage vessels that are local to the Maltese islands and are broadly dated to the Roman period.

D74.1. BLB12/32/42: Horizontal strap handle. Local Fabric 2: Hard red fabric with a thin dark grey core, with large pale yellow lime, fine foraminifera, and occasional fine round black glauconite inclusions; slightly ribbed oval-section handle; shallow groove above horizontal handle; thin cream exterior surface. Context: Bulebel SU 32, Phase 2.

D74.2. BLB12/58/48: Ring base, d. 21. Local Fabric 2: Dark orange fabric with fine yellow lime, foraminifera, fine black glauconite and occasional red ore inclusions; burnished pale pink exterior surfaces. Contexts : Bulebel SUs 54, 55 and 58, Phase 1.

D74.3. MLT84/23969: Ring base, d. 12. Fabric: Fine buff-coloured fabric with abundant fine, round quartz and micaceous inclusions; unslipped pale surfaces. Imported; possibly from the north-east Sicilian coast? Context: Melita SU 1044, Phase 1.

D74.4. MLT84/26352: Rim, d. 18. Local Fabric 2: Orange fabric with fine lime, foraminifera and fine black glauconite inclusions; cream exterior surfaces. Context: Melita SU 1100, Phase 2.

*Dolia (D75-D79)*

This category includes large, thick-walled, heavy vessels similar to Roman dolia used for the storage of both dry and liquid foodstuffs. Very little published literature is available for locally produced vessels of this size, but dolia fragments are occasionally found on some Classical-period sites.

**D75. Dolium type 1 (Figure 84)**

This large, thick-walled storage vessel is certainly not common on Maltese sites, and indeed only a single example was identified within the assemblages studied. This form is characterised by a vertical, beaded rim with a slightly indented interior. No wall or base sherds were found associated with this rim, therefore little is known about the exact size of the vessel. The vessel is made using Local Fabric 1. No parallels are known from other Maltese sites but similar-shaped rims are known from Berenice (Riley 1979, fig. 118, no. 751) and elsewhere, although the publishing of dolia fragments remains uncommon. The presence of this form in the Bulebel assemblage suggests a date sometime after the first century AD, although more examples from secure contexts are needed to confirm this chronology.

D75.1. BLB12/23/1: Rim, d. 39. Local Fabric 1: Coarse and gritty pale hard pale red and yellow clay with thick pale grey core; with large yellow lime, pale grey grog and finer white foraminifera inclusions; rough, matt, thin pale yellow slip on surfaces. Context: Bulebel SU 23, Phase 2.

**D76. Dolium type 2 (Figure 84)**

This dolium rim form is more common than the previous type and is characterised by a folded, flat-topped triangular rim. Unlike type **D75**, this form has no distinct neck and the body swells into a large globular form. The widest opening recorded is about 40 cm in diameter (e.g. **D76.3**), whilst the inclination of the body suggests that a complete example would be rather large. Dolia with similar rim shapes have been recorded at the Żejtun villa (Anastasi 2010: 138), San Pawl Milqi villa (Rossignani 1965: 144, 149 and 154) and the Malta Survey Project in Bidnija (find no. MSP2008/1/B21/W1/3), and presumably more have been found over the centuries but none have been recorded and published. The examples were recovered from the Bulebel and Melita assemblages and were associated with contexts dating to the early to mid-first century AD (Bulebel, Phase 1) to the mid-fourth century AD (Melita, Phases 3-5). All the examples were made in Local Fabric 1. This together with the lack of examples from any Gozitan context could suggest a primarily Maltese-based production for these vessels, but the study of more Gozitan assemblages is required to clarify this.

D76.1. BLB12/32/31: Rim, d. 36. Local Fabric 1 (**Figure 22**): Hard, coarse orange/red clay with distinct dark grey core with large yellow lime, fine grey grog and foraminifera; some round red ore grains; pale yellow/pink even matt slip on surfaces. Context: Bulebel SU 32, Phase 2.

D76.2. BLB12/14/1: Rim, d. 40. Local Fabric 1 (**Figure 22**): Hard-fired coarse red fabric merging into dark grey clay with lots of large and medium-sized yellow lime inclusions, foraminifera and translucent white gypsum; unslipped, smoothed pale grey skin. Context: Bulebel SU 14, quarry 2.

D76.3. BLB12/32/2: Rim, d. 55. Local Fabric 1: Hard-fired coarse orange clay with medium-sized yellow lime and fine white foraminifera inclusions; unslipped, pale skin on surfaces. Context: Bulebel SU 32, Phase 2.

**D77. Dolium type 3 (Figure 84)**

A single example of this form was identified in a mid-third-mid-fourth-century-AD context in Melita. The inverted rim is collared and thickens towards a point. No other local or foreign parallels are known.

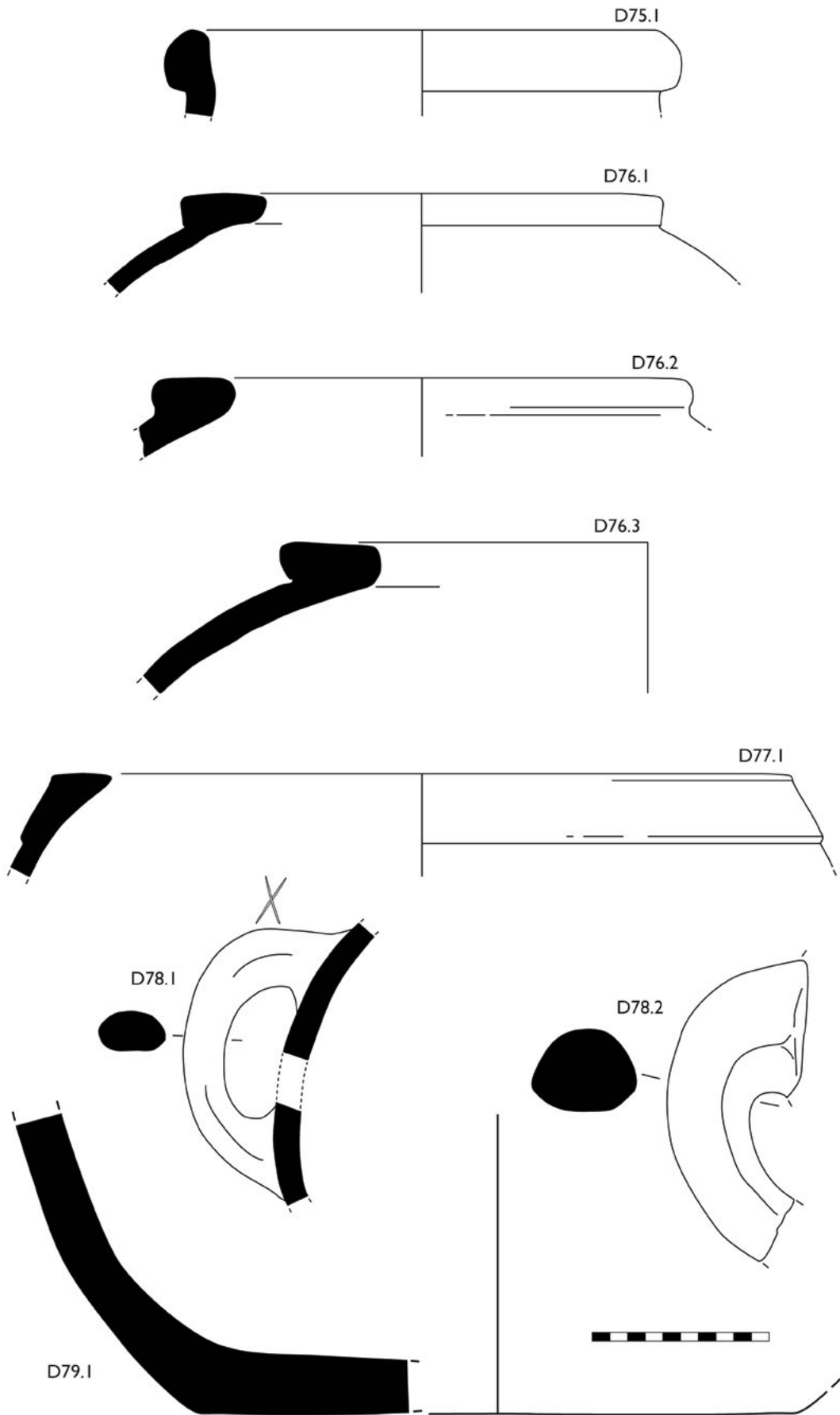

Figure 84: Dolia forms (D75-D79).

D77.1. MLT84/26872: Rim, d. 60. Local Fabric 1: Hard, coarse orange clay with thick pale grey core, with large yellow lime and white foraminifera inclusions; pale yellow-slipped exterior surfaces. Context: Melita SU 1075, Phase 3.

**D78. Dolia handles (Figure 84)**

This category includes examples of large, thick vertical loop handles, which were probably attached to large dolium-like storage containers. Very little can be said about the chronology of these particular examples, except that they came from an early Roman context (Bulebel, Phase 1). One example (D78.1) contained an incised graffito (X) on the top part of the handle, probably related to the type or amount of contents the vessel was intended to carry.

D78.1. BLB12/58/22: Handle. Local Fabric 1: Hard pale red clay with thick pale grey core; contains lots of fine to medium yellow lime inclusions and foraminifera; rough, unslipped pale grey skin;

incised 'X' on top of oval-section handle. Context: Bulebel SU 58, Phase 1.

D78.2. BLB12/58/52: Handle. Local Fabric 1: Hard orange clay with fine and large yellow lime, foraminifera and some red ore inclusions; thick yellow slip; oval-section. Context: Bulebel SU 58, Phase 1.

**D79. Dolium base (Figure 84)**

This thick-walled flat base belongs to a very large storage vessel or dolium. With such a wide, sturdy base, the actual vessel was probably rather heavy, especially when full. The wall thicknesses are similar to the walls attached to many of the rim fragments listed above, so one can easily picture a wide-bodied container, measuring c. 60-70 cm tall and c. 70 cm wide.

D79.1. BLB12/58/51: Base, d. 34. Local Fabric 1: Coarse orange/brown gritty clay with lots of fine to large yellow lime/foraminifera and small red ore inclusions; burnished pale yellow slipped surfaces;

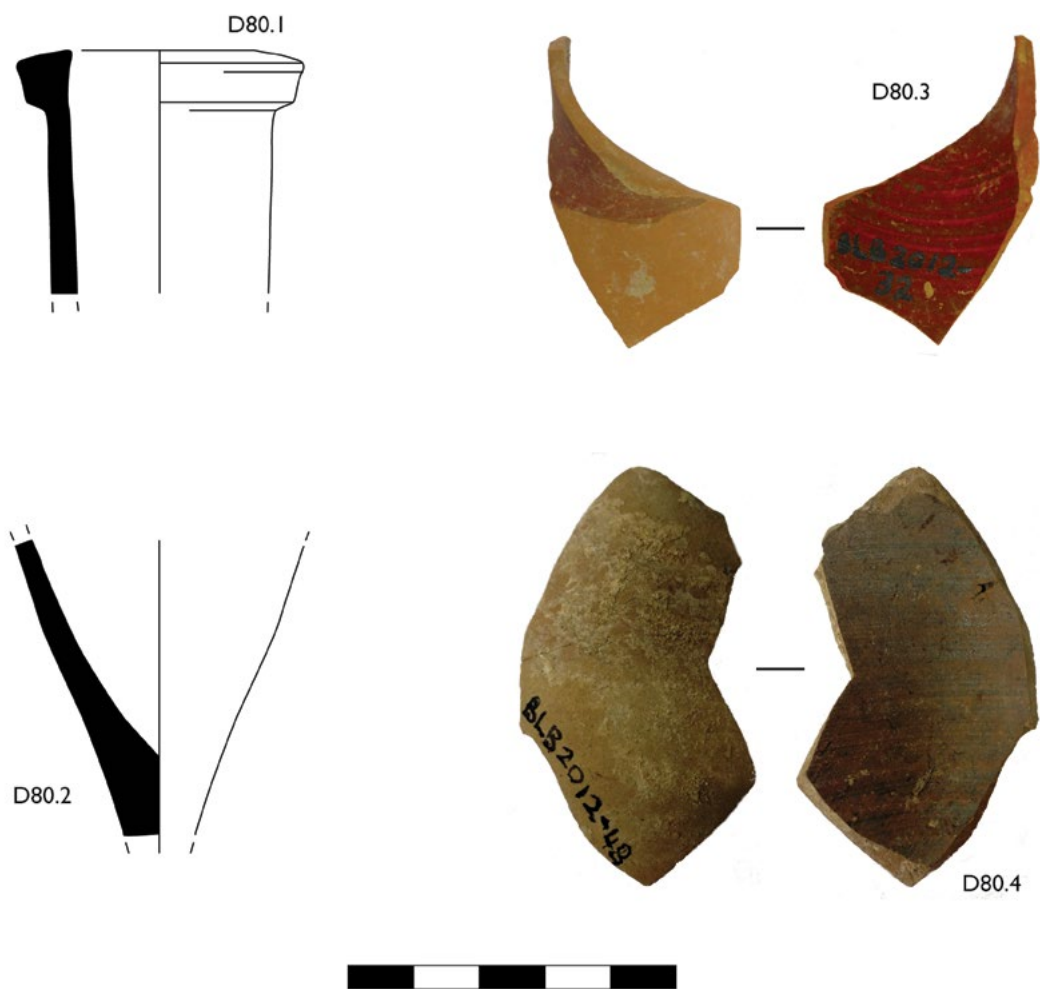

Figure 85: Imported unguentaria (D80).

smoothed flat and burnished base. Context: Bulebel SU 58, Phase 1.

*Unguentaria* (D80)

### D80. Imported unguentaria (Figure 85)

A small number of fragments (n=10) belonging to unguentarium-like containers was recovered from the Bulebel and Melita assemblages. Half these fragments were undiagnostic local sherds, whilst the remaining half were imported, most originating from an eastern source. Example **D80.1** shares parallels with a *lagynos* from Berenice, which is also known from other Late Hellenistic contexts across Tripolitania and Cyrenaica and dated to between the first century BC and end of the first century AD (Riley 1979: 379-380, fig. 136, no. 1107). Not enough information is available for the other shapes or their contexts to comment further.

D80.1. BLB12/28/12: Rim, d. 4.4. Fine pale brown sandy fabric with fine white and black inclusions; smoothed, faceted unslipped surfaces. Source: Imported; Aegean? Type: Riley 1979, no. 1107. Date: first century BC to first century AD. Context: Bulebel SU 23 and 28, Phase 2.

D80.2. BLB12/32/11: Peg. Fine pale orange clay with lots of micaceous inclusions; smoothed slipped surface. Source: Imported; Aegean? Type: Small fusiform type. Date: Hellenistic. Context: Bulebel SU 32, Phase 2.

D80.3. BLB12/32/51: Wall. Fabric: Very fine pale orange fabric with fine white inclusions; smoothed unslipped body with red-painted band on exterior surface and red-painted interior surface. Source: Imported; Aegean? Type: Unknown. Date: Hellenistic? Context: Bulebel SU 32, Phase 2.

D80.4. BLB12/48/4: Wall. Fabric: Fine pale grey clay with no visible inclusions; thin grey/dark red metallic slips coats the interior surface; unslipped, smooth exterior surface. Source: Imported. Type: Unknown. Date: Unknown. Context: Bulebel SU 48.

### Lamps (L1-L2)

A small number of lamps came from across the three assemblages, however, the majority of them came from the tomb contexts at Bulebel. A greater proportion of local lamps were recovered, with one North African lamp fragment<sup>16</sup> and two other unknown imported sherds.<sup>17</sup>

<sup>16</sup> This fragment (FRM08/42/97) is a small North African lamp handle in Peacock fabric 2.1 and comes from SU 42 from Foreman Street (Gozo).

<sup>17</sup> These two wall fragments belong to mould-made closed lamps and are made in fine pale orange to buff clays with fine quartz and lime

### L1. Closed lamp type 1 (Figure 86)

Only one example of this particular form was identified and consists of the body of a warped closed lamp with a ring base. It was not associated with a spout but might belong to a local shape similar to Sagona Lamp form IV: 2 dated from the beginning of the second and end of the first century BC (Sagona 2002: 232, fig. 346.37). Sagona's date does not contradict the context of the find (Bulebel Phase 1), and the complete absence of this shape in later contexts – which incidentally are dominated by a different type (see type **L2**) – supports Sagona's chronology, although more stratified examples would help check this.

L1.1. BLB12/58/31: Body and base, d. 4. Local Fabric 2: Hard pink/yellow clay with fine black glauconite, white foraminifera and yellow lime inclusions; ring base; warped body (waster?). Context: Bulebel SU 58, Phase 1.

### L2. Closed lamp type 2 (Sagona lamp form IV-V: 2) (Figure 86)

This form is the most common type of lamp recorded within this assemblage, and came almost exclusively from the Bulebel tomb assemblages. Complete examples show a closed 'ink well' body, with two or three pierced 'air' holes, with a flat base and pointed spout, modelled on earlier Hellenistic forms. This type can be dated quite confidently to at least the early-mid-third century AD on the basis of the associated tomb furniture at Bulebel.

Each vessel also shows clear traces of use-wear with traces of black soot on the spout. Sagona also recorded this lamp shape in tomb contexts but she dates the form to the end of the second century to early first century BC, but a closer look at the contexts and associated finds does not support the early date she suggests (Sagona 2002: 234).<sup>18</sup> At least one lamp spout, similar to this type was recovered from the 1972 assemblage at the Žejtun villa (Anastasi 2010, figs 32 and 131.3, no. 241), however the difference in the formation of the spout – the latter example exhibiting a better formed, rounded nozzle – might reflect different production lines or, more probably, a chronological evolution.

L2.1. BLB12/84/1: Complete, d. 5.5 (base). Local Fabric 1: Hard-fired pale brown clay with white foraminifera, fine lime, occasional black (stray glauconite) and red

inclusions. Both sherds came from Melita (SUs 1062 and 1081).

<sup>18</sup> The examples that are listed under 'known provenance' are either found in tombs that have pottery that can be dated to late second-early third century AD date (i.e. the painted urn form VI: 3a-b from Ġnien is-Sultan [141]) or the illustration she bases her classification on is unclear (i.e. Sagona 2002, fig. 34.4 also from a tomb at Ġnien is-Sultan [140]).

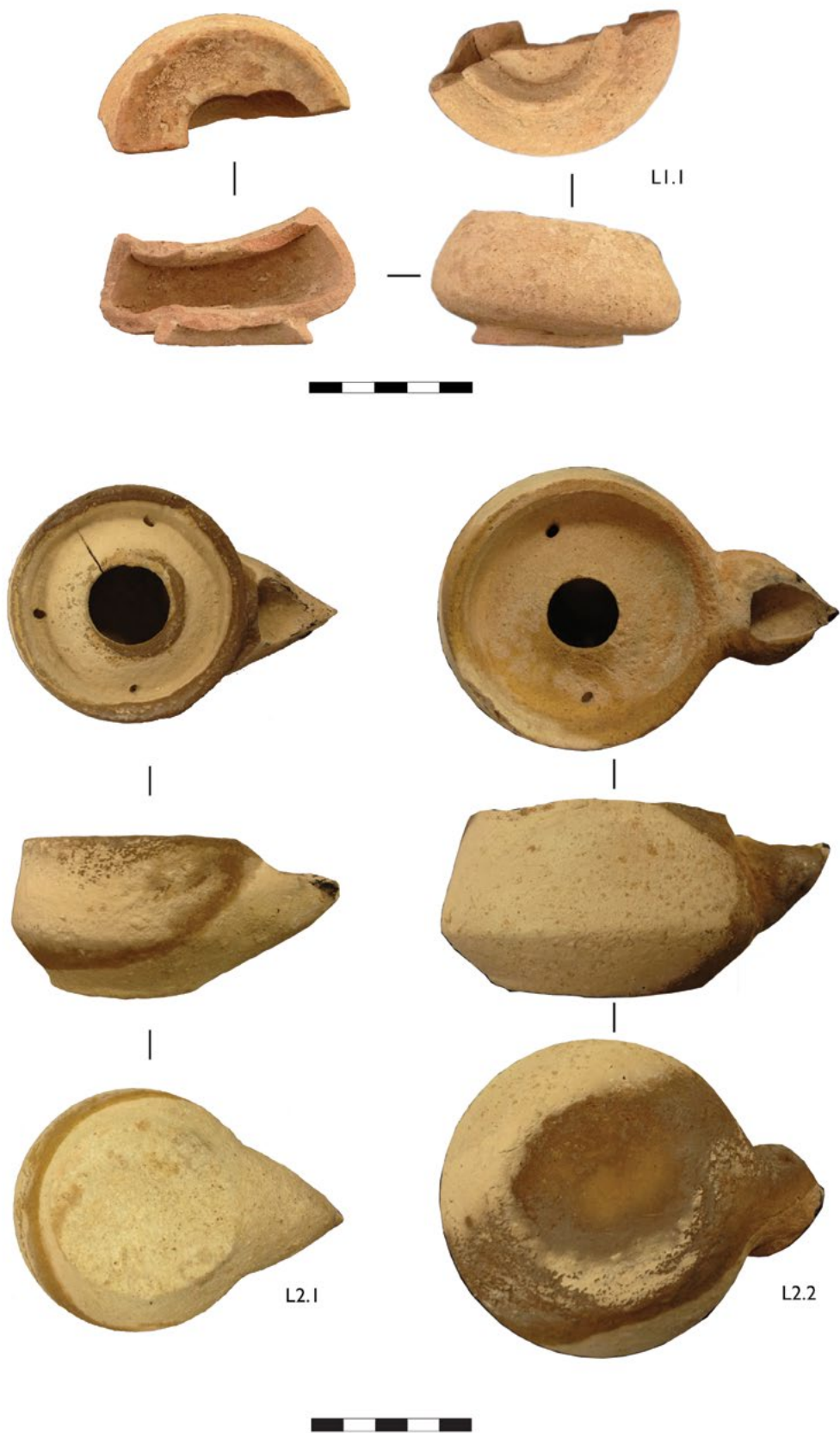

Figure 86: Local closed lamp forms (L1-L2).



grain inclusions; pale brown salt-slipped skin; flat base; partly encrusted surface; black soot use-wear on spout. Context: Bulebel SU 84, tomb 2.

L2.2. BLB12/84/2: Complete, d. 6 (base). Local Fabric 1: Hard-fired pink clay with fine white lime and foraminifera inclusions; unslipped, wet-wiped cream skin; flat base; partly encrusted; black soot use-wear on spout. Context: Bulebel SU 84, tomb 2.

**Miscellaneous vessels (M1-M6)**

This group includes a wide range of various types of vessel forms which are uncommon, unusual or undiagnostic. It is hoped that future research on local ceramic assemblages will shed further light on some of these forms.

**M1. Pot stand type 1 (Figure 87)**

The term for this vessel is purely speculative, but suggests the possibility that this rim might belong to a low pot stand used to support leather-hard pottery vessels whilst drying or being fired in a kiln (see Riley 1979: 353, fig. 128, nos 959-965 for similar examples at Berenice and the references therein). The suggestion is based on the thickened and flattened rim, and its presence within the Foreman Street assemblage, which is associated with pottery production.

M1.1. FRM08/42/66: Rim/base, d. 18. Local Fabric 2: Pale brown clay with fine black glauconite, fine white foraminifera and lime, and round red grain inclusions; unslipped white skin. Context: Foreman Street SU 42.

**M2. Pot stand/base type 2 (Figure 87)**

These two small examples may belong to a similar pot stand or else formed part of a thickened ring-base for a large closed vessel.

M2.1. FRM08/42/90: Rim/base, d. 14. Local Fabric: Hard-fired brown clay with lots of fine black glauconite, and fine white lime and foraminifera inclusions; unslipped grey skin. Context: Foreman Street SU 42.

M2.2. FRM08/42/89: Rim/base, d. 18. Local Fabric 2: Pale yellow/brown clay with fine black glauconite, white foraminifera and yellow lime inclusions; unslipped. Context: Foreman Street SU 42.

**M3. Flat strap handle (Figure 87)**

This category represents a single thick, flattened strap handle of a large vessel, with three V-shaped groups and a deliberately drilled hole through the handle. The fabric is similar to Local Fabric 1 but might also be a western Sicilian fragment based on the surface finish

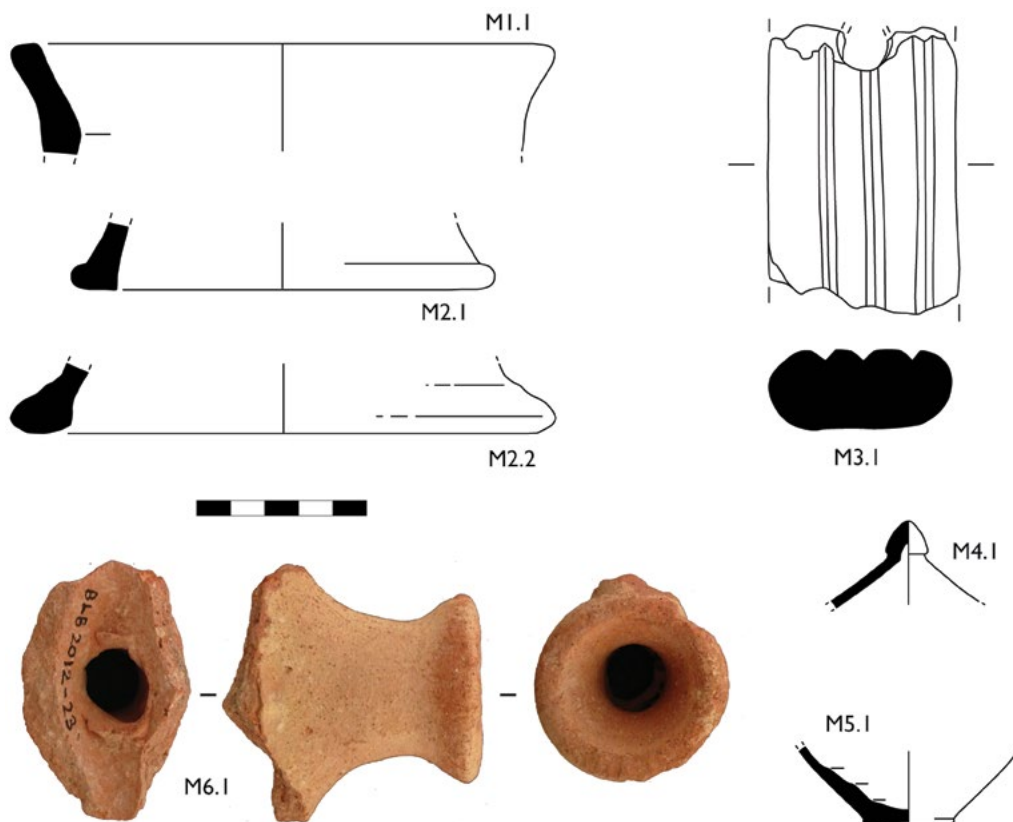

Figure 87: Miscellaneous coarse ware forms (M1-M6).

and on comparison with known Sicilian coarse ware samples.

M3.1. MLT84/25238: Handle. Local Fabric 1? Hard-fired brick-red clay with lots of fine yellow lime, lime halos and foraminifera inclusions; thick pale yellow rough slip/skin. Context: Melita SU 1072, mixed.

#### **M4. Pointed knob (Figure 87)**

This sherd might form part of a lid, possibly similar to a knob from Berenice (Riley 1979, fig. 119 no. 793).

M4.1. FRM08/42/134: Lid knob? Local Fabric 2: Pale yellow/brown clay with fine black and brown glauconite and fine white foraminifera inclusions; unslipped. Context: Foreman Street SU 42.

#### **M5. Imported base (Figure 87)**

This undiagnostic base belongs to a small closed vessel and the fabric and finish points towards a central Mediterranean source, possibly North Africa or western Sicily. No clear parallels have been found.

M5.1. FRM08/42/99: Base, d. 3. Fabric: Hard-fired, compact red/brown clay with fine quartz/gypsum, fine grey shell-like inclusions, white lime and some fine black inclusions; unslipped red surface with dark grey skin on part of body and base akin to black-topped ware surface treatments. Source: North African or western Sicilian? Context: Foreman Street SU 42.

#### **M6. Frying pan handle or spout? (Figure 87)**

This sherd is a distinct hollow hyperboloid attached to a separate wall on one end. This fragment probably belonged to a frying pan handle, but the hollow through the entire length of the vessel suggests that this feature might have actually been a spout for a bottle or large basin of some sort.

M6.1. BLB12/23/7: Handle? Spout? Fabric: Hard-fired granular clay with fine round quartz, black sand, paste voids, white foraminifera and yellow inclusions; pale yellow/pink skin. Context: Bulebel SU 23, Phase 1.

## Appendix 1: Catalogue entry concordance

The following appendix is a concordance between the original catalogue entries (Anastasi 2015) with the simpler ones used in this volume.

Old catalogue entry (Anastasi 2015)	New catalogue entry	Figure
1.1.1-1	A1.1	Figure 24
1.1.1-2	A1.2	Figure 24
1.1.1-3	A1.3	Figure 24
1.1.1-4	A1.4	Figure 24
1.1.1-5	A1.5	Figure 24
1.1.2-1	A2.1	Figure 24
1.1.2-2	A2.2	Figure 24
1.1.2-3	A2.3	Figure 24
1.1.2-4	A2.4	Figure 24
1.1.2-5	A2.5	Figure 24
1.1.2-6	A2.6	Figure 24
1.1.2-7	A2.7	Figure 25
1.1.2-8	A2.8	Figure 25
1.1.3-1	A3.1	Figure 25
1.1.3-2	A3.2	Figure 25
1.1.4-1	A4.1	Figure 25
1.1.4-2	A4.2	Figure 25
1.2.1-1	A5.1	Figure 25
1.2.1-2	A5.2	Figure 25
1.2.2-1	A6.1	Figure 25
1.2.2-2	A6.2	Figure 25
1.2.3-1	A7.1	Figure 25
1.2.4-1	A8.1	Figure 25
1.2.5-1	A9.1	Figure 25
1.2.5-2	A9.2	Figure 26
1.2.5-3	A9.3	Figure 26
1.2.5-4	A9.4	Figure 26
1.2.5-5	A9.5	Figure 26
1.2.5-6	A9.6	Figure 26
1.2.6-1	A10.1	Figure 26
1.2.6-2	A10.2	Figure 26
1.2.6-3	A10.3	Figure 28
1.2.7-1	A11.1	Figure 28
1.2.7-2	A11.2	Figure 29
1.2.7-3	A11.3	Figure 29
1.2.8-1	A12.1	Figure 30
1.2.8-2	A12.2	Figure 30
1.2.8-3	A12.3	Figure 30
1.2.8-4	A12.4	Figure 30
1.2.8-5	A12.5	Figure 30

Old catalogue entry (Anastasi 2015)	New catalogue entry	Figure
1.2.8-6	A12.6	Figure 30
1.2.9-1	A13.1	Figure 30
1.2.9-2	A13.2	Figure 30
1.2.9-3	A13.3	Figure 30
1.2.9-4	A13.4	Figure 30
1.2.9-5	A13.5	Figure 30
1.2.9-6	A13.6	Figure 30
1.2.9-7	A13.7	Figure 30
1.2.9-8	A13.8	Figure 30
1.2.9-9	A13.9	Figure 30
1.2.9-10	A13.10	Figure 30
1.2.10-1	A14.1	Figure 31
1.2.11-1	A15.1	Figure 31
1.2.12-1	A16.1	NI
1.2.13-1	A17.1	Figure 31
1.2.14-1	A18.1	Figure 31
1.2.15-1	A19.1	Figure 31
1.2.15-2	A19.2	Figure 31
1.2.15-3	A19.3	Figure 31
1.2.15-4	A19.4	Figure 31
1.2.16-1	A20.1	Figure 31
1.2.17-1	A21.1	Figure 31
1.2.18-1	A22.1	Figure 31
1.2.18-2	A22.2	Figure 31
1.2.18-3	A22.3	Figure 31
1.2.19-1	A23.1	Figure 31
1.2.20-1	A24.1	Figure 32
1.2.20-2	A24.2	Figure 32
1.2.20-3	A24.3	Figure 32
1.2.20-4	A24.4	Figure 32
1.2.20-5	A24.5	Figure 32
1.2.20-6	A24.6	Figure 32
1.2.20-7	A24.7	Figure 32
1.2.20-8	A24.8	Figure 32
1.2.20-9	A24.9	Figure 32
1.2.20-10	A24.10	Figure 32
1.2.20-11	A24.11	Figure 32
2.1.1-1	B4.1	Figure 33
2.1.1-2	B4.2	Figure 33
2.1.1-3	B4.3	Figure 33

Old catalogue entry (Anastasi 2015)	New catalogue entry	Figure
2.1.2	B2.1	Figure 33
2.1.3	B3.1	Figure 33
2.1.4	B1.1	Figure 33
2.1.5-1	B5.1	Figure 33
2.1.5-2	B5.2	Figure 33
2.1.5-3	B5.3	Figure 33
2.1.5-4	B5.4	Figure 33
2.1.5-5	B5.5	Figure 33
2.1.6-1	B6.1	Figure 33
2.1.6-2	B6.2	Figure 33
2.1.7-1	B7.1	Figure 33
2.1.7-2	B7.2	Figure 33
2.1.8-1	B8.1	Figure 35
2.1.8-2	B8.2	Figure 35
2.1.9-1	B9.1	Figure 35
2.1.9-2	B9.2	Figure 35
2.1.9-3	B9.3	Figure 35
2.1.9-4	B9.4	Figure 35
2.1.10-1	B10.1	Figure 35
2.1.11-1	B11.1	Figure 35
2.1.12-1	B12.1	Figure 35
2.1.12-2	B12.2	Figure 35
2.1.13-1	B13.1	Figure 36
2.1.13-2	B13.2	Figure 36
2.1.13-3	B13.3	Figure 36
2.1.13-4	B13.4	Figure 36
2.1.13-5	B13.5	Figure 36
2.1.14-1	B14.1	Figure 36
2.1.15-1	B15.1	Figure 36
2.1.16-1	B16.1	Figure 36
2.1.16-2	B16.2	Figure 36
2.1.16-3	B16.3	Figure 36
2.1.16-4	B16.4	Figure 36
2.1.17-1	B17.1	Figure 36
2.1.18-1	B18.1	Figure 36
2.1.19-1	B19.1	Figure 36
2.1.20-1	B20.1	Figure 36
2.1.20-2	B20.2	Figure 36
2.1.20-3	B20.3	Figure 36
2.1.26-1	B21.1	Figure 37
2.1.27-1	B22.1	Figure 37
2.2.1-1	B23.1	Figure 37
2.2.1-2	B23.2	Figure 37
2.2.1-3	B23.3	Figure 37

Old catalogue entry (Anastasi 2015)	New catalogue entry	Figure
2.2.1-4	B23.4	Figure 37
2.2.1-5	B23.5	Figure 37
2.2.1-6	B23.6	Figure 37
2.2.1-7	B23.7	Figure 37
2.2.1-8	B23.8	Figure 37
2.2.1-9	B23.9	Figure 37
2.2.1-10	B23.10	Figure 37
2.2.1-11	B23.11	Figure 37
2.2.1-12	B23.12	Figure 37
2.2.2	B24.1	Figure 37
2.2.3	B25.1	Figure 37
2.2.4	B26.1	Figure 37
2.2.5	B27.1	Figure 37
2.3.1	B28.1	Figure 38
2.3.2	B29.1	Figure 38
2.3.3	B30.1	Figure 38
2.3.4	B31.1	Figure 38
2.3.5-1	B32.1	Figure 38
2.3.5-2	B32.2	Figure 38
2.4.1-1	B33.1	Figure 38
2.4.1-2	B33.2	Figure 38
2.4.2	B34	NI
2.4.3-1	B35.1	Figure 38
2.4.3-2	B35.2	Figure 38
2.5.1-1	B36.1	Figure 38
2.5.1-2	B36.2	Figure 38
2.5.2-1	B37.1	Figure 39
2.5.3-1	B38.1	Figure 39
2.5.4-1	B39.1	Figure 39
2.5.4-2	B39.2	Figure 39
2.5.4-3	B39.3	Figure 39
2.5.5.1	B40.1	NI
2.5.5.2	B40.2	Figure 39
2.5.5.3	B40.3	Figure 39
2.5.5.4-1	B40.4	Figure 39
2.5.5.4-2	B40.5	Figure 39
2.5.5.4-3	B40.6	Figure 39
2.5.5.4-4	B40.7	Figure 39
2.5.5.5	B40.8	Figure 39
2.5.5.6	B40.9	NI
2.5.5.7	B40.10	NI
2.5.5.8-1	B40.11	Figure 39
2.5.5.8-2	B40.12	Figure 39
2.5.5.9	B40.13	Figure 40

Old catalogue entry (Anastasi 2015)	New catalogue entry	Figure
2.5.5.10-1	B41.1	Figure 40
2.5.5.10-2	B41.2	Figure 40
2.5.5.10-3	B41.3	Figure 40
2.5.5.10-4	B41.4	Figure 40
3.1.1.1-1	C1.1	Figure 41
3.1.1.1-2	C1.2	Figure 41
3.1.1.2-1	C2.1	Figure 41
3.1.1.2-2	C2.2	Figure 41
3.1.1.3-1	C3.1	Figure 41
3.1.1.3-2	C3.2	Figure 41
3.1.1.4-1	C4.1	Figure 41
3.1.1.5-1	C5.1	Figure 41
3.1.1.6-1	C6.1	Figure 41
3.1.1.7-1	C7.1	Figure 41
3.1.1.7-2	C7.2	Figure 41
3.1.2.1-1	C8.1	Figure 42
3.1.2.2-1	C9.1	Figure 42
3.1.2.3-1	C10.1	Figure 42
3.1.3.1-1	C11.1	Figure 42
3.1.3.1-2	C11.2	Figure 42
3.1.3.1-3	C11.3	Figure 42
3.1.3.2-1	C12.1	Figure 42
3.1.3.2-2	C12.2	Figure 42
3.1.3.3-1	C13.1	Figure 42
3.1.3.4-1	C14.1	Figure 42
3.2.1.1-1	C15.1	Figure 43
3.2.1.2-1	C16.1	Figure 43
3.2.1.2-2	C16.2	Figure 43
3.2.1.2-3	C16.3	Figure 43
3.2.1.2-4	C16.4	Figure 43
3.2.1.2-5	C16.5	Figure 45
3.2.1.3-1	C17.1	Figure 45
3.2.1.3-2	C17.2	Figure 45
3.2.1.3-3	C17.3	Figure 45
3.2.1.3-4	C17.4	Figure 45
3.2.1.3-5	C17.5	Figure 45
3.2.1.4-1	C18.1	Figure 46
3.2.1.4-2	C18.2	Figure 46
3.2.2.1-1	C19.1	Figure 46
3.2.2.1-2	C19.2	Figure 46
3.3.1.1-1	C20.1	Figure 47
3.3.1.1-2	C20.2	Figure 47
3.3.1.2-1	C21.1	Figure 47
3.3.2.1-1	C22.1	Figure 47

Old catalogue entry (Anastasi 2015)	New catalogue entry	Figure
3.3.2.2-1	C23.1	Figure 47
3.3.2.3-1	C24.1	Figure 47
3.3.3.1-1	C25.1	Figure 47
3.3.3.1-2	C25.2	Figure 47
3.3.4.1-1	C26.1	Figure 48
3.3.4.1-2	C26.2	Figure 48
3.3.4.1-3	C26.3	Figure 48
3.3.5-1	C27.1	NI
3.4.1.1-1	C28.1	Figure 48
3.4.2.1-1	C29.1	Figure 48
3.4.2.1-2	C29.2	Figure 48
3.4.2.2-1	C30.1	Figure 48
3.4.2.3-1	C31.1	Figure 48
3.4.2.3-2	C31.2	Figure 49
3.4.2.3-3	C31.3	Figure 49
3.4.2.3-4	C31.4	Figure 49
3.4.2.4-1	C32.1	Figure 49
3.4.2.5-1	C33.1	Figure 49
3.4.2.5-2	C33.2	Figure 49
3.4.2.5-3	C33.3	Figure 49
3.4.2.5-4	C33.4	Figure 49
3.4.2.6-1	C34.1	Figure 50
3.4.2.6-2	C34.2	Figure 50
3.4.2.6-3	C34.3	Figure 50
3.4.2.7-1	C35.1	Figure 50
3.4.2.8-1	C36.1	Figure 50
3.4.2.9-1	C37.1	Figure 50
3.4.3.1-1	C38.1	Figure 50
3.4.3.1-2	C38.2	Figure 50
3.4.3.1-3	C38.3	Figure 50
3.4.3.1-4	C38.4	Figure 50
3.4.3.2-1	C39.1	Figure 51
3.4.3.2-2	C39.2	Figure 51
3.4.3.2-3	C39.3	Figure 51
3.4.3.2-4	C39.4	Figure 51
3.4.3.2-5	C39.5	Figure 51
3.4.3.3-1	C40.1	Figure 51
3.4.3.3-2	C40.2	Figure 51
3.4.3.3-3	C40.3	Figure 51
3.4.3.3-4	C40.4	Figure 51
3.4.3.3-5	C40.5	Figure 52
3.4.3.3-6	C40.6	Figure 52
3.4.3.4-1	C41.1	Figure 52
3.4.3.5-1	C42.1	Figure 52

Old catalogue entry (Anastasi 2015)	New catalogue entry	Figure
3.4.3.6-1	C43.1	Figure 52
3.4.3.6-2	C43.2	Figure 52
3.5.1.1-1	C44.1	Figure 52
3.5.1.1-2	C44.2	Figure 52
3.5.1.2-1	C45.1	Figure 52
3.5.2.1-1	C46.1	Figure 53
3.5.2.1-2	C46.2	Figure 53
3.5.2.1-3	C46.3	Figure 53
3.5.2.1-4	C46.4	Figure 53
3.5.2.1-5	C46.5	Figure 53
3.5.2.2-1	C47.1	Figure 53
3.5.2.2-2	C47.2	Figure 53
3.5.2.2-3	C47.3	Figure 53
3.5.2.2-4	C47.4	Figure 53
3.5.2.3-1	C48.1	Figure 54
3.5.2.3-2	C48.2	Figure 54
3.5.3.1-1	C49.1	Figure 54
3.5.3.1-2	C49.2	Figure 54
3.5.3.1-3	C49.3	Figure 54
3.5.3.2-1	C50.1	Figure 54
3.5.3.3-1	C51.1	Figure 54
3.5.3.3-2	C51.2	Figure 54
4.1.1-1	D1.1	Figure 55
4.1.1-2	D1.2	Figure 55
4.1.2-1	D2.1	Figure 55
4.1.3-1	D3.1	Figure 55
4.1.3-2	D3.2	Figure 55
4.1.3-3	D3.3	Figure 55
4.1.4-1	D4.1	Figure 55
4.1.4-2	D4.2	Figure 55
4.1.5-1	D5.1	Figure 55
4.1.5-2	D5.2	Figure 55
4.1.5-3	D5.3	Figure 55
4.1.5-4	D5.4	Figure 55
4.1.5-5	D5.5	Figure 55
4.1.5-6	D5.6	Figure 55
4.1.5-7	D5.7	Figure 55
4.1.5-8	D5.8	Figure 55
4.1.6-1	D6.1	Figure 56
4.1.6-2	D6.2	Figure 56
4.1.6-3	D6.3	Figure 56
4.1.6-4	D6.4	Figure 56
4.1.6-5	D6.5	Figure 56
4.1.6-6	D6.6	Figure 56

Old catalogue entry (Anastasi 2015)	New catalogue entry	Figure
4.1.7-1	D7.1	Figure 56
4.1.7-2	D7.2	Figure 56
4.1.7-3	D7.3	Figure 56
4.1.8-1	D8.1	Figure 56
4.1.8-2	D8.2	Figure 56
4.1.9-1	D9.1	Figure 56
4.1.9-2	D9.2	Figure 56
4.1.9-3	D9.3	Figure 56
4.1.9-4	D9.4	Figure 57
4.1.9-5	D9.5	Figure 57
4.1.9-6	D9.6	Figure 57
4.1.9-7	D9.7	Figure 57
4.1.9-8	D9.8	Figure 57
4.1.9-9	D9.9	Figure 57
4.1.9-10	D9.10	Figure 57
4.1.9-11	D9.11	Figure 57
4.1.10-1	D10.1	Figure 57
4.1.10-2	D10.2	Figure 57
4.1.10-3	D10.3	Figure 57
4.1.10-4	D10.4	Figure 57
4.1.10-5	D10.5	Figure 57
4.1.10-6	D10.6	Figure 57
4.1.10-7	D10.7	Figure 57
4.1.11-1	D11.1	Figure 58
4.1.11-2	D11.2	Figure 58
4.1.11-3	D11.3	Figure 58
4.1.11-4	D11.4	Figure 58
4.1.11-5	D11.5	Figure 58
4.1.11-6	D11.6	Figure 58
4.1.11-7	D11.7	Figure 58
4.1.11-8	D11.8	Figure 58
4.1.12-1	D12.1	Figure 58
4.1.12-2	D12.2	Figure 58
4.1.12-3	D12.3	Figure 58
4.1.12-4	D12.4	Figure 58
4.1.12-5	D12.5	Figure 58
4.1.12-6	D12.6	Figure 58
4.1.12-7	D12.7	Figure 58
4.1.12-8	D12.8	Figure 58
4.1.12-9	D12.9	Figure 58
4.1.12-10	D12.10	Figure 58
4.1.13-1	D13.1	Figure 59
4.1.14-1	D14.1	Figure 59
4.1.15-1	D15.1	Figure 59

Old catalogue entry (Anastasi 2015)	New catalogue entry	Figure
4.1.15-2	D15.2	Figure 59
4.1.15-3	D15.3	Figure 59
4.1.15-4	D15.4	Figure 59
4.1.15-5	D15.5	Figure 59
4.1.15-6	D15.6	Figure 59
4.1.15-7	D15.7	Figure 59
4.1.15-8	D15.8	Figure 59
4.1.15-9	D15.9	Figure 59
4.1.15-10	D15.10	Figure 59
4.1.15-11	D15.11	Figure 59
4.1.15-12	D15.12	Figure 59
4.1.15-13	D15.13	Figure 59
4.1.15-14	D15.14	Figure 59
4.1.16-1	D16.1	Figure 60
4.1.16-2	D16.2	Figure 60
4.1.17-1	D17.1	Figure 60
4.1.17-2	D17.2	Figure 60
4.1.17-3	D17.3	Figure 60
4.1.18-1	D18.1	Figure 60
4.1.18-2	D18.2	Figure 60
4.1.18-3	D18.3	Figure 60
4.1.19-1	D19.1	Figure 60
4.1.20-1	D20.1	Figure 60
4.1.21-1	D21.1	Figure 60
4.1.22-1	D22.1	Figure 61
4.1.22-2	D22.2	Figure 61
4.1.22-3	D22.3	Figure 61
4.1.22-4	D22.4	Figure 61
4.1.23-1	D23.1	Figure 61
4.1.24-1	D24.1	Figure 61
4.1.25-1	D25.1	Figure 61
4.1.25-2	D25.2	Figure 61
4.1.25-3	D25.3	Figure 61
4.1.26-1	D26.1	Figure 61
4.1.26-2	D26.2	Figure 61
4.1.26-3	D26.3	Figure 62
4.1.27-1	D27.1	Figure 62
4.1.27-2	D27.2	Figure 62
4.1.27-3	D27.3	Figure 62
4.1.27-4	D27.4	Figure 62
4.1.27-5	D27.5	Figure 62
4.1.27-6	D27.6	Figure 62
4.1.27-7	D27.7	Figure 62
4.1.27-8	D27.8	Figure 62

Old catalogue entry (Anastasi 2015)	New catalogue entry	Figure
4.1.27-9	D27.9	Figure 62
4.1.28-1	D28.1	Figure 62
4.1.29-1	D29.1	Figure 63
4.1.29-2	D29.2	Figure 63
4.1.29-3	D29.3	Figure 63
4.1.29-4	D29.4	Figure 63
4.1.30-1	D30.1	Figure 63
4.1.31-1	D31.1	Figure 63
4.2.1-1	D32.1	Figure 64
4.2.2-1	D33.1	Figure 64
4.2.3-1	D34.1	Figure 64
4.2.3-2	D34.2	Figure 64
4.2.3-3	D34.3	Figure 64
4.2.3-4	D34.4	Figure 64
4.2.3-5	D34.5	Figure 64
4.2.4-1	D35.1	Figure 65
4.2.4-2	D35.2	Figure 65
4.3.1-1	D36.1	Figure 66
4.3.1-2	D36.2	Figure 66
4.3.1-3	D36.3	Figure 66
4.3.1-4	D36.4	Figure 66
4.3.1-5	D36.5	Figure 66
4.3.1-6	D36.6	Figure 66
4.3.2-1	D37.1	Figure 66
4.3.2-2	D37.2	Figure 66
4.3.3-1	D38.1	Figure 67
4.3.3-2	D38.2	Figure 67
4.3.3-3	D38.3	Figure 67
4.3.3-4	D38.4	Figure 67
4.3.4-1	D39.1	Figure 67
4.3.4-2	D39.2	Figure 67
4.3.5-1	D40.1	Figure 67
4.3.5-2	D40.2	Figure 67
4.3.5-3	D40.3	Figure 67
4.3.5-4	D40.4	Figure 68
4.3.5-5	D40.5	Figure 68
4.3.6-1	D41.1	Figure 68
4.3.6-2	D41.2	Figure 68
4.3.6-3	D41.3	Figure 68
4.3.6-4	D41.4	Figure 68
4.3.7-1	D42.1	Figure 68
4.3.7-2	D42.2	Figure 68
4.3.7-3	D42.3	Figure 68
4.3.7-4	D42.4	Figure 68

Old catalogue entry (Anastasi 2015)	New catalogue entry	Figure
4.3.7-5	D42.5	Figure 69
4.3.7-6	D42.6	Figure 69
4.3.8-1	D43.1	Figure 69
4.3.9-1	D44.1	Figure 69
4.3.10-1	D45.1	Figure 69
4.3.10-2	D45.2	Figure 69
4.3.10-3	D45.3	Figure 69
4.3.10-4	D45.4	Figure 69
4.3.10-5	D45.5	Figure 70
4.3.11-1	D46.1	Figure 70
4.3.11-2	D46.2	Figure 70
4.3.11-3	D46.3	Figure 70
4.3.11-4	D46.4	Figure 70
4.3.11-5	D46.5	Figure 70
4.3.12-1	D47.1	Figure 70
4.3.12-2	D47.2	Figure 70
4.3.13-1	D48.1	Figure 70
4.3.13-2	D48.2	Figure 70
4.3.14-1	D49.1	Figure 70
4.3.14-2	D49.2	Figure 70
4.3.14-3	D49.3	Figure 70
4.3.14-4	D49.4	Figure 70
4.3.14-5	D49.5	Figure 70
4.3.14-6	D49.6	Figure 70
4.3.15-1	D50.1	Figure 71
4.3.15-2	D50.2	Figure 71
4.3.15-3	D50.3	Figure 71
4.3.16-1	D51.1	Figure 71
4.3.16-2	D51.2	Figure 71
4.3.16-3	D51.3	Figure 71
4.3.16-4	D51.4	Figure 71
4.3.16-5	D51.5	Figure 71
4.3.16-6	D51.6	Figure 71
4.3.16-7	D51.7	Figure 71
4.3.17-1	D52.1	Figure 72
4.3.18-1	D53.1	Figure 73
4.3.18-2	D53.2	Figure 73
4.3.18-3	D53.3	Figure 73
4.3.18-4	D53.4	Figure 73
4.4.1-1	D54.1	Figure 74
4.4.1-2	D54.2	Figure 74
4.4.1-3	D54.3	Figure 74
4.4.1-4	D54.4	Figure 74
4.4.1-5	D54.5	Figure 74

Old catalogue entry (Anastasi 2015)	New catalogue entry	Figure
4.4.2-1	D55.1	Figure 74
4.4.2-2	D55.2	Figure 74
4.4.2-3	D55.3	Figure 74
4.4.2-4	D55.4	Figure 74
4.4.2-5	D55.5	Figure 74
4.4.2-6	D55.6	Figure 75
4.4.2-7	D55.7	Figure 75
4.4.3-1	D56.1	Figure 75
4.4.4-1	D57.1	Figure 75
4.4.4-2	D57.2	Figure 75
4.4.4-3	D57.3	Figure 75
4.4.4-4	D57.4	Figure 75
4.4.5-1	D58.1	Figure 76
4.4.5-2	D58.2	Figure 76
4.4.5-3	D58.3	Figure 76
4.4.6-1	D59.1	Figure 76
4.4.7-1	D60.1	Figure 76
4.4.7-2	D60.2	Figure 76
4.4.7-3	D60.3	Figure 76
4.4.7-4	D60.4	Figure 76
4.4.7-5	D60.5	Figure 76
4.4.7-6	D60.6	Figure 76
4.4.7-7	D60.7	Figure 76
4.4.8-1	D61.1	Figure 76
4.4.8-2	D61.2	Figure 76
4.4.8-3	D61.3	Figure 76
4.4.9-1	D62.1	Figure 76
4.4.9-2	D62.2	Figure 76
4.4.9-3	D62.3	Figure 76
4.4.9-4	D62.4	Figure 76
4.4.10-1	D63.1	Figure 78
4.4.10-2	D63.2	Figure 78
4.4.10-3	D63.3	Figure 78
4.4.10-4	D63.4	Figure 78
4.4.11-1	D64.1	Figure 78
4.4.11-2	D64.2	Figure 78
4.4.11-3	D64.3	Figure 78
4.4.11-4	D64.4	Figure 78
4.4.11-5	D64.5	Figure 78
4.4.11-6	D64.6	Figure 78
4.4.12-1	D65.1	Figure 78
4.4.12-2	D65.2	Figure 78
4.4.13-1	D66.1	Figure 78
4.4.14-1	D67.1	Figure 78



Old catalogue entry (Anastasi 2015)	New catalogue entry	Figure
4.4.14-2	D67.2	Figure 78
4.4.14-3	D67.3	Figure 78
4.4.14-4	D67.4	Figure 78
4.4.14-5	D67.5	Figure 78
4.4.14-6	D67.6	Figure 78
4.4.14-7	D67.7	Figure 81
4.4.14-8	D67.8	Figure 81
4.4.14-9	D67.9	Figure 81
4.4.14-10	D67.10	Figure 81
4.4.14-11	D67.11	Figure 81
4.4.15-1	D68.1	Figure 81
4.4.15-2	D68.2	Figure 81
4.4.16-1	D69.1	Figure 81
4.4.16-2	D69.2	Figure 81
4.5.1-1	D70.1	Figure 82
4.5.1-2	D70.2	Figure 82
4.5.1-3	D70.3	Figure 82
4.5.2-1	D71.1	Figure 82
4.5.2-2	D71.2	Figure 82
4.5.2-3	D71.3	Figure 82
4.5.2-4	D71.4	Figure 82
4.5.2-5	D71.5	Figure 82
4.5.3-1	D72.1	Figure 83
4.5.4-1	D73.1	Figure 83
4.5.4-2	D73.2	Figure 83
4.5.5-1	D74.1	Figure 83
4.5.5-2	D74.2	Figure 83
4.5.5-3	D74.3	Figure 83
4.5.5-4	D74.4	Figure 83
4.5.6-1	D75.1	Figure 84
4.5.7-1	D76.1	Figure 84
4.5.7-2	D76.2	Figure 84
4.5.7-3	D76.3	Figure 84
4.5.8-1	D77.1	Figure 84
4.5.9-1	D78.1	Figure 84
4.5.9-2	D78.2	Figure 84
4.5.10-1	D79.1	Figure 84
4.6.1-1	D80.1	Figure 85
4.6.1-2	D80.2	Figure 85
4.6.1-3	D80.3	Figure 85
4.6.1-4	D80.4	Figure 85
4.7.1-1	L1.1	Figure 86
4.7.2-1	L2.1	Figure 86
4.7.2-2	L2.2	Figure 86

Old catalogue entry (Anastasi 2015)	New catalogue entry	Figure
4.8.1-1	M1.1	Figure 87
4.8.2-1	M2.1	Figure 87
4.8.2-2	M2.2	Figure 87
4.8.3-1	M3.1	Figure 87
4.8.4-1	M4.1	Figure 87
4.8.5-1	M5.1	Figure 87
4.8.6-1	M6.1	Figure 87

## Appendix 2: Pottery quantification

Within this appendix, the pottery studied for this research (the three Maltese assemblages from Bulebel, Foreman Street and the Melita Esplanade) has been quantified according to the classification system devised for catalogue in this volume.. The data are presented in a series of tables (amphorae, fine wares, cooking wares and coarse wares), which have been organised in a manner that distinguishes between each assemblage and the various phases within each.

The material was divided according to the types listed within the catalogue (i.e. A1=Sagona amphora forms IV-V:1/IV:1, A2=Malta type 1 etc.). The material was further divided into assemblages (i.e. Bulebel, Foreman Street etc.), phases, total number of fragments (RBHS) and suspected minimum number of individuals (MNI). Fragments that could not be classified according to a specific type were classed under more general categories (IA=Imported amphorae, IA Aeg.= Aegean amphorae etc.), and listed below the more specific types.

AMPHORAE																							
TYPE	BULEBEL								FOREMAN STR.		MELITA (MUSEUM ESPLANADE)								TOTAL				
	Phase 1		Phase 2		Tomb 1		Tomb 3		Total		Qty	MNI	Phase 1		Phase 2		Phases 3-5		Total		Qty	MNI	
	Qty	MNI	Qty	MNI	Qty	MNI	Qty	MNI	Qty	MNI			Qty	MNI	Qty	MNI	Qty	MNI	Qty	MNI			Qty
A1	5	4	4	4					9	8			10	4	6	4	5	5	21	13	30	21	
A2	16	9	4	4					20	13					1	1	2	2	3	3	23	16	
A3											1	1					1	1	1	1	2	2	
A4																	2	2	2	2	2	2	
A5																	2	2	2	2	2	2	
A6			1	1					1	1					1	1	2	2	3	3	4	4	
A7																	1	1	1	1	1	1	
A8			1	1					1	1											1	1	
A9	34	13	8	5					42	18			1	1	3	2	2	1	6	4	48	22	
A10	19	3	5	4					24	7							1	1	1	1	25	8	
A11			54	10					54	10					39	2			39	2	93	12	
A12			63	7					63	7								3	3	3	3	66	10
A13																	59	14	59	14	59	14	
A14			2	1					2	1											2	1	
A15			1	1					1	1											1	1	
A16																	5	2	5	2	5	2	
A17																	2	2	2	2	2	2	
A18																	1	1	1	1	1	1	
A19			163	1					163	1							7	4	7	4	170	5	
A20																	1	1	1	1	1	1	
A21																	1	1	1	1	1	1	
A22																	10	7	10	7	10	7	
A23																	3	1	3	1	3	1	
A24	2	2	2	2					4	4	3	3	3	3			11	10	14	13	21	20	
A24 Adr.	1	1	1	1					2	2							2	1	2	1	4	3	
A24 Aeg.																	1	1	1	1	1	1	
A24 Afr.			2	2					2	2											2	2	
A24 East															14	1	2	2	16	3	16	3	
LMA	73	46	36	15	2	2			111	63			1	1	4	2	6	6	11	9	122	72	
IA	74	22	72	24			2	2	148	48	27	27	5	2	4	2	35	24	44	28	219	103	
IA Adr.	79	12	133	27	1	1	1	1	214	41			29	6			9	9	38	15	252	56	
IA Afr.	16	12	150	18	2	2			168	32	63	63	4	4	43	7	106	56	153	67	384	162	
IA P. Afr.	8	2							8	2					4	3	1	1	5	4	13	6	
IA Camp.	17	7	87	11					104	18			2	2	22	3	3	3	27	8	131	26	
IA East	7	1							7	1	6	6					15	10	15	10	28	17	
IA Gr. It.	3	3	1	1					4	4											4	4	
IA Imp.			1	1					1	1											1	1	
IA Rep.	3	2	7	2					10	4			1	1			1	1	2	2	12	6	
IA Sic.	3	2	180	22					183	24			25	4	4	2	13	9	42	15	225	39	
IA Sp.	46	2	6	1					52	3											52	3	
<b>TOTAL</b>	<b>406</b>	<b>143</b>	<b>984</b>	<b>166</b>	<b>5</b>	<b>5</b>	<b>3</b>	<b>3</b>	<b>1398</b>	<b>317</b>	<b>100</b>	<b>100</b>	<b>81</b>	<b>28</b>	<b>145</b>	<b>30</b>	<b>315</b>	<b>186</b>	<b>541</b>	<b>244</b>	<b>2039</b>	<b>661</b>	

IA=Imported amphorae; LMA=Local Maltese amphorae; Adr.=Adriatic; Afr.=North African; P. Afr.=Punic; North African; Camp.=Campanian; East=Eastern Mediterranean; Gr. It.=Greco Italic; Imp.=Imperial Roman; Rep.=Republican Roman; Sic.=Sicilian; Sp.=Spanish

FINE WARES																							
TYPE	BULEBEL										FOREMAN STREET		MELITA (MUSEUM ESPLANADE)						TOTAL				
	Phase 1		Phase 2		Tomb 1		Tomb 3		Total		Qty	MNI	Phase 1	Phase 2	Phases 3-5		Total		Qty	MNI			
	Qty	MNI	Qty	MNI	Qty	MNI	Qty	MNI	Qty	MNI					Qty	MNI	Qty	MNI			Qty	MNI	
B1	1	1								1	1								1	1			
B2			1	1						1	1								1	1			
B3			1	1						1	1								1	1			
B4			6	3						6	3								7	4			
B5															2	1	2	1	7	6			
B6																			3	3			
B7															2	1	2	1	4	3			
B8			2	1						2	1								3	2			
B9								7	2	7	2								18	11			
B10								4	1	4	1								4	1			
B11								14	1	14	1								14	1			
B12								8	1	8	1			1	1			1	1	9	2		
B13															12	9	12	9	12	9			
B14															2	2	2	2	2	2			
B15															1	1	1	1	1	1			
B16												1	1		5	5	5	5	6	6			
B17															1	1	1	1	1	1			
B18															1	1	1	1	1	1			
B19															1	1	1	1	1	1			
B20	2	2	11	10	1	1				14	13	34	34		10	10	160	103	170	113	218	160	
B21	1	1								1	1										1	1	
B22			8	1						8	1										8	1	
B23	7	6	12	12						19	18										19	18	
B24	1	1	1	1						2	2										2	2	
B25			6	1						6	1										6	1	
B26															1	1	1	1	1	1	1	1	
B27												13	1					13	1	13	1		
LTW	3	2	18	12						21	14				3	2	4	3	7	5	28	19	
B28			1	1						1	1										1	1	
B29			1	1						1	1										1	1	
B30	1	1								1	1										1	1	
B31			1	1						1	1										1	1	
B32												2	2								2	2	
ITW			2	2						2	2	4	4	2	1			1	1	3	2	9	8
B33			2	2						2	2							1	1	1	1	3	3
B34	2	2	1	1						3	3				1	1	4	4	5	5	8	8	
B35	4	2	3	2						7	4				1	1			1	1	8	5	
B36			4	2						4	2						1	1	1	1	5	3	
B37			1	1						1	1										1	1	
B38			3	3						3	3	1	1		1	1	1	1	2	2	6	6	
B39												8	6								8	6	
B40.1															3	1	3	1	3	1	3	1	
B40.2										1	1										1	1	
B40.4-7							26	1		26	1	1	1		1	1	1	1	1	1	28	3	
B40.8															1	1	1	1	1	1	1	1	
B40.9															1	1	1	1	1	1	1	1	
B40.11-12					59	1	50	1		109	2				29	13	29	13	138	15	138	15	
B40.13															1	1	1	1	1	1	1	1	
B41												6	6		1	1	8	6	9	7	15	13	
B40 Misc.												16	16		3	2	69	46	72	48	88	64	
IRS												2	1								2	1	
IFW																	3	3	3	3	3	3	
<b>TOTAL</b>	<b>22</b>	<b>18</b>	<b>85</b>	<b>59</b>	<b>60</b>	<b>2</b>	<b>109</b>	<b>7</b>	<b>276</b>	<b>86</b>	<b>88</b>	<b>85</b>	<b>15</b>	<b>2</b>	<b>21</b>	<b>19</b>	<b>327</b>	<b>219</b>	<b>363</b>	<b>240</b>	<b>727</b>	<b>411</b>	

LTW=Local thin-walled ware; ITW=Imported thin-walled ware; Misc.=Miscellaneous; IRS=Imported red-slipped ware; IFW=Imported fine ware.

POTTERY FROM ROMAN MALTA

COOKING WARES																								
TYPE	BULEBEL								FOREMAN STREET		MELITA (MUSEUM ESPLANADE)								TOTAL					
	Phase 1		Phase 2		Tomb 1		Tomb 3		Total		Qty	MNI	Phase 1		Phase 2		Phases 3-5		Total		Qty	MNI		
	Qty	MNI	Qty	MNI	Qty	MNI	Qty	MNI	Qty	MNI			Qty	MNI	Qty	MNI	Qty	MNI	Qty	MNI			Qty	MNI
C1	11	5	12	7					23	12							1	1	1	1	24	13		
C2	6	2							6	2											6	2		
C3			3	3					3	3			1	1	1	1				2	2	5	5	
C4																	1	1		1	1	1	1	
C5											1	1											1	1
C6											1	1											1	1
C7																	1	1		1	1	1	1	
C8	1	1							1	1													1	1
C9			4	1					4	1													4	1
C10	6	1							6	1													6	1
C11	2	2	1	1					3	3							4	3		4	3	7	6	
C12	1	1							1	1				1	1	2	2		3	3	4	4		
C13																	2	1		2	1	2	1	
C14			4	4					4	4													4	4
LKW	16	16	5	5	5	5	3	3	29	29			14	7	18	16	13	10	44	33	74	62		
C15	11	10	10	10	1	1			22	21					1	1	9	6	10	7	32	28		
C16	39	11	5	5					44	16											44	16		
C17	5	5	47	34					52	39	2	2			3	3	7	2	10	5	64	46		
C18																	3	3	3	3	3	3	3	
C19	91	91	150	100	4	4	1	1	246	196	11	11	8	1	7	7	24	20	39	28	296	235		
C20			1	1					1	1							1	1	1	1	2	2		
C21																	2	1	2	1	2	1		
C22			1	1					1	1											1	1		
C23			4	1					4	1											4	1		
C24														1	1				1	1	1	1		
C25	1	1	2	1					3	2											3	2		
C26			17	3					17	3											17	3		
C27																	1	1	1	1	1	1		
IKW It. Aeg.			12	12	2	2			14	14	2	2	11	3	4	4	19	16	34	23	50	38		
C28																			3	1	3	1		
C29											2	2									2	2		
C30											1	1									1	1		
C31			4	2					4	2	1	1					14	4	14	4	19	7		
C32											2	1									2	1		
C33											1	1					5	3	5	3	6	4		
C34											12	12					6	6	6	6	18	18		
C35																	13	11	13	11	13	11		
C38											1	1							1	1	2	2		
C39			1	1					1	1	5	5			3	2	9	9	12	11	18	17		
C40											6	6			4	1	11	11	15	12	21	18		
C41			1	1					1	1	1	1									2	2		
C42											1	1									1	1		
C43											1	1									1	1		
IKW Afr.											38	38			10	6	121	86	131	92	169	130		
C44											2	2									2	2		
C45											1	1									1	1		
C46											12	12					6	4	6	4	18	16		
C47																	13	6	13	6	13	6		
C48																	2	2	2	2	2	2		
C49			1	1					1	1							2	2	2	2	3	3		
C50											1	1					1	1	1	1	2	2		
C51											2	2									2	2		
IKW Pant.			3	3					3	3	40	40			2	2	27	20	29	22	72	65		
IKW															1	1	12	3	13	4	13	4		
TOTAL	190	146	288	197	12	12	4	4	494	359	147	146	34	12	60	48	332	237	426	297	1067	802		

LKW=Local cooking ware; IKW=Imported cooking ware; It. Aeg.=Italian/Aegean; Afr.=North African; Pant.=Pantellerian ware.

COARSE WARES																						
TYPE	BULEBEL								FOREMAN STREET		MELITA (MUSEUM ESPLANADE)						TOTAL					
	Phase 1		Phase 2		Tomb 1		Tomb 3		Total		Qty	MNI	Phase 1		Phase 2		Phases 3-5		Total		Qty	MNI
D1	1	1	3	3					4	4	2	2									6	6
D2			3	3					3	3					1	1	1	1	2	2	5	5
D3											1	1			1	1	1	1	2	2	3	3
D4	3	1							3	1											3	1
D5	2	2	16	15					18	17					1	1	7	6	8	7	26	24
D6	15	14	7	7					22	21	9	9	21	1	2	2	3	3	26	6	57	36
D7	2	2	1	1					3	3							6	5	6	5	9	8
D8	7	2							7	2											7	2
D9											253	253									253	253
D10											81	81									81	81
D11											84	84									84	84
D12											78	78									78	78
D13											2	2									2	2
D14											1	1									1	1
D15											60	60									60	60
D16	1	1							1	1	1	1									2	2
D17																	9	7	9	7	9	7
D18							46	4	46	4											46	4
D19																	1	1	1	1	1	1
D20			1	1					1	1											1	1
D21																	1	1	1	1	1	1
D22											6	6									6	6
D23			2	2					2	2							3	3	3	3	5	5
D24															1	1			1	1	1	1
D25	5	3							5	3											5	3
D26	3	3	4	4					7	7							3	3	3	3	10	10
D27	7	6	50	36					57	42			1	1	1	1	11	11	13	13	70	55
D28																	3	3	3	3	3	3
D29			17	7					17	7											17	7
D30																	2	1	2	1	2	1
D31											1	1									1	1
D32	6	1							6	1											6	1
D33			1	1					1	1											1	1
D34			5	4					5	4							1	1	1	1	6	5
D35			1	1					1	1							1	1	1	1	2	2
D36	6	6	7	7					13	13							4	3	4	3	17	16
D37	10	2	2	2					12	4							5	5	5	5	17	9
D38			4	4					4	4											4	4
D39											43	43			1	1					43	43
D40			1	1					1	1											42	42
D41											4	4					20	17	20	17	24	21
D42											3	3	1	1			17	13	18	14	21	17
D43																	1	1	1	1	1	1
D44															1	1	2	2	3	3	3	3
D45															1	1	10	8	11	9	11	9
D46	8	1	1	1					9	2	3	3									12	5
D47	1	1	4	3					5	4							1	1	1	1	6	5
D48											2	2									2	2
D49											9	9									9	9
D50											2	2									2	2
D51	6	3	9	7					15	10	1	1					1	1	1	1	17	12
D52	2	2	3	3					5	5	2	2					1	1	1	1	8	8
D53	12	12	30	29	1	1			43	42	11	11			6	6	23	18	29	24	83	77
D53 Afr.																	2	2	2	2	2	2
D54	2	2	3	3					5	5					2	2	3	2	5	4	10	9
D55	2	2	86	6	1	1			89	9					3	1	2	2	5	3	94	12
D56			2	1					2	1											2	1
D57	16	12	21	20					37	32	4	4			1	1	5	5	6	6	47	42
D58			1	1					1	1							3	3	3	3	4	4

POTTERY FROM ROMAN MALTA

TYPE	BULEBEL										FOREMAN STREET		MELITA (MUSEUM ESPLANADE)								TOTAL			
	Phase 1		Phase 2		Tomb 1		Tomb 3		Total		Qty	MNI	Qty	MNI	Phase 1		Phase 2		Phases 3-5		Total		Qty	MNI
	Qty	MNI	Qty	MNI	Qty	MNI	Qty	MNI	Qty	MNI					Qty	MNI	Qty	MNI	Qty	MNI	Qty	MNI		
D59			2	1					2	1													2	1
D60	1	1							1	1	25	25							4	4	4	4	30	30
D61											31	31											31	31
D62											4	4											4	4
D63	11	3	15	7					26	10													26	10
D64											25	25											25	25
D65			2	2	36	1	44	2	82	5						4	2	44	23	48	25	130	30	
D66							17	1	17	1													17	1
D67			30	4			30	1	60	5	6	6						3	3	3	3	69	14	
D68											1	1						4	1	4	1	5	2	
D69																		2	2	2	2	2	2	2
Trefoil jug			5	4	75	1			80	5	3	3						6	6	6	6	89	14	
D70	2	2	1	1					3	3													3	3
D71	12	2	8	7					20	9						1	1	1	1	2	2	22	11	
D72	1	1							1	1													1	1
D73	1	1							1	1													1	1
D74	62	1	3	2					65	3						2	2	1	1	3	3	68	6	
D75			1	1					1	1													1	1
D76	1	1	2	2					3	3								2	2	2	2	5	5	
D77																		1	1	1	1	1	1	1
D78	6	3	2	2					8	5						1	1			1	1	9	6	
D79	16	4	1	1					17	5								1	1	1	1	18	6	
Misc. Dolia	52	30	152	51					204	81	5	5	2	2	3	3	20	14	25	19	234	105		
D80	1	1	8	5					9	6						1	1	2	2	3	3	12	9	
L1	1	1							1	1													1	1
L2			2	2	48	4			52	8								1	1	1	1	53	9	
Lamps Misc.																		3	3	3	3	3	3	3
Lamps Afr.											1	1											1	1
Lamps Imp.																		6	5	6	5	6	5	6
Lamps Pun.											1	1											1	1
M1											1	1											1	1
M2											2	2											2	2
M3											1	1											1	1
M4											1	1											1	1
M5			1	1					1	1													1	1
LCW	427	364	994	867	16	14	18	18	1455	1263	2436	2436	37	26	76	64	383	325	496	373	4387	4114		
ICW			11	11					11	11	21	21			9	4	19	12	28	16	60	48		
ICW Camp.									1	1							3	3	3	3	4	4		
ICW Afr.			12	12	2	2			14	14	1	1	2	2	4	1	1	1	7	4	22	19		
TOTAL	711	494	1537	1156	179	24	155	26	2584	1702	3272	3272	63	32	123	99	659	542	845	673	6701	5647		

LCW=Local coarse ware; ICW=Imported coarse ware; Afr.=North African; Camp.=Campanian; Imp.=Imported; Misc.=Miscellaneous; Pun.=Punic.

## References

- ABELA, G.-F. 1647. *Della Descrittione di Malta Isola nel Mare Siciliano*. Malta.
- ALLISON, P.M. 2004. *Pompeian Households: An Analysis of the Material Culture*. Los Angeles: Cotsen Institute of Archaeology, University of California.
- ANASTASI, M. 2010. Coarse and Fine Wares: A Contextual Meaning of Pottery in Late Punic and Roman Malta. Unpublished M.A. dissertation. Malta: University of Malta.
- ANASTASI, M. 2012. The pottery from the 1972 excavation at the Żejtun villa, in R. ABELA (ed.) *The Żejtun Roman Villa: Research, Conservation, Management*: 26-41. Malta: Wirt iż-Żejtun.
- ANASTASI, M. 2015. Small-Island Interactions: Pottery from Roman Malta. Unpublished DPhil dissertation. Oxford: University of Oxford.
- ANASTASI, M. 2016. Appendix 3: African ceramics in Roman Malta: An overview, in D. MALFITANA and M. BONIFAY (eds) *La ceramica africana nella Sicilia romana/La céramique africaine dans la Sicile romaine*: 581-84. Catania: Centre Camille Jullian.
- ANASTASI, M. 2018. Tracing identity from insularity: Maltese industries in the Late Punic and Roman period, in A. KOUREMENOS (ed.) *Insularity and Identity in the Roman Mediterranean*: 125-43. Oxford: Oxbow.
- ANASTASI, M. and N.C. VELLA. 2018. Olive oil pressing technology in Roman Malta, in N.C. VELLA, A.J. FRENDO, and H.C.R. VELLA (eds) *The Lure of the Antique: Essays on Malta and Mediterranean Archaeology in Honour of Anthony Bonanno*: 275-300. Leuven: Peeters.
- ANTICO GALLINA, M. 2004. *Fra utilitas e salubritas: esempi maltesi di bonifica con strutture ad anfore*, in M. ANTICO GALLINA (ed.) *Acque per l'utilitas, per la salubritas, per l'amoenitas*: 245-71. Milan: Edizioni Et.
- ASCIAK, G. 2018. Characterisation and Identificatoin of Fossil and Mineral Inclusions in Roman Pottery from One Site in Victoria, Gozo. Unpublished MA dissertation. Malta: University of Malta.
- AURIEMMA, R. 2000. Le anfore del relitto di Grado e il loro contenuto. *Mélanges de l'école française de Rome* 112(1): 27-51.
- BALDASSARI, R. 2009. Il materiale del carico del relitto: analisi tipologica e quantitative della ceramica locale da fuoco, in S. TUSA, S. ZANGARA, and R. LA ROCCA (eds) *Il Relitto Tardo-Antico di Scauri a Pantelleria*: 91-106. Palermo: Regione Siciliana.
- BARONE, G., P. MAZZOLENI, S. RANERI, A. GIUFFRIDA and D. TANASI 2015. Archaeometric characterization of Middle Bronze Age pottery from the settlement at Borg in-Nadur, in D. TANASI and N.C. VELLA (eds) *The Late Prehistory of Malta: Essays on Borġ In-Nadur and Other Sites*: 99-112. Oxford: Archaeopress.
- BATS, M. 1993a. Céramique commune italique, in M. PY, A.M. ADROHER and C. RAYNAUD (eds) *Dicocer: dictionnaire des céramiques antiques (VIIème s.av.n.è. - VIIème s.de.n.è.) en Méditerranée nord-occidentale (Provence, Languedoc, Ampurdan)*: 357-62. Caveirac: Association pour la recherche archéologique en Languedoc oriental.
- BATS, M. 1993b. Céramique commune grecque, in M. PY, A.M. ADROHER and C. RAYNAUD (eds) *Dicocer: dictionnaire des céramiques antiques (VIIème s.av.n.è. - VIIème s.de.n.è.) en Méditerranée nord-occidentale (Provence, Languedoc, Ampurdan)*: 345-50. Caveirac: Association pour la recherche archéologique en Languedoc oriental.
- BATS, M. (ed.) 1996. *Les Céramiques Communes de Campanie et de Narbonnaise: La Vaisselle de Cuisine et de Table* (Collection du Centre Jean Bérard 14). Naples: Centre Jean Bérard.
- BECHTOLD, B. 2010. *The Pottery Repertoire from Late 6th-Mid 2nd Century BC Carthage: Observations based on the Bir Messaouda Excavations* (Carthage Studies 4). Gent: Gent University.
- BECHTOLD, B. 2012. Amphora Production in Punic Sicily (7th-3rd/2nd centuries B.C.E). An Overview, in *FACEM* (version 06/12/2012) (<http://www.facem.at/project-papers.php>).
- BECHTOLD, B. 2018. La distribuzione di anfore da trasporto Maltesi fuori dall'arcipelago: nuovi dati, in N.C. VELLA, A.J. FRENDO AND H.C.R. VELLA (eds) *The Lure of the Antique: Essays on Malta and Mediterranean Archaeology in Honour of Anthony Bonanno*: 257-274. Leuven: Peeters.
- BLAGG, T.F.C., A. BONANNO and A.T. LUTTRELL 1990. *Excavations at Hal Millieri, Malta*. Malta: University of Malta.
- BONANNO, A. 2005. *Malta. Phoenician, Punic and Roman*. Malta: Midsea.
- BONANNO, A. 2007. The economic history of Roman and Byzantine Malta (review article), *Journal of Roman Archaeology* 20: 519-524.
- BONANNO, A. AND N.C. VELLA 2012. Past and present excavations of a multi-period site, in R. ABELA (ed.) *The Żejtun Roman Villa: Research, Conservation and Management*, 8-25. Malta: Wirt iż-Żejtun.
- BONANNO, A. AND N.C. VELLA (eds) 2015. *Tas-Silġ, Marsaxlokk (Malta): I: Archaeological Excavations Conducted by the University of Malta, 1996-2005*. Leuven: Peeters.
- BONELLO, V., V. Borg, M. Cagiano de Azevedo, A. Ciasca, E. Coleiro, A. Davico, G. Garbini, S. Moscati, F.A. Pennacchietti, B. Pugliese, and V. Scrinari 1964. *Missione archeologica italiana a Malta: Rapporto preliminare della campagna 1963*. Roma: Università di Roma 'La Sapienza'.
- BONIFAY, M. 2004. *Etudes sur la céramique romaine tardive d'Afrique*. Oxford: Archaeopress.

- BONIFAY, M. 2016. Annexe 1: Éléments de typologie des céramiques de l'Afrique romaine, in D. MALFITANA and M. BONIFAY (eds) *La ceramica africana nella Sicilia romana/La céramique africaine dans la Sicile romaine: 507-73*. Catania: Centre Camille Jullian.
- BONIFAY, M., C. CAPELLI, C. FRANCO, L. LEITCH, L. RICCARDI, and P. BERNI MILLET 2013. Les Thermes du Levant à Leptis Magna: quatre contextes céramiques des III<sup>e</sup> et IV<sup>e</sup> siècles, *Antiquités africaines* 49: 67-150.
- BOZZI, C., M. CAGIANO DE AZEVEDO, C. CAPRINO, A. CIASCA, A. DAVICO, R. DEL MONACO, G. GARBINI, B. PUGLIESE and M.P. ROSSIGNANI 1968. *Missione archeologica italiana a Malta: Rapporto preliminare della campagna 1967*. Roma: Università di Roma 'La Sapienza'.
- BRUNO, B. 2002. Economia e traffici a Malta in età tardorepubblicana, *L'Africa Romana* XIV: 1063-1072.
- BRUNO, B. 2004. *L'arcipelago maltese in età romana e bizantina: Attività economiche e scambi al centro de mediterraneo*. Bari: Edipuglia.
- BRUNO, B. 2009. *Roman and Byzantine Malta: Trade and Economy*. (trans. G. Cutajar with P.J. Hudson) Malta: Midsea.
- BRUNO, B. and C. CAPELLI 2000. Nuovi tipi di anfore da trasporto a Malta, in C. D'AMICO and C. TAMPPELLINI (eds) *6a Giornata Le scienze della terra e l'archeometria. Este, Museo Nazionale Atestino 26 e 27 febbraio 1999*: 59-65. Este: Grafica Atestina.
- BRUNO, B. and N. CUTAJAR 2013. Imported Amphorae as Indicators of Economic Activity in Early Medieval Malta, in D. MICHAELIDES, P. PERGOLA and E. ZANINI (eds) *The Insular System of the Early Byzantine Mediterranean: Archaeology and History*: 15-29. Oxford: Archaeopress.
- BUSUTTIL, G., M. CAGIANO DE AZEVEDO, A. CIASCA, F. D'ANDRIA, R. DEL MONACO, M.G. GUZZO AMADASI, B. OLIVIERI PUGLIESE, M.P. ROSSIGNANI 1969. *Missione archeologica italiana a Malta: Rapporto preliminare della campagna 1968*. Roma: Università di Roma 'La Sapienza'.
- CAGIANO DE AZEVEDO, M., C. CAPRINO, A. CIASCA, E. COLEIRO, A. DAVICO, G. GARBINI, F.S. MALLIA, G.P. MARCHI, P. MINGANTI, S. MOSCATI, E. PARIBENI, B. PUGLIESE, M.P. ROSSIGNANI, V.S.M. SCRINARI AND A. STENICO 1965. *Missione archeologica italiana a Malta: Rapporto preliminare della campagna 1964*. Roma: Università di Roma 'La Sapienza'.
- CAGIANO DE AZEVEDO, M., C. CAPRINO, A. CIASCA, E. COLEIRO, A. DAVICO, G. GARBINI, F. SAVERIO MALLIA, S. MOSCATI, B. PUGLIESE, M.P. ROSSIGNANI AND A.M. TAMASSIA 1966. *Missione archeologica italiana a Malta: Rapporto preliminare della campagna 1965*. Roma: Università di Roma 'La Sapienza'.
- CAGIANO DE AZEVEDO, M., C. CAPRINO, A. CIASCA, E. COLEIRO, A. DAVICO, G. GARBINI, S. MOSCATI, B. PUGLIESE, M.P. ROSSIGNANI AND A.M. TAMASSIA 1967. *Missione archeologica italiana a Malta: Rapporto preliminare della campagna 1966*. Roma: Università di Roma 'La Sapienza'.
- CAGIANO DE AZEVEDO, M., C. CAPRINO, A. CIASCA, F. D'ANDRIA, A. DAVICO, C. GROTTENELLI, M.G. GUZZO AMADASI, T. MARTINELLI COCO AND M.P. ROSSIGNANI 1972. *Missione archeologica italiana a Malta: Rapporto preliminare della campagna 1969*. Roma: Università di Roma 'La Sapienza'.
- CAGIANO DE AZEVEDO, M., C. CAPRINO, A. CIASCA, F. D'ANDRIA, A. DAVICO, M.G. GUZZO AMADASI AND M.P. ROSSIGNANI 1973. *Missione archeologica italiana a Malta: Rapporto preliminare della campagna 1970*. Roma: Università di Roma 'La Sapienza'.
- CANADAY SPITZER, D. 1942. Roman Relief Bowls from Corinth, *The Journal of the American School of Classical Studies at Athens* 11(2): 162-92.
- CARUANA, A.A. 1881. *Recent discoveries at Notabile: A Memoir*. Malta.
- CARUANA, A.A. 1889. *Ancient Pottery from the Ancient Pagan Tombs and Christian Cemeteries in the Islands of Malta*. Malta: Government Printing Office.
- CASELLI, A. 2013. Revisiting the Roman domus in Rabat, Malta, through a consideration of its mosaic flooring, *Malta Archaeological Review* 9 (2008-2009): 32-39.
- CIASCA, A. 1985a. Note sulla distribuzione di alcune ceramiche puniche maltesi. Il Colloque International sur l'Histoire et l'Archéologie de l'Afrique du Nord (Grenoble, 1983), *Bulletin Archéologique* 19: 1-24.
- CIASCA, A. 1985b. Note sul repertorio ceramic fenicio di occidentale, *Dialoghi di Archeologia* 5(2): 7-12.
- CIASCA, A. 1999. Sicilia e Malta. Note su repertori ceramici a confronto, in A. GONZÁLEZ PRATS (ed.) *La ceràmica fenicia en Occidente: centros de producció y areas de comercio. Actas del I Seminario Internacional sobre Temas Fenicios, Guardamar del Segura, 21-24 de noviembre de 1997*: 69-87. Alicante: Direcció d'Ensenyaments Universitaris I D'Investigació e Instituto de Cultura 'Juan Gil-Albert'.
- CILIA, J. 1984. Museum Esplanade (Melite) 1984 Excavation Notebook, Area 4. Unpublished site notebook. National Museum of Archaeology, Valletta, Malta.
- CULICAN, W. 1982. The Repertoire of Phoenician Pottery, in H.G. NIEMEYER (ed.) *Phönizier im Westen, Die Beiträge des Internationalen Symposiums über 'Die phönizische Expansion im westlichen Mittelmeerraum: in Köln vom 24. bis 27. April 1979*: 45-82. Mainz am Rhein: Verlag Philipp von Zabern.
- CUTAJAR, N. AND M. SPITERI 2014. *Archaeological Evaluation at Tal-Qares, Mosta i.c.w. Rationalisation Scheme Map 27, Site E*. Malta: Superintendence of Cultural Heritage Malta.
- DE MIRO, A. AND A. POLITO 2012. Lucerne in sigillata Africana, ceramica fine e da fuoco dalla necropolis paleocristiana di Lampedusa (Sicilia), *Rei Cretariæ Romanæ Factorvm Acta* 42: 267-72.
- DI GIOVANNI, V. 1996. Produzione e consume di ceramica da cucina nella Campania romana (II a.C.- II d.C.), in M. BATS (ed.) *Les Céramiques Communes de*



- Campanie et de Narbonnaise: La Vaisselle de Cuisine et de Table* (Collection du Centre Jean Bérard 14): 65-103. Naples: Centre Jean Bérard.
- DOCTER, R.F., N.C. VELLA, N. CUTAJAR, A. BONANNO AND A. PACE 2012. Rural Malta: First results of the joint Belgo-Maltese survey project, *BABESCH* 87: 117-57.
- DORE, J.N. 1989. Part II: the coarse pottery, in J. DORE AND N. KEAY (eds) *Excavations at Sabratha 1948-1951, Volume II, The Finds, Part 1: the amphorae, coarse pottery and building materials*: 87-248. London: Society for Libyan Studies.
- DRAP, P., D. MERAD, B. HIJAZI, L. GAOUA, M. NAWAF, M. SACCONI, B. CHEMISKY, J. SEINTURIER, J.-C. SOURISSEAU, T. GAMBIN AND F. CASTRO 2015. Underwater Photogrammetry and Object Modeling: A Case Study of Xlendi Wreck in Malta. *Sensors* 15: 30351-30384.
- DUDLEY BUXTON, L.H. AND A.V.D. HORT 1921. The Modern Pottery Industry in Malta, *Man* 21: 130-31.
- DYSON, S.L. 1976. *Cosa: The Utilitarian Pottery*. (Memoirs of the American Academy in Rome), Volume 33. Michigan: University of Michigan Press.
- ELSTER, E.S., J. LANDER AND M. MOLITOR 1984. The UCLA Mission to Malta. *Archaeology at UCLA* 2(17): [1-4].
- FRANCO, C. 2014. *Sicilian Amphorae (AD I-VI): an economic analysis of production and distribution*. Unpublished D.Phil. dissertation. Oxford: University of Oxford.
- FRENDI, A.J. AND D. MIZZI 2015. The Punic Inscriptions, in A. BONANNO AND N.C. VELLA (eds) *Tas-Silġ, Marsaxlokk (Malta) II: Archaeological Excavations Conducted by the University of Malta 1996-2005*: 515-650. Leuven: Peeters.
- FROST, H. 1969. *The Mortar Wreck in Mellieha Bay. Plans and Soundings: a report on the 1967 campaign carried out on behalf of the National Museum of Malta*. London: Appleton Press.
- FULFORD, M.G. 1984. The coarse (kitchen and domestic) and painted wares, in M.G. FULFORD and D.P.S. PEACOCK (eds) *Excavations at Carthage: The British Mission, volume I, 2. The Avenue di President Habib Bourguiba, Salamambo: The Pottery and Other Ceramic Objects from the Site*: 155-231. Sheffield: The British Academy from the University of Sheffield.
- FULFORD, M.G. 1994. The cooking and domestic pottery, in M.G. FULFORD and D.P.S. PEACOCK (eds) 1994. *Excavations at Carthage, the British Mission. Volume II, 2: The Circular Harbour, North Side: The Pottery*: 53-75. Oxford: Oxford University Press.
- FULFORD, M.G. AND D.P.S. PEACOCK (eds) 1994. *Excavations at Carthage, the British Mission. Volume II, 2: The Circular Harbour, North Side: The Pottery*. Oxford: Oxford University Press.
- FULFORD, M.G. AND J. TIMBY 1994. The fine wares, in M.G. FULFORD AND D.P.S. PEACOCK (eds) *Excavations at Carthage, the British Mission. Volume II, 2: The Circular Harbour, North Side: The Pottery*: 1-21. Oxford: Oxford University Press.
- GAMBIN, T. AND I. WOODS 2017. Into the deep Excavating a Phoenician shipwreck off the coast of Gozo, Malta, *Current World Archaeology* 88.
- GASSNER, V. 2003. *Materielle Kultur und kulturelle Identität in Elea in spätarchaisch-frühklassischer Zeit. Untersuchungen zur Gefäß- und Baukeramik aus der Unterstadt (Grabungen 1987-1994)* (Archäologische Forschungen 8/Velia-Studien 2). Vienna: Verlag Akademie der Wissenschaften.
- HAYES, J.W. 1972. *Late Roman Pottery*. London: The British School at Rome.
- HAYES, J.W. 1976. Pottery: Stratified Groups and Typology, in J.H. HUMPHREY (ed.) *Excavations at Carthage 1975 conducted by the University of Michigan, vol. 1*: 47-108. Tunis: Institut National d'Archéologie et d'Art; American Schools of Oriental Research.
- HAYES, J.W. 1980. *A Supplement to Late Roman Pottery*. London: The British School at Rome.
- HAYES, J. W. 1983. The Villa Dionysos Excavations, Knossos: The Pottery, *The Annual of the British School at Athens* 78: 97-169.
- HAYES, J.W. 2008. *Roman Pottery: Fine-Ware Imports. The Athenian Agora, Volume 32*. Princeton: The American School of Classical Studies at Athens.
- HENDERSON, J. 2000. *The Science and Archaeology of Materials: An Investigation of Inorganic Materials*. London: Routledge.
- KEAY, S. 1984. *Late Roman Amphorae in the Western Mediterranean: A Typology and Economic Study: The Catalan Evidence*. Part 1. Oxford: BAR.
- KEAY, S. AND D. WILLIAMS 2005 [2014]. *Roman Amphorae: a digital resource*. University of Southampton [data-set] York: Archaeology Data Service ([http://archaeologydataservice.ac.uk/archives/view/amphora\\_ahrb\\_2005/?CFID=5381493andCFTOKEN=10796190](http://archaeologydataservice.ac.uk/archives/view/amphora_ahrb_2005/?CFID=5381493andCFTOKEN=10796190)), last accessed: 25 September 2015.
- KENRICK, P.M. 1985. *Excavations at Sidi Khrebish, Benghazi (Berenice), Volume III, Part 1: The Fine Pottery* (Supplements to Libya Antiqua V). Tripoli.
- KENRICK, P.M. 1987. 'Tripolitanian sigillata': A response, *Libyan Studies* 18: 88.
- KÖGLER, P. 2014. Table Ware from Knidos: The Local Production during the second and first centuries BC, in P. GULDAGER BILDE AND M.L. LAWALL (eds) *Pottery, Peoples and Places: Study and Interpretation of Late Hellenistic Pottery*: 157-73. Aarhus: Aarhus University Press.
- LANDER, J. 1983. The Melita Excavations, 1983: Excavation Report (Rough Draft). Unpublished typescript.
- LANDER, J. 1984. A Report on the 1984 Season of Excavation at Melita, the Ancient Capital of Malta. Submitted to Prof. Merrick Posnansky, Director, Institute of Archaeology, UCLA. Unpublished typescript.

- LAUBENHEIMER, F. 2013. Amphoras and Shipwrecks: Wine from the Tyrrhenian Coast at the End of the Republic and Its Distribution in Gaul, in J. DEROSE EVANS (ed.) *A Companion to the Archaeology of the Roman Republic*: 97-109. Oxford: Wiley-Blackwell.
- LEITCH, V. 2010. Production and Trade of Roman and Late Roman African Cookwares. Unpublished D.Phil. dissertation. Oxford: University of Oxford.
- LEITCH, V. 2013. Reconstructing history through pottery: the contribution of Roman N. African cookwares, *Journal of Roman Archaeology* 26: 281-306.
- LUTTRELL, A. 1975. Approaches to Medieval Malta, in A. LUTTRELL (ed.) *Medieval Malta, Studies on Malta before the Knights*: 1-70. London: The British School at Rome.
- MALFITANA, D. 2005. 'Corinthian' Roman Relief Ware: new studies and preliminary results, in M.B. Briese and L.E. Vaag (eds) *Trade Reation in the Eastern Mediterranean from the Late Hellenistic Period to Late Antiquity: The Ceramic Evidence*: 83-97. Odense: University Press of Southern Denmark.
- MALFITANA, D. 2007. *La Ceramica Corinza Decorata a Relievo. Tipologia, Cronologia ed Iconografia di una Classe Ceramica Greca di Età Imperiale. Rei Cretariae Fautorum*, Supp. 10. Bonn: Habelt.
- MARABINI MOEVS, M.T. 1973. *The Roman Thin Walled Ware from Cosa (1948-1954)*. Michigan: University of Michigan Press.
- MARAOUI TELMINI, B. 2009. *Les vases-biberons puniques du bassin occidental de la Méditerranée: Monographie d'une forme*. Manouba: Centre de Publication Universitaire.
- MARKOULAKI, S., J.-Y. EMPEREUR AND A. MARANGOU 1989. Recherches sur les centres fabrication d'amphores de Crète occidentale, *Bulletin de Correspondance Hellénique* 113(2): 551-80.
- MARTIN-KILCHER, S. 1999. Karthago 1993. Die Füllung eines frühkaiserzeitlichen Pozzo, in F. RAKOB (ed.) *Karthago III. Die deutschen Ausgrabungen in Karthago*: 404-34. Mainz am Rhein: P. von Zabern.
- MOLINER, M. 1996. Les céramiques communes à Marseille d'après les fouilles récentes, in M. BATS (ed.) *Les Céramiques Communes de Campanie et de Narbonnaise: La Vaisselle de Cuisine et de Table* (Collection du Centre Jean Bérard 14): 237-55. Naples: Centre Jean Bérard.
- MOLITOR, M. 1988. *Pots and Potters of Prehistoric Malta*. Unpublished PhD dissertation. Los Angeles: University of California.
- MOMMSEN, H., A. BONANNO, K. CHETCUTI BONAVIDA, I. KAKOULLI, M. MUSUMECI, C. SAGONA, A. SCHWEDT, N.C. VELLA AND N. ZACHARIAS 2006. Characterisation of Maltese pottery of the Late Neolithic, Bronze Age and Punic Period by neutron activation analysis, in M. MAGGETTI AND B. MESSIGA (eds) *Geomaterials in Cultural Heritage* 157: 81-89. London: Geological Society.
- MOREL, J.P. 1994. *Céramique campanienne: les formes*. Second edn. Rome: École française de Rome.
- NAPOLITANI, S. 2007. La ceramica sigillata nella collezione del National Museum of Archaeology di Malta. Unpublished dissertation. Rome: Università di Roma, 'La Sapienza'.
- OLCESE, G. 1993. *Le ceramiche comuni di Albintimilium. Indagine archeologica e archeometrica sui materiali dell'area del Cardine*. Firenze: All'Insegna del Giglio.
- OPAIȚ, A. 2007. From Dr 24 to LRA 1?, in M. BONIFAY and J.-C. TRÉGLIA (eds) *Late Roman Coarse Wares, Cooking Wares and Amphorae in the Mediterranean: Archaeology and Archaeometry*, Vol. 2: 627-43. Oxford: Archaeopress.
- PACE, A., N. CUTAJAR, B. MERCIĘCA SPITERI, C. MIFSUD AND M. SPITERI 2012. The Żejtun villa and its ancient landscape - three new archaeological discoveries in, R. ABELA (ed.) *The Żejtun Roman Villa: Research, Conservation, Management*: 60-73. Malta: Wirt iz-Żejtun.
- PANELLA, C. 1968. Anfore, in *Le Terme del Nuotatore, scavo dell'ambiente IV* (Studi Miscellanei 13) *Ostia I*: 97-135.
- PANELLA, C. 1973. Appunti su un gruppo di anfore della prima, media e tarda età imperial (secoli I-V d.c.), in *Le Terme del Nuotatore, scavo dell'ambiente IV* (Studi Miscellanei 21) *Ostia III*: 460-696.
- PASSELAC, M. 1993a. Céramique sigillée italique, in M. PY, A.M. ADROHER AND C. RAYNAUD (eds) *Dicocer: dictionnaire des céramiques antiques (VIIème s.av.n.è. - VIIème s.de.n.è.) en Méditerranée nord-occidentale* (Provence, Languedoc, Ampurdan): 554-68. Caveirac: Association pour la recherche archéologique en Languedoc oriental.
- PASSELAC, M. 1993b. Céramique à vernis rouge pompéien, in M. PY, A.M. ADROHER AND C. RAYNAUD (eds) *Dicocer: dictionnaire des céramiques antiques (VIIème s.av.n.è. - VIIème s.de.n.è.) en Méditerranée nord-occidentale* (Provence, Languedoc, Ampurdan): 545-47. Caveirac: Association pour la recherche archéologique en Languedoc oriental.
- PEACOCK, D.P.S. 1977. *Pottery and Early Commerce: Characterisation and trade in Roman and later ceramics*. London: Academic Press.
- PEACOCK, D.P.S. 1982. *Pottery in the Roman world: an ethnoarchaeological approach*. London: Longman.
- PEACOCK, D.P.S. 1984a. Petrology and Origins, in M.G. FULFORD AND D.P.S. PEACOCK (eds) *Excavations at Carthage: The British Mission, volume 1, 2. The Avenue du President Habib Bourguiba, Salamambo: The Pottery and Other Ceramic Objects from the Site*: 6-28. Sheffield: The British Academy from the University of Sheffield.
- PEACOCK, D.P.S. 1984b. Appendix 1: Seawater, Salt and Ceramics, in M.G. FULFORD AND D.P.S. PEACOCK (eds) *Excavations at Carthage: The British Mission, volume 1, 2. The Avenue du President Habib Bourguiba, Salamambo: The Pottery and Other Ceramic Objects from the Site*: 263-64. Sheffield: The British Academy from the University of Sheffield.

- PEACOCK, D.P.S. AND D.F. WILLIAMS 1986. *Amphorae and the Roman economy: An introductory guide*. London: Longman.
- PEDLEY, M. AND M. HUGHES CLARKE 2002. *Limestone Isles in a Crystal Sea: The Geology of the Maltese Islands*. Malta: PEG.
- PERASSI, C. 2013. Numismatica insulare. Monete delle zecche di Melita e di Gaulos nella Collezione Nazionale Maltese, *Rivista Italiana di Numismatica e Scienze Affini* 114: 15-52.
- POLIZZI C. 1997. Anfore greche da trasporto, in C. GRECO, F. SPATAFORA AND S. VASALLO (eds) *Archeologia e territorio*: 95-103. Palermo: Beni Culturali Palermo/Palumbo editore.
- PY, M. 1993a. Céramique campanienne A, in M. PY, A.M. ADROHER AND C. RAYNAUD (eds) *Dicocer: dictionnaire des céramiques antiques (VIIème s.av.n.è.-VIIème s.de.n.è.) en Méditerranée nord-occidentale (Provence, Languedoc, Ampurdan)*: 146-50. Caveirac: Association pour la recherche archéologique en Languedoc oriental.
- PY, M. 1993b. Céramique campanienne C, in M. PY, A.M. ADROHER AND C. RAYNAUD (eds) *Dicocer: dictionnaire des céramiques antiques (VIIème s.av.n.è.-VIIème s.de.n.è.) en Méditerranée nord-occidentale (Provence, Languedoc, Ampurdan)*: 153-54. Caveirac: Association pour la recherche archéologique en Languedoc oriental.
- QUERCIA, A. 2000. Pasti rituali nella Malta Punica, *Malta Archaeological Review* 4: 28-33.
- QUERCIA, A. 2002. La ceramica da fuoco del santuario di Tas-Silġ (Malta): tipi attestati e proposte interpretative, in M.G. AMADASI GUZZO, M. LIVERANI AND P. MATTHAIE (eds) *Da Pyrgi a Mozia. Scritti sull'archeologia del Mediterraneo: studi in memoria di Antonia Ciasca*: 403-24. Roma: Università di Roma 'La Sapienza'.
- QUERCIA, A. 2004-2005. La ceramica punico-maltese del santuario di Tas-Silġ: analisi tipologica e funzionale, *Scienze dell'Antichità: Storia archeologia antropologia* 12: 335-54.
- QUERCIA, A. 2006. Rapporti e contatti tra isole del Mediterraneo centrale: la Pantellerian Ware a Malta, *L'Africa Romana* XVI: 1597-614.
- QUERCIA, A. 2011. Typological and morphological remarks upon some vessels in the repertoire of pottery in Punic Malta, in C. SAGONA (ed.) *Ceramics of the Phoenician-Punic World: Collected Essays*: 433-50. Leuven: Peeters.
- QUERCIA, A. AND M. ANASTASI 2008-2009. Għar ix-Xiħ (Gozo), Scavo 2005. Relazione preliminare sulla ceramica. Unpublished typescript.
- RAMON, J. 1995. *Las ánforas fenicio-púnicas del Mediterráneo central y occidental*. Barcelona: Consell Insular d'Eivissa i Formentera, Conselleria de Cultura, Educació i Patrimoni: Universitat de Barcelona.
- REYNOLDS, P. 1997. Appendix 1b. Ceramic studies: A first century AD pottery assemblage from Lepcis Magna, in H. WALDA AND K. WILKINSON WITH S.A. ASHTON, P. REYNOLDS, J. SIDELL AND I. WELSBY SJÖSTRÖM. The 1996 Excavations at Lepcis Magna: 49-63, *Libyan Studies* 28: 43-70.
- RICE, P.M. 1987. *Pottery Analysis: A Sourcebook*. Chicago: University of Chicago Press.
- RILEY, J.A. 1979. The coarse pottery from Berenice, in J.A. LLOYD (ed.) *Excavations at Sidi Khrebish, Benghazi (Berenice), Volume II*. (Supplements to Libya Antiqua V): 91-497. Tripoli.
- ROBINSON, H.S. 1959. *The Athenian Agora. Pottery of the Roman Period: Chronology V*. New Jersey: Princeton University: The American School of Classical Studies at Athens.
- ROTROFF, S.I. 2006. *The Athenian Agora, Volume XXXIII. Hellenistic Pottery: The Plain Wares*. New Jersey: Princeton University: The American School of Classical Studies at Athens.
- SAGONA, C. 2002. *The Archaeology of Punic Malta*. Leuven: Peeters.
- SAGONA, C. 2015. The Pottery, in A. BONANNO AND N.C. VELLA (eds) *Tas-Silġ, Marsaxlokk (Malta) II: Archaeological Excavations Conducted by the University of Malta, 1996-2005*: 1-513. Leuven: Peeters.
- SANTORO, S. 2007. Le ceramiche da cucina prodotte in Italia ed esportate nel Mediterraneo: un primo panorama archeometrico ed archeologico sulla base di una banca dati, in M. BONIFAY AND J.-C. TRÉGLIA (eds) *LRCW 2 Late Roman Coarse Wares, Cooking Wares and Amphorae in the Mediterranean: Archaeology and Archaeometry*: 365-77. Oxford: Archaeopress.
- SAUSMEKAT, M. 2016. *Archaeology and Politics in Post-Independence Malta*. Unpublished B.A. (Hons) Dissertation. Malta: University of Malta.
- SCATOZZA HÖRICH, L.A. 1996. Appunti sulla ceramica comune di Ercolano. Vassellame da cucina e recipienti per la preparazione degli alimenti, in M. BATS (ed.) *Les Céramiques Communes de Campanie et de Narbonnaise: La Vaisselle de Cuisine et de Table (Collection du Centre Jean Bérard 14)*: 129-56. Naples: Centre Jean Bérard.
- SCHMIDT, K. AND B. BECHTOLD 2013. Fabrics of Malta, in *FACEM* (version 06/12/2013) (<http://www.facem.at/project-papers.php>).
- SCOTT, D. 1962. *Excavations at Ras ir-Raħeb (1961-1962)*. Unpublished typescript, National Museum of Archaeology, Malta.
- SORICELLI, G. 1987. 'Tripolitanian Sigillata': North African or Campanian? *Libyan Studies* 18: 73-88.
- STONE, S.C. 2014. *The Hellenistic and Roman Fine Pottery (Morgantina Studies Vol. VI)*. New Jersey: Princeton University.
- TECHER, I., L. CASTELEYN, M. ROCHER, Y. MISSENERD, P. ROBION AND J. REYNES 2013. Identifying Eroded Messinian Deposits on the Maltese Islands by

- Gypsum Sr Isotopes, *Procedia Earth and Planetary Science* 7: 830-33.
- VELLA, N.C., A. BONANNO, M. ANASTASI, B. BECHTOLD, R. FARRUGIA, K. FENECH, D. MIZZI, L. VERDONCK AND A. ZAMMIT 2017. A view from the countryside: the nature of the Late Punic and Early Roman activity at the Żejtun villa site, Malta, *Rivista di Studi Fenici* XLV: 109-227.
- VEGAS, M. 1999. Phönoko-punische Keramik aus Karthago, in F. RAKOB (ed.) *Karthago III. Die deutschen Ausgrabungen in Karthago*: 47-108. Mainz am Rhein: P. von Zabern.
- VIDAL GONZÁLEZ, P. 1996. *La Isla de Malta en Época Fenicia y Púnica*. Oxford: Archaeopress.
- WILL, E.L. 1982. Greco-Italic amphoras, *Hesperia* 51(3): 338-56.
- WILSON, A. 2012. Approaches to quantifying Roman trade, in A. BOWMAN AND A. WILSON (eds) *Quantifying the Roman Economy: Methods and Problems*: 213-249. Oxford: Oxford University Press.
- ZAMMIT, M. 1984. Museum Esplanade (Melite) 1984 Excavation Notebook, Area 6. Unpublished site notebook. National Museum of Archaeology, Valletta, Malta.
- ZAMMIT, T. 1922. Excavations in Malta, *Antiquaries Journal* 2: 131-34.
- ZAMMIT, T. 1923. Excavations at Rabat, Malta, *Antiquaries Journal* 3: 219-25.
- ZAMMIT, V. 1984. Museum Esplanade (Melite) 1984 Excavation Notebook, Area 5. Unpublished site notebook. National Museum of Archaeology, Valletta, Malta.

Much of what is known about Malta's ancient material culture has come to light as a result of antiquarian research or early archaeological work – a time where little attention was paid to stratigraphic context. This situation has in part contributed to the problem of reliably sourcing and dating Maltese Roman-period pottery, particularly locally produced forms common on nearly all ancient Maltese sites. *Pottery from Roman Malta* presents a comprehensive study of Maltese pottery forms from key stratified deposits spanning the first century BC to mid-fourth century AD. Ceramic material from three Maltese sites was analysed and quantified in a bid to understand Maltese pottery production during the Roman period, and trace the type and volume of ceramic-borne goods that were circulating the central Mediterranean during the period. A short review of the islands' recent literature on Roman pottery is discussed, followed by a detailed contextual summary of the archaeological contexts presented in this study. The work is supplemented by a detailed illustrated catalogue of all the forms identified within the assemblages, presenting the wide range of locally produced and imported pottery types typical of the Maltese Roman period.

*Maxine Anastasi* is a Lecturer at the Department of Classics and Archaeology, University of Malta. She was awarded a DPhil in Archaeology from the University of Oxford for her dissertation on small-island economies in the Central Mediterranean. Her research primarily focuses on Roman pottery in the central Mediterranean, with a particular emphasis on Maltese assemblages. She has participated in a number of the University of Malta's past excavation projects in Malta and Gozo, including the Tas-Silġ Excavation Project and the Għar ix-Xih Excavation Project, and supervises the University's current training excavations at the Żejtun Roman villa and the Tas-Silġ sanctuary. She is currently studying a number of pottery assemblages from Malta and from recent archaeological projects in Utica (Tunisia) and Pantelleria.

