



L-Università
ta' Malta

MATRICULATION AND SECONDARY EDUCATION CERTIFICATE
EXAMINATIONS BOARD

**ADVANCED MATRICULATION LEVEL
2020 SECOND SESSION**

SUBJECT: **Biology**
 PAPER NUMBER: I
 DATE: 14th December 2020
 TIME: 4.00 p.m. to 7:05 p.m.

Directions to Candidates

- Write your index number in the space at the top left-hand corner of this page.
 - Answer **ALL** questions. Write all your answers in the spaces provided in this booklet.
 - The mark allocation is indicated at the end of each question. Marks allocated to parts of questions are also indicated.
 - You are reminded of the necessity for good English and orderly presentation in your answers.
 - In calculations you are advised to show all the steps in your working, giving your answer at each stage.
 - The use of electronic calculators is permitted.
-

For examiners' use only:

Question	1	2	3	4	5	6	7	8	9	10	Total
Score											
Maximum	6	9	8	10	15	15	10	10	9	8	100

1. This question concerns the cell.

Figure 1 shows three diagrammatic representations of the process which results in particles entering the cell.

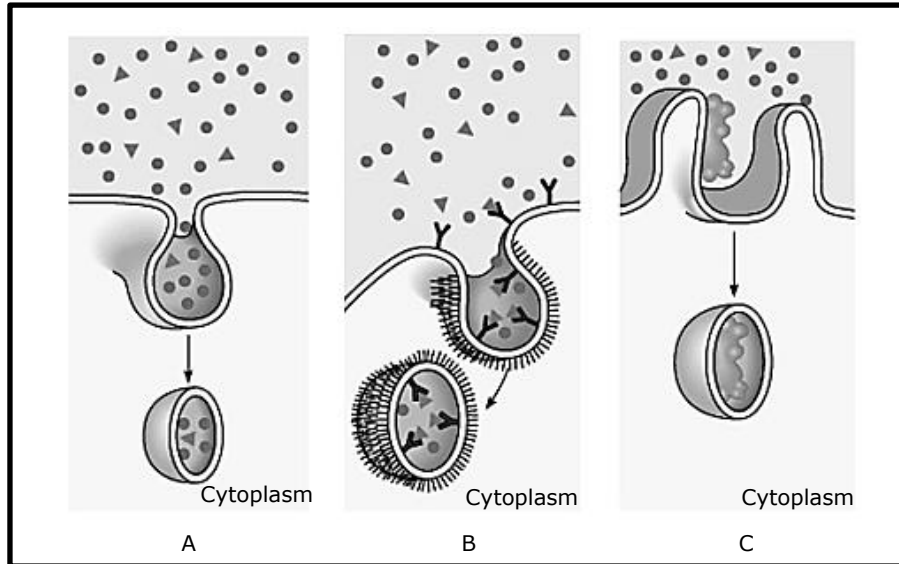

Figure 1: Diagrammatic representation of the process which results in particles entering the cell. (Adapted from: www.slideshare.com)

a. Name the general process illustrated in Figure 1.

_____ (1)

b. Name the **THREE** types of the process mentioned as an answer to part (a) as represented by the letters A, B and C in Figure 1.

A. _____ (1)

B. _____ (1)

C. _____ (1)

c. Give **TWO** features that prokaryotic and eukaryotic cells have in common.

_____ (2)

(Total: 6 marks)

2. This question concerns mitosis and meiosis.

- a. Complete the table below by ticking the correct box to indicate the presence of a process occurring during the period of nuclear division indicated. Some processes may occur during one or more periods.

Table 1: Processes that occur during the period of nuclear division.

Process	Mitosis	Meiosis I	Meiosis II
Synapsis			
Replication of DNA			
Separation of homologous chromosome			
Anaphase			

(4)

b. Fill in the blanks with the most appropriate word.

- i. In mitosis, all chromosomes become aligned at the spindle equator at the end of _____, and the sister chromosomes are pulled to opposite poles of the cell during _____.
- (1)
- ii. The _____ is the region of the chromosome to which the microtubules of the spindle attach, via the kinetochore, during cell division.
- (½)
- iii. Cytoplasm division, called _____, is accompanied in animal cells by the formation of a depression around the midsection, called a _____, and in plant cells by the formation of a disc-like layer of vesicles, at the spindle equator, whose contents produce the _____.
- (1½)

c. i. Give **ONE** reason why mitosis is important.

_____ (1)

ii. Give **ONE** reason why meiosis is important.

_____ (1)

(Total: 9 marks)
Please turn the page.

3. This question is about genetics.

In birds, the females are XY whilst the males are XX.

a. Explain why it is more common to find recessive, sex-linked characteristics in female birds than in male birds.

_____ (1)

b. The rate of feather production in chickens is controlled by a gene found on the X chromosome. The allele for slow feather production (F) is dominant to the allele for rapid feather production (f).

i. The offspring produced when two chickens were crossed were as follows:

- two females which had slow feather production;
- two males which had rapid feather production.

Give the genotypes of the parents.

_____ (2)

Figure 2 shows a pedigree chart showing the inheritance of the rate of feather production in chicken.

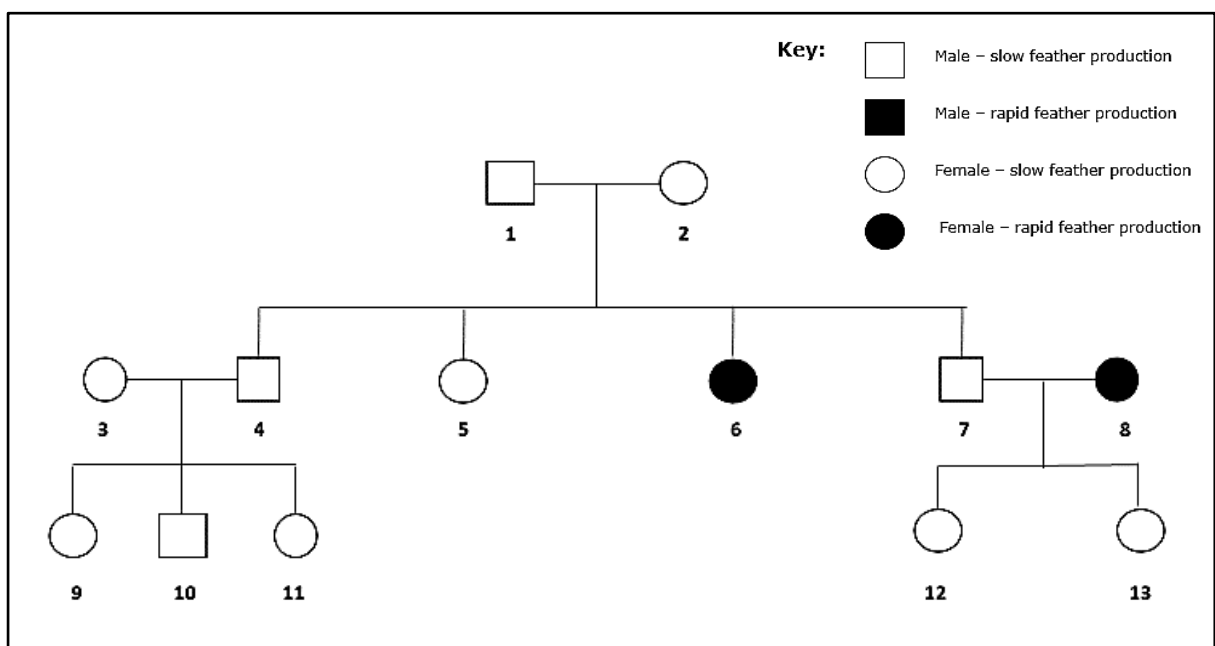

Figure 2: Pedigree chart showing the inheritance of the rate of feather production in chicken.

ii. Give all the possible genotypes of the following chickens:

Chicken 2: _____ (1)

Chicken 4: _____ (1)

Chicken 6: _____ (1)

iii. With reference to Figure 2, explain **ONE** piece of evidence that indicates that the allele for rapid feather production is recessive.

_____ (2)

(Total: 8 marks)

4. This question is about nutrition.

a. Identify and define the mode of nutrition in the following scenarios:

i. *Halicephalobus mephisto*, also known as devil worm, is a nematode that is millions of times bigger than the bacteria it feeds on.

_____ (2)

ii. Some organisms are able to survive by fixing carbon dioxide, others fix sulfur, and others, such as the bacterium *Acidithiobacillus ferrooxidans*, is able to survive in acidic conditions and fixes iron.

_____ (2)

This question continues on next page.

- b. The rate of photosynthesis, just like any other biochemical process, involves a series of reactions and will theoretically be limited by the slowest reaction in the series. Figure 3 shows the effect of two factors on the rate of photosynthesis.

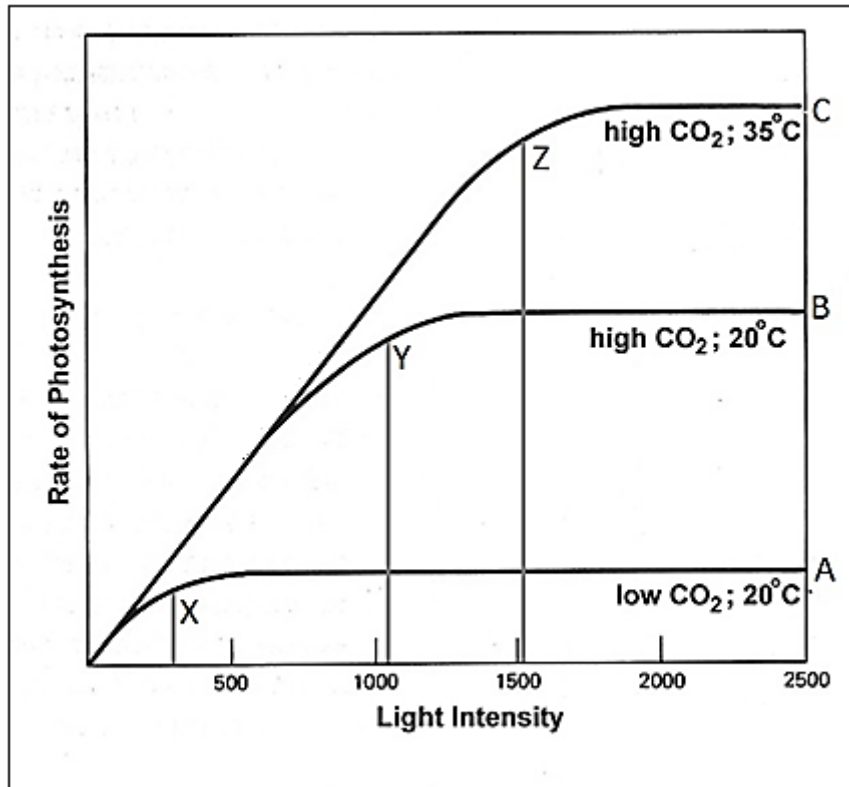

Figure 3: Factors affecting the rate of photosynthesis.
 (Adapted from: <http://faculty.collin.edu>)

- i. Explain the differences in graphs A, B and C.

_____ (3)

- ii. What are the implications on enzymes when temperature increases from point B to point C?

_____ (2)

- iii. What do points X, Y and Z represent on the curves?

_____ (1)

(Total: 10 marks)

5. This question is about transport in animals.

a. What type of muscle is the heart made up of?

_____ (1)

b. The cardiac cycle refers to the events that take place between one heartbeat and the next. Briefly outline the principal events that take place during the cardiac cycle.

 _____ (3)

c. Table 2 lists some factors that affect the human heart rate. Complete the table by indicating whether the heart rate increases, decreases, or remains the same in response to the factors listed.

Table 2: Factors that affect the heart rate and their effect.

Factor	Effect on heart rate (increase/ decrease/ no effect)
High body temperature	
High adrenaline concentration in the blood	
High blood pressure in all major arteries	
Low oxygen concentration in the blood	

(2)

This question continues on next page.

d. Give **ONE** difference between an open circulatory system and a closed circulatory system?

_____ (1)

e. Mention **TWO** advantages of a closed circulatory system over an open circulatory system.

Advantage 1: _____

_____ (1)

Advantage 2: _____

_____ (1)

f. How is a single circulatory system different from a double circulatory system?

_____ (1)

g. Mention **TWO** advantages of a double circulatory system over a single circulatory system.

Advantage 1: _____

_____ (1)

Advantage 2: _____

_____ (1)

h. The following questions concern the ventricles.

i. How is the blood in the left ventricle different from that in the right ventricle?

_____ (1)

ii. What advantages will an increase in the cavity size and wall thickness in the left ventricle provide?

_____ (2)

(Total: 15 marks)

6. This question is about respiration.

Fick's law of diffusion provides a way of considering how the maximum rate of diffusion of respiratory gases can be achieved.

a. Which **FOUR** physical factors are considered in Fick's law of diffusion?

(2)

b. Briefly explain how the following features of a respiratory surface improve the rate of diffusion.

i. It must be permeable.

(1)

ii. It should possess a good blood supply.

(1)

iii. It must be moist.

(1)

c. Using **TWO** similarities and **TWO** differences, explain how the lungs found in mammals and the gills found in fish differ from one another yet are both adapted for gaseous exchange.

(4)

This question continues on next page.

d. Insects have developed a gaseous exchange mechanism which is facilitated by the tracheae. How do tracheae facilitate gaseous exchange?

(4)

e. Indicate whether the following statements are True or False.

i. Haemoglobin can carry both oxygen and carbon dioxide at the same time.

(½)

ii. Haemoglobin loads or unloads oxygen independent of the surrounding oxygen concentration.

(½)

iii. Oxygen and carbon dioxide compete for the same binding site on the haemoglobin molecule.

(½)

iv. Blood loads or unloads carbon dioxide depending upon the surrounding carbon dioxide concentration.

(½)

(Total: 15 marks)

7. This question is about gametogenesis in plants.

Figure 4 is a diagram showing the product of megagametogenesis of Magnoliophyta.

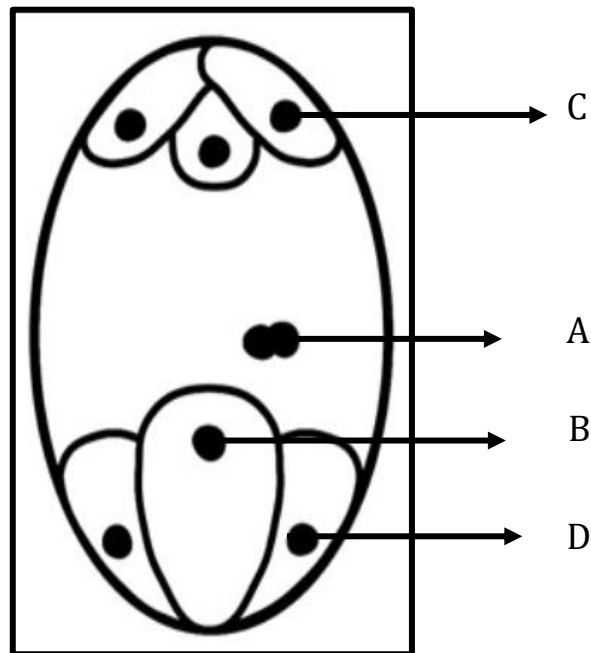

Figure 4: Megagametogenesis in Magnoliophytes
(Adapted from *plantcell.org*)

a. Where within the female reproductive organ would such gametophyte be found?

_____ (1)

b. What is the name given to the mature female gametophyte?

_____ (1)

c. Give the name of the parts labelled A-D present within the mature gametophyte.

i. A: _____ (½)

ii. B: _____ (½)

iii. C: _____ (½)

iv. D: _____ (½)

This question continues on next page.

d. Explain why structure A is pivotal for terrestrial colonization.

(2)

e. Briefly explain the importance of the following during fertilisation:

i. the generative nucleus

(2)

ii. the tube nucleus

(2)

(Total: 10 marks)

8. This question is about propagation and transmission of nerve impulses.

Myelination is important for transmission of electrical impulses. The following graph (Figure 5) attests for the benefit of myelination. Myelin, along with Nodes of Ranvier, allow propagation of nerve impulses through saltatory conduction.

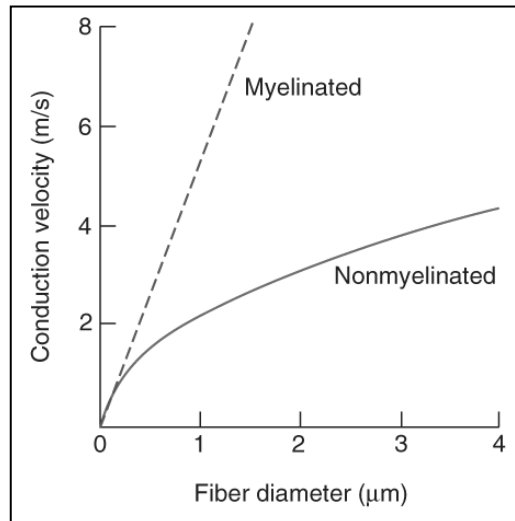

Figure 5: Difference in velocity between myelinated and nonmyelinated axons
 (Adapted from <https://neupsykey.com/signaling-in-the-nervous-system/>)

a. From the graph (Figure 5), state the benefit of myelination.

_____ (1)

b. Briefly explain the following observations.

i. Propagation of action potentials occurs quicker during a fight or flight response.

 _____ (2)

ii. Thin axon diameters slow down propagation.

 _____ (2)

iii. Lack of Nodes of Ranvier slow down propagation.

 _____ (2)

This question continues on next page.

c. Myelination is also exhibited within the spinal cord and the brain. Two types of matter can be found: unmyelinated matter and myelinated one.

i. What is the unmyelinated matter called?

_____ (1)

ii. Why should such matter be devoid of myelin for effective synapse to occur?

 _____ (2)

(Total: 10 marks)

9. This question is about homeostasis of glucose levels.

The following graph (Figure 6) shows the blood glucose levels of a healthy (normal) person and a diabetic patient. The dotted line shows the glucose level value of a person when at rest.

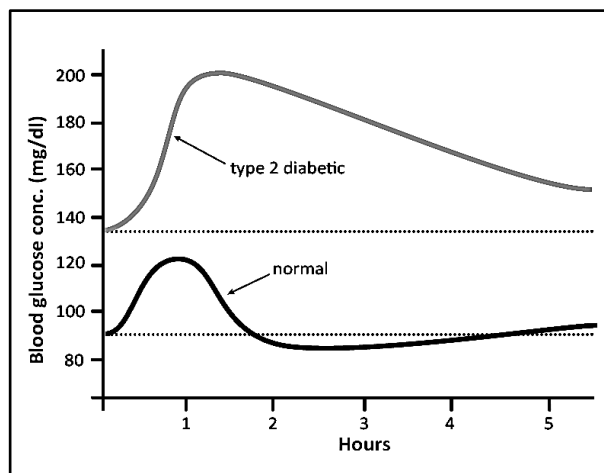

Figure 6: Graph showing the difference in glucose levels in two different persons. (Adapted from: <https://themedicalbiochemistrypage.org/diabetes.php>)

a. Differentiate between Type 1 and Type 2 diabetes.

 _____ (2)

b. Is the diabetic patient prone to suffer from hypoglycaemia or hyperglycaemia? Give a reason for your answer.

 _____ (2)

c. Which hormone is produced by the pancreas when blood glucose levels are high?

_____ (1)

d. Which **TWO** processes would the hormone mentioned as an answer to part (c) instigate the liver to perform?

_____ (1)

e. Which hormone would be produced in the normal person from the second hour to the fourth (Figure 6)?

_____ (1)

f. List **TWO** ways how the hormone mentioned as an answer to part (e) causes a negative feedback response to maintain glucose homeostasis.

_____ (2)

(Total: 9 marks)

Please turn the page.

10. This question is about tissue that provide support in plants.

a. Do parenchyma cells offer support when flaccid? Give a reason for your answer.

(2)

b. Which support tissue/s is/are absent in hydrophytes? Give a reason for your answer.

(2)

c. Why should collenchyma cells be found at the periphery of stems and not at the core?

(2)

d. Explain why tracheids, unlike vessel members, are found in all vascular plants.

(2)

(Total: 8 marks)



SUBJECT:	Biology
PAPER NUMBER:	II
DATE:	15 th December 2020
TIME:	4:00 p.m. to 7:05 p.m.

Directions to Candidates

- Answer the question in Section A, any **TWO** questions from Section B and **ONE** question from Section C. Write all your answers in the separate booklet provided.
 - If more than two questions from Section B are attempted, only the first two answers shall be taken into consideration.
 - If more than one question from Section C is attempted, only the first answer shall be taken into consideration.
 - The mark allocation is indicated at the end of each question. Marks allocated to parts of questions are also indicated.
 - You are reminded of the necessity for good English and orderly presentation in your answers.
 - In calculations you are advised to show all the steps in your working, giving your answer at each stage.
 - The use of electronic calculators is permitted.
-

SECTION A**This section is obligatory**

1. Read carefully the following extract. Then using the information provided and your knowledge of biology, answer the questions that follow. The numerals in the left-hand margin are the line numbers.

Adapting to the environment better than Love Island

Evolution of species on islands has long been seen as the perfect standpoint to elicit the pathways and tendencies that encompass the passage of advantageous phenotypic traits. Research on the Galapagos islands is evidence of this. The formation of islands has lead organisms that were presently on them to adapt fast to the new abiotic stresses. Islands are geographical areas that were once part of a major continent and, therefore, once formed, would exhibit new abiotic stresses from their original mainland. Islands may also be formed through volcanic activity and on such, pioneer species are pivotal to the ecological succession occurring which inadvertently influences the evolutionary pathways organisms would assume.

Darwin's observations, specifically on what are now called "Darwin's finches" explain how through adaptive radiation, new morphological adaptations arose due to the various different abiotic and biotic stresses that each island posed. This happens infrequently and suddenly. In most populations, the number of species is larger than the availability of resources which leads to competition and this is very much applicable to islands. Adaptations are then said to be contingent to the degree of niche overlap exhibited on islands.

Adaptation to new stressors can be achieved through a change in the genetic make-up of the organisms or a modification of its behaviour. Within the normal variation that occurs in species, occasionally a mutation or difference will occur that will be somehow advantageous to survival and breeding. Those best adapted to their environment, most specified and adaptive, will survive. After years of isolation on the Galapagos, where small populations of a species must have existed, adaptations within that species would be more drastic as there was no large mainstream population to act as a buffer for variations. These new adaptations would be quite pronounced, with certain featured being more advantageous than others.

This divergence from ancestral adaptations was also exhibited right here in Malta in events that occurred around 2,588,000 to 12,000 years ago when Malta became an island. An example of this is the case of the pygmy hippopotamus that inhabited the Maltese islands during the Pleistocene era. Long separated from its mainland ancestors, these animals evolved unique traits. Through several adaptations, they became one third the size of their ancestors. Considering that hippos need good access to water bodies to support their weight, the reduction in body size was necessary.

Known as *Hippopotamus melitensis*, they stood only 80 cm high whereas *Hippopotamus amphibious*, its believed ancestor, exhibits a median height of 150 cm. Plagued by the incidence of insular dwarfism, evolution of a smaller species due to land restriction, has made them unique. More than 90% of the mammalian fossils from Ghar Dalam indicate that the hippopotamus species also exhibited different dentition. *Hippopotamus melitensis*, exhibited lophodont dentition which its ancestor does not.

(Adapted from: Quaternary Environments and Biogeography of the Maltese Islands)

- a. In line 7, the term pioneer species is used. Define pioneer species and briefly explain their importance in ecological succession. (2)
- b. Islands are particularly affected by a certain type of isolating mechanisms. Name this mechanism and briefly explain what type of speciation this leads to. (3)
- c. Which genetic drift is exhibited once islands detach from mainland? Give a reason for your answer. (2)
- d. Which mode of equilibrium is mostly exhibited on island species? Support your answer from the text. (3)
- e. How do mainstream populations act as buffers for variations as implied in line 21? (2)
- f. What kind of natural selection mechanisms was influencing the evolution of *Hippopotamus melitensis*? Give a reason for your answer. (2)
- g. List **THREE** natural selection pressures that influence the evolution of organisms living on relatively small islands such as the Maltese islands. (3)
- h. The species *Hippopotamus melitensis* exhibits different morphological features from its ancestors. Why is small size preferred over large size when it comes to inhabiting warm climate islands such as the Maltese islands? (3)
- i. Dentition was also a distinguishing feature between both species of *Hippopotamus*. What does this suggest in terms of food acquisition? (2)
- j. "Those best adapted to their environment, most specified and adaptive, will survive" (lines 18-19). Which ecological principle drives natural selection? Give a brief explanation how such principle influences evolution. (3)

(Total: 25 marks)

SECTION B

Answer any TWO questions from this section; your answers should take the form of essays. Each question carries twenty-five marks.

1. Give an account of the structure and replication of deoxyribonucleic acid (DNA).
2. Describe in detail the interactions among organisms within and between overlapping niches.
3. Most animals need to maintain their core body temperature within a relatively narrow range. Discuss the mechanisms required to maintain this body temperature.
4. Gene technology revolutionised the forensic, pharmaceutical, medical, and agricultural industry. Elaborate on this statement by making reference to **FOUR** gene technology applications.

(Total: 50 marks)

Please turn the page.

SECTION C

Answer ONE question from this section.

1. Write brief notes on the following:

- a. cephalisation; (5)
- b. tagmatisation; (5)
- c. placenta; (5)
- d. notochord; (5)
- e. lac operon. (5)

OR

2. Use your knowledge of Biology to explain the following statements.

- a. Grasshoppers and butterflies are both insects, yet they develop in a different way. (5)
- b. A woman with type A blood and a man with type B blood have a child with type O blood and another child with type AB blood. (5)
- c. Negative and positive pressure are integral to transport systems. (5)
- d. The buccal cavity of herbivores shows adaptations that conform to the organisms' feeding habits and diet. (5)
- e. Through photosynthesis, plants are able to harness energy from sunlight and turn it into chemical energy. However, the way plants utilise carbon dioxide depends largely on the habitat. (5)

(Total: 25 marks)



SUBJECT:	Biology
PAPER NUMBER:	III
DATE:	16 th December 2020
TIME:	4:00 p.m. to 5:35 p.m.

Directions to Candidates

- Write your index number in the space at the top left-hand corner of this page.
 - Answer all questions. Write all your answers in the spaces provided in this booklet.
 - The mark allocation is indicated at the end of each question. Marks allocated to parts of questions are also indicated.
 - You are reminded of the necessity for good English and orderly presentation in your answers.
 - In calculations you are advised to show all the steps in your working, giving your answer at each stage.
 - The use of electronic calculators is permitted.
-

For examiners' use only:

Question	1	2	3	Total
Score				
Maximum	15	21	14	50

1. This question is about taxonomy.

Figure 1 illustrates two viruses that belong to two different categories.

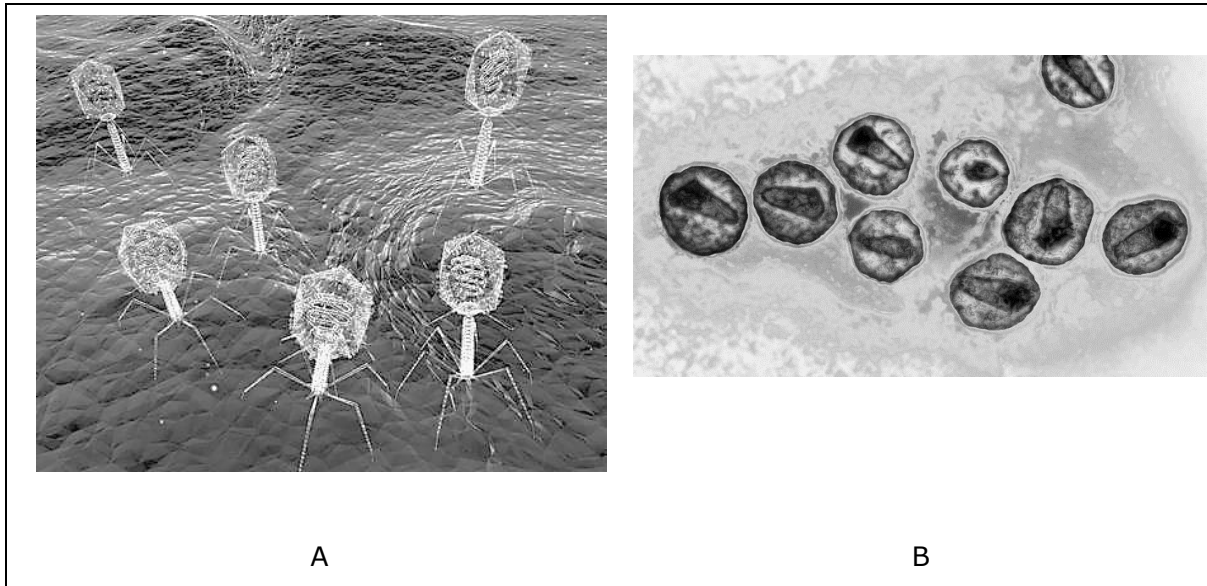

Figure 1: Viruses belonging to two different categories.
(Source: (A) <https://us.123rf.com>; (B) <https://image.cnbcfm.com>)

a. Identify the virus types in Figure 1.

A: _____ (1)



B: _____ (1)

b. Describe **ONE** visible feature that distinguishes between the two.

_____ (1)

c. Complete Table 1 by identifying the kingdoms to which organisms in Figures 2 – 7 belong. For each organism, give **ONE** visible characteristic feature.

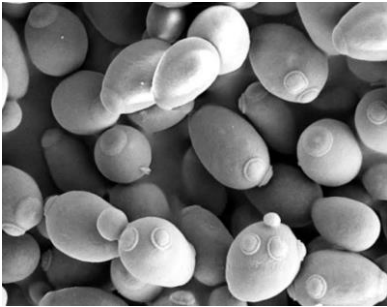
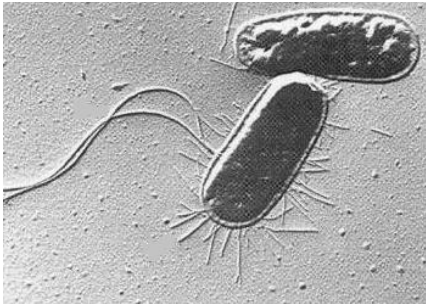
Table 1: Organisms belonging to different kingdoms

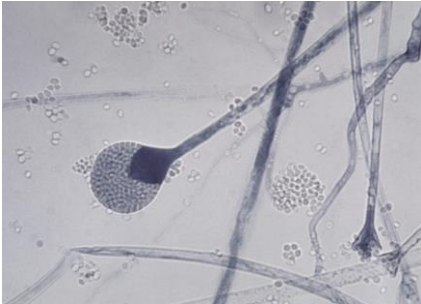
 <p>Figure 2 (Source: https://upload.wikimedia.org)</p>	<p>Kingdom: _____ (1)</p> <p>Feature: _____ (1)</p>
 <p>Figure 3 (Source: https://2007.igem.org)</p>	<p>Kingdom: _____ (1)</p> <p>Feature: _____ (1)</p>
 <p>Figure 4 (Source: https://i.pinimg.com/)</p>	<p>Kingdom: _____ (1)</p> <p>Feature: _____ (1)</p>
 <p>Figure 5 (Source: https://www.differencebetween.com)</p>	<p>Kingdom: _____ (1)</p> <p>Feature: _____ (1)</p>

This question continues on next page.

Table 1: continuation

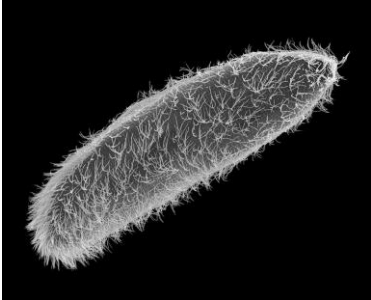
 <p>Figure 6 (the colour of the specimen is brown) (Source: https://a360-rehabpub.s3.us-west-2.amazonaws.com)</p>	<p>Kingdom: _____ (1)</p> <p>Feature: _____ (1)</p>
 <p>Figure 7 (Source: https://media.sciencephoto.com)</p>	<p>Kingdom: _____ (1)</p> <p>Feature: _____ (1)</p>

(Total: 15 marks)

2. This question is about biochemistry.

Tables 2 to 5 focus on biomolecules A to D. Fill in the tables by describing the methods used to test for the presence of these biomolecules. In each case, indicate the test to be used and give details of reagents, procedures and observations.

Table 2: Biomolecule A

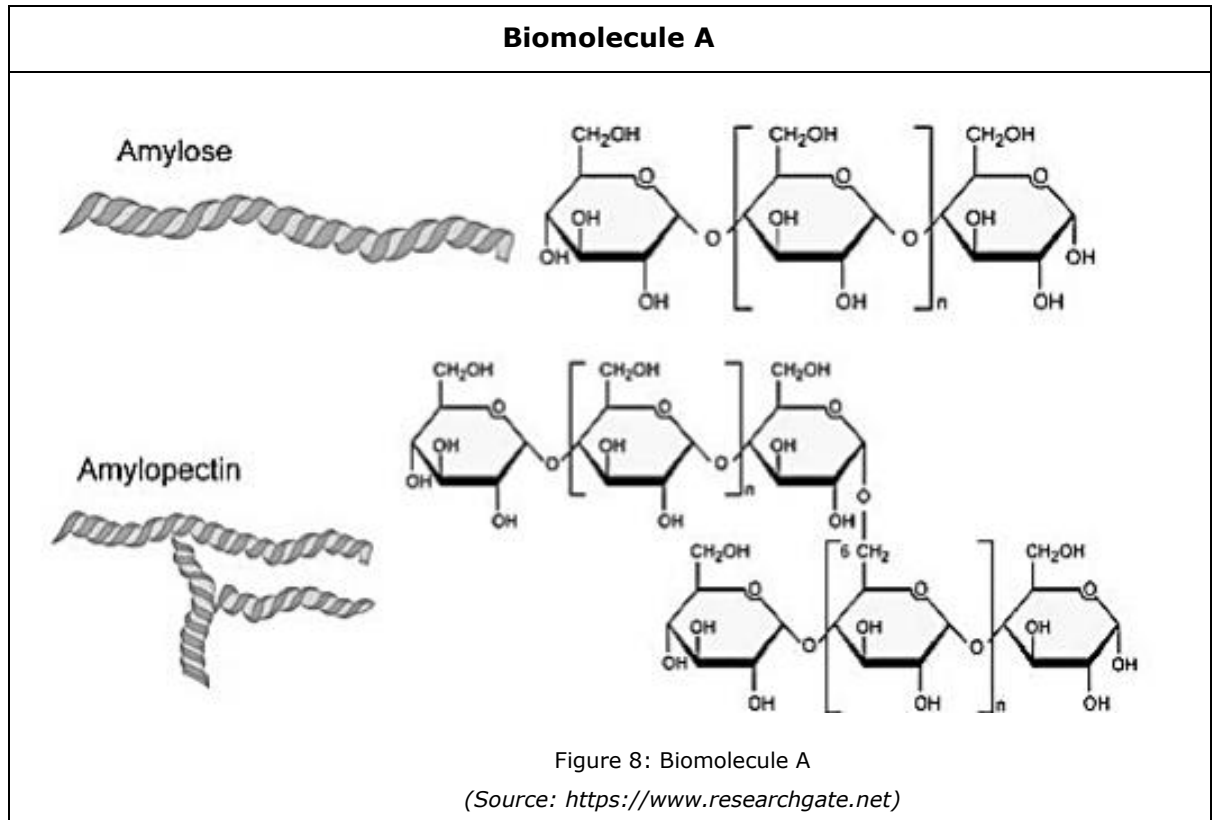

i.	Name of test:	(1)
ii.	Reagents:	(1)
iii.	Procedure:	(1)
iv.	Observations:	(1)

This question continues on next page.

Table 3: Biomolecule B

Biomolecule B	
 <p style="text-align: center;">Figure 9: Biomolecule B (Source: http://cdn.biologydiscussion.com)</p>	
i.	Name of test: (1)
ii.	Reagents: (1)
iii.	Procedure: (1)
iv.	Observations: (1)

Table 4: Biomolecule C

Biomolecule C	
 <p style="text-align: center;">Figure 10: Biomolecule C (Source: http://chemistry2.csudh.edu)</p>	
i.	Name of test: (1)
ii.	Reagents: (3)
iii.	Procedure: (2)
iv.	Observations: (1)

This question continues on next page.

Table 5: Biomolecule D

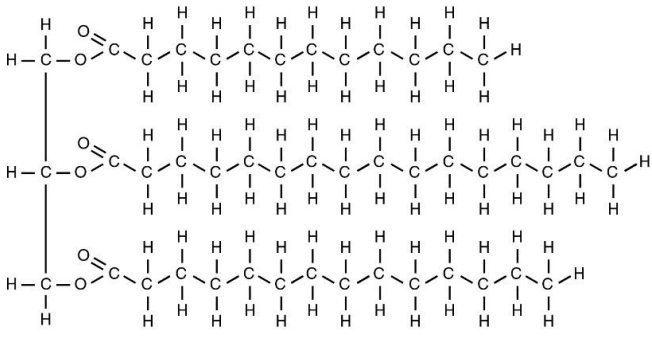
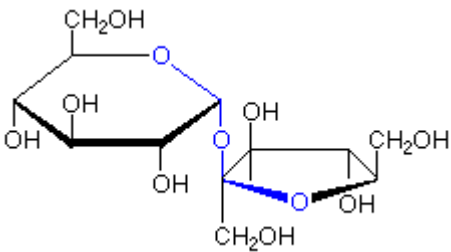
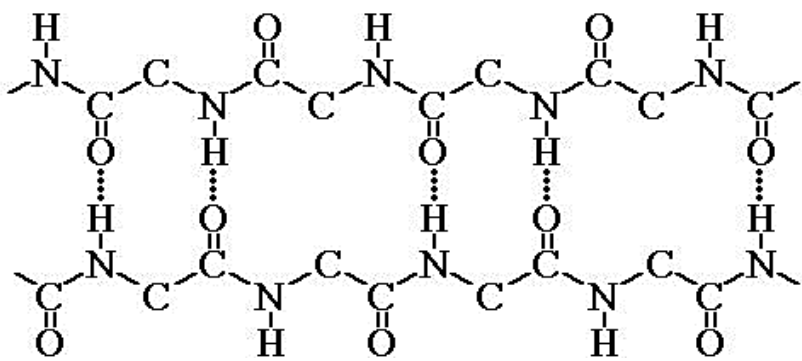
Biomolecule D	
 <p>Figure 11: Biomolecule D (Source: https://artofbiochemistry.wordpress.com/2013/02/20/1226/)</p>	
i.	Name of test: (1)
ii.	Reagents: (2)
iii.	Procedure: (2)
iv.	Observations: (1)

(Total: 21 marks)

3. This question is about locomotion.

The different stages of earthworm locomotion were studied by placing some earthworms in the middle of a large sheet of paper. The movement of each worm was observed, and the researchers listened carefully for any particular sound. The different stages of movement were documented photographically.

Figures 12 and 13 below are two photographs that were captured during this experiment. These photos were taken within seconds of each other and show the same earthworm undergoing different movement.



Figure 12: Earthworm movement: Stage 1

(Source: <http://www.nuffieldfoundation.org/practical-biology/observing-earthworm-locomotion>)



Figure 13: Earthworm movement: Stage 2

(Source: <http://www.nuffieldfoundation.org/practical-biology/observing-earthworm-locomotion>)

- a. Observe these two photos and identify which part of the earthworm's body remained anchored in both photos and which part propelled. Mark and label these body parts on Figures 12 and 13. (2)
- b. Which visual observations led you to your answer to part (a) above?

(2)

This question continues on next page.

c. Explain the stages of forward movement observed in Figures 12 and 13 above in terms of circular and longitudinal muscles and the hydrostatic skeleton in earthworms.

(5)

d. A faint scratching sound was observed while the earthworm propelled forward. Identify the appendage that caused that particular sound?

(1)

e. Explain the main role of the appendage given as an answer to part (d) in locomotion of these worms.

(1)

f. In the second part of the experiment, the earthworm was placed in the middle of a glass sheet instead.

i. How would you expect the resulting observations of this set-up to differ from the previous set-up?

(1)

ii. Explain your answer to part (i).

(2)

(Total: 14 marks)

Blank Page