



SUBJECT: **Biology**
 PAPER NUMBER: I
 DATE: 9th May 2023
 TIME: 9:00 a.m. to 12:05 p.m.

Directions to Candidates

- Write your index number in the space at the top left-hand corner of this page.
- Answer **ALL** questions. Write all your answers in the spaces provided in this booklet.
- The mark allocation is indicated at the end of each question. Marks allocated to parts of questions are also indicated.
- You are reminded of the necessity for good English and orderly presentation in your answers.
- In calculations you are advised to show all the steps in your working, giving your answer at **each** stage.
- The use of electronic calculators is permitted.

For examiners' use only:

Question	1	2	3	4	5	6	7	8	Total
Score									
Maximum	13	15	10	12	12	16	8	14	100

1. This question is about biomolecules.

a. One of the main functions of carbohydrates is to provide energy to the cell. One such carbohydrate in the human body is glycogen.

i. Name the **TWO** main repositories of glycogen in the human body.

_____ (1)

ii. Explain how glycogen can provide the human body with an immediate source of energy.

_____ (2)

iii. In which situations is glycogen used as a source of energy?

_____ (2)

iv. Explain why glycogen is a convenient storage molecule.

_____ (2)

b. Lipids are also associated with energy storage molecules.

i. State what the building blocks of lipids are.

_____ (1)

ii. List **TWO** functions of lipids in the human body (apart from energy storage).

(1)

c. ATP is sometimes referred to 'energy currency of the cell'.

i. What does the abbreviation 'ATP' stand for?

(1)

ii. Name the type of reaction that enables ATP to release its energy.

(1)

iii. Briefly describe the relationship between ATP and creatine phosphate?

(2)

(Total: 13 marks)

2. This question is about hormones.

a. Explain the following statements:

i. Release-inhibiting neurohormones cannot instigate a positive feedback loop.

(2)

ii. Peptide hormones bind to cell surface receptors to exert their effects.

(2)

Question continues on next page.

iii. Steroid hormones need a carrier protein to be transported through the blood.

(2)

iv. Protein hormones do not form intracellular hormone-receptor complexes.

(2)

v. The posterior pituitary is sometimes referred to as the 'non-producing lobe' of the pituitary gland.

(2)

Controlling hormone activity is essential for homeostasis. One of the hormones controlled by the hypothalamus is antidiuretic hormone (ADH). By working with baroreceptors within the kidneys, the hypothalamus would signal the production or inhibition of ADH.

The plot in Figure 1 shows the relationship between the concentration of urine, labelled as 'Urine Osmolarity' and the ADH concentration in blood.

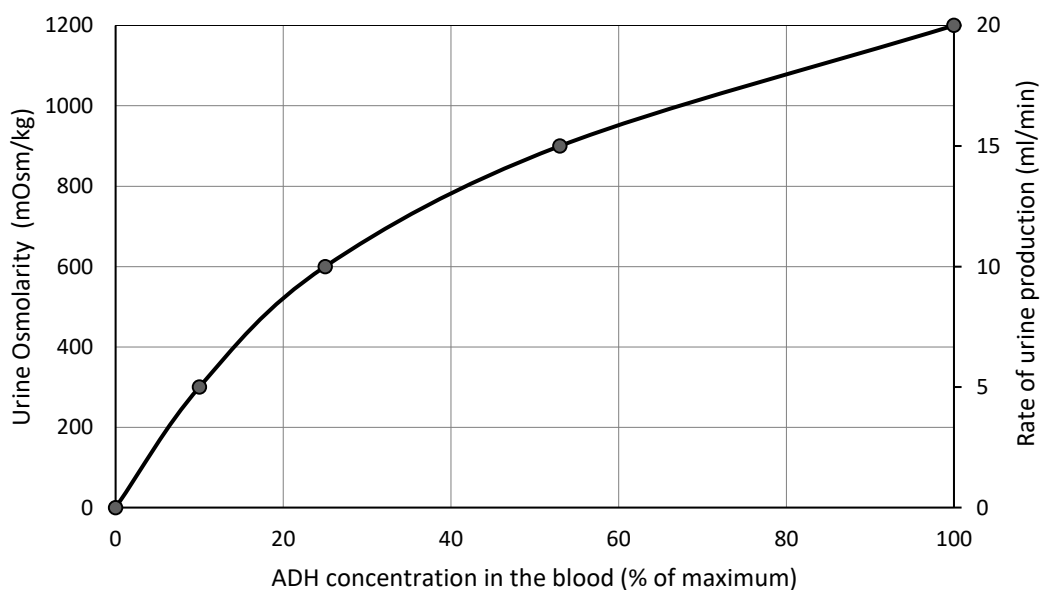

Figure 1: A plot showing the relationship between Urine Osmolarity and ADH concentration in the blood. (Adapted from: <https://www.physiologyweb.com>)

-
- b. Using the same scale and axes in Figure 1, sketch another plot to illustrate the expected change in the rate of urine production as ADH concentration increases. (2)
 - c. Explain why ADH deficiency could lead to dehydration.

(3)

(Total: 15 marks)

3. This question is about locomotion and support in vertebrates.

- a. The individual vertebrae of the vertebral column of the human body are superficially similar to each other in their morphology. However, there are important differences between vertebrae in different parts of the vertebral column. Give **ONE** possible reason for these differences.

(2)

- b. List **TWO** advantages, in terms of support, that the articular processes of vertebrae (prezygapophysis and postzygapophysis) provide.

(2)

- c. The limbs of early amphibians emerged horizontally from their body. However, millions of years later, their descendants, including the dinosaurs, had limbs oriented vertically below their body. Explain the advantage of this change in terms of locomotion and support.

(2)

Question continues on next page.

d. Some reptiles and mammals have evolved a bipedal gait. Identify **ONE** advantage and **ONE** disadvantage of this trait.

Advantage: _____
_____ (1)

Disadvantage: _____
_____ (1)

e. Mammals possess a flexible connection between the pectoral girdle and vertebral column. Give **TWO** advantages of this arrangement.

_____ (2)

(Total: 10 marks)

4. This question is about stimulus reception in plants.

Several experiments have been carried out to investigate the effects of hormones on plant responses. Figures 2 and 3 illustrate two experiments related to phototropism in coleoptiles.

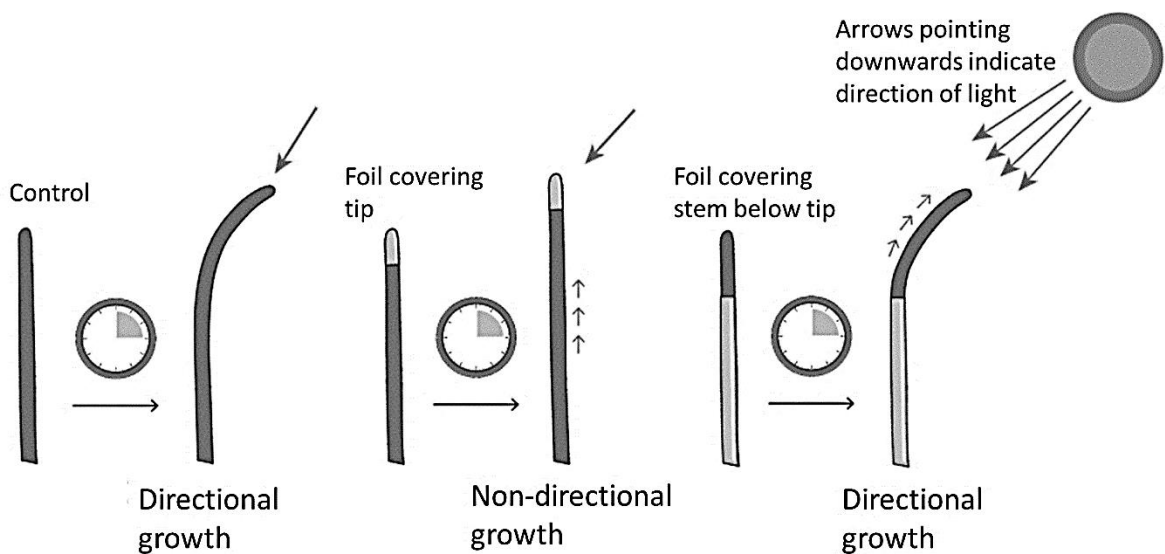

Figure 2: A diagram showing Darwin's experiments on phototropism.
(Adapted from <https://www.nagwa.com>)

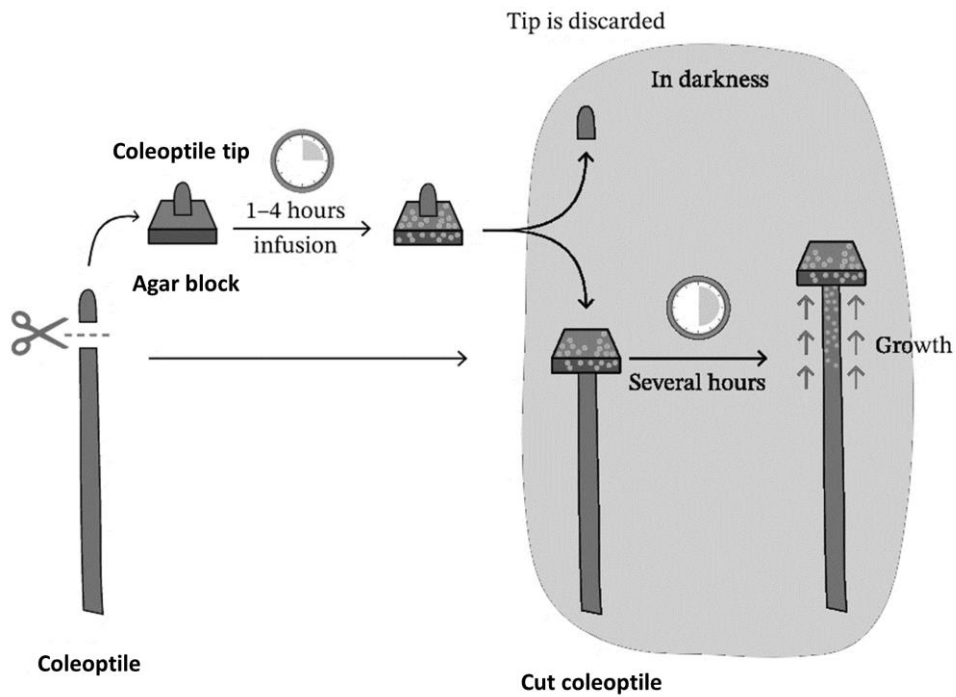

Figure 3: A diagram showing one of Went's experiments using an agar block.
(Obtained from <https://www.nagwa.com>)

a. Identify the plant hormone responsible for the responses observed in Figures 2 and 3.
_____ (1)

b. What conclusions can be drawn from the experiments illustrated in Figure 2? In your answer indicate the biological significance of these conclusions.

_____ (3)

c. Explain the outcome of the experiment in Figure 3.

_____ (2)

Question continues on next page.

- d. Considering Figure 3, what outcome is expected should the agar block be placed on one side of the coleoptile stump?

(2)

- e. List **FOUR** ways in which the hormone mentioned in your answer to part (a) can affect plant growth.

(4)

(Total: 12 marks)

5. This question is about water movement in plants.

- a. Transpiration allows water to move through a plant. There are two important properties of water molecules that allow a stream of water to move against gravity in a plant's shoot. Name the **TWO** properties mentioned in the statement above and explain why they are important for water movement to occur.

(3)

- b. Differences in water potential between systems influence the rate of water movement. A scientist wanted to observe how differences in water potentials would influence transpiration. For this experiment red dye was added to soil water and the scientist observed the rate at which the dye reached the leaves of the plant.

The data in Table 1 has been collected for the same species subjected to different environmental conditions.

Table 1: A table showing the water potential in the soil and various parts of the plant.

	Ψ soil (MPa)	Ψ root (MPa)	Ψ stem (MPa)	Ψ leaf (MPa)
Plant A	-0.5	-0.6	-0.7	-0.8
Plant B	-0.3	-0.4	-0.3	-0.3
Plant C	0	-0.4	-0.6	-1.0

By using the information in Table 1, determine which plant is associated with **each** statement in the questions that follow. Give **ONE** reason to justify your choice.

- i. The plant that would show the first signs of the red dye within its leaves.

Plant: _____

Reason: _____

_____ (2)

- ii. The plant that would show signs of the red dye within its leaves but at a slower rate than the quickest plant.

Plant: _____

Reason: _____

_____ (2)

- iii. The plant that would **not** show any sign of the red dye in its leaves.

Plant: _____

Reason: _____

_____ (2)

- c. Plant species are adapted to live in different environmental conditions. List **THREE** adaptations of xerophytic plants.

_____ (3)

(Total: 12 marks)

Please turn the page.

6. This question is about genetic inheritance.

a. The following queries were asked to a geneticist. Using your knowledge on inheritance suggest an answer to these queries.

i. Query: "Genes and alleles do **not** mean the same thing."

Explanation: _____

_____ (4)

ii. Query: "Although there is blood group AB, blood group AO does **not** exist. The latter is classified as blood group A."

Explanation: _____

_____ (3)

iii. Query: "I have brown eyes, and my mother has blue eyes. I was told that because of my genetic constitution, I have the possibility of having children with blue eyes."

Explanation: _____

_____ (4)

b. The pedigree diagram in Figure 4 shows the inheritance pattern of a syndrome that affects the connective tissue of the body.

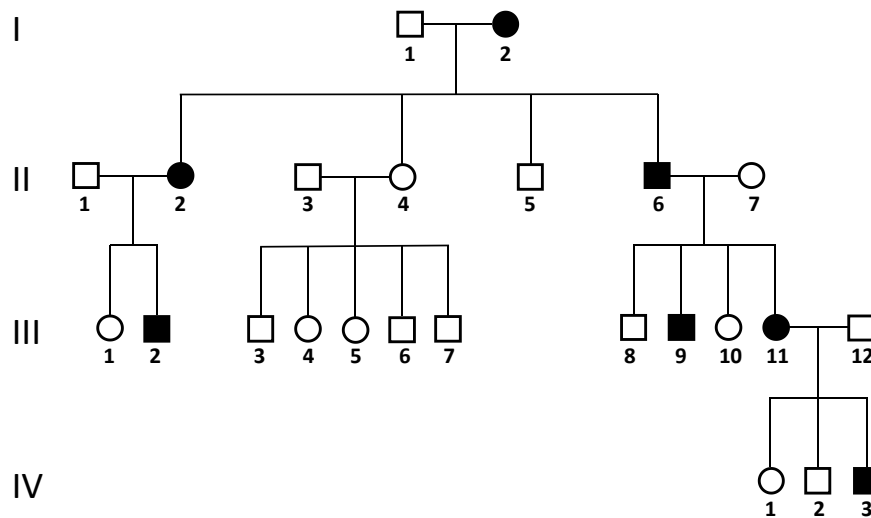

Figure 4: A pedigree diagram showing the inheritance pattern of the syndrome effecting the connective tissue.

[key: □ unaffected male; ■ affected male; ○ unaffected female; ● affected female]

i. What type of inheritance pattern is shown by the pedigree diagram in Figure 4?

(1)

ii. List **TWO** features of this pedigree diagram that point to the particular inheritance pattern you listed in your answer to part (b)(i) above.

(2)

c. The pedigree diagram in Figure 5 shows the inheritance pattern of neurological condition that affects the central nervous system.

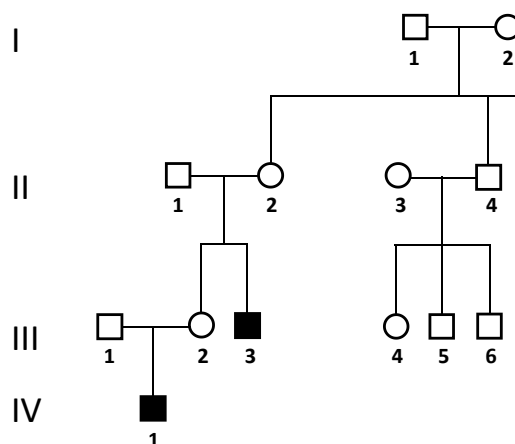

Figure 5: A pedigree diagram showing the inheritance pattern of the neurological condition.

[key: □ unaffected male; ■ affected male; ○ unaffected female; ● affected female]

Question continues on next page.

i. What type of inheritance pattern is shown by the pedigree diagram in Figure 5?

(1)

ii. List **ONE** feature of this pedigree diagram that points to the particular inheritance pattern you listed in your answer to part (c)(i) above.

(1)

(Total: 16 marks)

7. Plant reproduction cycles tend to follow climatic cycles.

The data in Figure 6 and Figure 7 represents the climatic conditions of a European country.

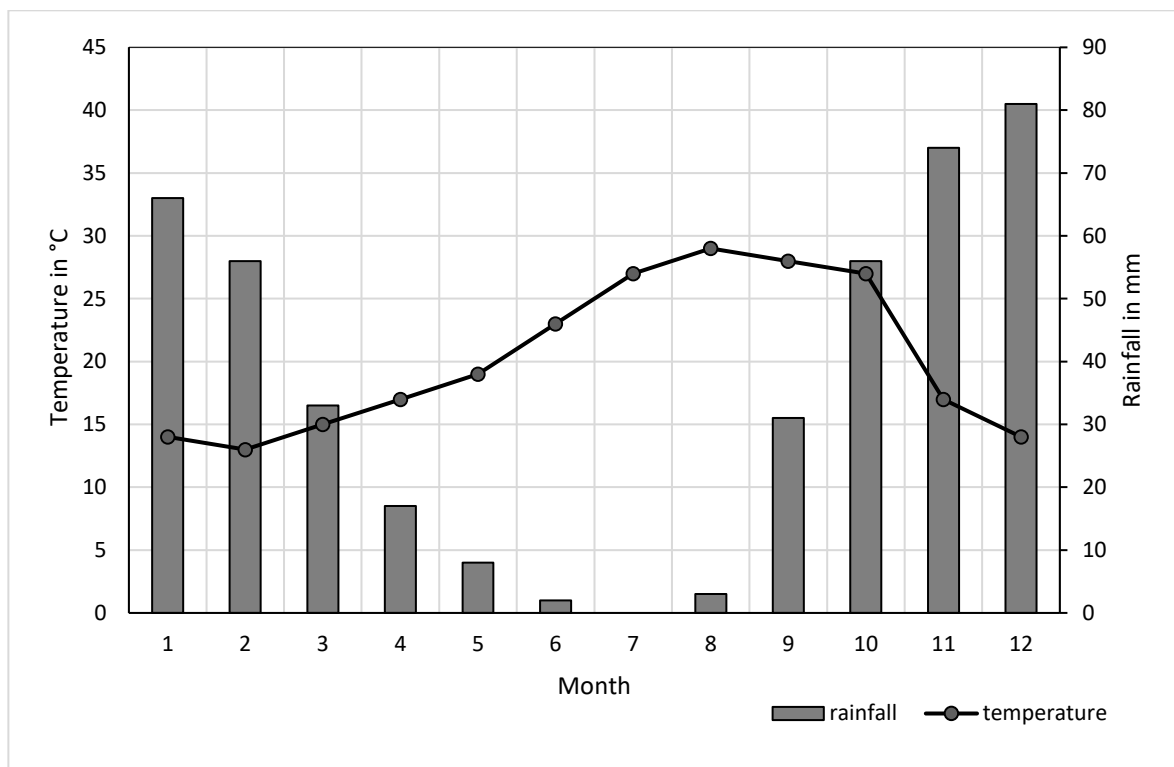
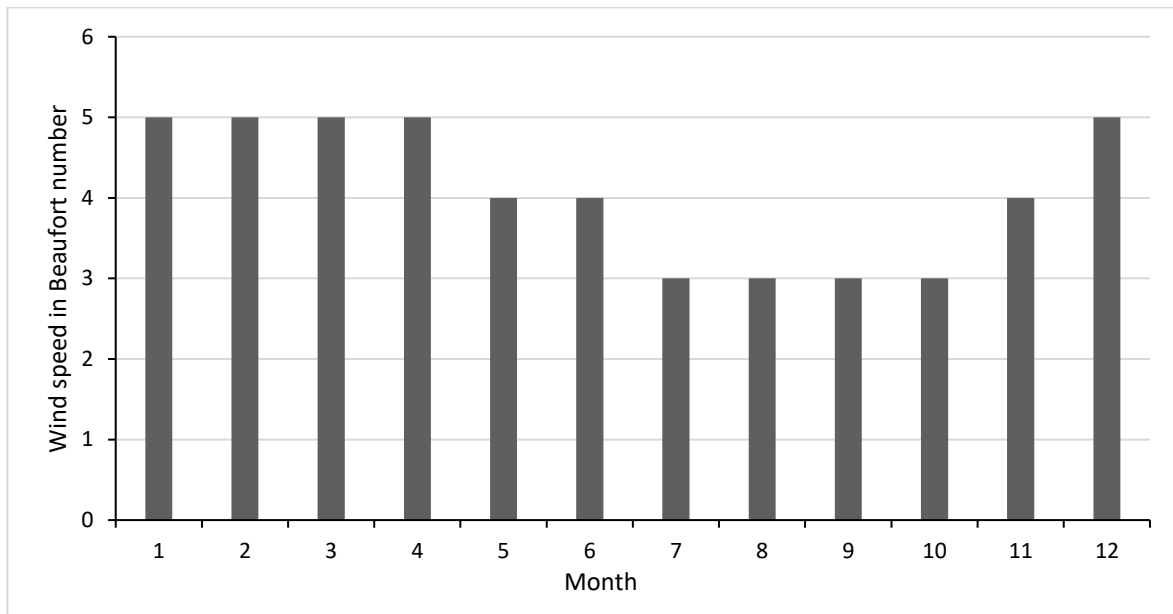

Figure 6: A graph showing the average monthly temperature and average monthly rainfall of the European country.

(Adapted from: <https://en.climate-data.org/europe>)

DO NOT WRITE ABOVE THIS LINE



Beaufort number: higher values indicate stronger winds.

Figure 7: A graph showing the average monthly wind speed of the European country. (Adapted from: <https://weather-and-climate.com>)

- a. List **ONE** month during which you would expect the following to occur.
 - i. Vegetative propagation: _____ (1)
 - ii. Flowering: _____ (1)
 - iii. Seed dormancy: _____ (1)

- b. Explain why some flowering plants alternate between sexual and asexual reproduction at different times of the year.

_____ (2)

- c. Which of these climatic conditions are likely to be most relevant to anemophilous plants?
_____ (1)

- d. Explain why the climate shown in these figures is not very suitable for bryophytes.

_____ (2)

(Total: 8 marks)

Please turn the page.

8. This question is about evolution.

a. Figure 8 is showing two graphs for different traits in a human population.

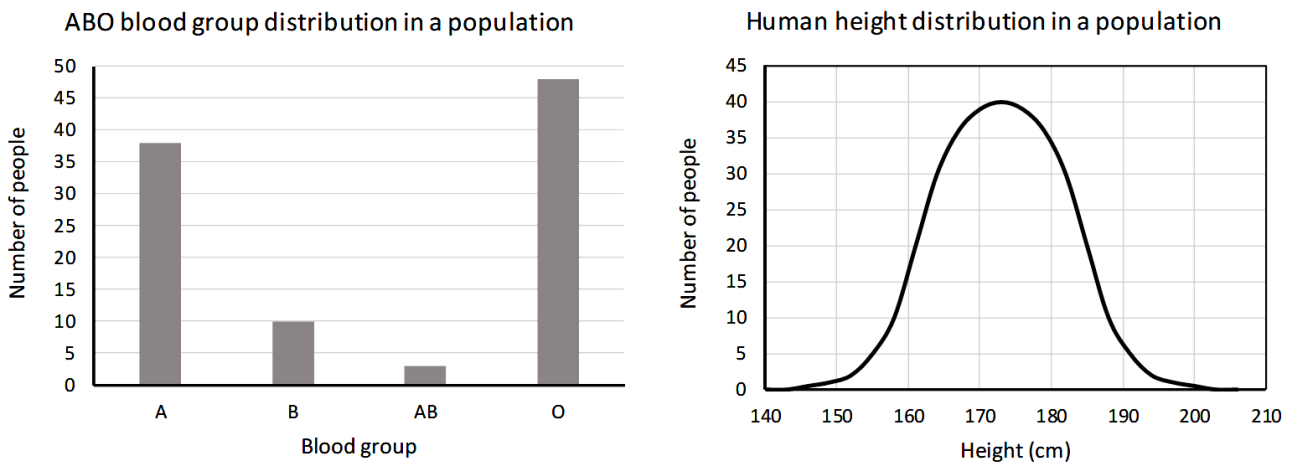

Figure 8: Variation for two traits in a human population
(left: blood group; right: height)

Which graph is depicting continuous variation in the trait and which graph is depicting discontinuous variation in the trait? Justify your answer.

(3)

b. Why is genotypic variation **not** necessarily reflected in phenotypic variation?

(4)

c. i. Define the term 'polyploidy'.

_____ (1)

ii. Explain how polyploidy can arise.

_____ (3)

iii. Explain how polyploidy can lead to speciation in plants.

_____ (3)

(Total: 14 marks)

Blank Page



SUBJECT:	Biology
PAPER NUMBER:	II
DATE:	9 th May 2023
TIME:	4:00 p.m. to 7:05 p.m.

Directions to Candidates

- Answer the question in Section A, any **TWO** questions from Section B and **ONE** question from Section C. Write all your answers in the separate booklet provided.
 - If more than two questions from Section B are attempted, only the first two answers shall be taken into consideration.
 - If more than one question from Section C is attempted, only the first answer shall be taken into consideration.
 - The mark allocation is indicated at the end of each question. Marks allocated to parts of questions are also indicated.
 - You are reminded of the necessity for good English and orderly presentation in your answers.
 - In calculations you are advised to show all the steps in your working, giving your answer at each stage.
 - The use of electronic calculators is permitted.
-

SECTION A

1. Read the following extract carefully, and using the information provided and your knowledge of biology, answer the questions that follow. The numerals in the left-hand margin are the line numbers.

Colonisation of the alpine tundra by trees

Given the expected increase in global temperatures, scientists are predicting that treeline positions of alpine trees will shift upward in elevation in the coming decades. This could result in substantial modification of current alpine plant community composition and diversity.

5 This is evident from trees invading subalpine meadows and of subalpine shrubs and trees expanding into the treeless alpine zone. The expansion into the alpine environment requires certain adaptations for seed dispersal, germination and successful establishment.

10 The expansion in range of a species may place its pioneer individuals in an environment where their fitness is reduced relative to the populations in their original range. In addition to exposure to solar radiation extremes, previous works have linked conifer seedling mortality with low volumetric soil water content and with drought stress, especially during summer months.

15 Therefore, the capacity to establish in a new environment depends, in part, on the life history traits and physiological properties of a species. Early successional tree species are expected to be adapted to high sun radiation and warmer temperatures, while late successional species may be more sensitive to fluctuating microclimates. Due to these differing ecological strategies, early or late seral species may demonstrate expectations in the patterns of ecological succession.

20 In the treeline of the Colorado Front Range (USA), *Picea engelmannii* (Engelmann spruce) and *Pinus flexilis* (Limber pine) are widely distributed conifers. *Pinus flexilis* is a shade-intolerant species that can persist under conditions of high solar radiation and dry infertile soils as found on mountains, while *P. engelmannii* is a species tolerant to shade and adapted to higher moisture substrates. Therefore, *P. flexilis* is adapted to low soil moisture as demonstrated by higher intrinsic water use efficiency, a slower growth rate and reliance on seed reserves when compared with *P. engelmannii*. Additionally, previous studies have found that survival and photosynthesis were reduced in *P. engelmannii* seedlings in the absence of cover from
25 neighbouring plants. Now questions arise on whether climate warming will alter these important interactions between tree seedlings and neighbouring plants as seedlings establish beyond their current range margins.

(Adapted from: Meredith DJ, Matthew JG, Lara MK (2020) Colonisation of the alpine tundra by trees: alpine neighbours assist late-seral but not early-seral conifer seedlings, *Plant Ecology & Diversity*, 13: 209-224)

- a. Define the term 'ecological succession' (line 17). (2)
- b. Suggest why alpine habitats, which occur at around 3000 metres above mean sea level, are characterized by 'high solar radiation and dry infertile soils' (line 20). (2)
- c. Distinguish between the terms 'early seral species' and 'late seral species' in a succession (line 16). (4)
- d. Explain why the physiological characteristics of *Pinus flexilis* adapt it for the early stages of an alpine ecological succession. (3)
- e. Explain why the physiological characteristics of *Picea engelmanni* adapt it for the later stages of an alpine ecological succession. (3)
- f. Briefly explain the following statement, 'The expansion in range of a species may place its pioneer individuals in an environment where their fitness is reduced relative to the populations in their original range.' (lines 7 – 8). (3)
- g. Trees are primary producers. Distinguish between gross primary production and net primary production. (2)
- h. The primary producers mentioned in the text belong to the kingdom Plantae. Give **ONE** example of a primary producer that does **not** belong to the kingdom Plantae. (1)
- i. Give the main cause leading to an 'increase in global temperatures' (line 1). (1)
- j. List **FOUR** different threats to biodiversity, other than increasing global temperatures. (4)

(Total: 25 marks)

Please turn the page.

SECTION B

Answer any TWO questions from this section; your answers should take the form of essays. Each question carries twenty-five marks.

1. Outline the processes associated with photorespiration in C₄ and CAM plants.
2. Genetic changes can occur during DNA replication and/or cell division. Discuss.
3. In gene technology, scientists need to obtain a copy of the required gene and transfer it into the host cells. Describe the stages involved in these processes.
4. Compare and contrast artificial selection and natural selection.

(Total: 50 marks)

SECTION C

Answer ONE question from this section.

1. Use your knowledge of biology to distinguish between each of the following pairs:
 - a. Ferns and mosses. (5)
 - b. Vertebrates and invertebrates. (5)
 - c. Cnidaria and Echinodermata. (5)
 - d. Insecta and Arachnida. (5)
 - e. Platyhelminthes and Annelida. (5)

(Total: 25 marks)

OR

2. Use your knowledge of biology to explain the following statements:
 - a. Adrenaline and glucagon are two hormones that stimulate the synthesis of glucose in different situations. (5)
 - b. Burrowing is a thermoregulatory behaviour in some animals. (5)
 - c. The liver forms part of a portal system that allows it to exert its homeostatic functions more efficiently. (5)
 - d. The flow of tubular fluid within a nephron is essential for osmoregulation. (5)
 - e. Rhesus-negative human females may instigate haemolytic disease in their offspring whilst rhesus-positive females do not. (5)

(Total: 25 marks)



SUBJECT: **Biology**
PAPER NUMBER: III
DATE: 10th May 2023
TIME: 9:00 a.m. to 10:35 a.m.

Directions to Candidates

- Write your index number in the space at the top left-hand corner of this page.
 - Answer **ALL** questions. Write all your answers in the spaces provided in this booklet.
 - The mark allocation is indicated at the end of each question. Marks allocated to parts of questions are also indicated.
 - You are reminded of the necessity for good English and orderly presentation in your answers.
 - In calculations you are advised to show all the steps in your working, giving your answer at each stage.
 - The use of electronic calculators is permitted.
-

For examiners' use only:

Question	1	2	3	Total
Score				
Maximum	12	18	20	50

1. This question is about the variety of living organisms.
- a. The electron micrographs in Figures 1 and 2 represent two species from the same kingdom.

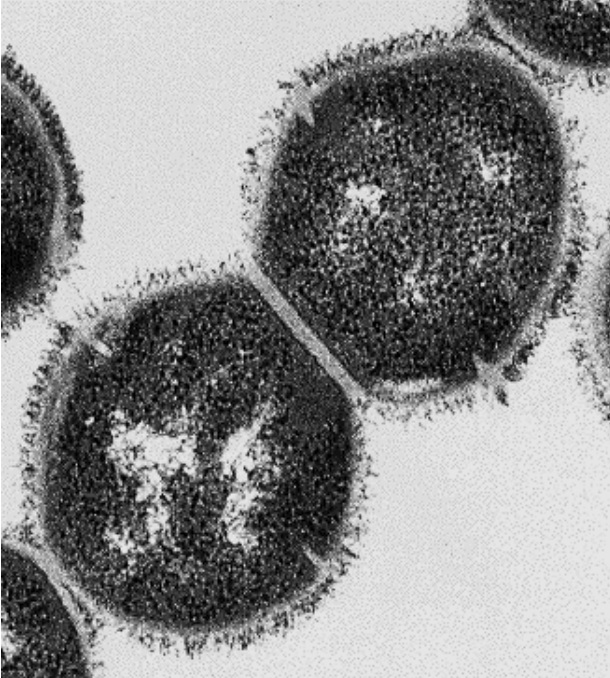

Figure 1

(obtained from: <https://microbewiki.kenyon.edu>)

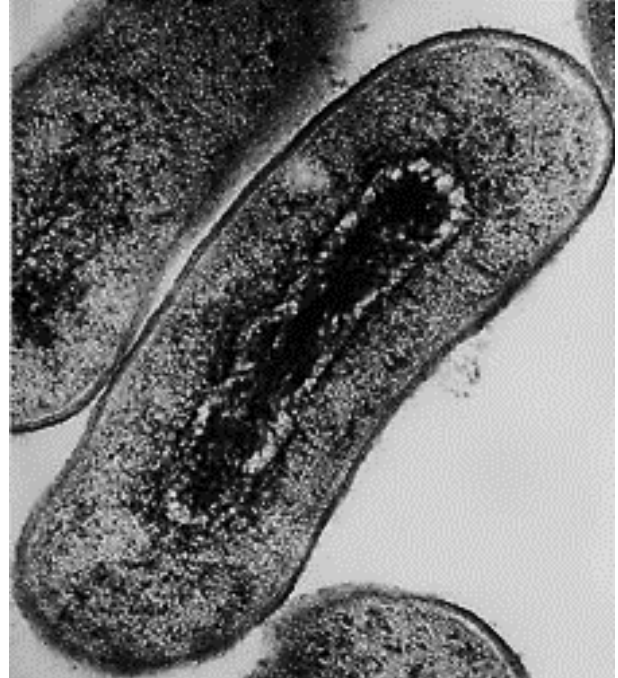

Figure 2

(obtained from: <https://www.shutterstock.com>)

- i. Identify the kingdom in which these two species are classified.

_____ (1)

These two organisms were treated with crystal violet dye, followed by iodine, alcohol washing and safranin. At the end of the procedure, the organism in Figure 1 stained violet, while the one in Figure 2 stained red.

- ii. What can be concluded about these organisms from the resulting stains, and why do the organisms stain differently?

_____ (2)

b. The organisms shown in Figures 3 and 4 are both tracheophytes.

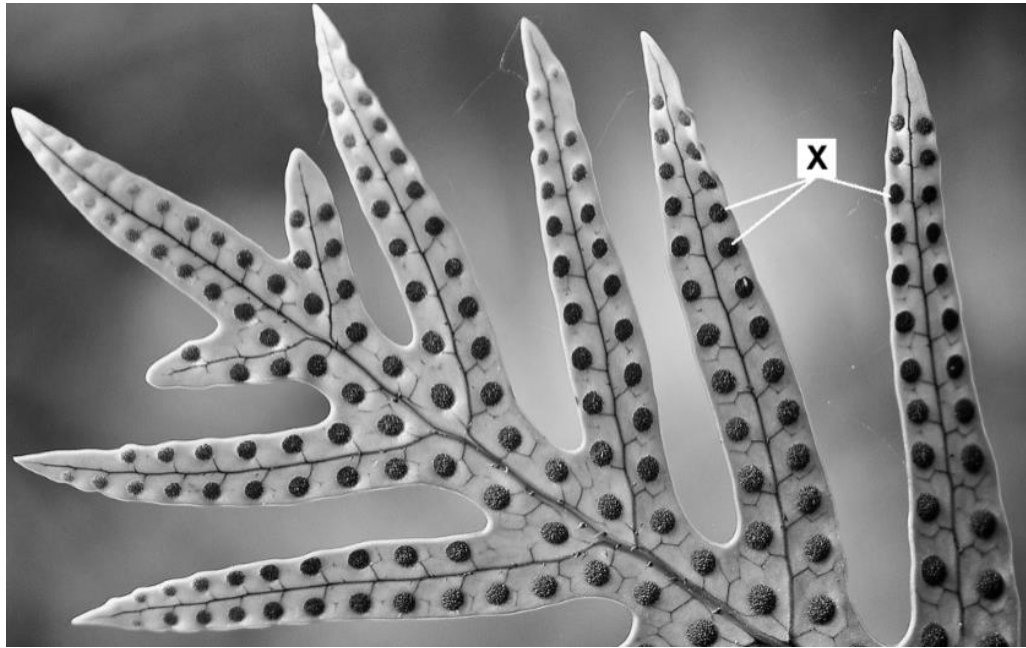

Figure 3
(Adapted from: <https://live.staticflickr.com>)

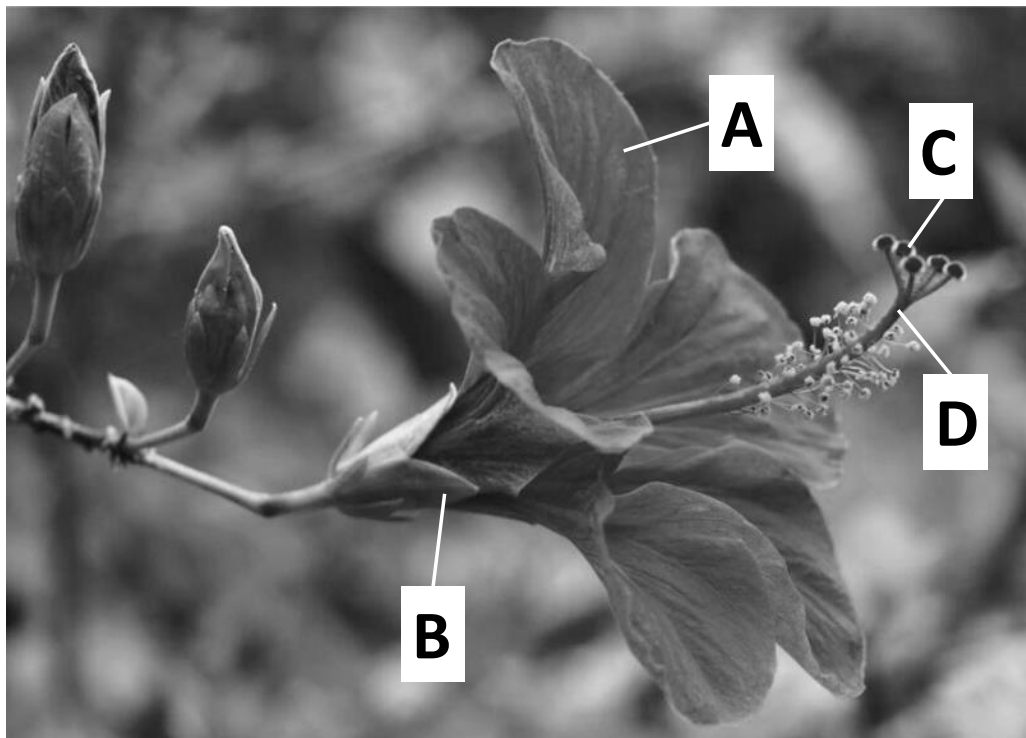

Figure 4
(Adapted from: <https://plantura.garden>)

i. Name a taxon within the Tracheophyta within which each organism is classified.

Figure 3: _____

Figure 4: _____

(2)

Question continues on next page.

- ii. What are the structures labelled X (Figure 3) and what is their function?

Label for structures X: _____

Function of structures X: _____

(2)

- iii. Provide the appropriate labels for structures A to D (Figure 4).

Structure:	Label:
A	
B	
C	
D	

(4)

- iv. The species shown in Figure 4 is a dicot. Define the term 'dicot'.

(1)

(Total: 12 marks)

2. This question is about enzyme activity.

As shown in the chemical equation below, the enzyme catalase catalyses the decomposition of hydrogen peroxide into water and oxygen. Oxygen gas production can be easily observed and measured in the lab, allowing the researcher to make quantitative observations in the changes related to enzymatic activity.

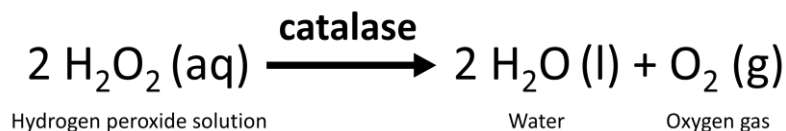

In this study, three different experiments were carried out to analyse the effect of enzyme concentration, substrate concentration and inhibition on the activity of the catalase.

The enzyme catalase used in this experiment was extracted from raw potatoes by blending them with cold water to form a solution.

- a. Explain why it was important to blend raw potatoes rather than cooked ones for the extraction of catalase.

(1)

Experiment 1: Effect of Substrate Concentration on Catalase Activity

Method:

Eight tubes with different concentrations of hydrogen peroxide solution were prepared and labelled 1 to 8 (Table 1).

A solution having a catalase concentration of 100 units/mL was used for all the tests. A filter paper disk was dipped in the catalase solution and then placed at the bottom of substrate solution tube 1. The time taken for the filter paper disc to rise to the surface, due to the production of oxygen from the reaction, was noted and recorded.

The same experiment was then repeated for the remaining substrate concentrations in tubes 2 to 8.

Results:

Table 1: The effect of substrate concentration on the rate of enzyme activity.

Test Tube	Hydrogen peroxide (substrate) concentration (%)	Time taken for the disc to float to the surface (s)	Rate of Reaction 1/time (s^{-1})
1	0.1	25.23	0.04
2	0.2	15.53	0.06
3	0.3	11.07	0.09
4	0.5	8.37	0.12
5	0.8	7.10	0.14
6	1.0	5.33	0.19
7	2.0	4.03	0.25
8	3.0	2.17	0.46

- b. Explain the effect of increased substrate concentration on the rate of the reaction as shown by the results of experiment 1 (Table 1).

(2)

- c. Was the saturation point in experiment 1 reached? Explain.

(2)

Experiment 2: Effect of Enzyme Concentration on Catalase Activity.

Method:

Seven tubes with different concentrations of catalase were prepared and labelled A to G (Table 2).

A filter paper disk was dipped in catalase tube A and then placed in a tube with 1% hydrogen peroxide solution. The time taken for the filter paper disc to rise to the surface was noted and recorded.

The whole procedure was then repeated for the remaining enzyme concentrations B to G.

Results:

Table 2: The effect of enzyme concentration on the rate of enzyme activity.

Test Tube	Enzyme Concentration (units/mL)	Time taken for the disc to float to the surface (s)	Rate of Reaction $1/\text{time}$ (s^{-1})
A	100	5.40	
B	85	5.50	
C	70	7.15	
D	55	10.00	
E	40	15.55	
F	25	26.30	
G	10	50.10	

- d. Fill in the last column of Table 2 by calculating the rate of the reaction (s^{-1}) for the different enzyme concentrations. Give your answers to two decimal places. (1)
- e. Using the graph paper provided (on the following page), plot a graph to show the relationship between varying enzyme concentrations and the rate of enzymatic activity (Table 2). (5)
- f. Explain the trend shown by the graph drawn on the following page.

(3)

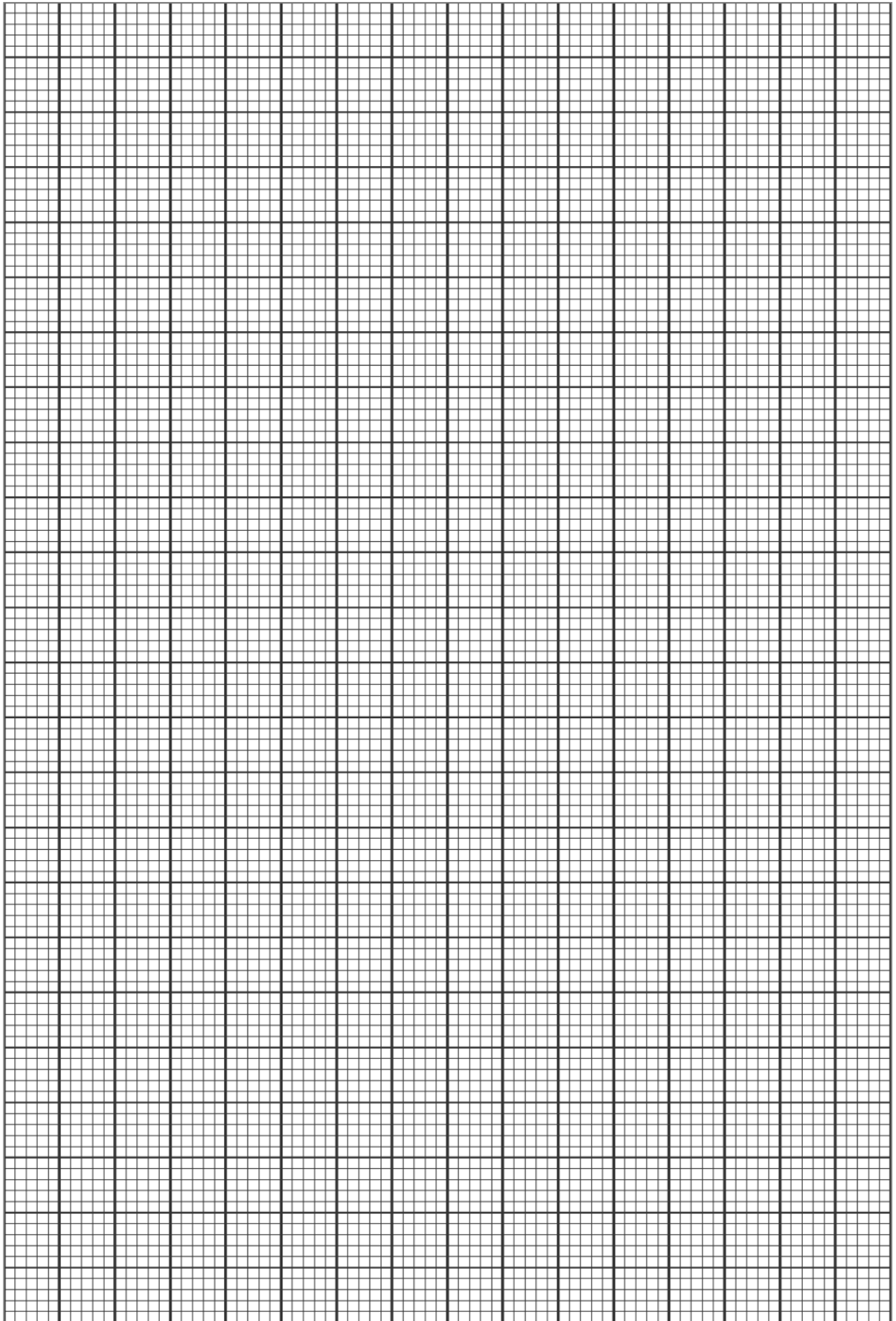

Experiment 3: Effect of Hydroxylamine on Catalase Activity.

Hydroxylamine is a known enzyme inhibitor. It binds to the active site of certain enzymes, inhibiting the substrate from binding, thereby decreasing the rate of enzyme activity. This experiment was carried out to study whether hydroxylamine inhibits the activity of catalase.

Method:

Two test tubes labelled J and K were filled with equal volumes of hydrogen peroxide solution.

Two beakers labelled 1 and 2, were filled with 1 mL of enzyme extract. In beaker 2, five drops of 10% hydroxylamine were added to the enzyme. A filter paper disc was immersed in the enzyme solution of beaker 1 and inserted at the bottom of test tube J, while another filter paper disc was immersed in beaker 2 and inserted at the bottom of test tube K. The time taken for the disc to float to the surface was recorded for each tube.

Results:

Table 3: The effect of hydroxylamine on the rate of enzyme activity.

Test Tube	Presence of hydroxylamine	Time taken for the disc to float to the surface (s)	Rate of Reaction $1/\text{time}$ (s^{-1})
J	Absent	2.4	0.42
K	Present	69.9	0.01

g. What is the role of test tube J in this experiment?

_____ (1)

h. What can be concluded from the results of this experiment?

_____ (1)

i. Is hydroxylamine classified as a competitive or a non-competitive inhibitor? Explain your answer by referring to how these two types of inhibitors work.

 _____ (2)

(Total: 18 marks)

3. This question is about circulation in mammals.

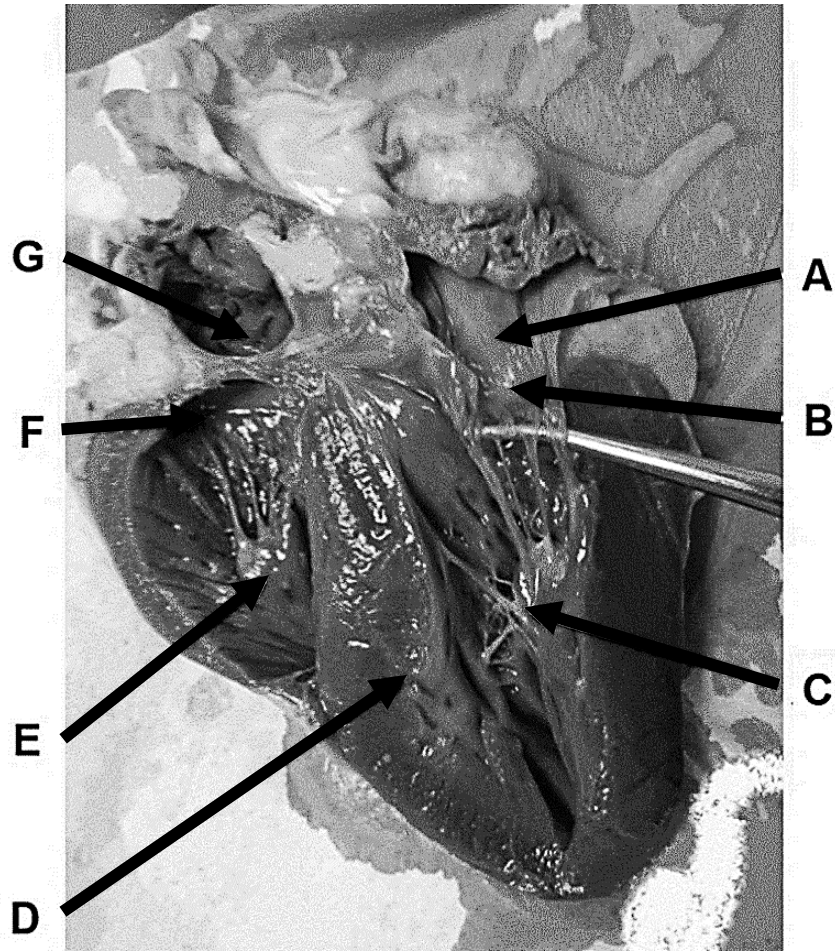

Figure 5: The image above shows the internal anatomy of a dissected sheep heart. (Adapted from: <https://slideplayer.com>)

a. Provide the appropriate labels for structures A to G shown in Figure 5.

Structure:	Label:
A	
B	
C	
D	

Structure:	Label:
E	
F	
G	

(4)

Question continues on next page.

- b. The paragraph below describes the circulation of blood through the mammalian heart. Complete the paragraph by filling in the blanks.

Deoxygenated blood enters the heart from the body through the _____ and into the _____. The blood flow is then pushed through the _____ into the _____. Blood is then pumped to the lungs where it becomes _____. The blood is brought back to the heart by the _____ and enters the _____. The blood then flows into the _____, and is not allowed to flow back by the _____. _____ blood leaves the heart through the _____ and _____ to the heart muscle and the body respectively. (6)

- c. Explain the difference noted in the walls of structures C and E shown in Figure 5.

(2)

At rest, the human heart pumps about 4 to 6 L of blood per minute. The volume of blood pumped per minute is referred to as cardiac output. The cardiac output is the product of the heart rate and stroke volume (equation represented below).

$$\text{Cardiac output (mL / min)} = \text{heart rate (bpm)} \times \text{stroke volume (mL)}$$

(note: bpm means beats per minute)

The heart rate is the speed at which the heart beats, and the amount of blood pumped by the left ventricle in one compression is called the stroke volume.



L-Università
ta' Malta

MATRICULATION AND SECONDARY EDUCATION CERTIFICATE
EXAMINATIONS BOARD

**ADVANCED MATRICULATION LEVEL
2023 FIRST SESSION**

SUBJECT: **Biology**
PAPER NUMBER: IV – *Practical*
DATE: 9th June 2023
TIME: 1 hour 35 minutes

Directions to Candidates

- Write your index number in the space at the top left-hand corner of this page.
 - Answer **ALL** parts of the question. Write all your answers in this booklet. Drawings of biological material and graphical representations of data are to be made on the appropriate pages within this booklet.
 - The marks allotted to parts of question are indicated.
 - You are reminded of the necessity for good English and orderly presentation in your answers.
 - In calculations you are advised to show all the steps in your working, giving your answer at each stage.
 - The use of electronic calculators is permitted.
-

For examiners' use only:

Question	Total
Score	
Maximum	40

1. Citric acid is naturally found in several plant species, especially citrus fruits such as grapefruit, lemon and orange. Scientific studies show that citric acid may slow down the formation of kidney stones in humans. Therefore, there are health benefits in knowing the concentration of this acid in certain food products.

One way of determining the concentration of citric acid in citrus fruit juices is through the use of alkaline phenolphthalein indicator. Citric acid decolourizes this indicator, changing it from pink to colourless.

For this experiment you are required to devise and implement an experimental procedure to compare the concentration of citric acid in different types of fruit juices.

You are provided with the following materials:

- a. alkaline phenolphthalein indicator;
- b. a solution containing 15 mg/cm³ citric acid;
- c. grapefruit juice;
- d. lemon juice;
- e. orange juice;
- f. other laboratory apparatus as required.

Candidates are advised to use 1 cm³ of the fruit juice samples provided during this experiment.

- a. State the aim of your biological investigation.

(1)

- b. Suggest suitable null hypothesis for this investigation.

(1)

d. List and justify **TWO** precautions that should be taken during the experiment.

Precaution 1: _____

Precaution 2: _____

_____ (4)

Carry out the investigation that you devised in part (c) and record your results in part (e).

e. Devise and compile a suitable table for recording your results. Use the space below for the results table. *Marks will be awarded for the structure and the organisation of the results obtained.*

--

(6)

f. One of the solutions provided contains 15 mg of citric acid in 1 cm³. Using this information, calculate the concentration of citric acid (in mg/cm³) for each of the three juices investigated during this experiment.

(i) grapefruit juice

(2)

(ii) lemon juice

(2)

(iii) orange juice

(2)

g. Using the graph paper provided on the following page, draw a graph to represent your results. (6)

Please turn the page.

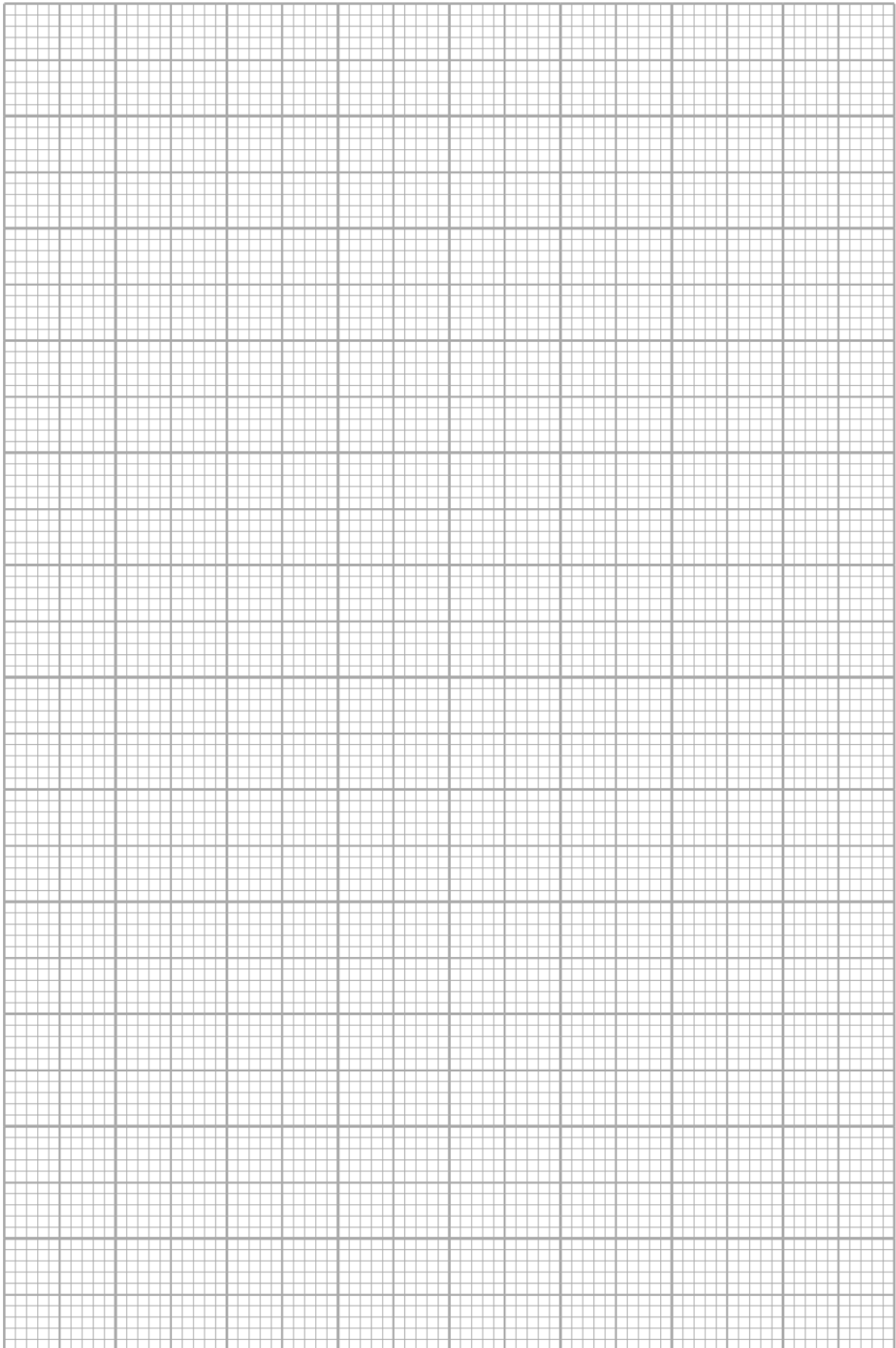

h. What conclusions can be drawn from your results?

(3)

i. List **TWO** sources of error in your investigation.

Source of error 1: _____

Source of error 2: _____

(2)

(Total: 40 marks)

Blank Page