

AM 09/I.12m – AM 15/I.12m

MATRICULATION AND SECONDARY EDUCATION CERTIFICATE EXAMINATIONS BOARD

UNIVERSITY OF MALTA, MSIDA

**MATRICULATION CERTIFICATE EXAMINATION
ADVANCED LEVEL
MAY 2012**

SUBJECT:	ENGINEERING DRAWING / GRAPHICAL COMMUNICATION
PAPER NUMBER:	I
DATE:	7th May 2012
TIME:	9.00 a.m. to 12.00 noon

Directions to Candidates

Write your index number where indicated at the top of all drawing sheets.

Attempt **any FIVE** questions.

Programmable calculators **cannot** be used.

Unless otherwise stated:

- a. drawings should conform to B.S. or equivalent (ISO) standards;
- b. all dimensions are in millimetres;
- c. all answers are to be accurately drawn with instruments;
- d. unless otherwise stated, all construction lines must be left in each solution;
- e. drawing aids may be used.

Dimensions not given should be estimated.

Careful layout and presentation are important.

Marks will be awarded for accuracy, clarity and appropriateness of constructions.

Mark allocations are shown in brackets.

Question 1

A Table Football tournament trophy has the form of a table football player. The base of the trophy is a hemisphere cut by two separate planes. The cut at the bottom provides a stable footing, whereas the cut on the side provides space for the nameplate of the trophy.

- i) Construct an isometric scale covering full-scale lengths up to 100mm. (2 marks)
 - ii) Copy the given projections of the trophy base **using isometric measurements** and complete the plan. (8 marks)
 - iii) **Project** isometrically the trophy base. Orientate your view such that point A occurs at the topmost point. **Hidden detail is required.** (10 marks)
- (20 marks total)**

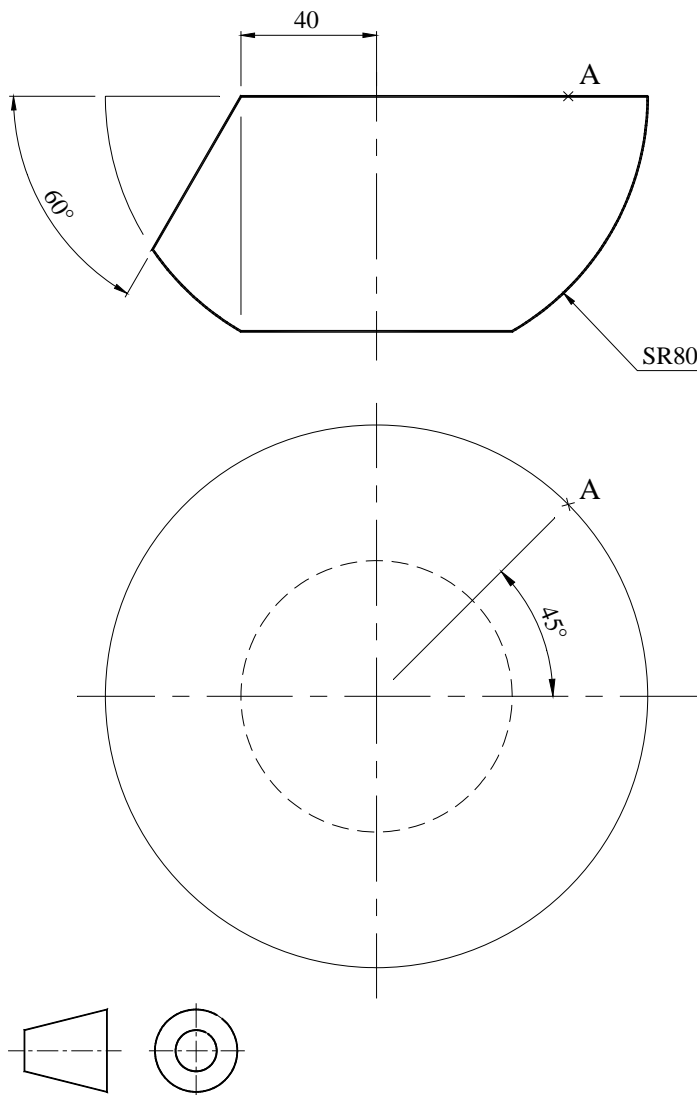

Question 2

A bar of rectangular cross-section is turned on a lathe to form a round bar having the greatest possible diameter. One end is radiused off to a bell-shape to obtain the palm-ended rod described below.

The rod is arranged so that the palmate section shows up truly in an auxiliary elevation.

i) Copy the given orthographic views. (2 marks)

ii) Derive the palmate section looking on X_1Y_1 . (8 marks)

iii) Deduce the ordinary elevation looking on XY . (10 marks)

(20 marks total)

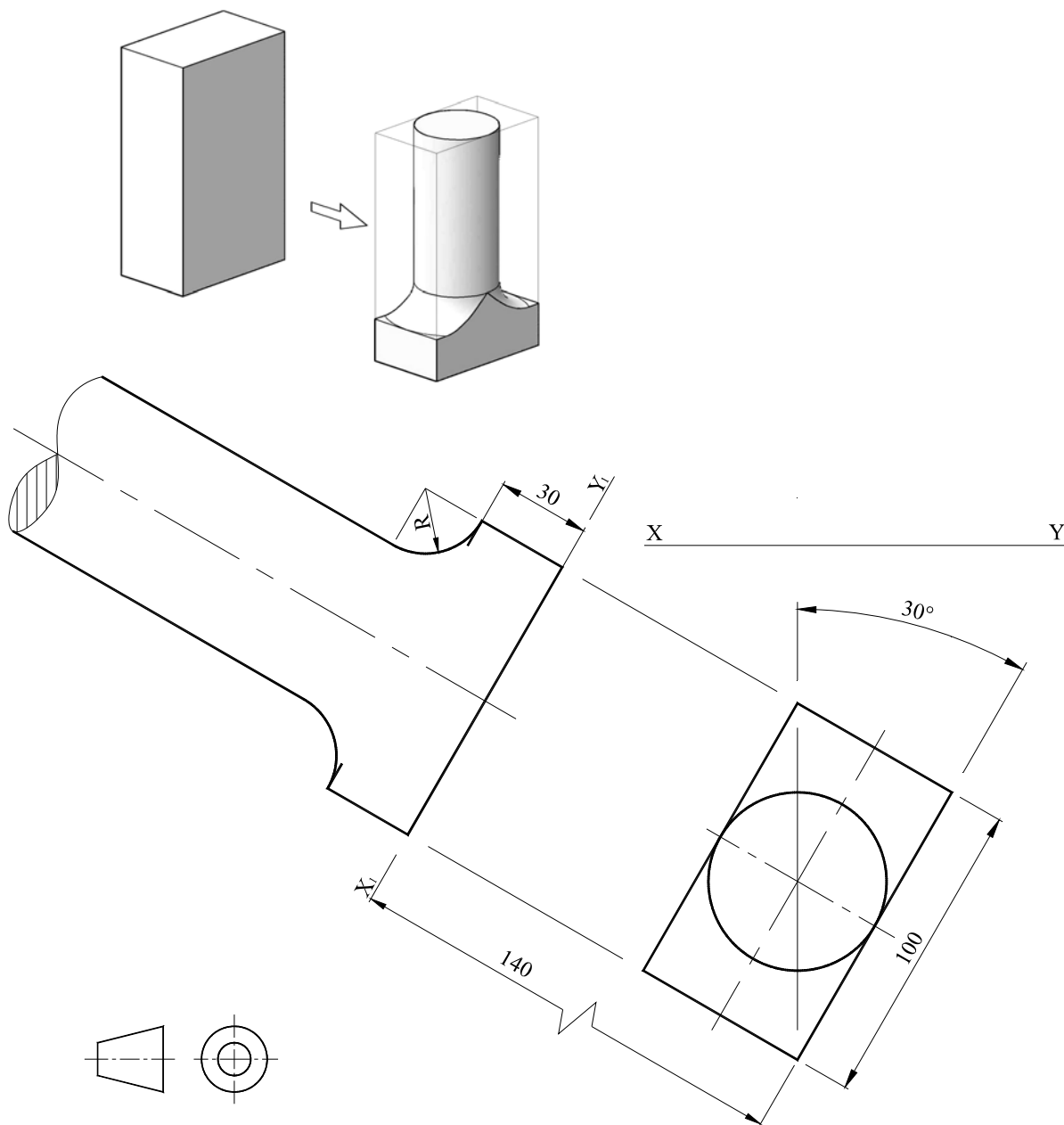

(Please turn the page)

Question 3

The figures below on the left, represent a matched pair of male and female threads. Figure 3.1 shows a common external 60° vee thread whereas Figure 3.2 represents a corresponding internal thread cut out of a block of metal.

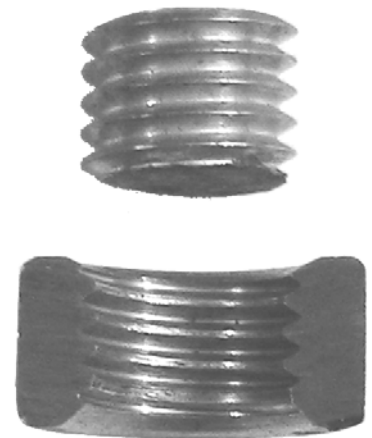

In a similar way and according to the scheme given in Figure 3.3, draw a matched pair of square threads having the following specifications:

- Pitch of thread = 24mm
- Major diameter = 110mm
- Hand of thread = Left
- No. of starts = 2

Hidden detail may be left out.

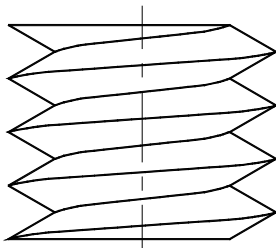
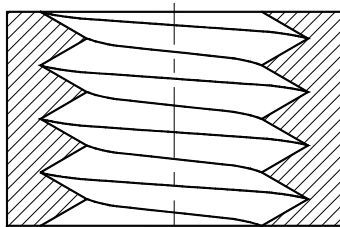

Figure 3.1



SECTION Y - Y

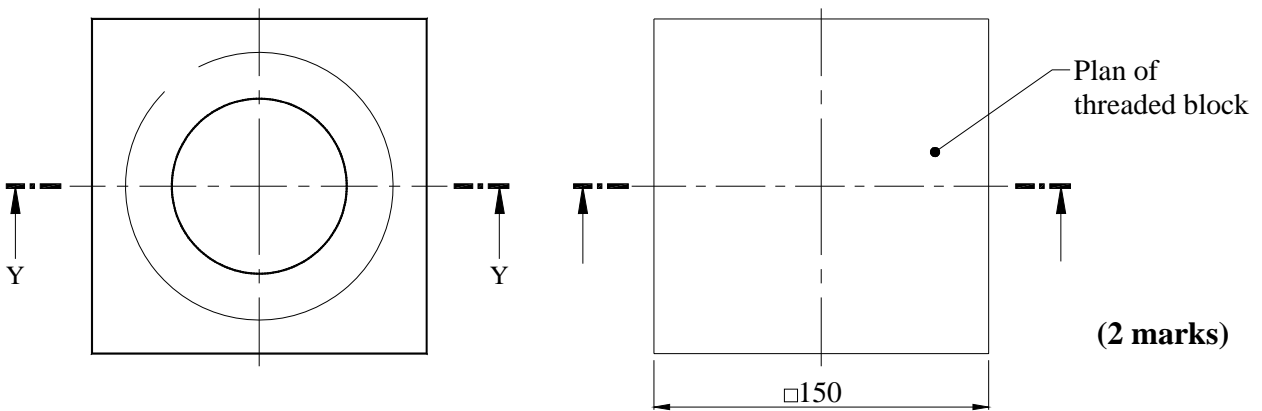
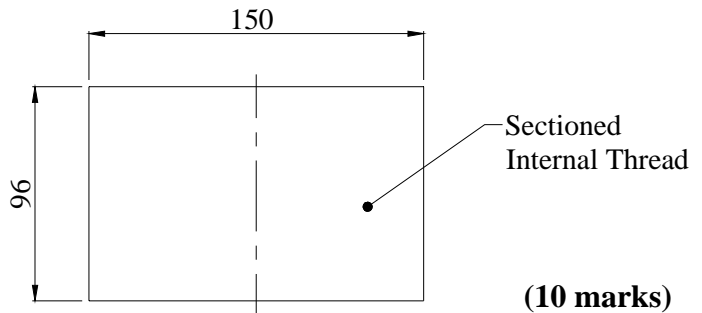
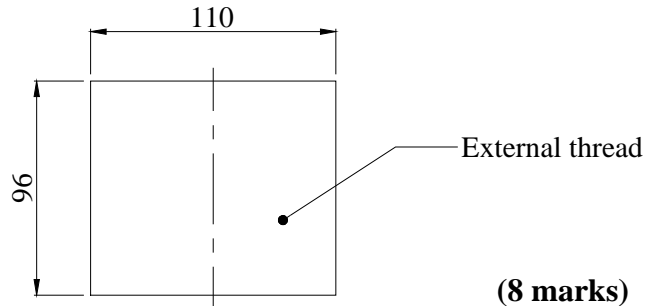
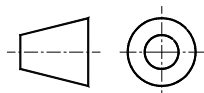

Figure 3.2

Figure 3.3



(20 marks total)

Question 4

- a) Figure 4.1 represents an oblique plane VTH and two lines AB and BC. Using the technique of auxiliary projection, determine:
- i) the angle the oblique plane makes with the HP. Record the angle to the nearest degree. **(2 marks)**
 - ii) whether each of the lines intersect with the oblique plane. If intersection does occur, locate the points of intersection in the plan and front elevation. **(2 marks)**
- b) A third line CA is introduced such that the 3 lines now represent the edges of a triangular plane ABC. Find the line of intersection that results between the plane ABC and the oblique plane VTH, updating the plan and front elevation accordingly. **(4 marks)**
- c) A tetrahedron (triangular pyramid) is formed by assuming a vertex D and joining to each corner of plane ABC, Figure 4.2. The oblique plane VTH cuts through the tetrahedron. Assuming a solid tetrahedron, deduce the plan and elevation of the part tetrahedron that lies below the plane VTH. **(12marks)**
(20 marks total)

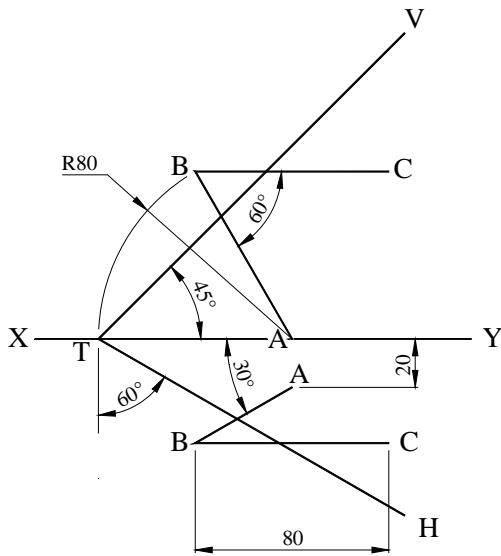

Figure 4.1

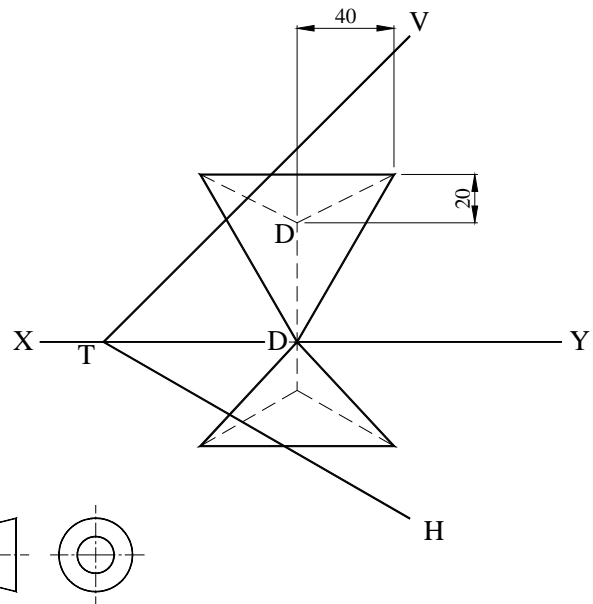
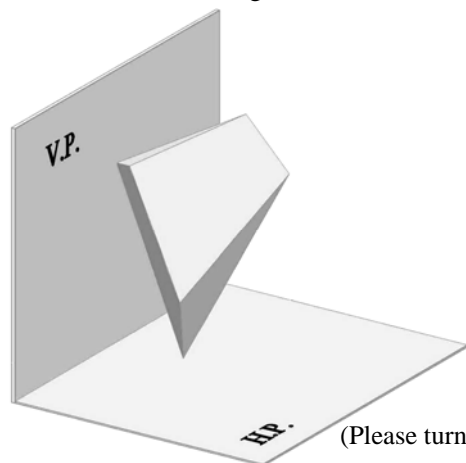
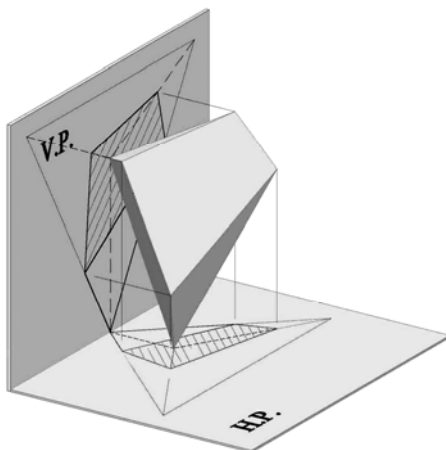

Figure 4.2



(Please turn the page)

Question 5

A simple spur gear train is required to provide a speed reduction of 1.5:1. The driven wheel must rotate in the **same** direction as the driving pinion. This is achieved by employing an idler gear having the same size as the pinion. The 3 gears are coplanar and also share the same horizontal plane passing through their centres. If the **overall** centre distance equals 144mm and the wheel has 12 teeth, find the value of the module to be used by the gear train.

(8 marks)

To a scale of 2:1 draw the two gears that will bring about the required gear ratio. You must show two consecutive meshing teeth of each gear. The gears use a pressure angle of 20° and the teeth are of involute form.

(12 marks)

One tooth of each gear must be drawn using the true involute form, whereas the other may be constructed using approximate geometric methods. The calculations made must be neatly printed and the derived data presented in table form.

(20 marks total)

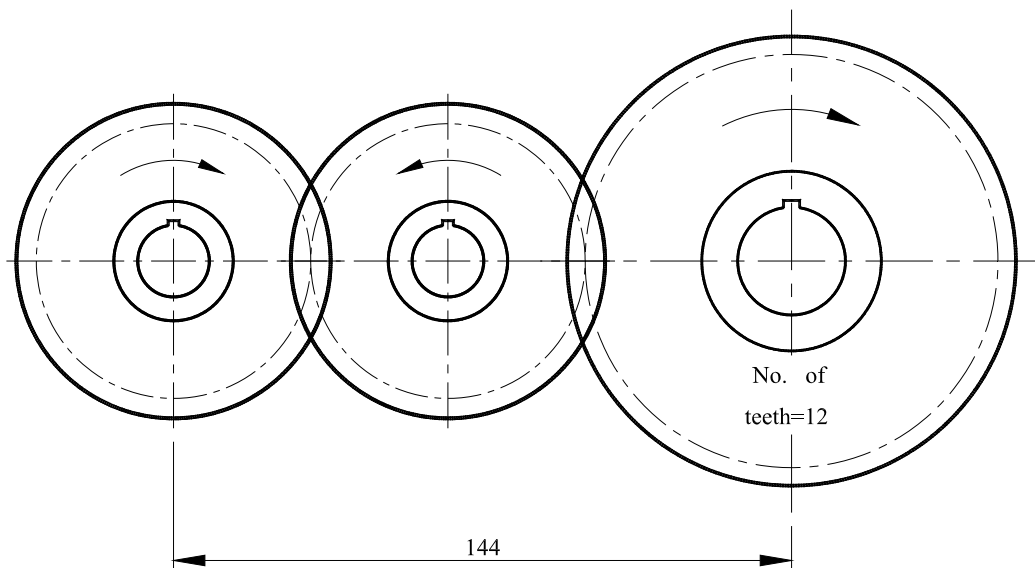

Question 6

Figure 6.1 represents a simplified beam model of the real-life structure shown in Figure 6.2. The beam carries two uniformly distributed loads and a point load as indicated.

Using a space diagram scale of 10mm representing 0.5m, a force diagram scale of 10mm representing 10kN and a polar distance of 50mm, determine graphically:

- i) the magnitudes of the reactions R_L and R_R ; **(8 marks)**
- ii) the shear force diagram; **(4 marks)**
- iii) the bending moment diagram; **(4 marks)**
- iv) the magnitude, position and nature (i.e. whether sagging or hogging) of the maximum bending moment. **(4 marks)**

(20 marks total)

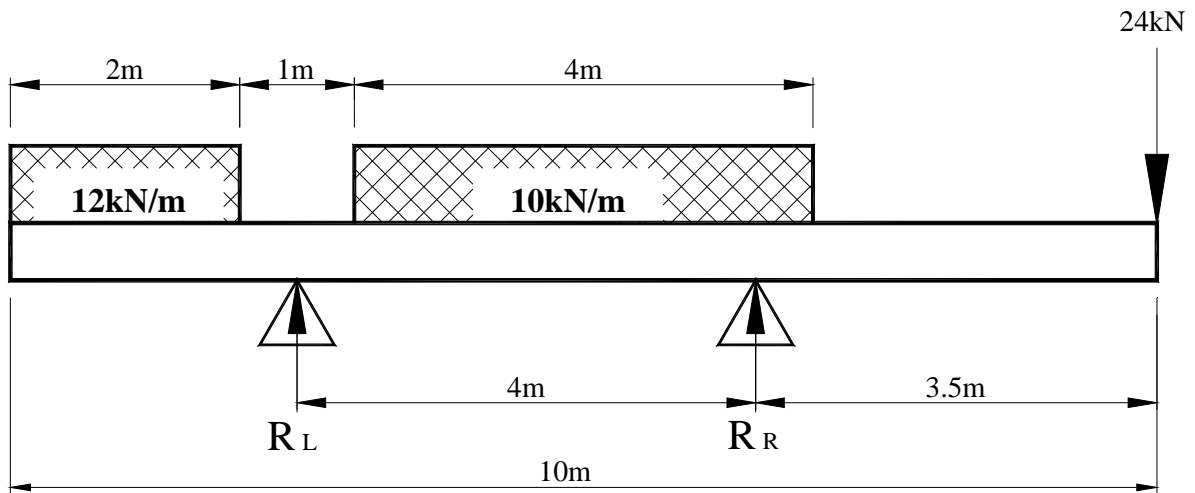

Figure 6.1

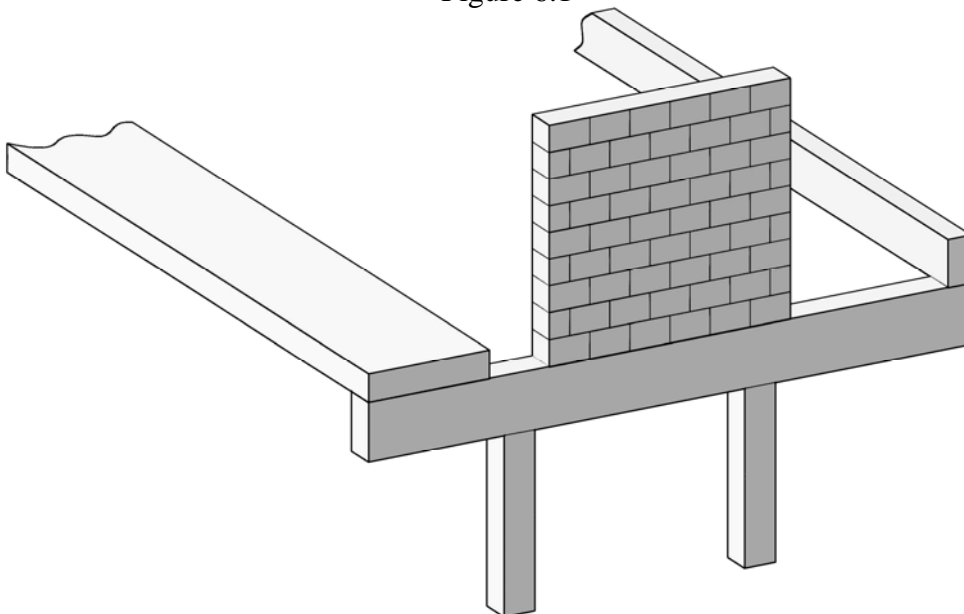

Figure 6.2

End of examination paper

MATRICULATION AND SECONDARY EDUCATION CERTIFICATE EXAMINATIONS BOARD

UNIVERSITY OF MALTA, MSIDA

MATRICULATION CERTIFICATE EXAMINATION
ADVANCED LEVEL
MAY 2012

SUBJECT:	ENGINEERING DRAWING
PAPER NUMBER:	II
DATE:	8th May 2012
TIME:	9.00 a.m. to 12.00 noon.

Directions to Candidates

Write your index number where indicated at the top of all drawing sheets.

Attempt **question 1** and any other **TWO** questions.

Programmable calculators **cannot** be used.

Unless otherwise stated:

- a. drawings should conform to BS or equivalent ISO standards;
- b. all dimensions are in millimetres;
- c. all answers are to be accurately drawn with instruments;
- d. all construction lines must be left on each solution;
- e. drawing aids may be used.

Dimensions not given should be estimated.

Careful layout and presentation are important.

Marks will be awarded for accuracy, clarity and appropriateness of constructions.

Mark allocations are shown in brackets.

Question 1 carries 60 marks. Questions 2, 3 and 4 carry 20 marks each.

Data sheet 4500A is supplied for use with question 2.

Question 1

Figure 1.1 shows a tailstock along the bed of a lathe. The tailstock is an essential component of any lathe of appreciable size. It provides the support necessary for the true turning of long components.

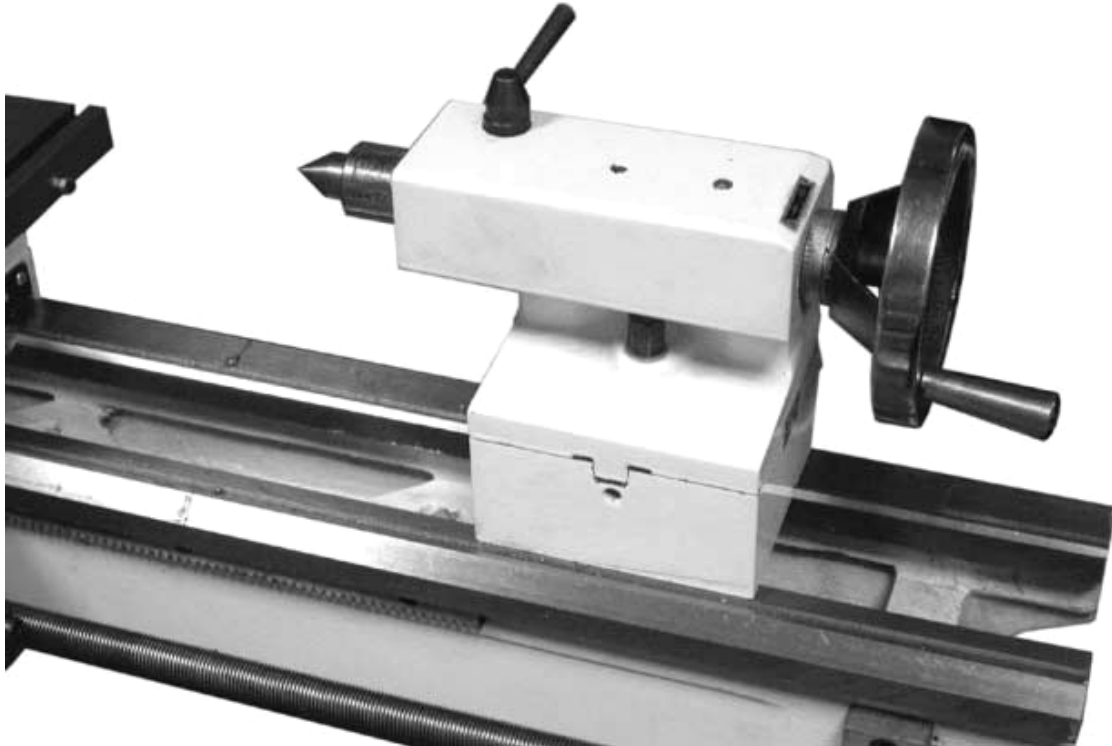

Figure 1.1

Figure 1.2 and Figure 1.3 describe the details of 11 parts making up the design of a similar tailstock.

The main body (Part 1) houses the barrel (Part 2) in its $\text{Ø}35$ bore. The barrel is displaced longitudinally by the action of a left-handed leadscrew (Part 3) which engages in its rear threaded part. The leadscrew is driven by a handwheel (Part 4). The handwheel is secured to the leadscrew using a square key (Part 5), plain washer (not shown) and an M12 standard nut (not shown).

Clockwise rotation of the handwheel drives the barrel out from the tailstock's body. Anticlockwise rotation retracts the barrel as the leadscrew advances forward inside it. The leadscrew can only rotate as its position is 'locked' between the endcap (Part 6) and the handwheel. The leadscrew is supported by the female thread in the barrel and the bush (Part 7) fitted in the endcap.

A dead centre (Part 8) is installed in the front ('Morse') tapered hole of the barrel. On installation, Face B of the barrel coincides with the vertical plane C of the dead centre. Continued anticlockwise handwheel rotation gets the leadscrew to thrust against the dead centre and cause its eventual ejection.

AM 09/II.12m

The barrel is prevented from turning by a special key (Part 9) housed within the tailstock's body and which projects into the keyway cut along the barrel. The key is installed from within the $\text{\O}35$ bore of the main body. The barrel is secured in any position by the action of a locking handle (Part 10), which turns a pin (Part 11), which thrusts on the special key, which in turn presses on the barrel preventing it from moving.

Consider the parts of the tailstock assembled together, with the leadscrew just touching the dead centre and the locking handle (Part 10) lying parallel to the axis of the barrel.

Draw full size, in either first or third angle orthographic projection, the following views:

- i) a sectional front elevation of the complete setup, on the vertical plane A-A. *Employ local (part) sections when treating the square key in the leadscrew and the male thread on the handle (Part 10). Show the M12 hexagonal nut in the 'across corners' position;* **(45 marks)**
- ii) a half end elevation as seen when looking on the dead centre. *Make use of the right convention used with partial views of symmetrical parts.* **(15 marks)**

Insert on your drawing the symbol for the orthographic projection used.

Do not include hidden detail.

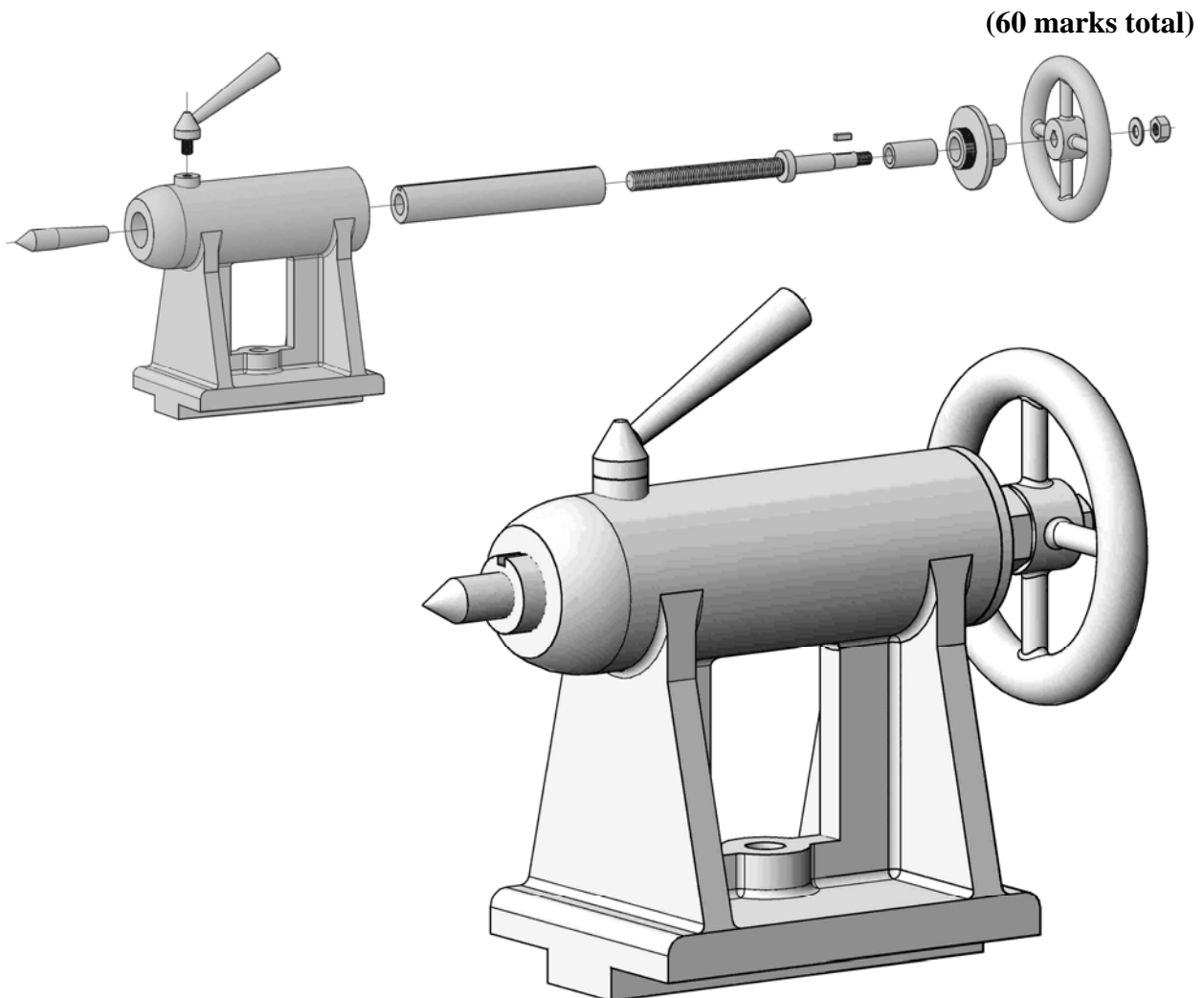

(Please turn the page)

Question 2

- i) Up to the end of the 19th century, engineering mating parts were manufactured individually and had to be **fitted** one to the other. Nowadays, similar parts mass-produced in different parts of the world can be interchanged, and mating parts may be **assembled** with a predictive assurance that they will function satisfactorily together.

What systems are modern engineering firms using to achieve such standards? **(1 mark)**

- ii) The Data sheet 4500A provided gives a set of 10 selected fits. In each case the tolerance zone of the hole sits on the zero line.

- a) What does ‘the tolerance zone of the hole sits on the zero line’ imply? **(1 mark)**
 b) What does the zero line represent? **(1 mark)**
 c) In each case, what is the value of the hole fundamental deviation? **(1 mark)**

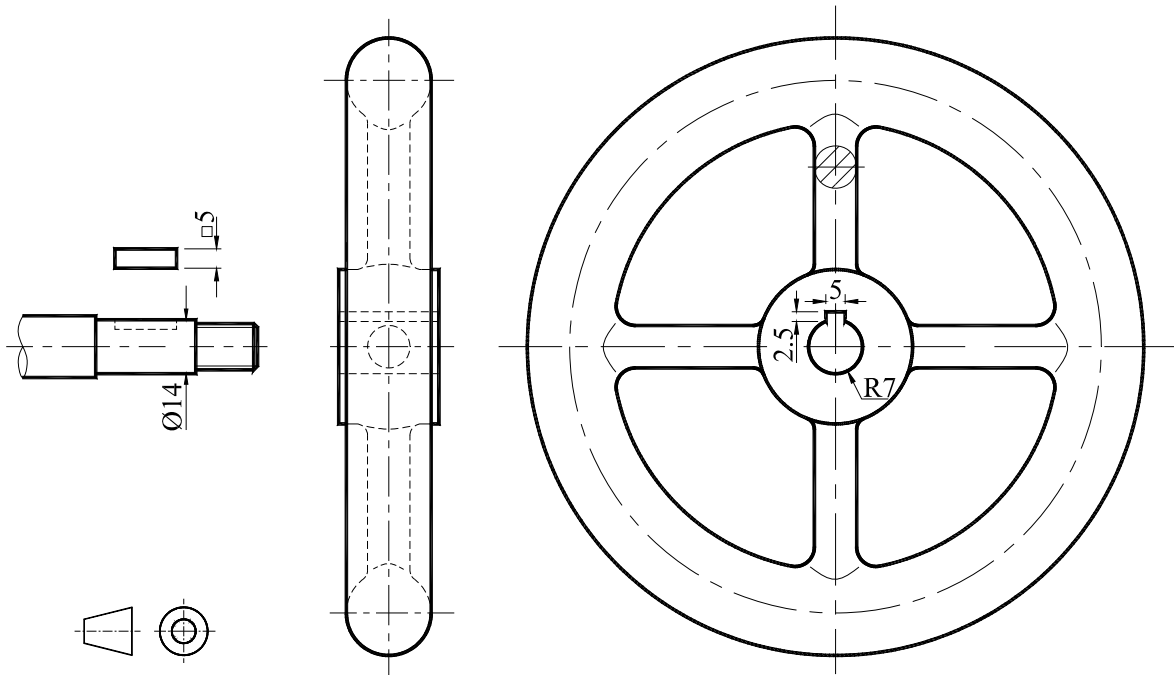

Figure 2

- iii) Besides cylindrical surfaces, Data sheet 4500A applies equally well to keys and shaft keyseats and keys and hub keyways. Figure 2 shows part of a spindle, a key and a handwheel. The key secures the handwheel to the spindle. The fit of the 5x5 square key in relation to its seat in the spindle is specified as H7/k6.

- a) What class of engineering fit is H7/k6? **(1 mark)**
 b) Find the limits of size for the widths of both the key and the keyseat. **(2 marks)**

AM 09/II.12m

- c) Determine the maximum interference and maximum clearance that can result between the mating surfaces. **(2 marks)**

Support your calculations by a sketch showing the tolerance zones, appropriately arranged relative to the basic size, labelled also by the limits of size. (2 marks)

Using verbal description which of the following terms would best describe the fit H7/k6?

‘push fit’

‘heavy press fit’

‘loose fit’

(1 mark)

- iv) In Figure 2, the key has a **close clearance fit** in the keyway cut in the handwheel. The fit has to provide a minimum clearance that is greater than 0.007mm and a maximum clearance less than 0.05mm. Make the necessary calculations to select a suitable fit.

(6 marks)

Support your calculations by sketches showing the tolerance zones, appropriately arranged relative to the basic size, labelled also by the limits of size. (2 marks)

(20 marks total)

Candidates are expected to use the Data Sheet 4500A provided to answer this question.

(Please turn the page)

Question 3

A craftsman requires a half-round pedestal support which he can slide and secure at any position along the bed of his custom-made woodwork lathe. He proposes the design described pictorially in Figure 3.1 and Figure 3.2 and decides to fabricate it using welding from pieces of thick flat bar and circular hollow sections.

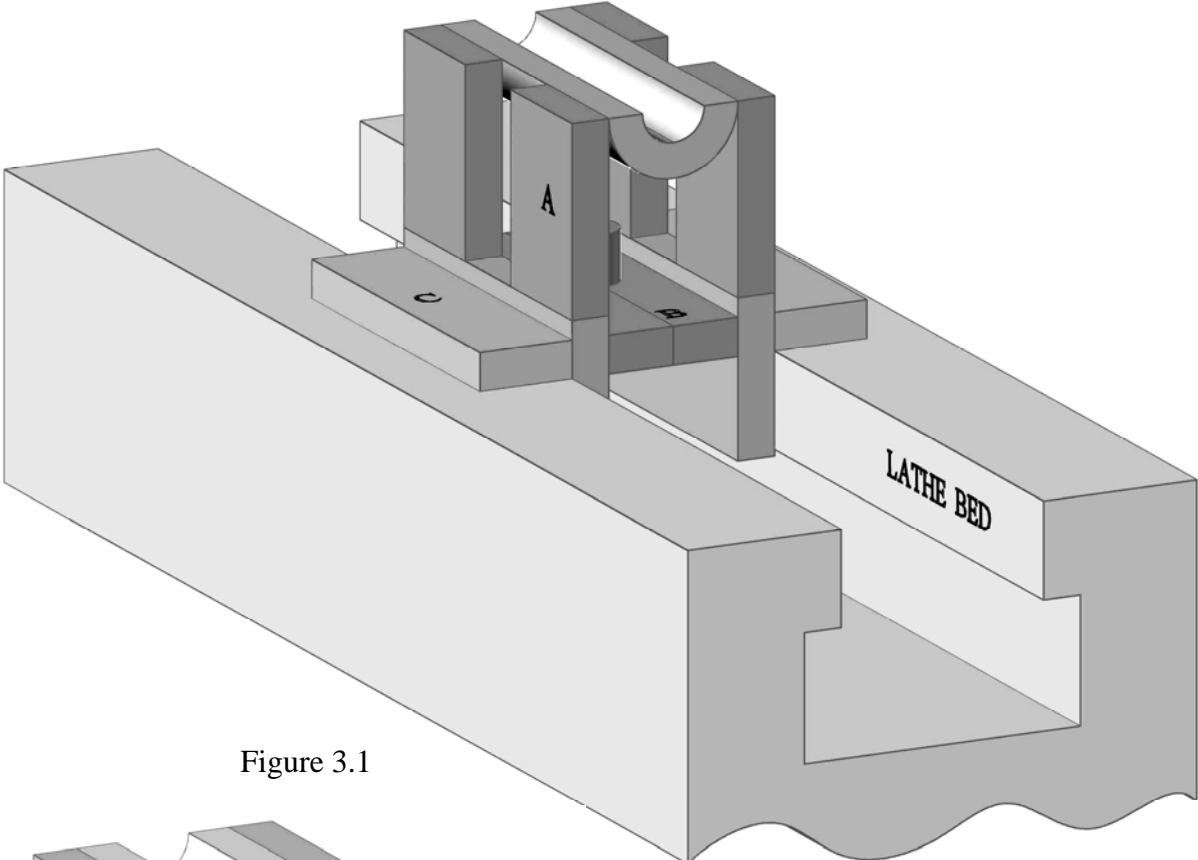

Figure 3.1

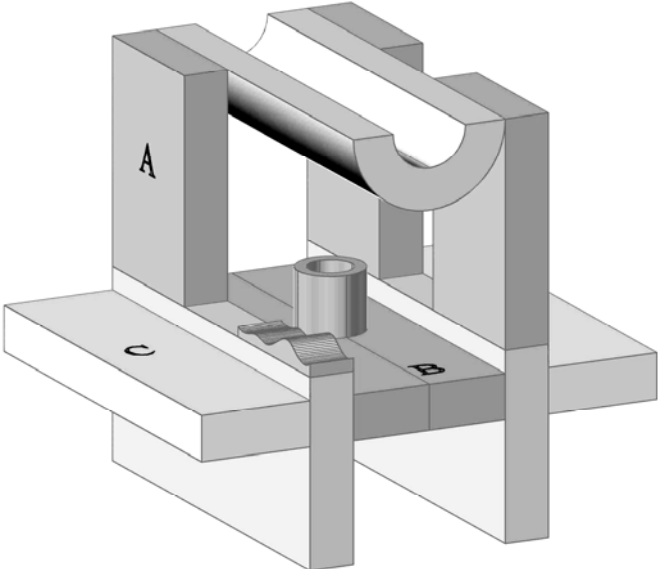

Figure 3.2

The uprights, A, are formed from 3 pieces of flat bar arranged in the form of a U-shape as shown in Figure 3.3. These are joined by *double vee butt* welds, with the material deposited being *ground flush* with the original surface of the flat bar.

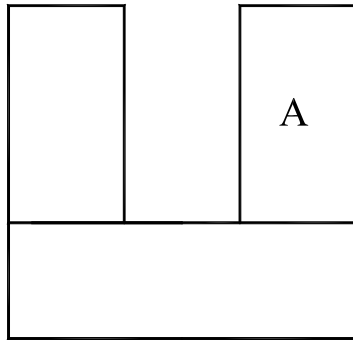

Figure 3.3

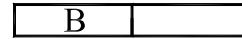

Figure 3.4

The middle horizontal plate, B, is made up from 2 identical pieces of flat bar welded together using *double U butt* welds, Figure 3.4. The weld on the top surface is *ground flush*.

The plate thus obtained is suitably bored (drilled) at its centre to accommodate snugly a short length of circular hollow section (CHS) as shown in Figure 3.5. With the smooth ground joint of the plate facing up, a continuous fillet weld is placed *all around* the CHS, on either side of the plate. The weld on the top surface is *finished to a concave profile*.

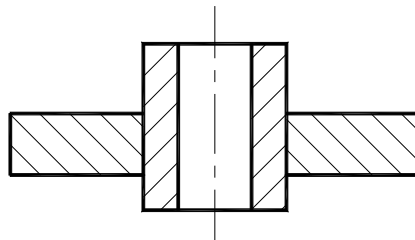

Figure 3.5

The overhangs C simply consist of pieces of flat bar.

The two uprights, the middle plate (and its central boss) and the overhangs are now arranged as shown in Figure 3.6 and joined by placing fillet welds along the corners ①, ②, ③, ④, ⑤ and ⑥. *Concave finishes* are applied only to the welds at ①, ②, ③ and ④.

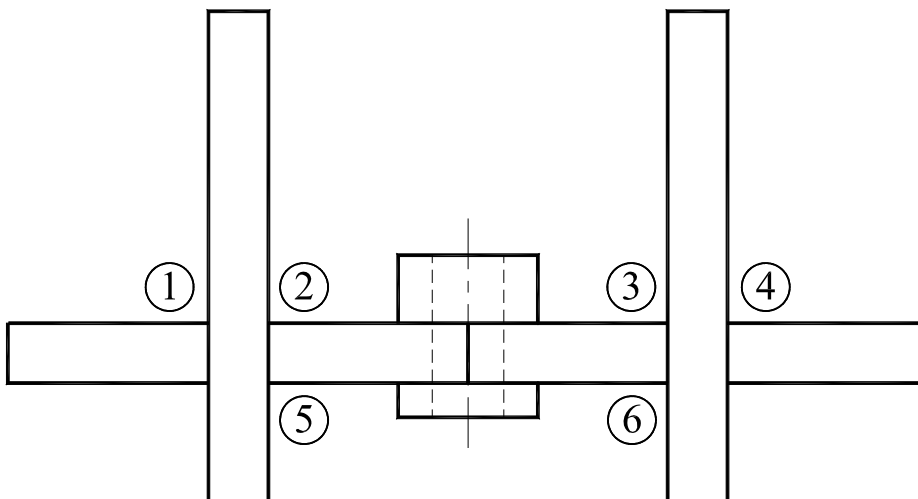

Figure 3.6

(Please turn the page)

Finally the right length of a suitable half-round section is welded across the two uprights as in Figure 3.7. Two welds, one on either side, are used. The weld used is similar to a butt weld but since it actually joins two edges, the weld is in fact called an *edge weld*. The weld fuses the top edge of each upright with one edge of the half-round section. Figure 3.8 gives a pictorial description of an edge weld and its corresponding BS symbol.

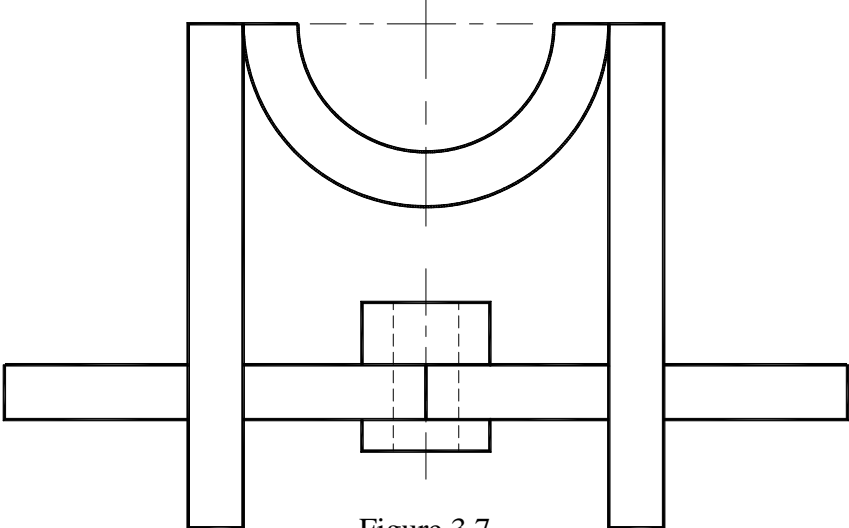
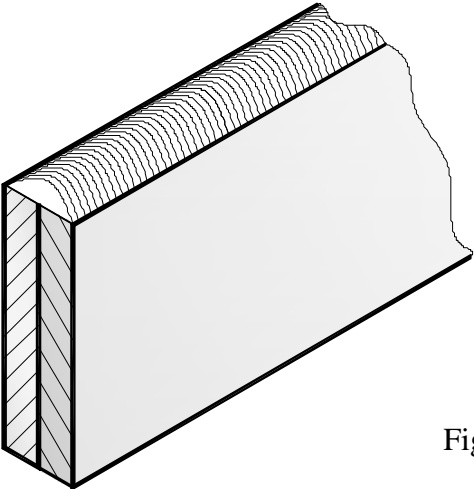

Figure 3.7



B.S. Symbol for edge weld

Figure 3.8

Make good proportionate sketches of Figure 3.3, Figure 3.4, Figure 3.5, Figure 3.6 and Figure 3.7 and on each attach the appropriate welding symbol at the joints concerned. Where appropriate, the welds on the 'other side' of the joint should be represented using methods explained in BS EN 22553:1995.

(20 marks total)

Question 4

You are a student teacher of Engineering Drawing faced with the task of teaching your students the following types of sectional views:

- i) half-section; **(4 marks)**
- ii) part (local) section; **(3 marks)**
- iii) revolved section; **(3 marks)**
- iv) section staggered across two or more parallel planes; **(5 marks)**
- v) section bent through an angle. **(5 marks)**

Using third angle orthographic projection, produce for each case, suitable diagrams that will help explain the kind of section and its specific convention. Your work should also depict the standard general practices associated with sectioning, like the proper representation of cutting planes and the proper use of hatching lines. The examples used should be clear and simple, yet sufficiently representative of the kind of section.

(20 marks total)

End of examination paper

BRITISH STANDARD SELECTED ISO FITS—HOLE BASIS

Nominal sizes		Clearance fits										Transition fits				Interference fits				Nominal sizes			
		Tolerance		Tolerance		Tolerance		Tolerance		Tolerance		Tolerance		Tolerance		Tolerance							
Over	To	H11	c11	H9	d10	H9	e9	H8	f7	H7	g6	H7	h6	H7	k6	H7	n6	H7	p6	H7	s6	Over	To
mm	mm	0.001 mm	0.001 mm	0.001 mm	0.001 mm	0.001 mm	0.001 mm	0.001 mm	0.001 mm	0.001 mm	0.001 mm	0.001 mm	0.001 mm	0.001 mm	0.001 mm	0.001 mm	0.001 mm	0.001 mm	0.001 mm	0.001 mm	0.001 mm	mm	mm
—	3	+60 0	-60 -120	+25 0	-20 -60	+25 0	-14 -39	+14 0	-6 -16	+10 0	-2 -8	+10 0	-6 0	+10 0	+6 +0	+10 0	+10 +4	+10 0	+12 +6	+10 0	+20 +14	—	3
3	6	+75 0	-70 -145	+30 0	-30 -78	+30 0	-20 -50	+18 0	-10 -28	+12 0	-4 -12	+12 0	-8 0	+12 0	+9 +1	+12 0	+16 +8	+12 0	+20 +12	+12 0	+27 +19	3	6
6	10	+90 0	-80 -170	+36 0	-40 -98	+36 0	-25 -61	+22 0	-13 -28	+15 0	-5 -14	+15 0	-9 0	+15 0	+10 +1	+15 0	+19 +10	+15 0	+24 +15	+15 0	+32 +23	6	10
10	18	+110 0	-95 -205	+43 0	-50 -120	+43 0	-32 -75	+27 0	-16 -34	+18 0	-6 -17	+18 0	-11 0	+18 0	+12 +1	+18 0	+23 +12	+18 0	+29 +18	+18 0	+39 +28	10	18
18	30	+130 0	-110 -240	+52 0	-65 -149	+52 0	-40 -92	+33 0	-20 -41	+21 0	-7 -20	+21 0	-13 0	+21 0	+15 +2	+21 0	+28 +15	+21 0	+35 +22	+21 0	+48 +35	18	30
30	40	+160 0	-120 -280	+62 0	-80 -180	+62 0	-50 -112	+39 0	-25 -50	+25 0	-9 -25	+25 0	-16 0	+25 0	+18 +2	+25 0	+33 +17	+25 0	+42 +26	+25 0	+59 +43	30	40
40	50	+160 0	-130 -290																			40	50
50	65	+190 0	-140 -330	+74 0	-100 -220	-74 0	-60 -134	+46 0	-30 -60	+30 0	-10 -29	+30 0	-19 0	+30 0	+21 +2	+30 0	+39 +20	+30 0	+51 +32	+30 0	+72 +53	50	65
65	80	+190 0	-150 -340																			65	80
80	100	+220 0	-170 -390	+87 0	-120 -260	-87 0	-72 -159	+54 0	-36 -71	+35 0	-12 -34	+35 0	-22 0	+35 0	+25 +3	+35 0	+45 +23	+35 0	+59 +37	+35 0	+93 +71	80	100
100	120	+220 0	-180 -400																			100	120
120	140	+250 0	-200 -450																			120	140
140	160	+250 0	-210 -460	+100 0	-145 -305	+100 0	-84 -185	+63 0	-43 -83	-40 0	-14 -39	+40 0	-25 0	+40 0	+28 +3	+40 0	+52 +27	-40 0	+68 +43	+40 0	+117 +92	140	160
160	180	+250 0	-230 -480																			160	180
180	200	+290 0	-240 -530																			180	200
200	225	+290 0	260 550	+115 0	-170 -355	+115 0	-100 -215	+72 0	-50 -96	+46 0	-15 -44	+46 0	-29 0	+46 0	+33 +4	+46 0	+60 +31	+46 0	+79 +50	+46 0	+151 +122	200	225
225	250	+290 0	280 570																			225	250
250	280	+320 0	300 620	+130 0	-190 -400	+130 0	-110 -240	+81 0	-56 -108	+52 0	-17 -49	+52 0	+32 0	+52 0	-36 +4	+52 0	+66 +34	+52 0	+88 +56	+52 0	+190 +158	250	280
280	315	+320 0	330 650																			280	315
315	355	+360 0	360 -720	+140 0	-210 -440	+140 0	-125 -265	+89 0	-62 -119	+57 0	-18 -54	+57 0	-36 0	+57 0	+40 +4	+57 0	+73 +37	+57 0	+98 +62	+57 0	+226 +190	315	355
355	400	+360 0	400 760																			355	400
400	450	+400 0	440 840	+155 0	-230 -480	+155 0	-135 -290	+97 0	-68 -131	+63 0	-20 -60	+63 0	-40 0	+63 0	+45 +5	+63 0	+80 +40	+63 0	+108 +68	+63 0	+272 +232	400	450
450	500	+400 0	480 880																			450	500

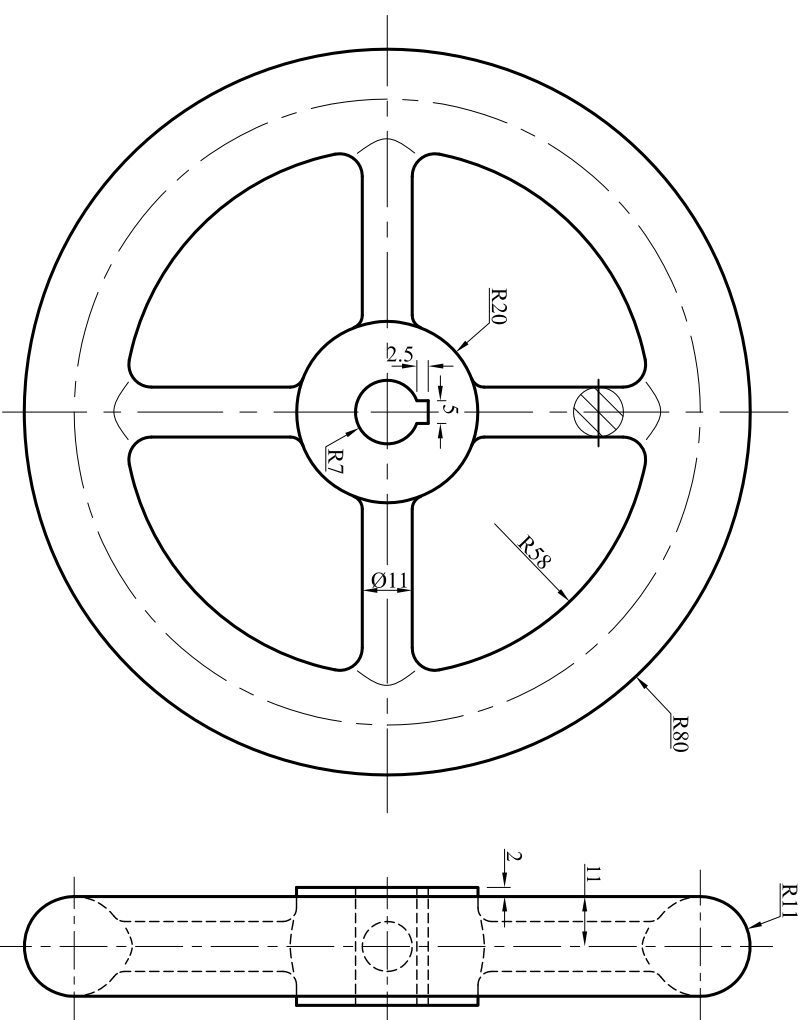

HANDWHEEL PART 4

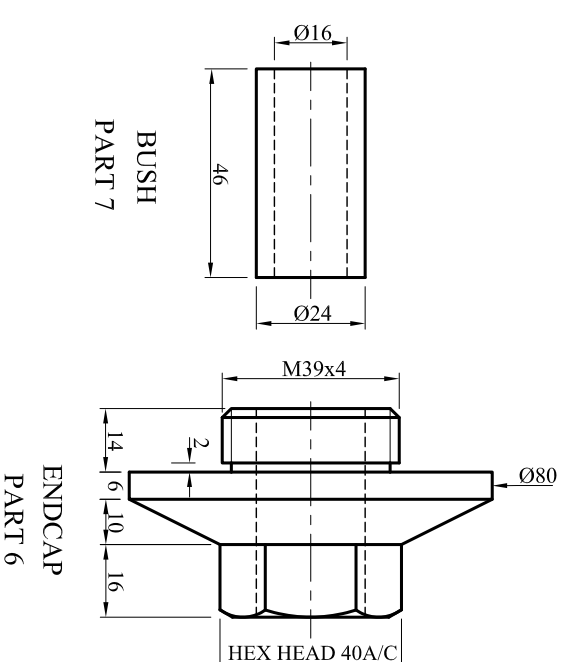

BUSH PART 7

ENDCAP PART 6

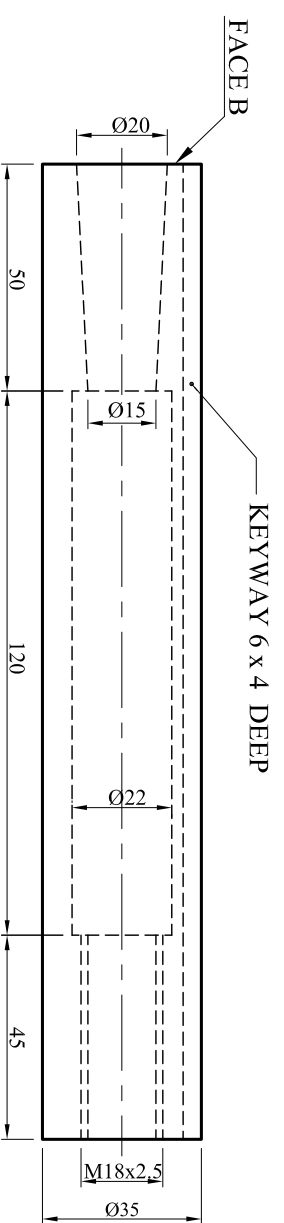

FACE B

KEYWAY 6 x 4 DEEP

BARREL PART 2

ON ASSEMBLY FACE B AND VERTICAL PLANE C COINCIDE

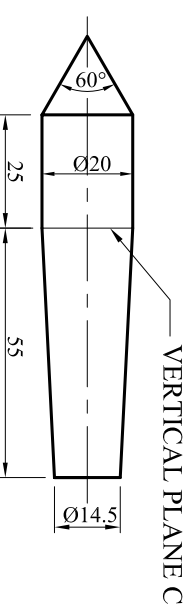

VERTICAL PLANE C

DEAD CENTRE PART 8

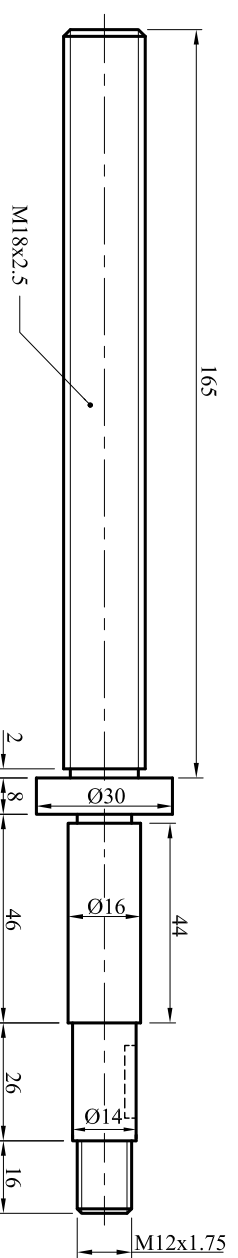

LEADSCREW PART 3

KEY PART 5

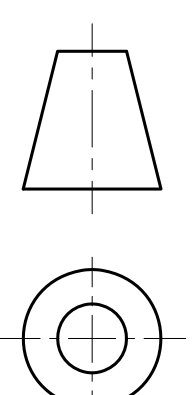
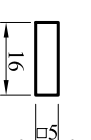

FIGURE 1.3

ALL FILLET RADII 4mm
UNLESS OTHERWISE STATED