

AM 09/I.13 m – AM 15/I.13m

MATRICULATION AND SECONDARY EDUCATION CERTIFICATE EXAMINATIONS BOARD

UNIVERSITY OF MALTA, MSIDA

**MATRICULATION CERTIFICATE EXAMINATION
ADVANCED LEVEL
MAY 2013**

SUBJECT:	ENGINEERING DRAWING / GRAPHICAL COMMUNICATION
PAPER NUMBER:	I
DATE:	7th May 2013
TIME:	9.00 a.m. to 12.00 noon

Directions to Candidates

Write your index number where indicated at the top of all drawing sheets.

Attempt **any five** questions.

Programmable calculators **cannot** be used.

Unless otherwise stated:

- a. drawings should conform to B.S. or equivalent (ISO) standards;
- b. all dimensions are in millimetres;
- c. all answers are to be accurately drawn with instruments;
- d. unless otherwise stated, all construction lines must be left in each solution;
- e. drawing aids may be used.

Dimensions not given should be estimated.

Careful layout and presentation are important.

Marks will be awarded for accuracy, clarity and appropriateness of constructions.

Mark allocations are shown in brackets.

Question 1

The illustrations show a cylinder, a cone and a sphere all resting on the horizontal plane and the resulting curves when the solids are cut by an oblique plane.

Figure 1 shows the position of the right cylinder and the right cone resting on the horizontal plane and parallel to the vertical plane. The apparent angle of the horizontal and vertical plane and the positions of the vertical and horizontal traces, VTH, are also included. A sphere is to be placed on the horizontal plane and in mutual contact with the cylinder and the cone. The sphere is to be placed in front of the other two solids so as to be completely visible in the elevation.

- Construct the plan and the elevation of the three solids in mutual contact with each other, showing the points of contact between the three solids;
- draw an auxiliary elevation showing the oblique plane as an inclined plane and the truncations of the three solids;
- construct an elevation and a plan of that part of the three solids which lie below the oblique plane.

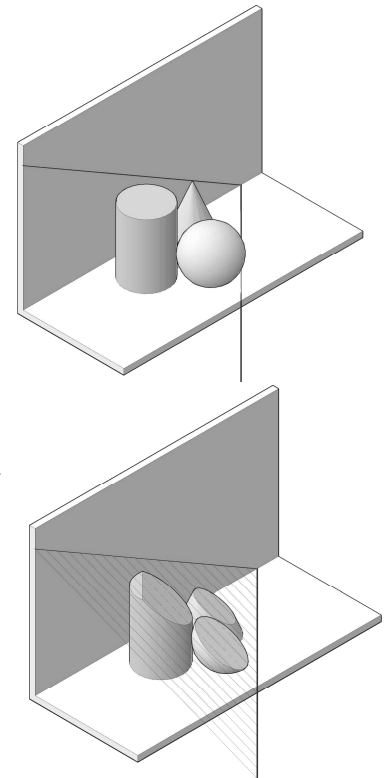

Show all hidden detail.

(20 marks)

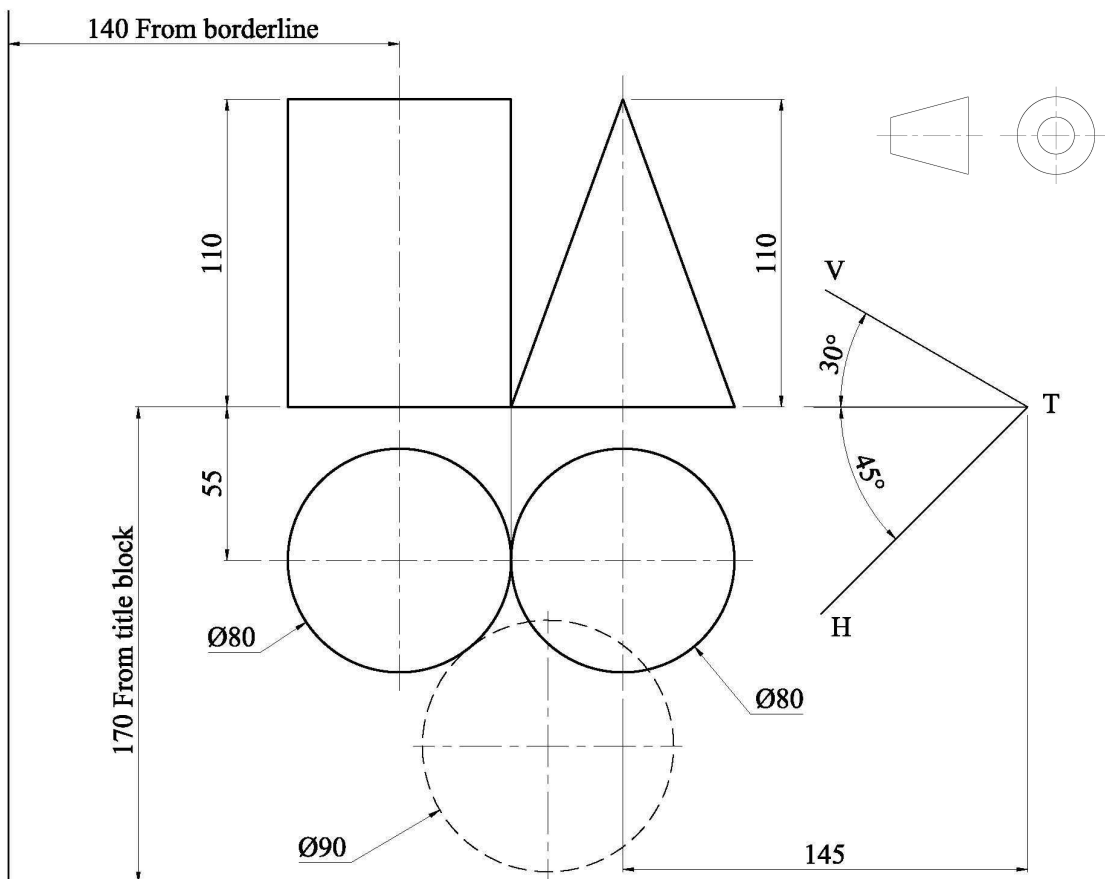
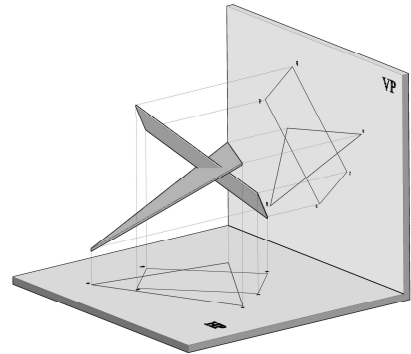

Figure 1

Question 2

Two plates are shown intersecting each other. The two incomplete views shown in Figure 2 describe the position of the triangular plate ABC and the rectangular plate PQRS.

- Copy, full size, the two given views as shown below;
- project an auxiliary elevation representing one of the plates as a straight line and the other plate as a normal projection;
- complete the elevation and a plan of the two plates showing the common line of intersection between the two plates;
- draw the true shape of the triangular plate and show the common line of intersection.



Show hidden detail.

(20 marks)

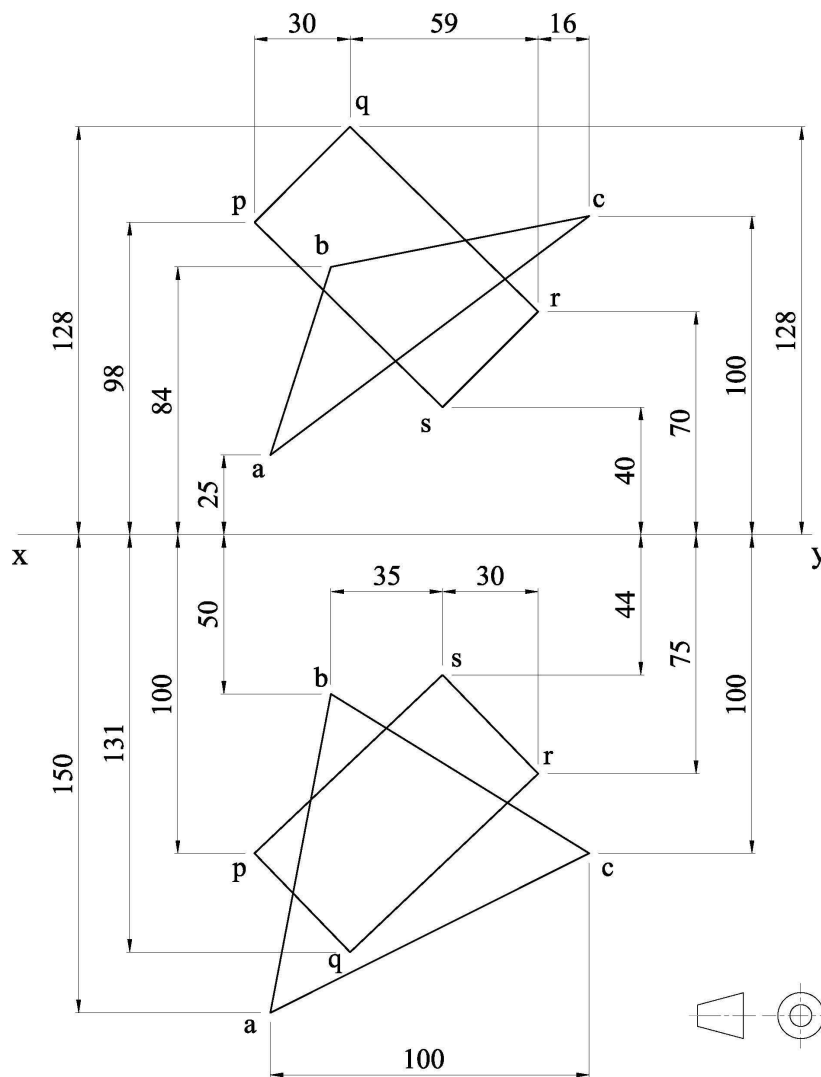
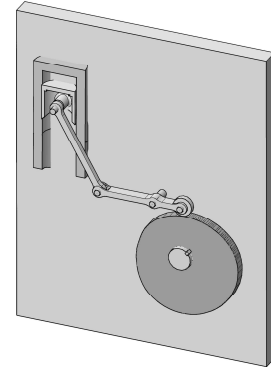

Figure 2

Question 3

The cam shown operates a radial arm roller-ended follower which is linked to a pivoted link and a guide block. The guide block in the mechanism shown reciprocates along the line X-Y by the rotation of the plate cam.



Using the dimensions shown in Figure 3, construct:

- a) a displacement diagram for the guide block during one revolution of the cam;

<i>Cam's angular displacement</i>	<i>Motion given to the block</i>
0° to 120°	The block is to move 68mm downwards with simple harmonic motion.
120° to 180°	The block is to remain stationary.
180° to 300°	The block is to return to its starting position with uniform acceleration and retardation motion.
180° to 360°	The block is to remain stationary.

- b) the cam profile which imparts motion to the roller-ended follower.

Note: The rotation of the cam is anti clockwise.

(20 marks)

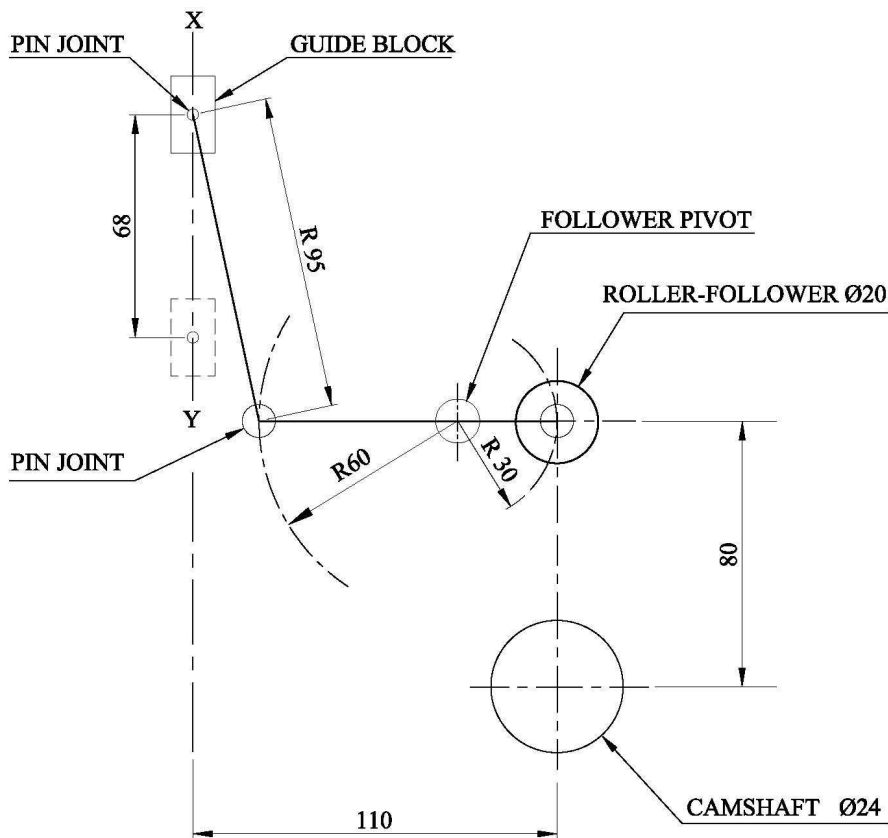
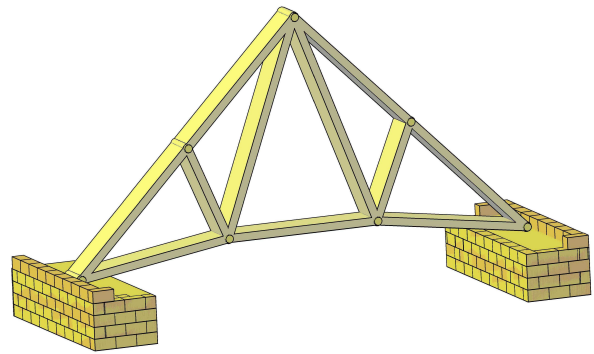

Figure 3

Question 4

The pin jointed structure shown in Figure 4 is simply supported at the left and right reactions.

- To a scale of 3mm representing 1 metre, draw the space diagram and the framework with the external forces, reactions and Bow's notation as shown in Figure 4;
- using a scale of 10mm representing 1kN, draw a force diagram to represent the external forces and a polar diagram;
- construct a link polygon to determine the magnitude of the left and right reactions;
- determine the magnitude of the forces in each member of the framework;
- present a table showing the magnitude of the various forces. State which members are in tension and which members are in compression.



(20 marks)

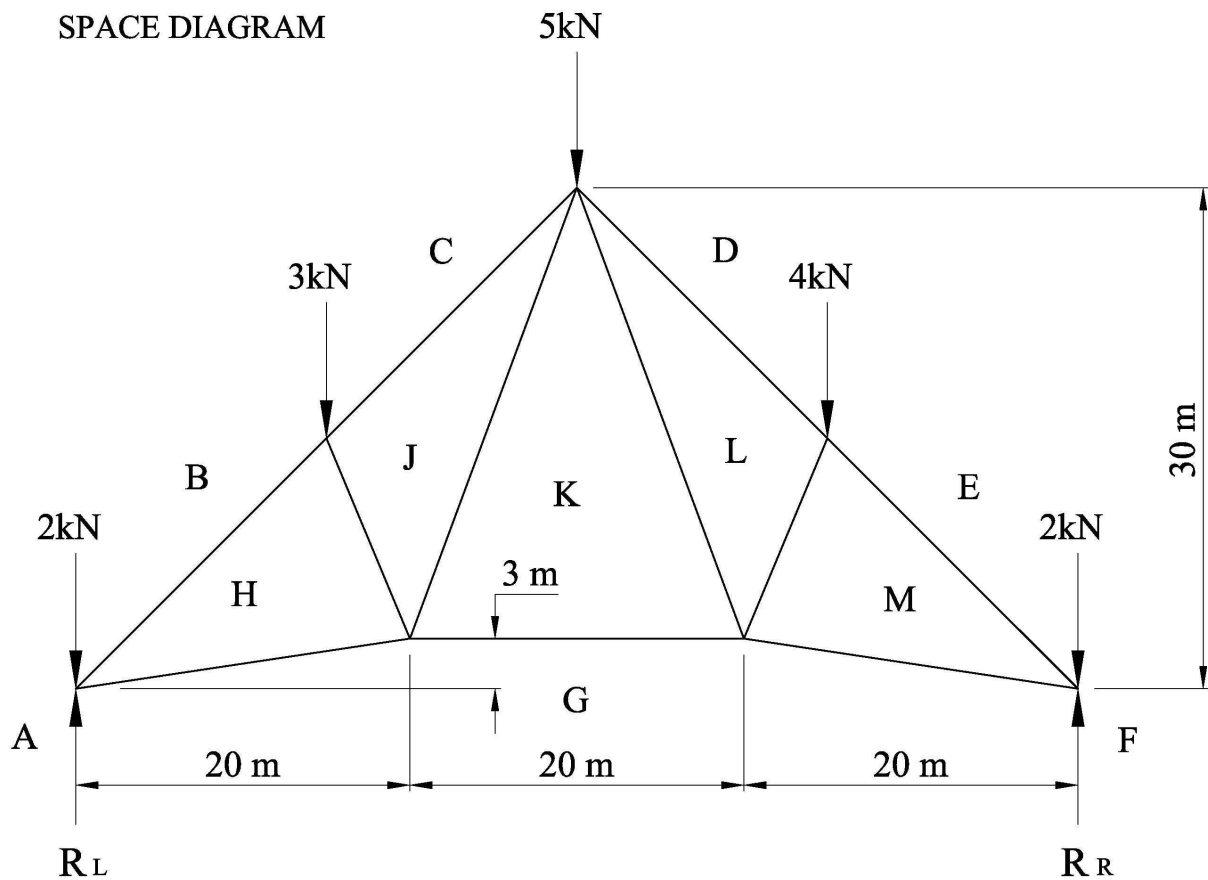
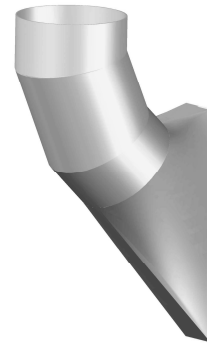

Figure 4

Question 5

The 3-D illustrations represent a transformer connection from a vertical rectangular hole to the segment of a lobster-back bend. For the purpose of development, the projection below presents the circle horizontal and the base inclined. The dimensions of the transformer connection are shown in Figure 5.



- Draw, full size, the given elevations;
- divide the plan into a number of triangles and find their true lengths;
- construct, the complete surface development to show a one-piece pattern of the transformer connection.

Notes:

- The joint line is to be presented along line 7b.
- Ignore sheet metal thickness and allowance for seam.

(20 marks)

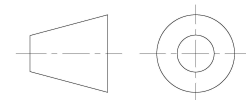
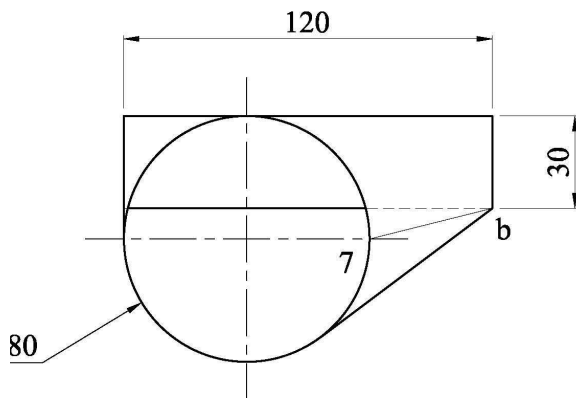
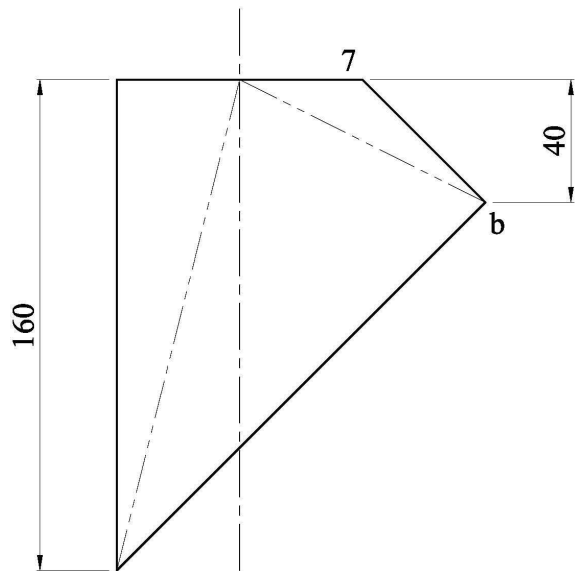

Figure 5

Question 6

An illustration of a solid of revolution pierced by five drilled holes is shown. The elevation and plan in Figure 6 show the machined solid after being turned and drilled respectively.

- Draw full size, the given views and construct the interpenetration curves resulting in the elevation of the holes marked A and B.
- Project an end elevation showing clearly the lines of intersection between the cylindrical holes A and B and the solid.

Do not show hidden detail.

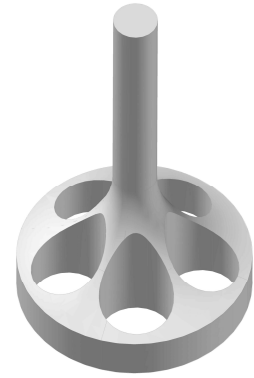

(20 marks)

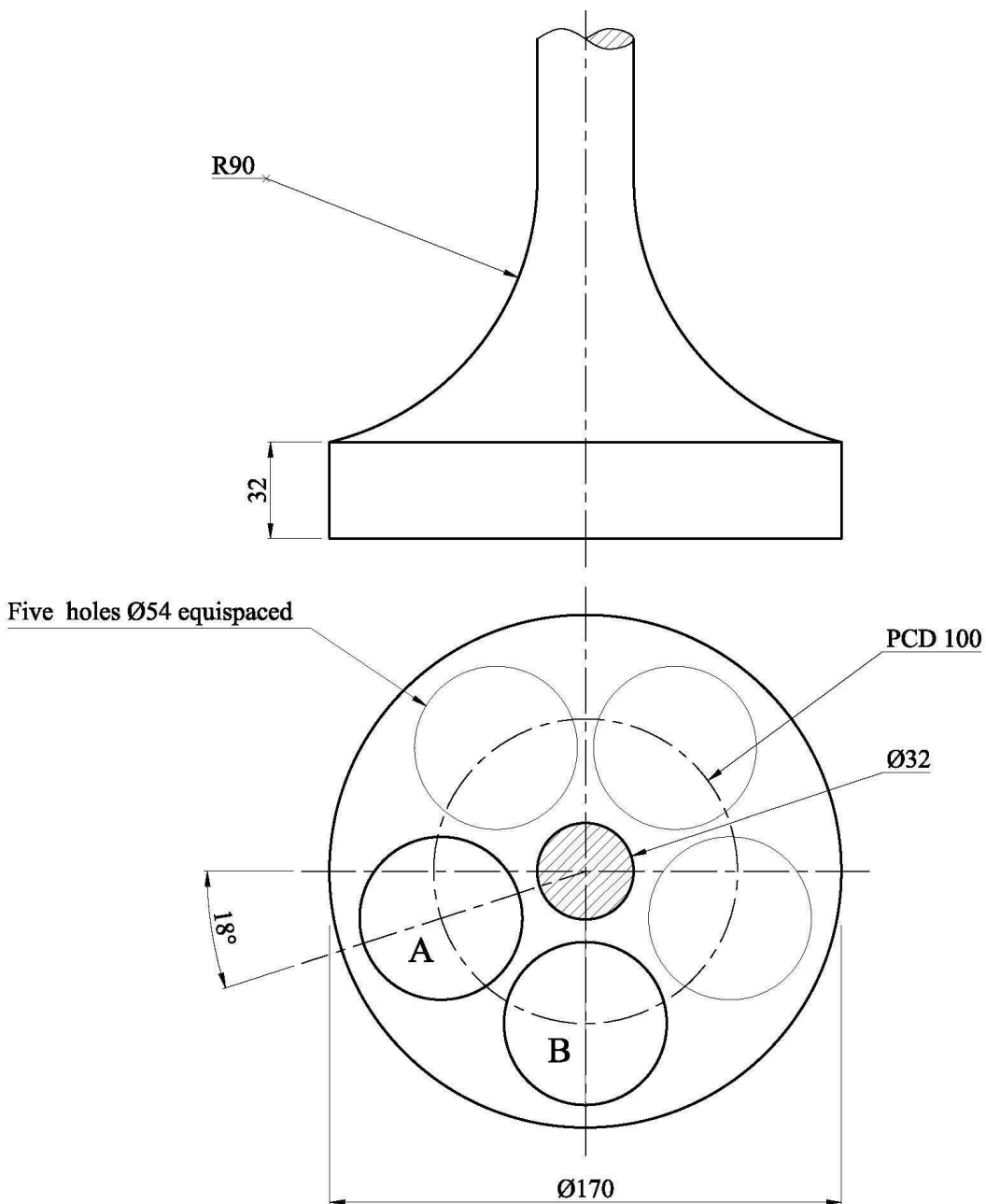

Figure 6

MATRICULATION AND SECONDARY EDUCATION CERTIFICATE EXAMINATIONS BOARD

UNIVERSITY OF MALTA, MSIDA

MATRICULATION CERTIFICATE EXAMINATION
ADVANCED LEVEL
MAY 2013

SUBJECT:	ENGINEERING DRAWING
PAPER NUMBER:	II
DATE:	8th May 2013
TIME:	9.00 a.m. to 12.00 noon.

Directions to Candidates

Write your index number where indicated at the top of all drawing sheets.

Attempt **question 1** and any other **two** questions.

Programmable calculators **cannot** be used.

Unless otherwise stated:

- a. drawings should conform to B.S. or equivalent (ISO) standards;
- b. all dimensions are in millimetres;
- c. all answers are to be accurately drawn with instruments;
- d. all construction lines must be left on each solution;
- e. drawing aids may be used.

Dimensions not given should be estimated.

Careful layout and presentation are important.

Marks will be awarded for accuracy, clarity and appropriateness of constructions.

Mark allocations are shown in brackets.

Question 1 carries 60 marks. Questions 2, 3 and 4 carry 20 marks each.

Question 1

Figures 1a and 1b show illustrations of a BACK CENTRE for a special-purpose inspection machine. The details of the component parts are printed on the two A3 sheets (attached) and are assembled as follows:

The main body, Part item (1), is mounted on the slotted portion of the base, Part item (2). Part item (3), the body adjusting screw is screwed on to the main body and the external retaining ring (circlip) is fitted in the $\varnothing 10 \times 2$ groove of the adjusting screw. The external retaining ring, provides a stop or shoulder for holding the body adjusting screw, retaining the adjusting screw in position. The main body, base and the adjusting screw are secured firmly in position by means of an M16 hexagonal-headed bolt 57 mm long, (not shown).

The M14 threaded portion of the barrel screw, Part item (5), is screwed into the M14 internal threaded hole of the barrel, Part No. 4. Axial movement of the barrel screw is prevented by inserting the barrel locating plates, Part item (7) in the vertical slot of width 5 mm at the right hand end of the barrel screw. The two plates and the barrel screw are retained to the main body by means of four M6 mm countersunk head screws (not shown). When the barrel screw is rotated, the barrel moves axially through the bore of the main body.

The 3 x 5 key incorporated on the keyway plate of Part item (8), is fitted into the 3 x 5 grooved key slot on the underside of the barrel. Two M6 countersunk screws (not shown) secure the keyway plate in position to the left hand end face of the main body. The key on the keyway plate prevents the barrel from rotating while the barrel is moving axially through the bore of the main body.

The centre, Part item (6), is inserted in the tapered bore of the barrel.

The M10 threaded portion and 12 mm diameter shank of the barrel clamping screw, Part item (9), passes through the 12mm diameter hole of the main body. The barrel clamping screw is screwed into the M10 tapped hole of the main body.

Finally, the tommy bar, Part item (10), is screwed to the clamping screw locking the barrel in the desired position.

Draw, full size, in either 1st or 3rd angle projection, the following views of the assembled back centre.

- a) A sectional assembly drawing, the plane of the section and the direction of viewing is indicated by X- X;
- b) a sectional elevation, the plane of the section and the direction of viewing is indicated by Y - Y.

Notes:

- (i) In the presented views the barrel is to be positioned, protruding 40mm from the main body.
- (ii) In the presented views, the tommy bar Part item (10), is to be shown in the vertical position, with the handle in the vertical direction.
- (iii) Show the M16 hexagonal headed bolt in the across corners position.
- (iv) Fillet radii 4mm unless otherwise stated.
- (v) Hidden lines need not be shown unless necessary for clarity.

(60 marks)

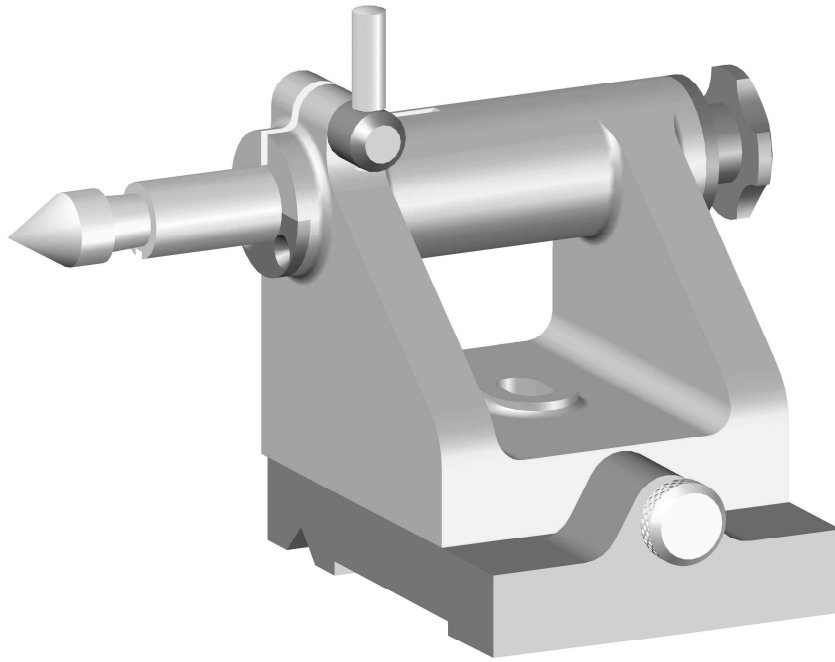
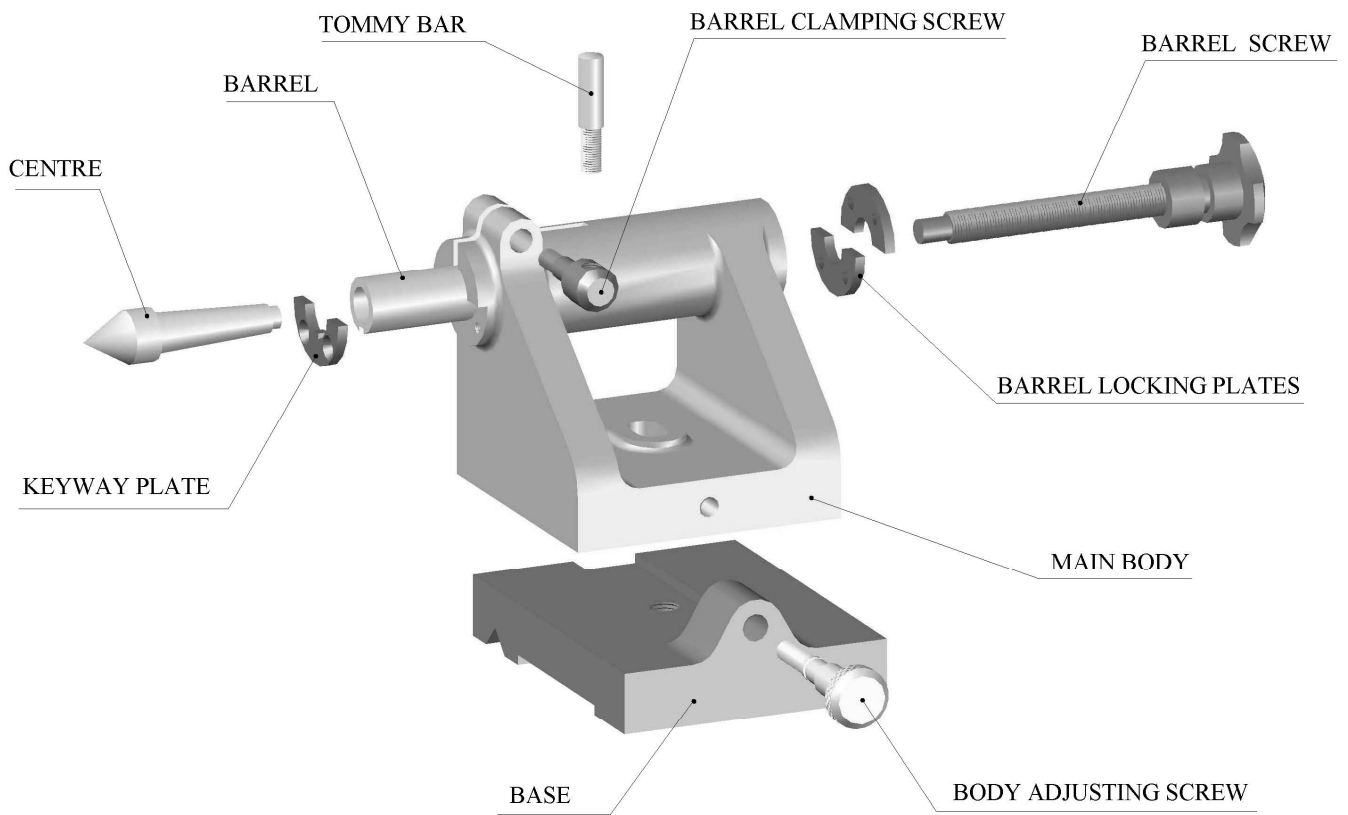

ILLUSTRATION OF THE ASSEMBLED BACK CENTRE
Figure 1a



EXPLODED VIEW OF THE BACK CENTRE
Figure 1b

Question 2

All machined surfaces vary in smoothness depending on the method and tool chosen to produce it. Where it is important that a surface has a particular surface finish, a symbol is used with an arrangement of numbers, symbols and letters.

In general each finishing process has its characteristic surface texture.

- a. Figure 2(a) shows information applied to machining symbols regarding the indication of surface texture on engineering drawing.
Write down what the letters a, b, c, d, and e represent.
- b. Draw two examples of the symbol:
 - i) one example showing that the machining instructions are obligatory and must be done, and
 - ii) one example which indicates that machining on the surface is NOT to be done.
- c. Figure 2 (b) shows symbols for the direction of lay.
Draw a table, copy the symbols shown in Figure 2(b), write neat notes explaining their interpretation and include a sketch to accompany your explanation. You may adopt the method shown in Figure 2 (c) below for your answer.

(20 marks)

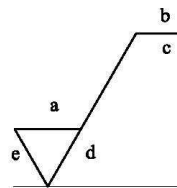

FIGURE 2 (a)

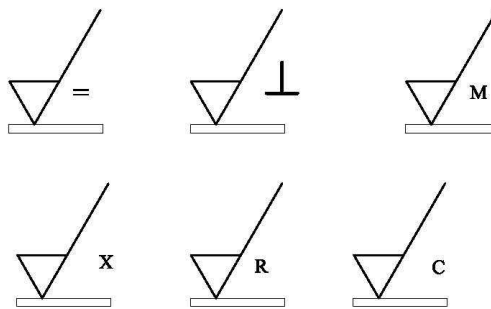

FIGURE 2 (b)

Symbol	Example of use	Interpretation
=		<p>Parallel to the plane of projection of the view in which the symbol is used.</p> <div style="display: flex; align-items: center;"> <div style="margin-right: 10px;">Lay direction</div> </div>

FIGURE 2 (c)

Question 3

An incomplete drawing of a housing, shaft and bearing is shown in Figure 3.

Draw, approximately full-size, a design of the sub-assembly by:

- securing the inner ring of the bearing to the shaft by a locknut;
- including two end covers, locating the shaft in both directions. One end cover is screwed to face P. The other cover is screwed to face Q, and also clamps the outer ring of the bearing to the housing;
- including a feature for lubricating the bearing periodically. The bearing requires regular lubrication to prevent failure under load;
- showing suitable seals installed at the end covers, so as to exclude contaminants, foreign matter and to retain lubrication.

(20 marks)

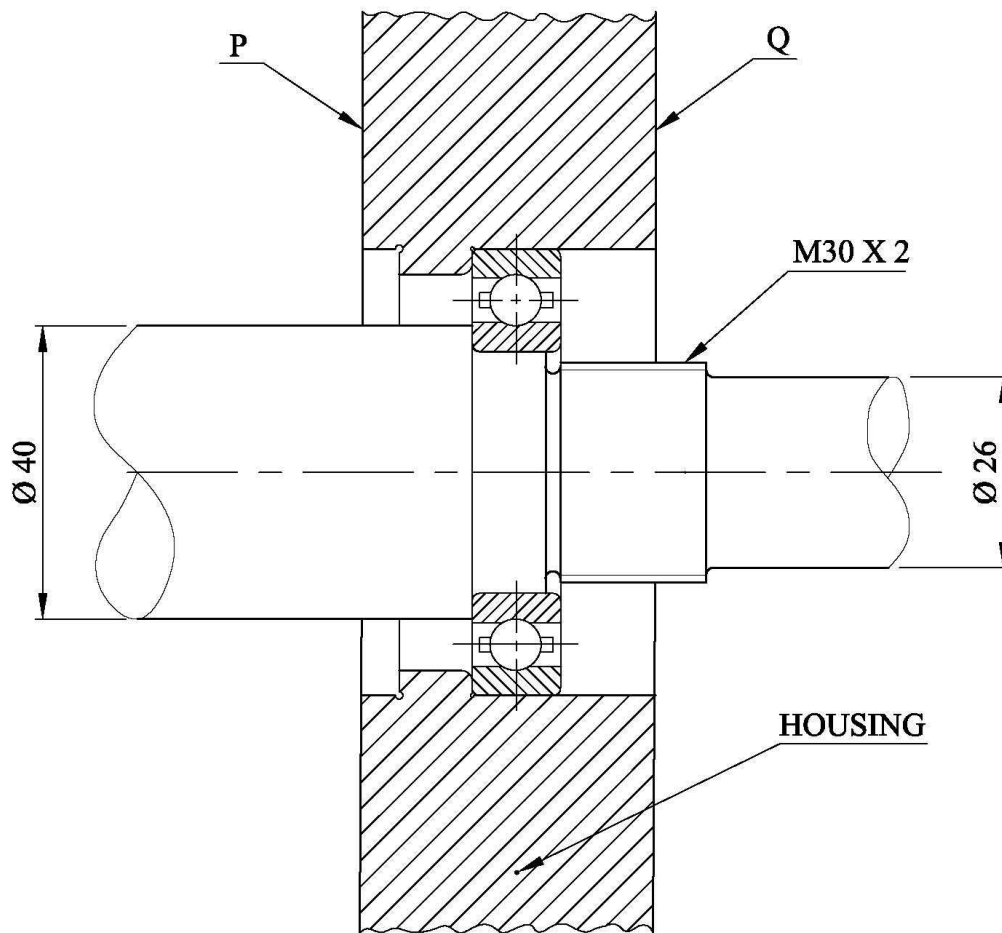

Figure 3

Question 4

A key is a component inserted between the joint of two parts in an axial direction to prevent relative rotation.

- a. Two types of keys are shown in figure 4. Draw, suitable views showing in detail how these keys are fitted and their function.
Write the name and material of each key.
- b. Another type of key is segmental in shape which fits into a corresponding recess.
Draw, suitable views of this type of key. State its advantages and where it is commonly used. Write the name and material of this key.
- c. Draw, a well proportioned drawing of a key which allows axial movement of the wheel on the shaft while still transmitting rotary movement.
State the name and material of this key.

Assume that the diameter of the shaft is 40mm. Proportions are to be included with each drawing of the key.

(20 marks)

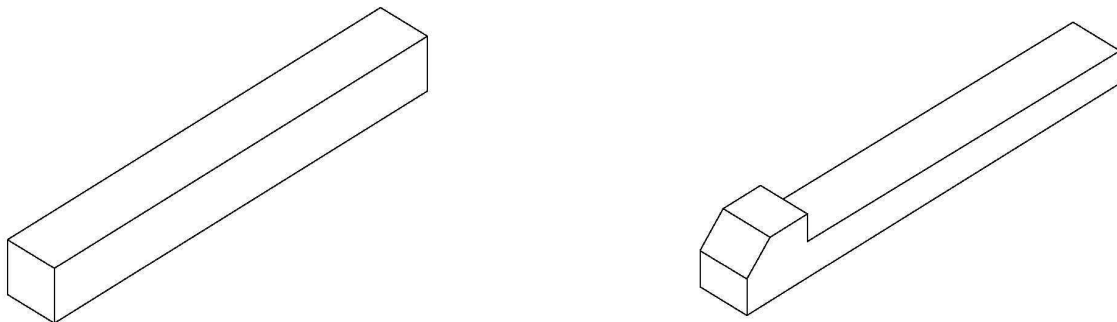
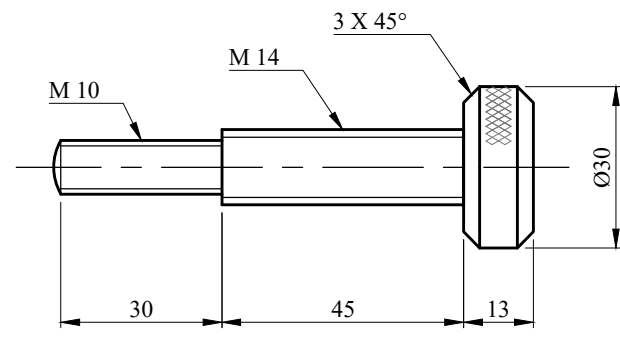
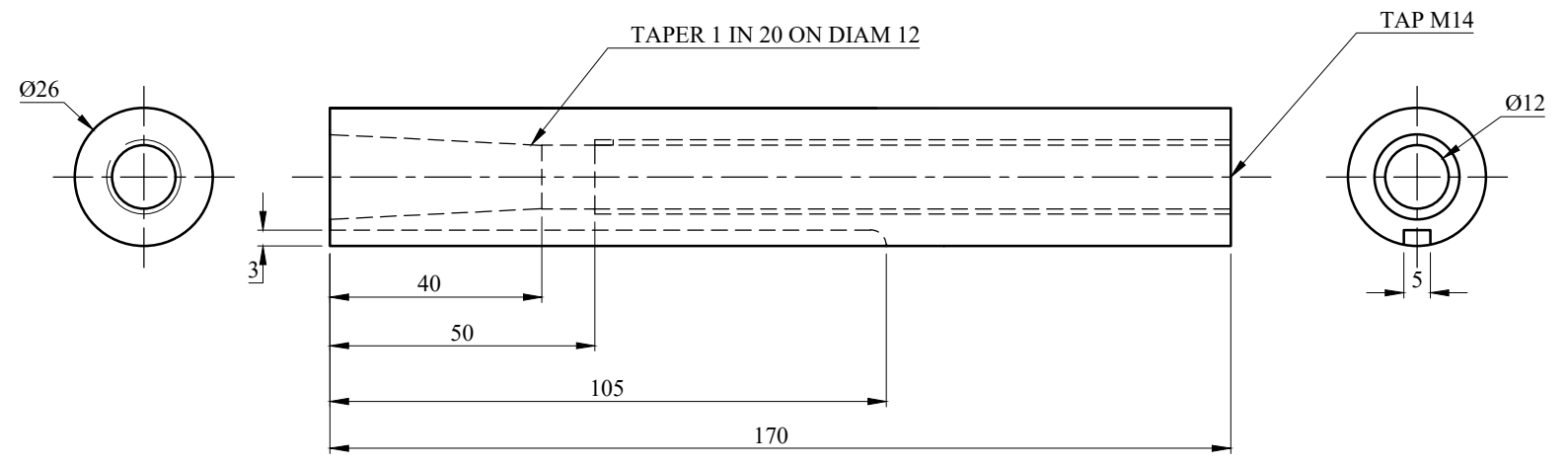

Figure 4



③ BODY ADJUSTING SCREW



④ BARREL

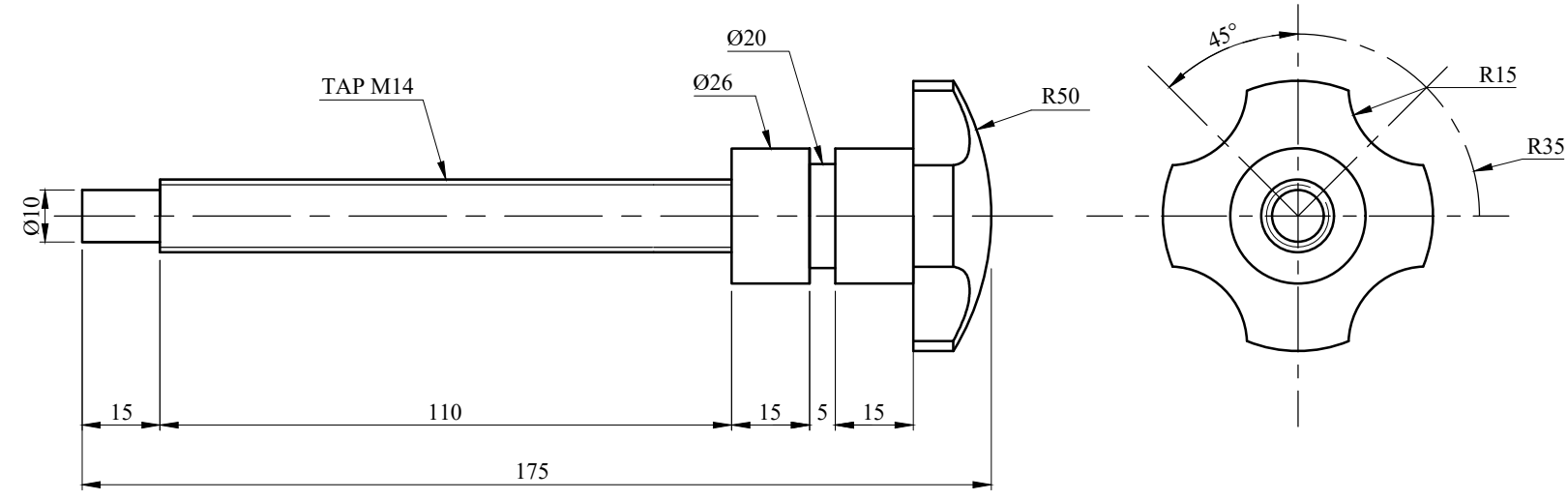

⑤ BARREL SCREW

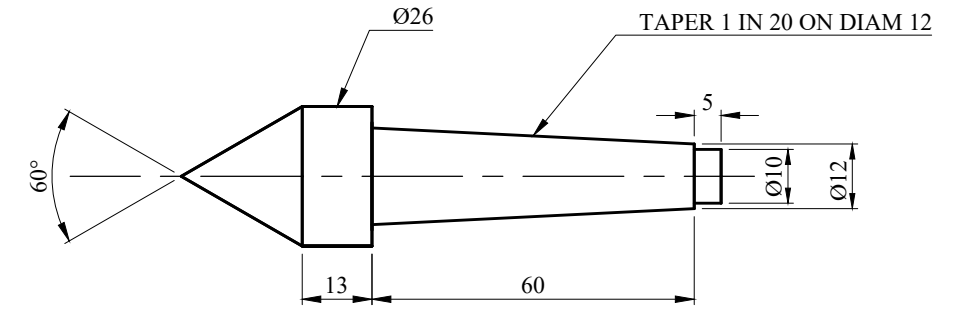

⑥ CENTRE

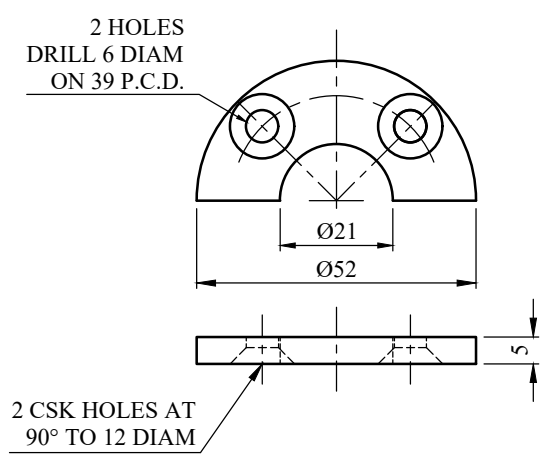

⑦ BARREL LOCATING PLATES
2 OFF

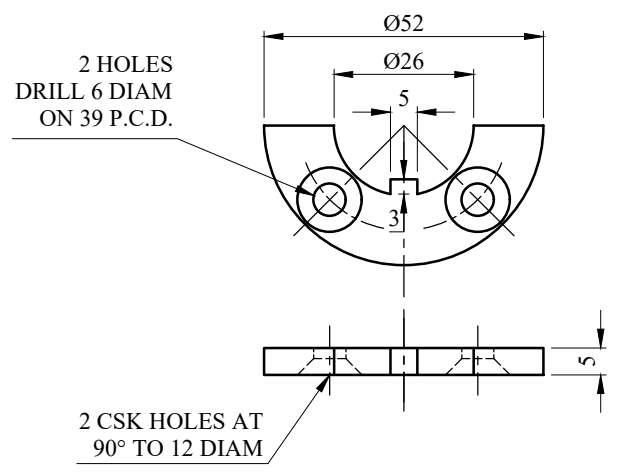

⑧ KEYWAY PLATE

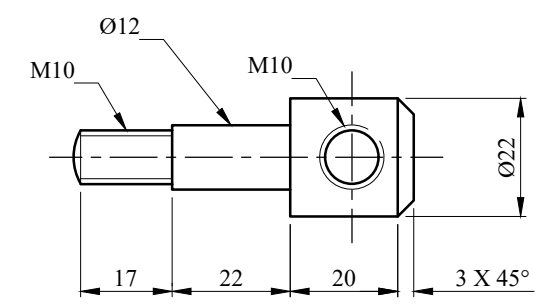

⑨ BARREL CLAMPING SCREW

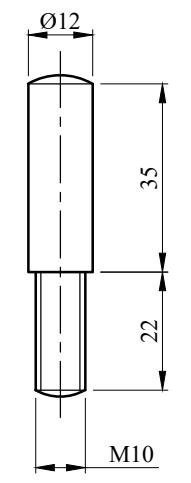

⑩ TOMMY BAR

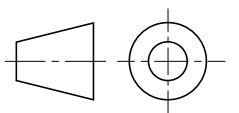

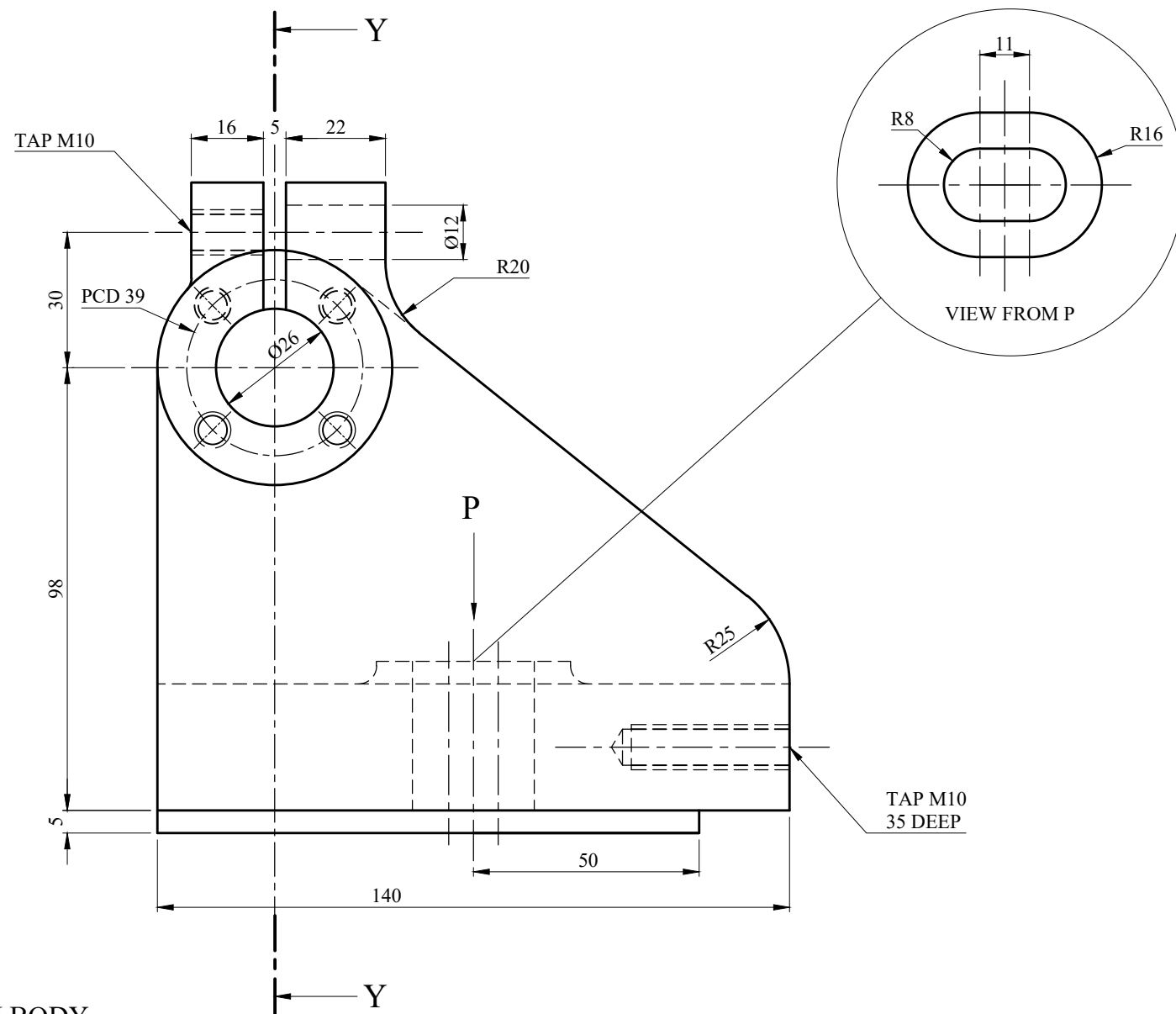
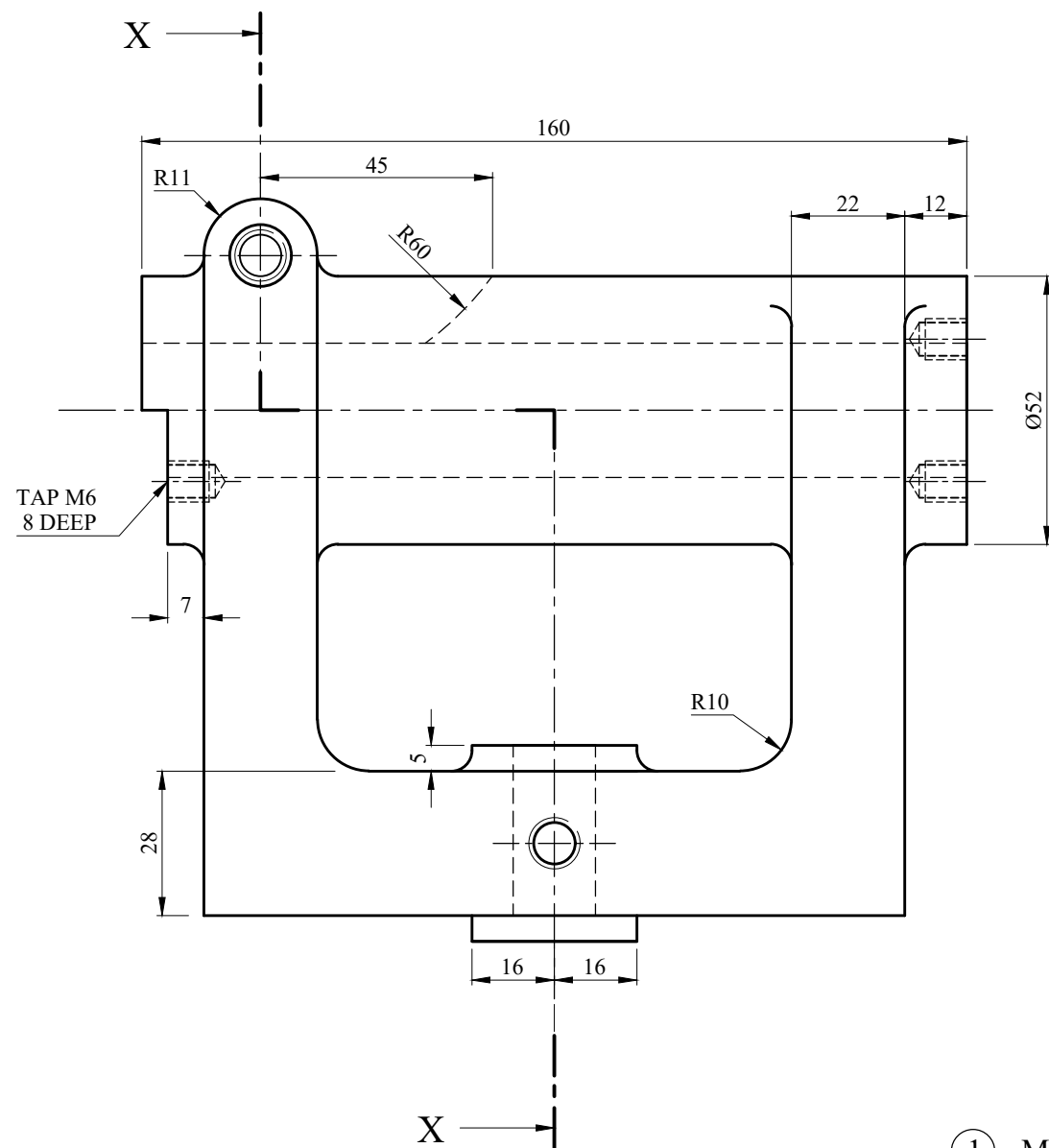

① MAIN BODY

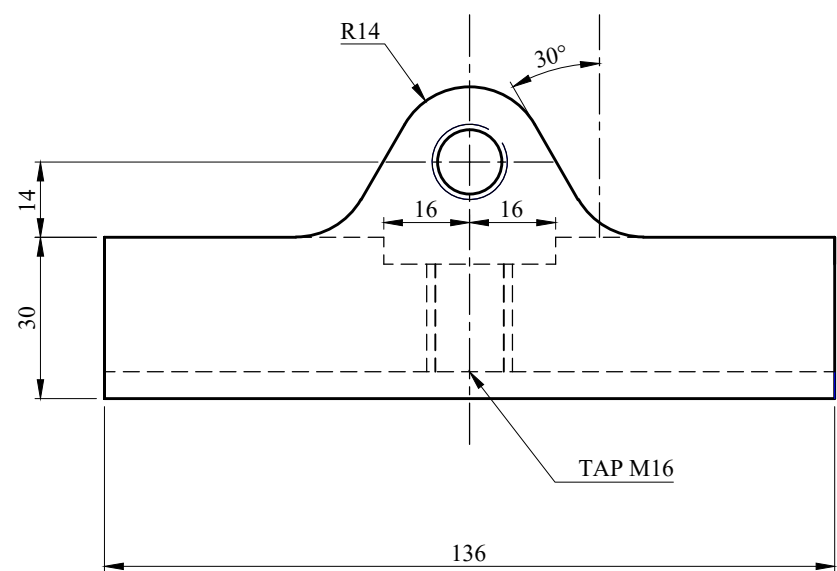

② BASE

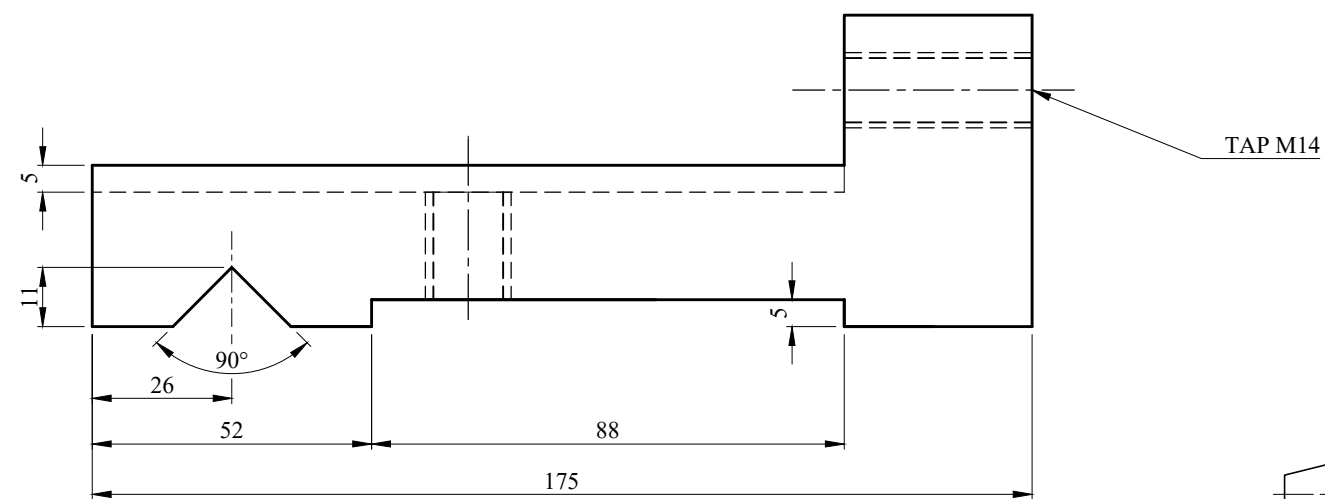

Fillet radii 4mm unless otherwise stated