

MATRICULATION AND SECONDARY EDUCATION CERTIFICATE EXAMINATIONS BOARD  
UNIVERSITY OF MALTA, MSIDA

MATRICULATION EXAMINATION  
ADVANCED LEVEL  
SEPTEMBER 2013

---

<b>SUBJECT:</b>	ENGINEERING DRAWING/GRAPHICAL COMMUNICATION
<b>PAPER NUMBER:</b>	I
<b>DATE:</b>	3rd September 2013
<b>TIME:</b>	9.00 a.m. to 12.00 noon

---

**Directions to Candidates**

Write your index number where indicated at the top of all drawing sheets.

Attempt **any five** questions.

Programmable calculators **cannot** be used.

Unless otherwise stated:

- a. drawings should conform to B.S. or equivalent (ISO) standards;
- b. all dimensions are in millimetres;
- c. all answers are to be accurately drawn with instruments;
- d. unless otherwise stated, all construction lines must be left in each solution;
- e. drawing aids may be used.

Dimensions not given should be estimated.

Careful layout and presentation are important.

Marks will be awarded for accuracy, clarity and appropriateness of constructions.

**Question 1**

A right cone is sectioned as shown in Figure 1. Copy, full size, the given figure and;

- a) construct the two focal spheres to find the position of the focus and the position of the directrix,
- b) draw the directrix, the transverse axis, the focus and the vertex,
- c) construct the ellipse using the eccentricity found,
- d) find the centre of curvature of the point K on the ellipse, situated 35mm from the vertex of the ellipse. Measure and state the length from point K to the centre of curvature.

**(20 marks)**

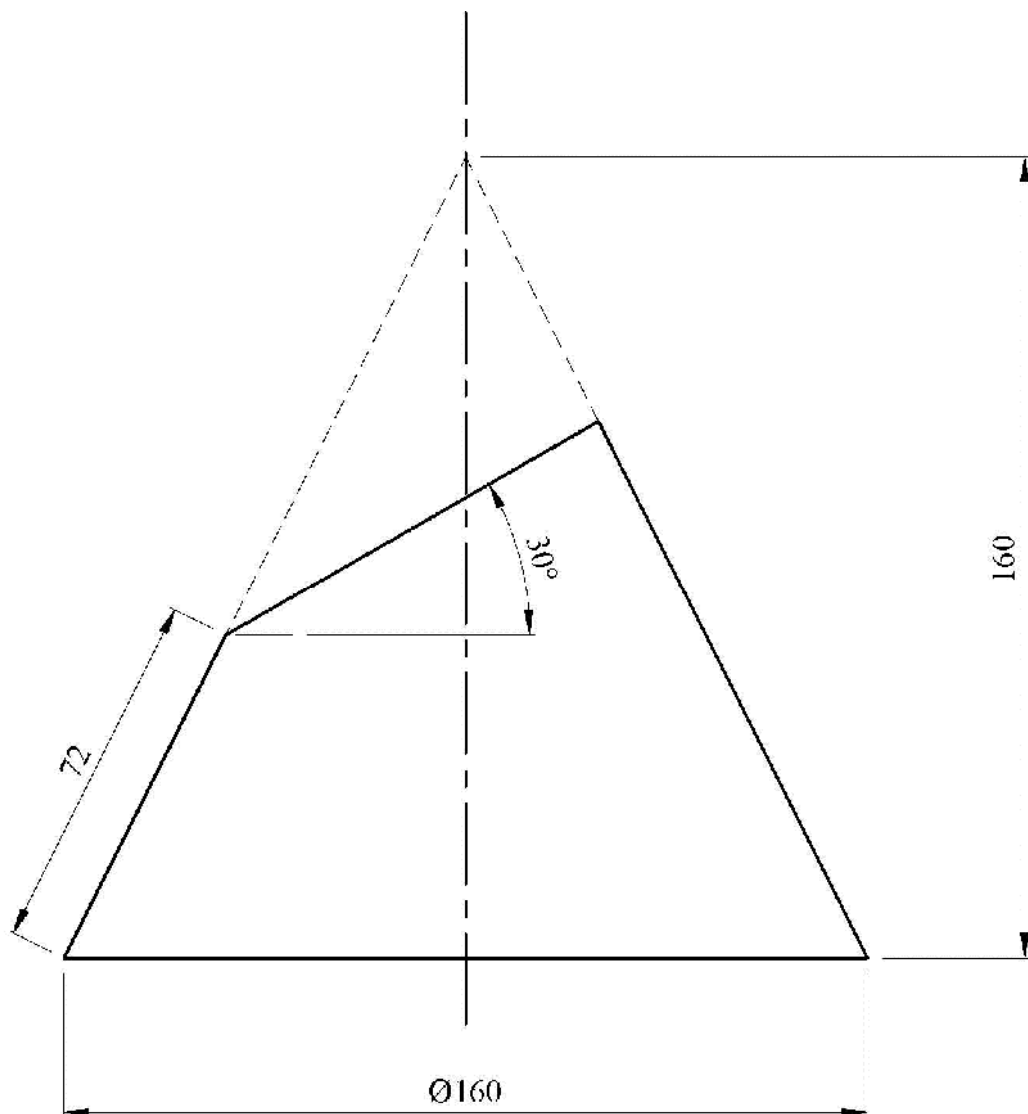

Figure 1

**Question 2**

Two incomplete views of a solid right cylinder cut by an oblique plane as shown in Figure 2b. The traces are positioned as given in the figure. Draw in full size;

- a) the complete plan,
- b) the complete front elevation
- c) a second auxiliary view showing the true shape of the section.

Show all hidden detail.

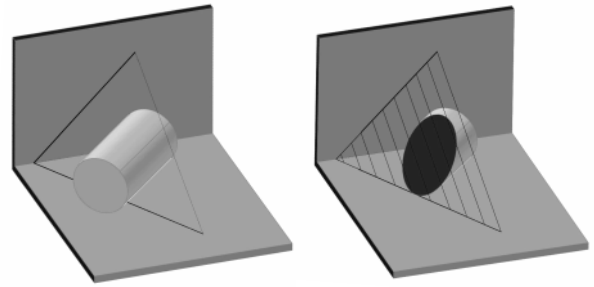
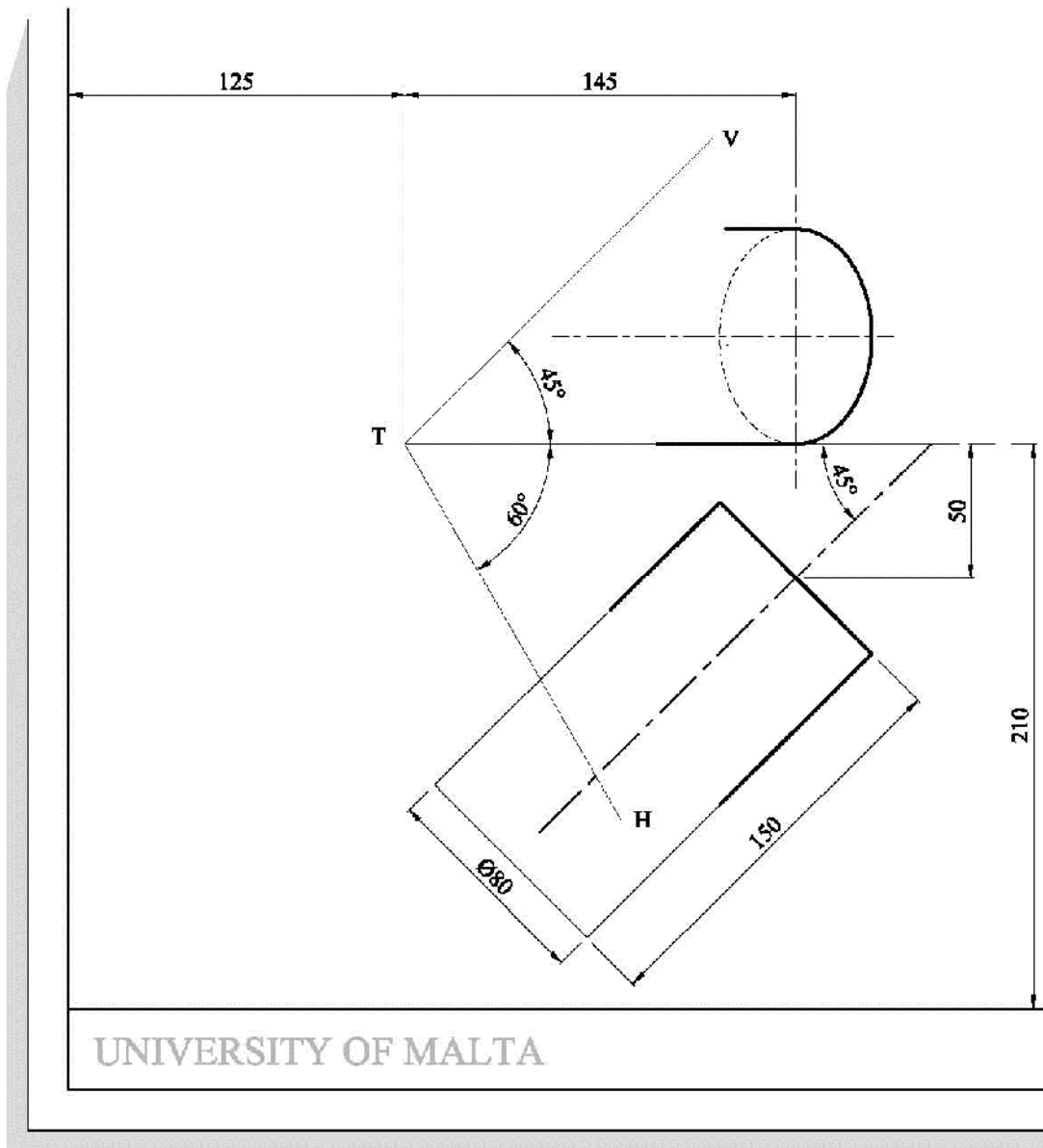

Figure 2a

(20 marks)



UNIVERSITY OF MALTA

Figure 2b

**Question 3**

A square bar is fixed on a lathe and the right end is machined to the shape of a cone (as shown in Figure 3a).

- Copy, full size, the end elevation shown in Figure 3b.
- Copy and complete the front elevation showing the resulting curves.
- Construct an auxiliary elevation as seen when looking in the direction of arrow A.

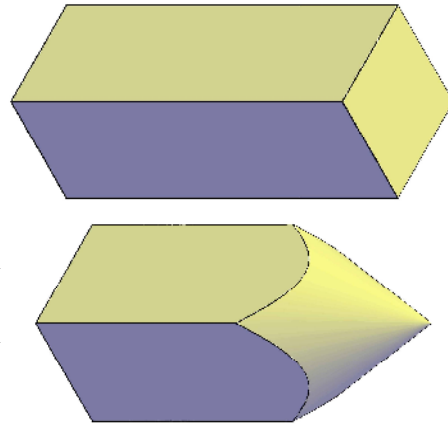

Figure 3a

*Note:*

*Clearly show the construction method applied to generate the curved profiles.*  
**(20 marks)**

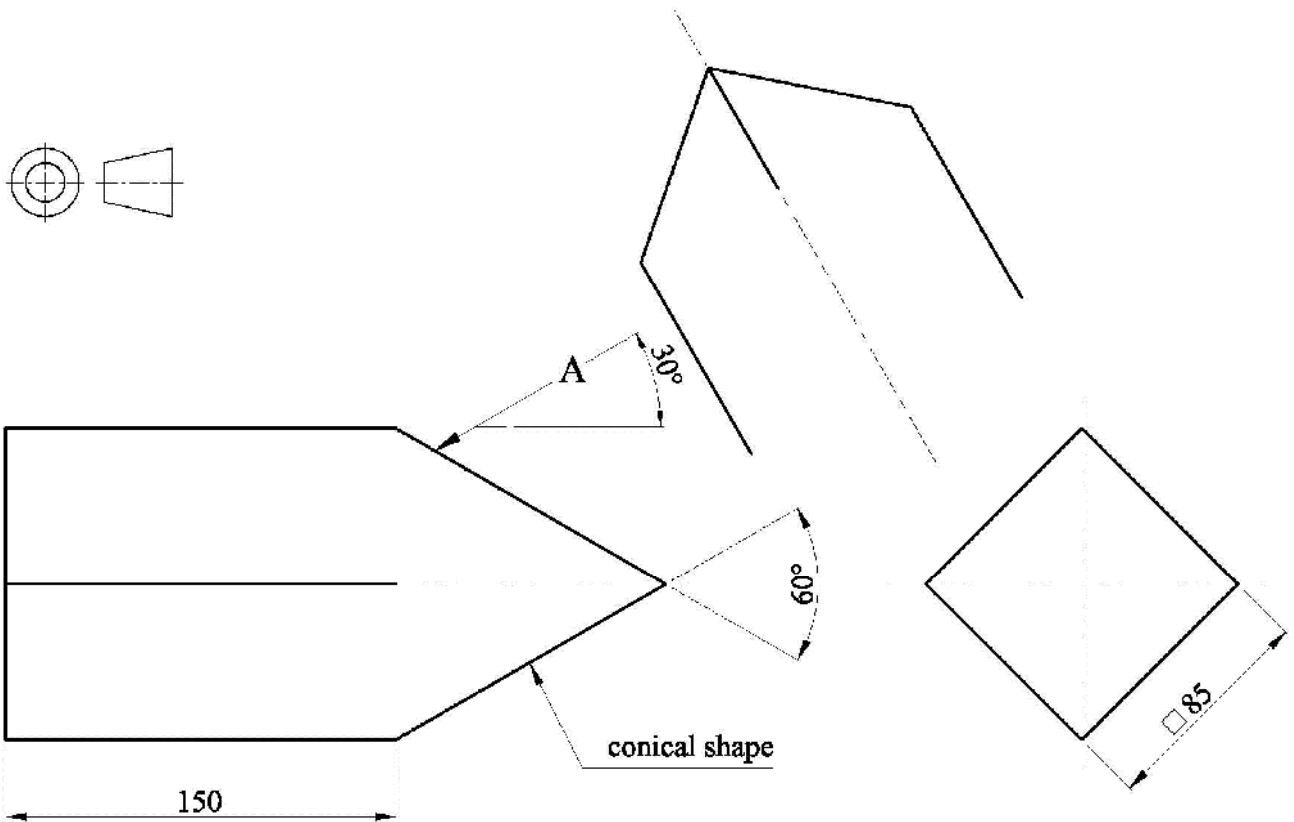

Figure 3b

**Question 4**

An illustration of a glass bowl displayed on a table is given in Figure 4a. Two spheres are resting on the base of the bowl each touching the side of the bowl.

- a. Copy, full size, the two views shown in Figure 4b showing clearly the method applied to locate the points of contact.
- b. A third sphere is to be placed in the bowl resting on the base of the bowl and in mutual contact with the other two spheres and the side of the bowl. The diameter of this sphere is 30 mm.

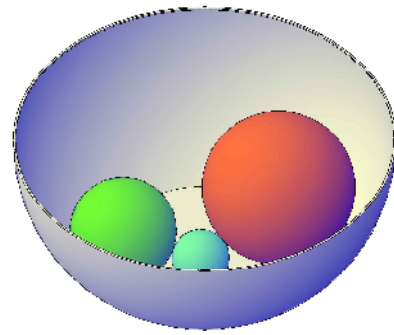

Figure 4a

Notes:

- The third sphere is to be shown visible in the front elevation.
- Show clearly all the necessary constructions.

**(20 marks)**

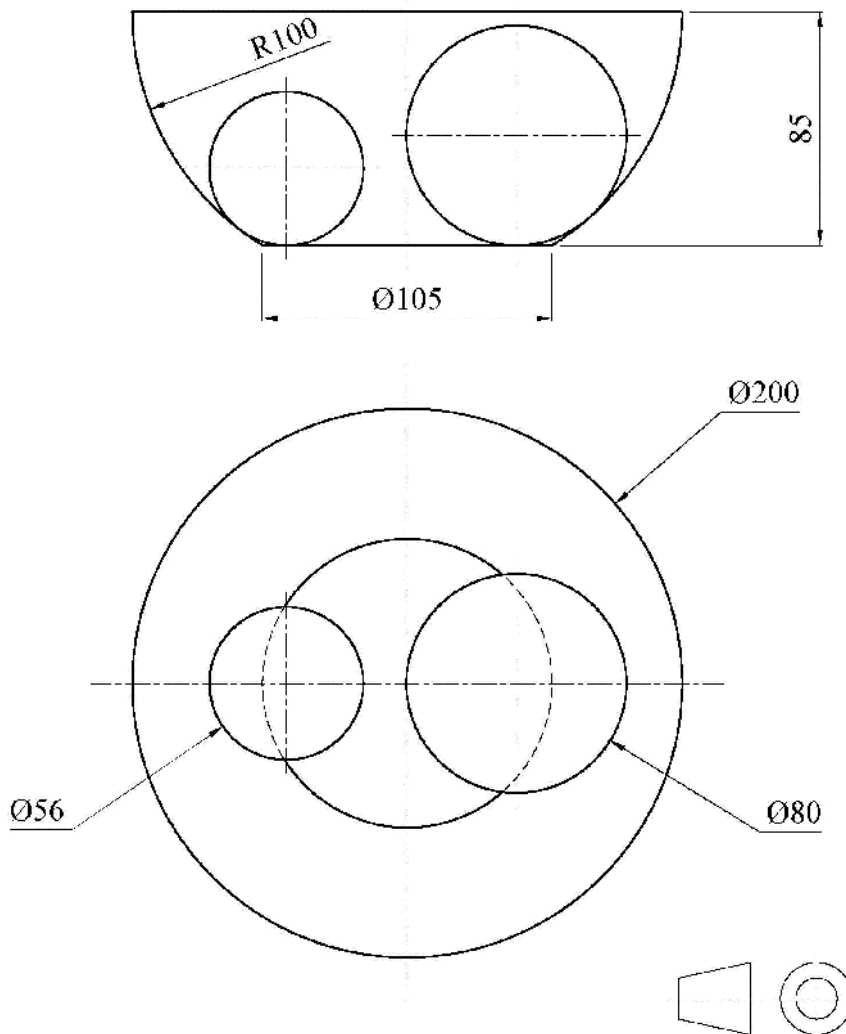

Figure 4b

**Question 5**

A system of vertical forces on an 18.5 metre horizontal beam, has reactions at  $R_L$  and  $R_R$  as shown in Figure 5.

- a. Using a linear scale of 10mm representing 1metre, a force scale of 10mm representing 1kN and a polar distance of 100mm, construct:
  - i. the linear diagram, showing the load distribution along the beam;
  - ii. the shear force and bending moment diagrams;

*It is important that a clear graphical notation system be used to identify the loads acting along the horizontal beam.*
- b. Determine:
  - i. the magnitude and direction of each of the reactions, at  $R_L$  and  $R_R$  ;
  - ii. the position, nature and magnitude of the greatest bending moment;
  - iii. the positions along the beam where the bending moment is zero.

*All necessary calculations must be shown clearly.*

**(20 marks)**

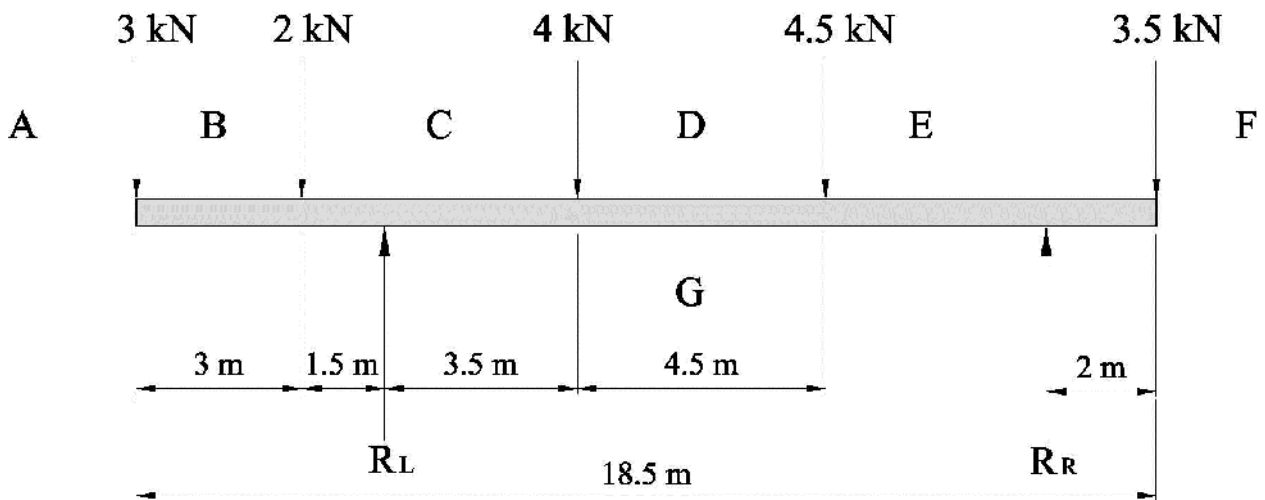

Figure 5

**Question 6**

A sketch of a coved roof and a conical turret is shown in Figure 6a.

An elevation and an incomplete plan of the oblique cone, interpenetrated by the two curves of the roof, are shown in Figure 6b.

- Copy, full size, the front elevation;
- draw and complete the plan;
- draw the end elevation of the oblique cone as seen from the left hand side as indicated by the arrow;
- construct a half surface development of the upper part of the oblique cone;

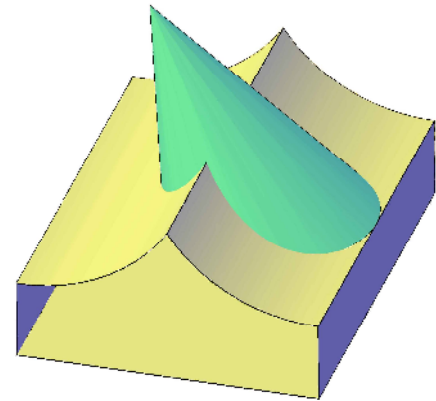

Figure 6a

*Notes:*

*In your half development, present the seam line along the line X-X.  
Ignore material thickness and additional allowance for the seam joint.*

**(20 marks)**

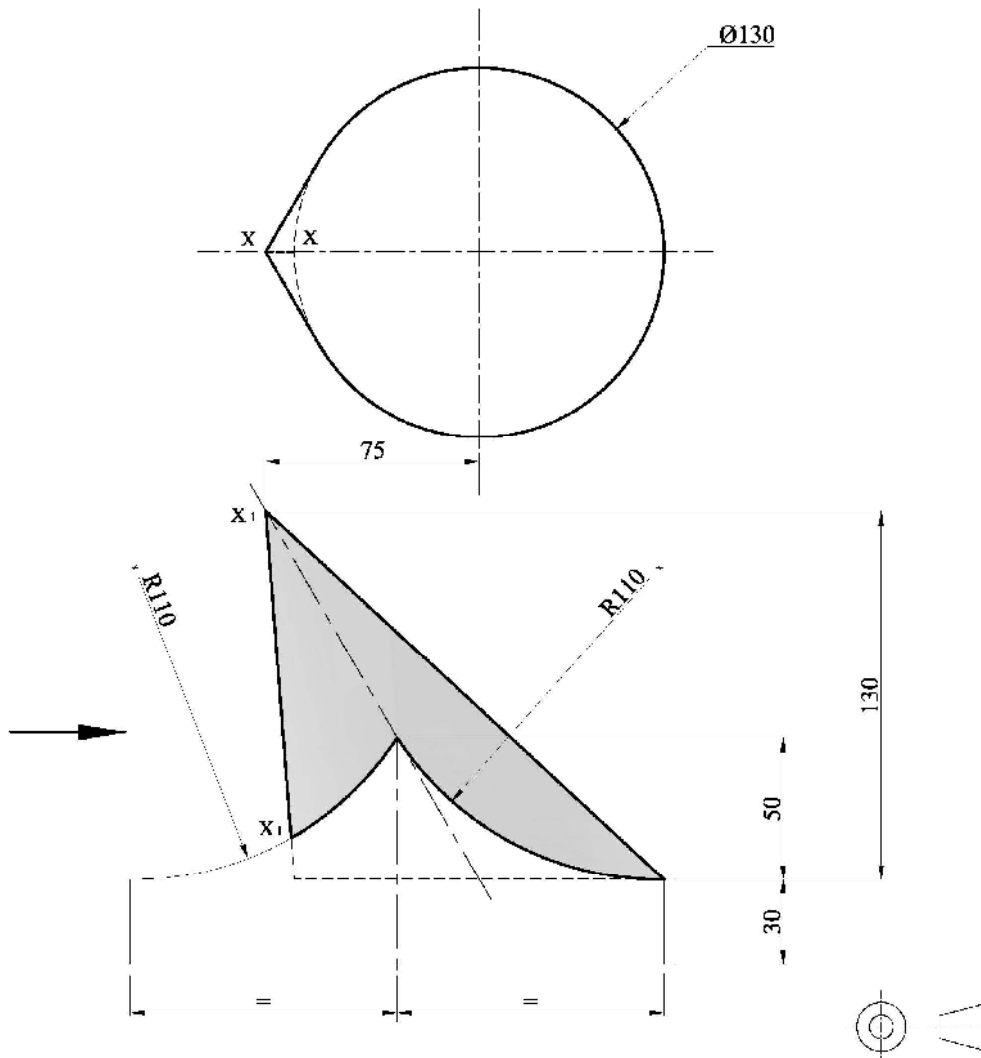

Figure 6b

MATRICULATION AND SECONDARY EDUCATION CERTIFICATE EXAMINATIONS BOARD  
UNIVERSITY OF MALTA, MSIDA  
MATRICULATION EXAMINATION  
ADVANCED LEVEL  
SEPTEMBER 2013

---

<b>SUBJECT:</b>	GRAPHICAL COMMUNICATION
<b>PAPER NUMBER:</b>	II
<b>DATE:</b>	4th September 2013
<b>TIME:</b>	9.00 a.m. to 12.00 noon

---

**Directions to Candidates**

Write your index number where indicated at the top of all drawing sheets.

Attempt **question 1** and any other **three** questions.

Programmable calculators **cannot** be used.

Unless otherwise stated:

- a. drawings should conform to B.S. or equivalent (ISO) standards;
- b. all dimensions are in millimetres;
- c. all answers are to be accurately drawn with instruments;
- d. all construction lines must be left on each solution;
- e. drawing aids may be used.

Dimensions not given should be estimated.

Careful layout and presentation are important.

Marks will be awarded for accuracy, clarity and appropriateness of constructions.

Colour/shading should be used where appropriate.

Mark allocations are shown in brackets.

Question 1 carries 34 marks. Questions 2, 3, 4 and 5 carry 22 marks each.



**Question 1** (This question is compulsory)

The front view and the half sectional plan (X-X) of a **Pergola** is shown in Figure 1. A pergola is a garden feature that provides a shady sitting/dining area. This particular structure has a raised tiled platform which can be accessed by means of a wide step at the front. The four pillars, situated at the corners of the platform, support the cross-beams and the rafters. The garden furniture consists of one wooden table and four wooden stools. The curtains at the front and at the back add an elegant touch while providing a shield from the sun when drawn.

The given views constitute an integral part of the design process, but fail to convey a feeling of the **3D** proportions of this garden structure.

You are to meet this requirement by drawing a **single-point estimated perspective drawing**. The viewing direction required is indicated by the arrows at the bottom of the figure.

- i) Using **three** preliminary sketches, in rectangles 42mm x 28mm, explore alternative positions of the horizon line and identify the one which, in your opinion, best describes the spaciousness of the pergola.  
(3 marks)
- ii) Based on your choice made in (i), produce the required illustration on a single side of an A2 size paper making the best use of the space available (the suggested floor tile size is 35mm).  
(25 marks)
- iii) Enhance your answer graphically using colours, tone and texture.  
(6 marks)

*You are not expected to apply colour/tone/texture to your whole illustration. You are advised to limit their use to a small area on each **different** item appearing in your illustration.*

**(34 marks total)**

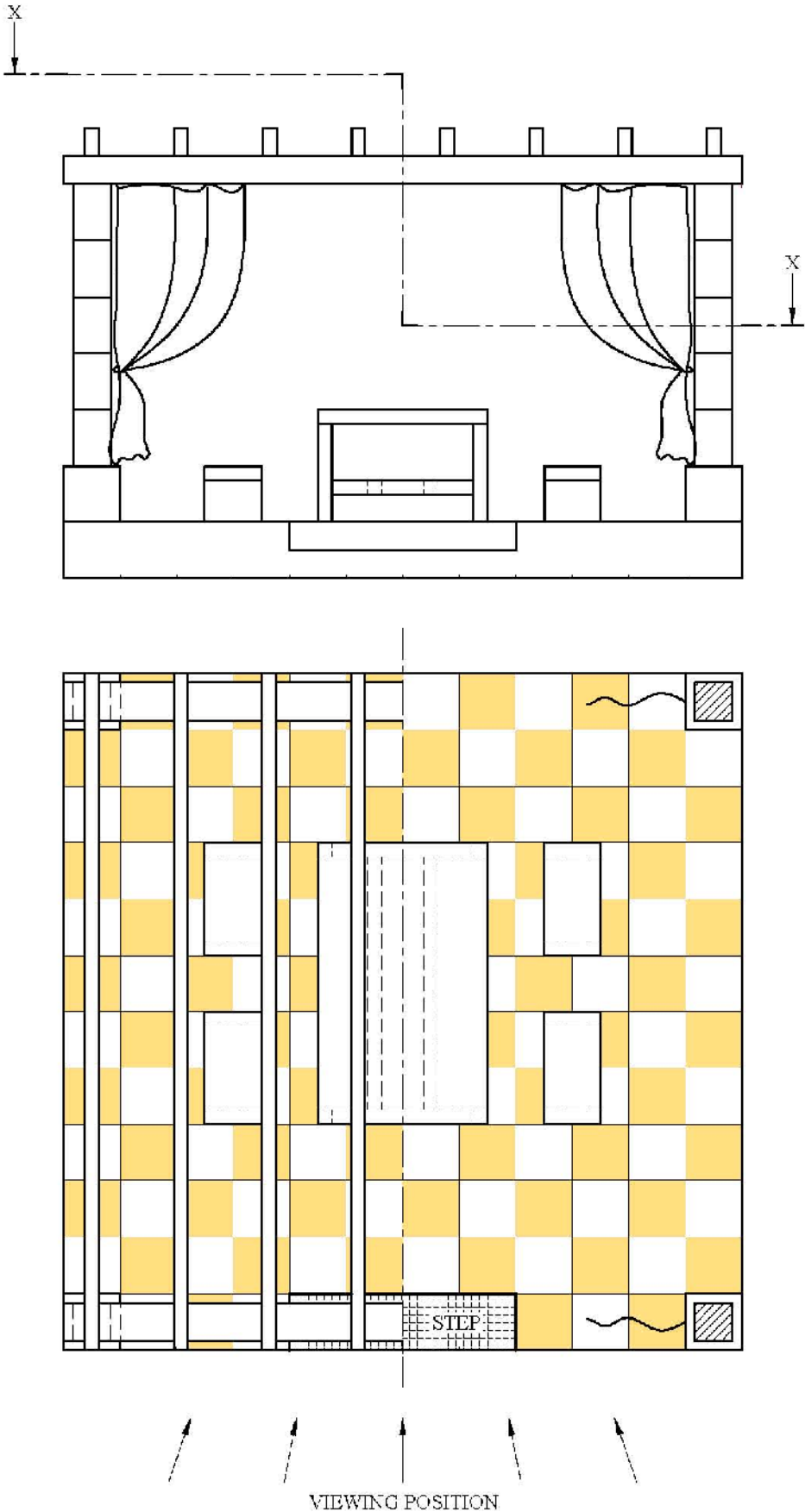

Figure 1

## Question 2

A company, specialising in educational wooden toys, is introducing a new range of *Do It Yourself* assembly kits. To facilitate the assembly, the company is preparing a set of visual instructions. The exploded view of a wooden toy train (given below) has already been produced. You have been asked to:

- i) produce a well proportioned freehand pictorial drawing of the assembled toy train;  
(10 marks)
  - ii) render your drawings using suitable colours;  
(4 marks)
  - iii) draw a close-up visual instruction to illustrate how to press in the chimney, by using thumb pressure, in order to hold the engine compartment and the chassis together.  
(8 marks)
- (22 marks total)**

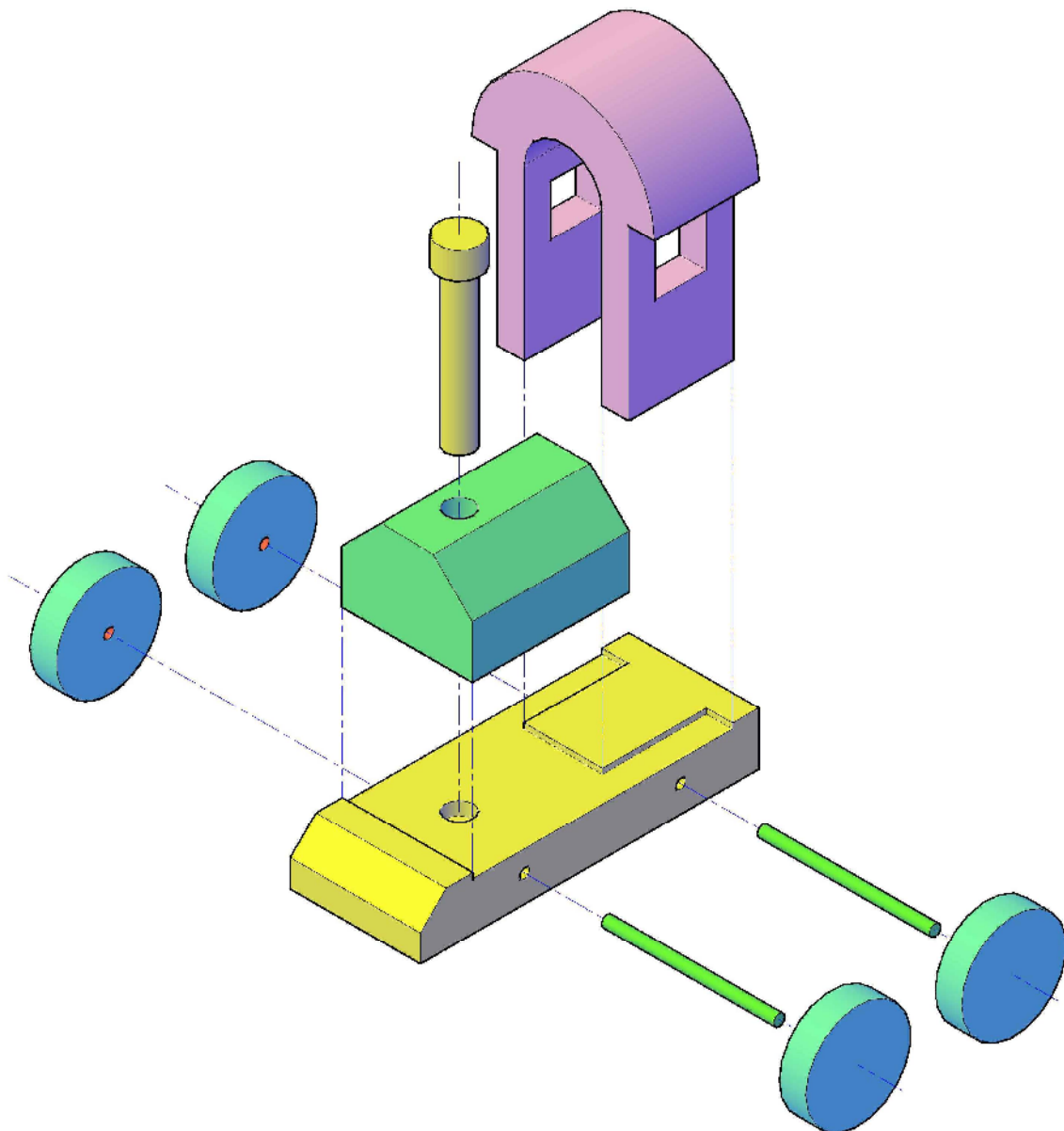

Figure 2

### Question 3

A survey to investigate the impact of **social networking** on our daily lives, was carried out amongst adults aged 18+. The following are some interesting findings:

- a) 30% of the adults interviewed spend no time on social networking, 20% spend 10 minutes daily, 15% spend 30 minutes daily, 15% spend 1 hour daily, 10% spend 1.5 hours daily and the remaining 10% spend 3 hours daily.
- b) Social networking is replacing real-life socialising, sleep, household tasks, cooking, exercise, time for children and reading books.
- c) The following are the percentages per age groups that use social networking sites:
  - ❖ 85% of 18 - 25 year olds
  - ❖ 75% of 25 - 34 year olds
  - ❖ 50% of 35 - 44 year olds
  - ❖ 40% of 45 - 54 year olds
  - ❖ 18% of 55 - 64 year olds
  - ❖ 30% of 65+

Your task is to create a visual representation reflecting the findings of the social networking survey results. Represent the findings (a) by means of a 3D chart, the findings (b) by means of graphic symbols and the findings (c) by means of a 2D graph.

- i) Draw preparatory sketches on the left hand side of your sheet to show your developing ideas regarding the social networking theme and the general layout of the infographic chart. Please note that infographics normally rely more heavily on graphic symbols and graphs than words to convey the message.

(6 marks)

- ii) When you are satisfied with the preparatory sketches, proceed with the final realisation as shown in the figure below.

(16 marks)

**(22 marks total)**

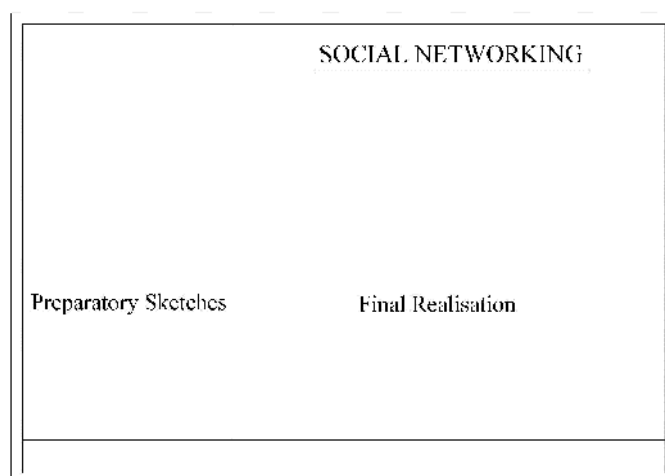

Figure 3

### Question 4

**Polar Ice** is a growing company that distributes ice by means of refrigerated trucks (Figure 4a). The company has a polar bear as its **mascot** (Figure 4b), and boasts a fast 24/7 service. As part of the brand awareness campaign, the company decided to launch a competition for the design of the side panels of their trucks. The design brief of the competition specified the following requirements:

- The name of the company **POLAR ICE** and its **mascot** are to be integral elements of the design.
- The fonts (2-D or 3-D) are to be designed to denote the fast delivery of the ice blocks.
- The pencil work and the colours used to draw the fonts are to denote the texture of ice.
- The background details and colours should denote a freezing environment.
- The tag line **FAST 24/7 SERVICE** is to be included.

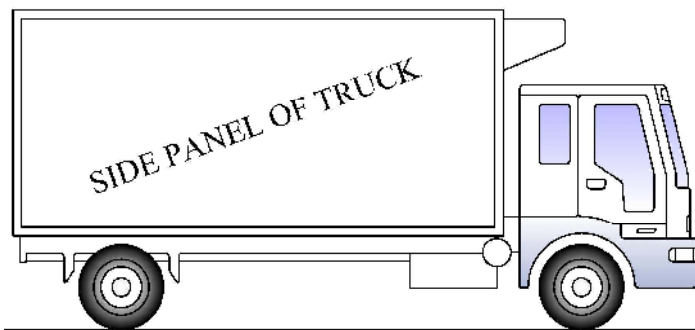

Figure 4a



Figure 4b

In response to the above brief, you are to submit your design. Your work is to be broken down in the steps given below, with each part clearly identified.

**i) Written analysis**

Identify, using keywords/short phrases, the main parameters of the brief. (2 marks)

**ii) Graphical analysis**

Based on your response to i), produce a series of sketches that illustrate your developing ideas. (6 marks)

**iii) Graphical synthesis**

Clearly identify those elements produced in your response to ii) that you intend to use in your final image. (2 marks)

**iv) Final realisation**

Produce your final solution in a rectangle 300mm X 140mm. (12 marks)

*Render your drawing using suitable colours.*

**(22 marks total)**

**Question 5**

Figure 5a shows the surface development of a standard French Fries packaging net, also known as development. The cut lines are denoted by a continuous line, the fold lines are indicated by broken lines and the glue flaps are shown cross-hatched.

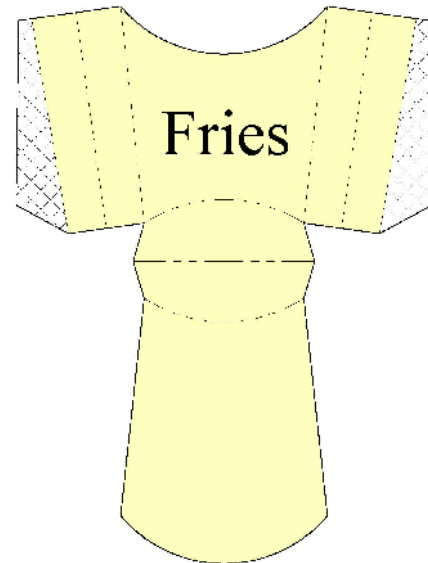

Figure 5a

- a) Make a well proportioned 3-D freehand drawing of the folded and glued package. Render your drawing.

(10 marks)

- b) Design a typogram using the word FRIES to give the packaging an individual graphic identity.

*Note:*

*A typogram is a logo made up of letters whose forms are manipulated to express the meaning of the represented word as per examples shown in Figure 5b*



Figure 5b

Your work must be broken down in the steps given below, with each part being clearly identified.

**i) Written analysis**

Write down keywords/short phrases associated with the word **Fries** and how you intend to alter the letter/s in order to express the meaning of the word.

(2 marks)

**ii) Graphical analysis**

Based on your response to (i), produce a series of sketches that graphically illustrate your developing ideas.

(3marks)

**iii) Graphical synthesis**

Clearly identify those elements produced in your response to (ii) that you intend to use in your final design.

(1mark)

**iv) Final realization**

Produce your final solution in a square side 150mm. Render the drawing using suitable colours.

(6 marks)

**(22 marks total)**

*End of examination paper*