



SUBJECT:	Engineering Drawing/Graphical Communication
PAPER NUMBER:	I
DATE:	31 st May 2022
TIME:	9:00 a.m. to 12:05 p.m.

Directions to Candidates

Write your index number where indicated at the top of all drawing sheets.

Attempt any **FIVE** questions.

Programmable calculators **cannot** be used.

Unless otherwise stated:

- drawings should conform to B.S. or equivalent (ISO) standards;
- all dimensions are in millimetres;
- all answers are to be accurately drawn with instruments;
- all construction lines must be left in each solution;
- drawing aids may be used.

Dimensions not given should be estimated.

Careful layout and presentation are important.

Marks will be awarded for accuracy, clarity and appropriateness of constructions.

Question 1.

An illustration of a right cone cut by an oblique plane is given in Figure 1a.

Two orthographic views and the traces of the oblique plane (VT, HT) cutting the cone are given in Figure 1b.

You are requested to:

- a) copy the given views; (1)
- b) project an auxiliary view of the cone, showing the oblique plane as an inclined cutting plane; (3)
- c) project the truncated plan with the upper part of the cone removed; (3)
- d) project the truncated front elevation; (3)
- e) project the true shape of cut; (3)
- f) locate, by construction, the focal sphere in the first auxiliary projection; (2)
- g) determine the positions of the focus, vertex and directrix of the conic section; (3)
- h) state its ratio of eccentricity and its technical name. (2)

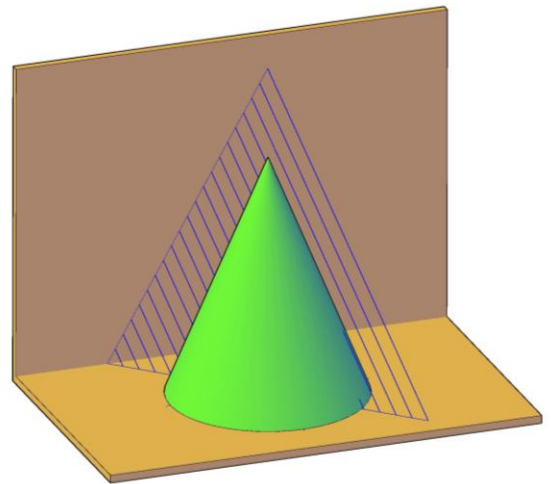

Figure 1a

(Total: 20 marks)

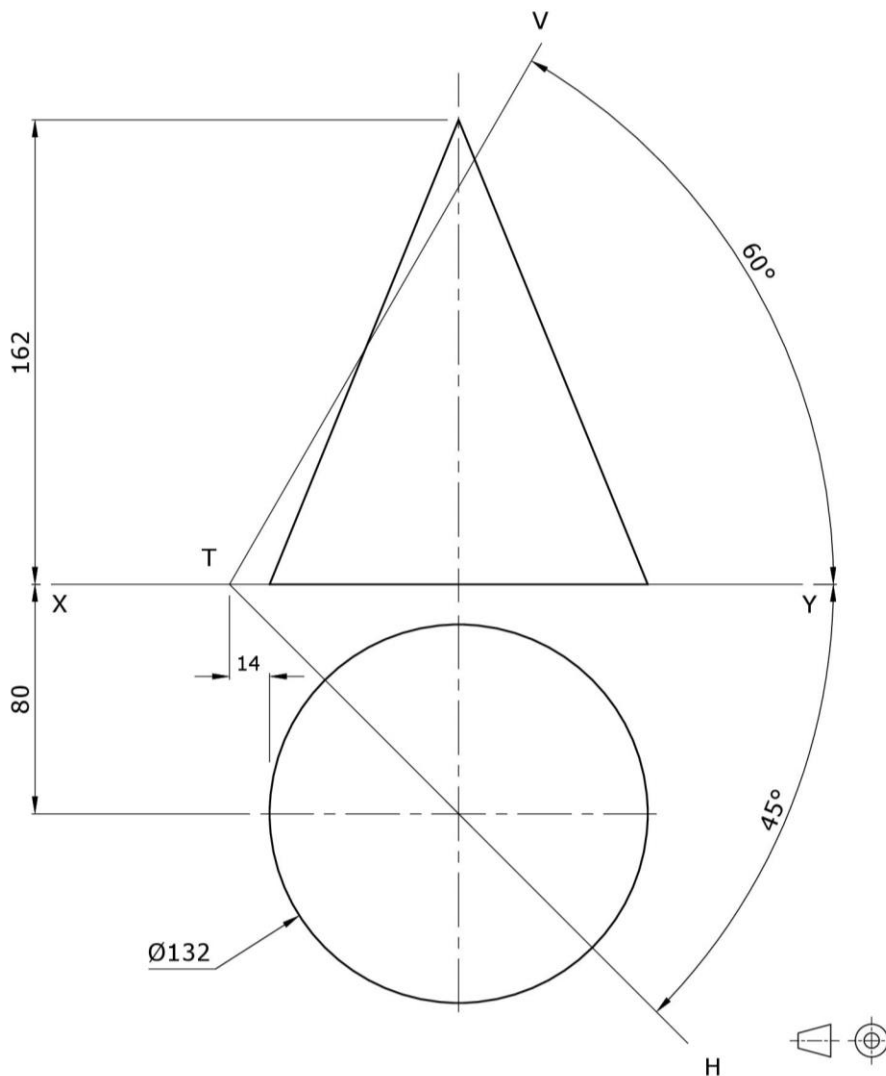

Figure 1b

Question 2.

Three orthographic views of a machined component are given in Figure 2.

You are requested to:

- a) copy the given views (do not show hidden details); (6)
- b) draw a small preparatory freehand isometric sketch of the component, placing corner X of the isometric crate in the lowermost position; (2)
- c) draw a full-size isometric view of the machined component. (12)

(Total: 20 marks)

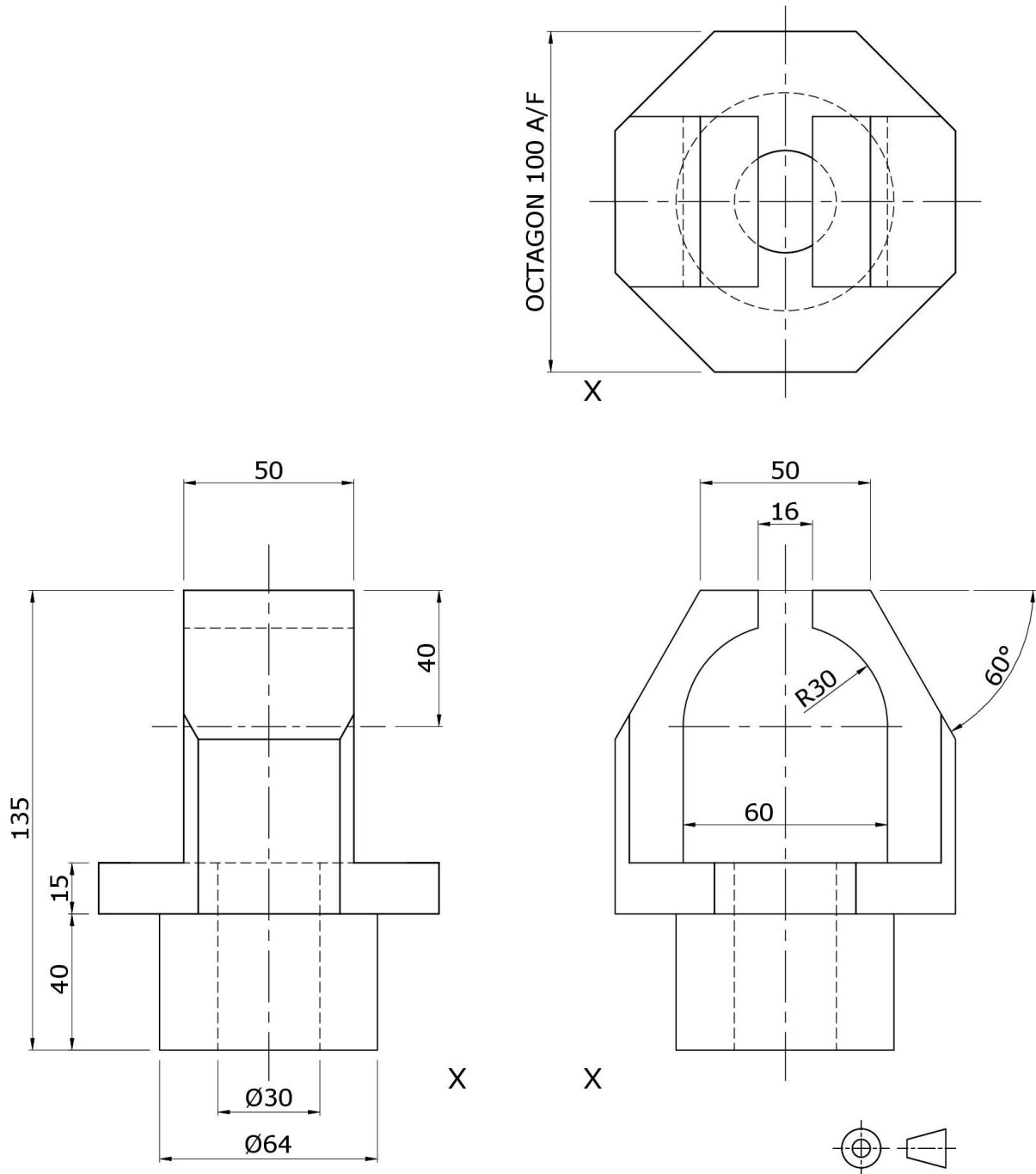

Figure 2

Question 3.

In the mechanism shown in Figure 3, O_1 , O_2 and O_3 are fixed points.

- $O_1 A$ is a crank which rotates in an anticlockwise direction about centre O_1 .
- $O_2 B$ is a link pivoted at O_2 .
- $O_3 D$ is a link pivoted at O_3 .
- BAC is a link pivoted at A and pin jointed at B and C.
- A is the mid-point of link BAC.
- Link CD is pin jointed to links BAC and $O_3 D$ at C and D.
- Point P is the mid-point of link CD.
- PQ is a link pivoted at P.
- End Q of link PQ slides along horizontal rail RS.

You are requested to:

- | | |
|---|-----|
| a) copy Figure 3; | (2) |
| b) plot the locus traced out by pin joint C for one revolution of crank $O_1 A$; | (5) |
| c) plot also the locus of point P; | (5) |
| d) determine the positions of slider Q along rail RS; | (3) |
| e) measure and state the length of stroke of slider Q; | (1) |
| f) draw the displacement diagram of slider Q. | (4) |

Notes:

$O_1 A = 25$ mm, $O_2 B = 105$ mm, $BC = 130$ mm, $CD = 135$ mm, $O_3 D = 150$ mm, $PQ = 160$ mm.

(Total: 20 marks)

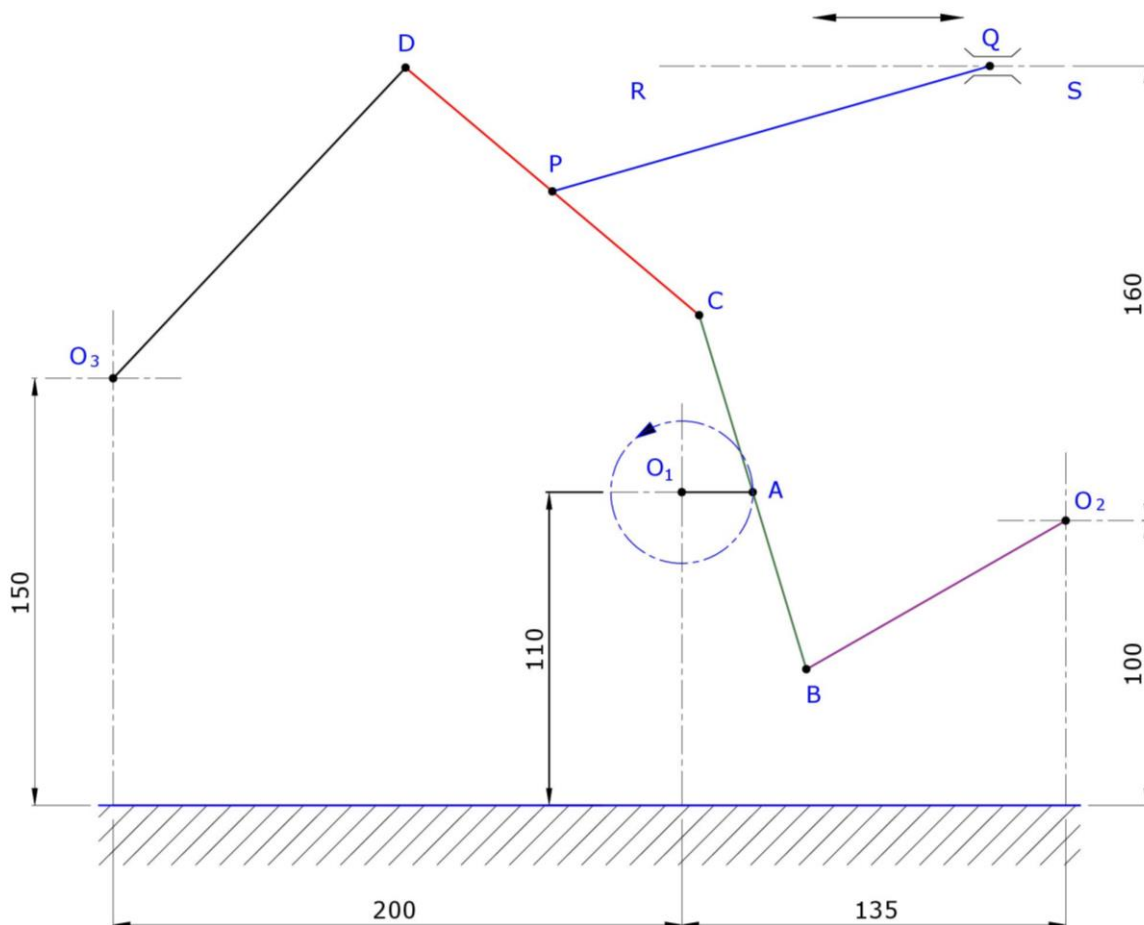

Figure 3

Question 4.

Figure 4a on the right shows an 'S' scroll consisting of two Archimedean spirals joined by means of a common tangent.

Figure 4b shows details of the starting lines.

You are requested to:

- a) copy the starting lines of Archimedean spiral 1; (2)
- b) construct 11/12 of a convolution of an Archimedean spiral starting from point A and ending at point B; (6)
- c) calculate and construct a normal and a tangent to the Archimedean spiral at point B (show calculations); (6)
- d) draw tangent BC 95 mm long; (1)
- e) locate, by construction, centre O_2 of Archimedean spiral 2; (1)
- f) complete the second 11/12 of a convolution of an Archimedean spiral from point C to point D. (4)

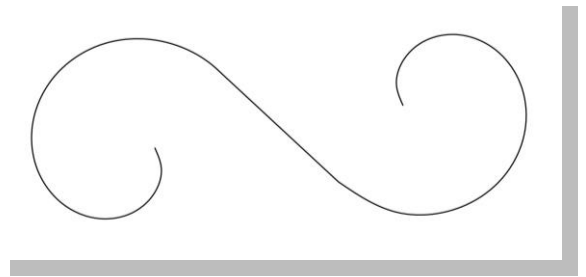
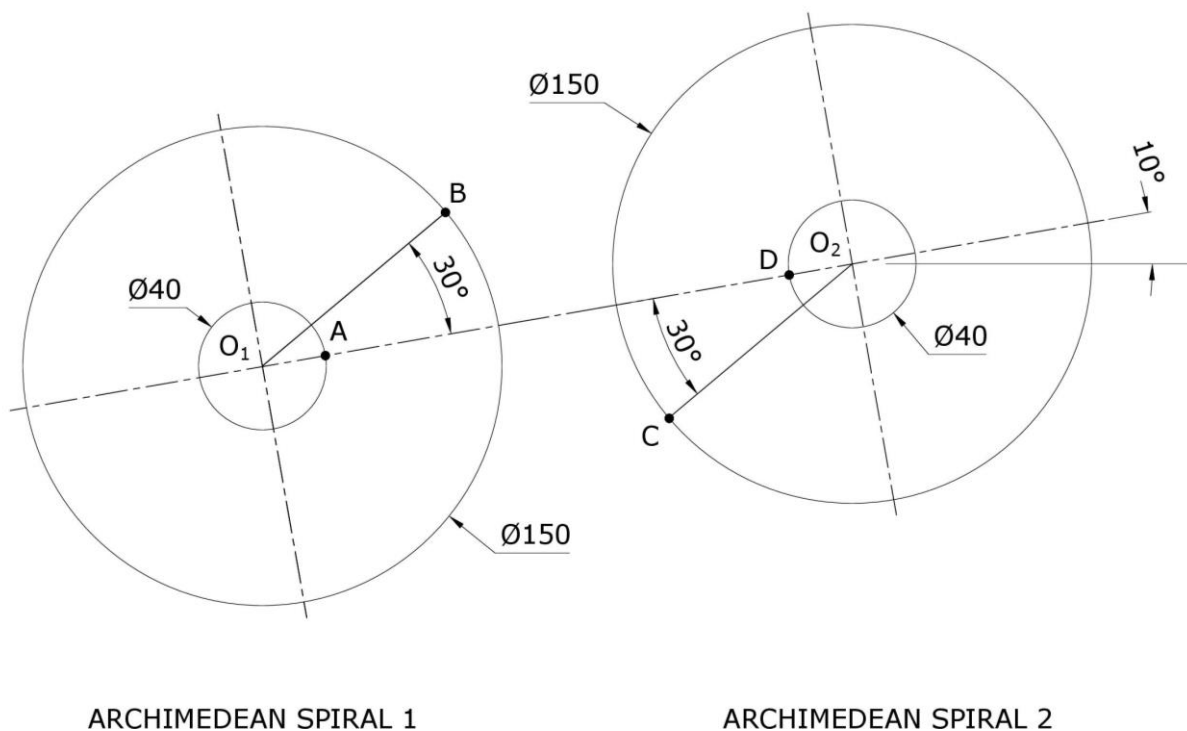

Figure 4a

(Total 20 marks)



ARCHIMEDEAN SPIRAL 1

ARCHIMEDEAN SPIRAL 2

Figure 4b

Please turn the page.

Question 5.

Figure 5a shows an illustration of a custom shaped funnel. The funnel consists of an inverted oblique cone pierced at the sides by a cylindrical hole and cut at the bottom to fit the corner of a square tank.

Figure 5b shows a dimensioned front elevation of the resulting oblique cone.

You are requested to:

- a) copy the given elevation; (2)
- b) determine, by construction, the true lengths of the generators of the oblique cone; (6)
- c) construct the surface development clearly showing the lower cut and the hole resulting from the intersection between the oblique cone and the $\varnothing 60$ cylinder. (12)

(Total 20 marks)

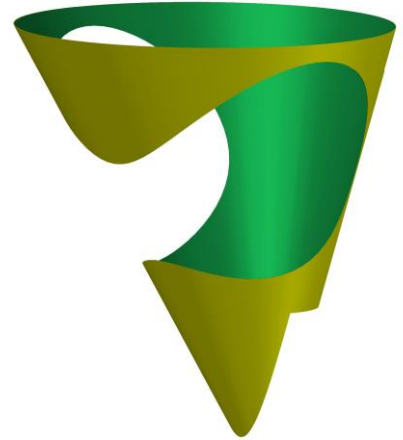

Figure 5a

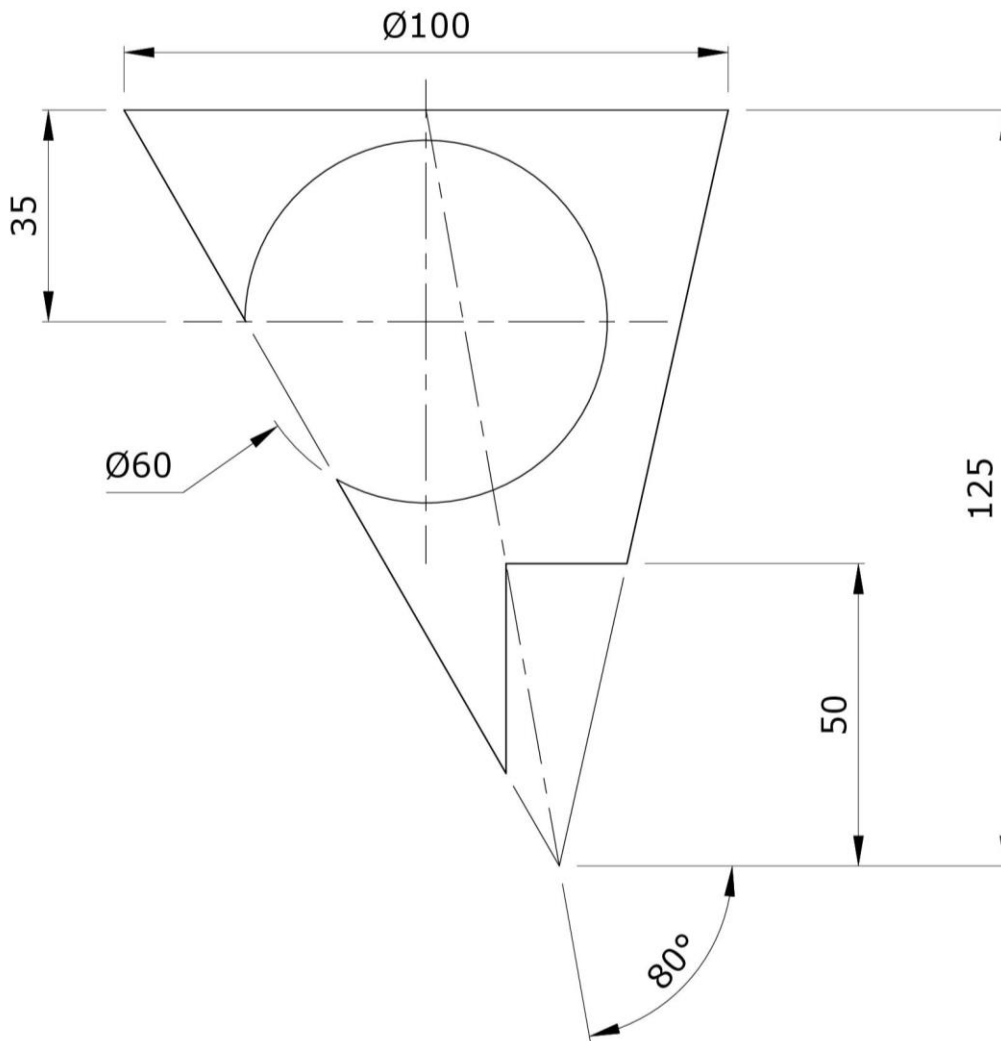

Figure 5b

Question 6.

An illustration of a semi-pentagonal gutter being intersected by a cylinder is given in Figure 6a.

An end elevation and an incomplete front elevation of the gutter and pipe are given in Figure 6b.

You are requested to:

- a) copy the given views; (5)
- b) project the curve of intersection in the front elevation; (6)
- c) draw the surface development of the gutter, including the resulting hole; (4)
- d) draw the surface development of the branch cylindrical pipe. (5)

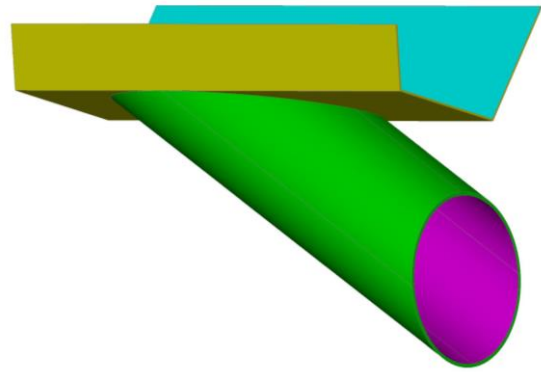

Figure 6a

(Total: 20 marks)

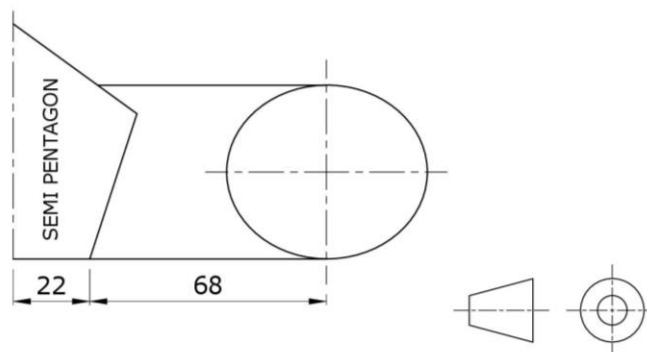
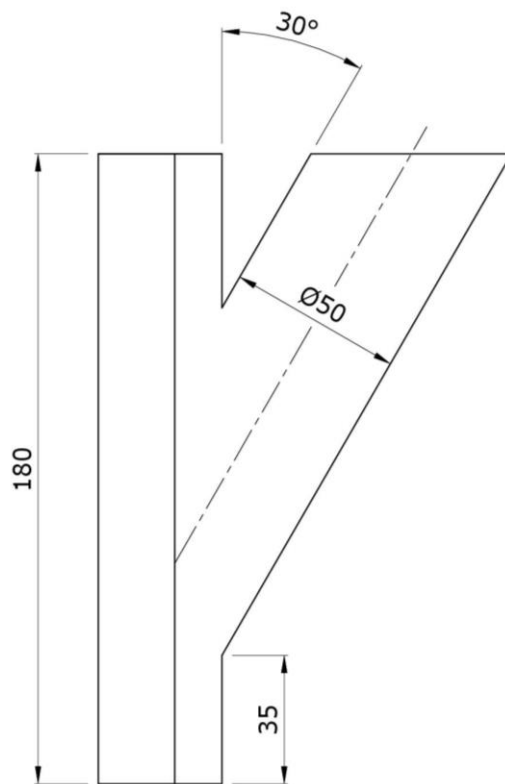

Figure 6b

Please turn the page.

Question 7.

An elevation and a plan of two lines skew are given in Figure 7. You are requested to:

- a) copy full size the given orthographic views; (3)
- b) draw an auxiliary elevation showing the true length of line C-D; (3)
- c) measure and state the true length of line C-D; (1)
- d) determine and state the length of the shortest connector between lines A-B and C-D; (10)
- e) locate the position of the shortest connector in all views. (3)

(Total: 20 marks)

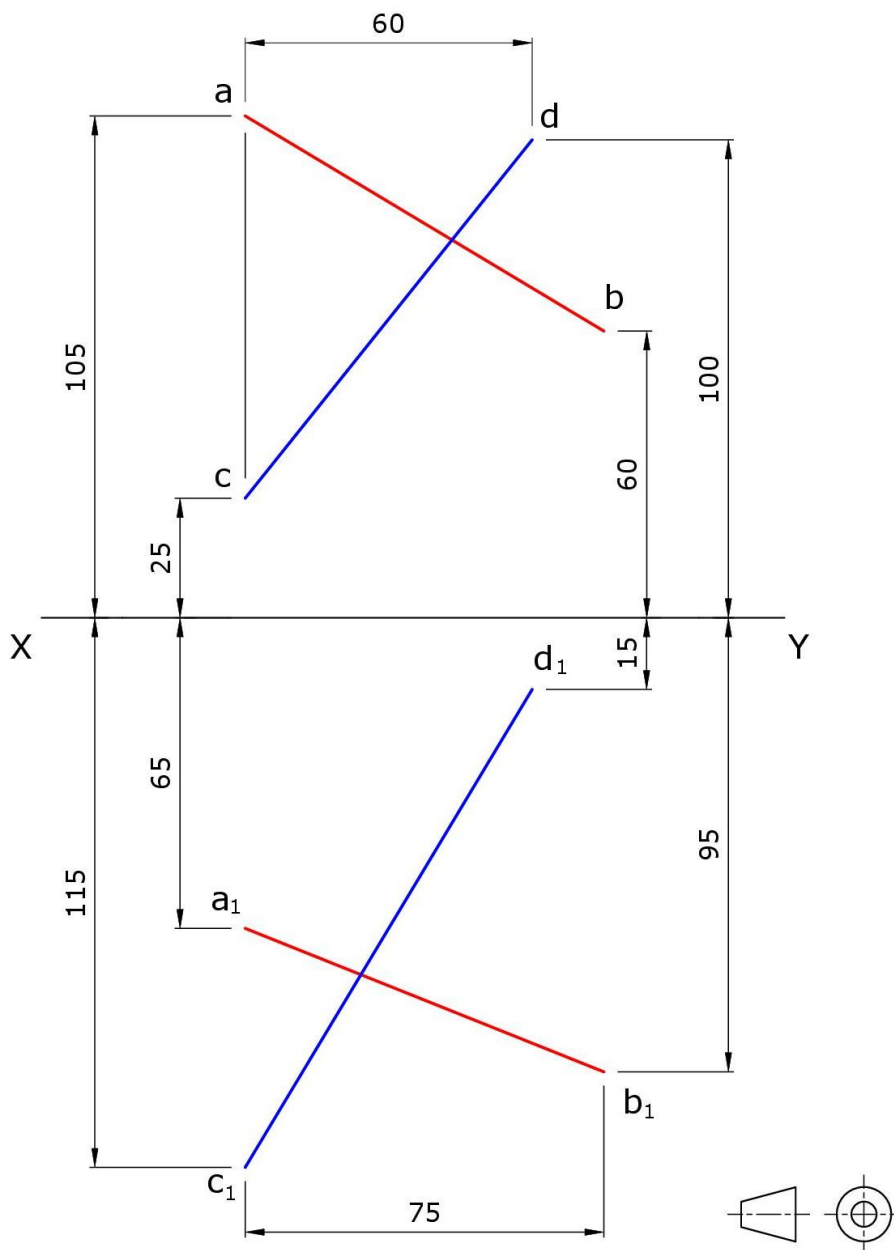

Figure 7

Question 8.

A cantilever 4.5 m long, securely built-in at the wall, carries a partial uniformly distributed load of 3 kN per metre and, in addition, two concentrated loads of 5 kN and 2 kN as shown in Figure 8. You are requested to:

- a) copy the space diagram of the cantilever using a scale of 40 mm representing 1 metre; (2)
- b) label the diagram by using the Bow's notation; (1)
- c) draw the polar diagram, using a scale of 10 mm representing 1 kN and a polar distance of 120 mm; (5)
- d) draw the shear force diagram; (5)
- e) construct the bending moment diagram and print the length of the closer on the funicular polygon; (5)
- f) write the ordinate scale for the bending moment diagram; (1)
- g) state the nature and magnitude of the greatest bending moment. (1)

(Total: 20 marks)

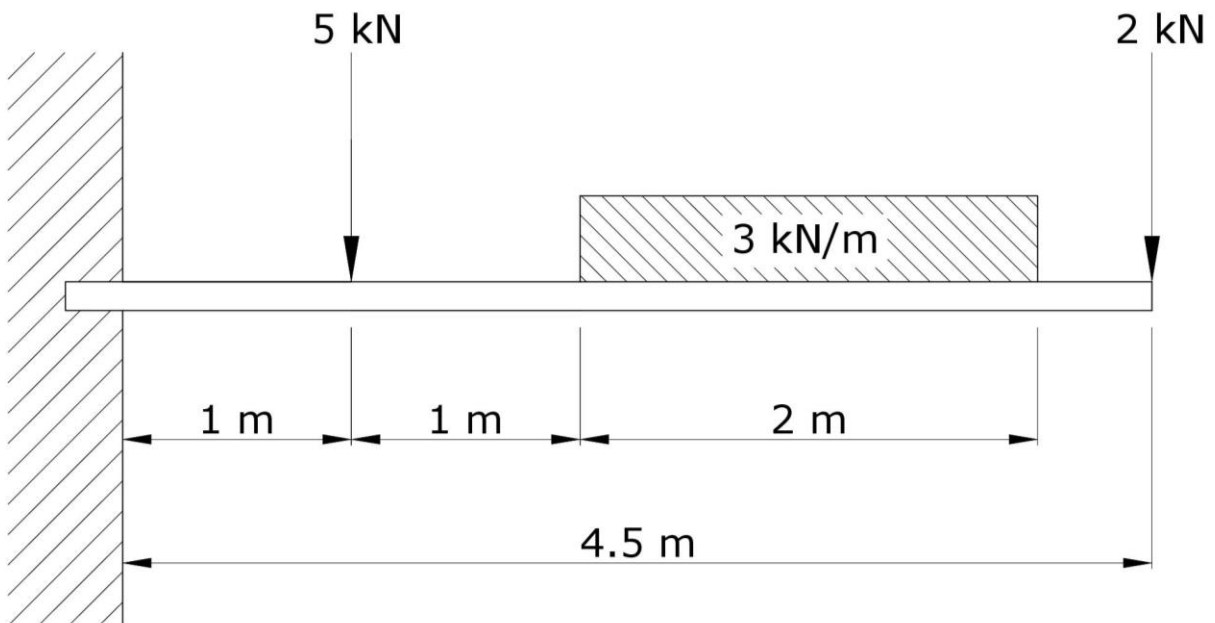

Figure 8



SUBJECT:	Engineering Drawing
PAPER NUMBER:	II
DATE:	31 st May 2022
TIME:	4:00 p.m. to 7:05 p.m.

Directions to Candidates

Write your index number where indicated at the top of all drawing sheets.

Attempt **Question 1** and any other **TWO** questions.

Programmable calculators **cannot** be used.

Unless otherwise stated:

- drawings should conform to B.S. or equivalent (ISO) standards;
- all dimensions are in millimetres;
- all answers are to be accurately drawn with instruments;
- all construction lines must be left on each solution;
- drawing aids may be used.

Dimensions not given should be estimated using engineering judgement.

Careful layout and presentation are important.

Marks will be awarded for accuracy, clarity and appropriateness of constructions.

Mark allocations are shown in brackets.

Question 1 carries 60 marks. Questions 2, 3, 4 and 5 carry 20 marks each.

Question 1.

An exploded view of a Manual Tailstock is shown in Figure 1a.

Detailed drawings of the components of the tailstock are given in Figures 1b and 1c on the attached A 3 papers.

The components of the tailstock may be assembled as follows.

- The main body (Item 1) of the tailstock is secured to the lathe table by means of two M16 bolts (not presented on the drawing).
- An L-shaped key (Item 2) is to be inserted in the key slot of the bore of the body.
- The M42 threaded end of the end cover (Item 3) is screwed into the M42 internal thread of the body and secured tightly by means of a 48 mm across flats spanner.
- The 38 mm outside diameter of the spindle (Item 4) slides inside the $\text{\O}38$ mm bore of the main body. The $\text{\O}19$ mm end portion of the spindle is inserted through the $\text{\O}19$ mm hole of the cover.
- The 11 mm thick lower end of the lever (Item 5) is fitted in the 11 mm wide groove between the lug webs of the body, with the $\text{\O}10$ mm hole of the lever, lined in with the $\text{\O}10$ mm hole of the lug webs.
- The 31 mm x $\text{\O}10$ mm fulcrum pin (Item 6) is inserted in the $\text{\O}10$ mm aligned holes of the lever and the body enabling the lever to swing forward and backward.
- The 11 mm wide across flats sides of the spindle is inserted through the 11 mm wide rectangular hole of the lever.
- A 25 x $\text{\O}10$ mm fulcrum pin (Item 7) inserted in the elongated hole of the lever and in the $\text{\O}10$ mm hole of the spindle, secures the lever to the spindle.
- The tapered centre end (Item 8) is pressed in the recessed tapered hole of the spindle.
- The diameter 'D' of the recessed taper hole is to be determined from diameter 'D' of the centre (Item 8).

With the tailstock fully assembled, draw the following views, full size, omitting hidden detail.

a) A full sectional view of the arrangement taken on the cutting plane X-X. Show the front part of the spindle (item 4) as a local section to clearly illustrate the tapered hole, the key and key slot, and the air hole. (45)

b) A complete view looking in the direction of the arrow A. Do not show hidden details. (15)

Note:

- Show the lever in the vertical position.

(Total: 60 marks)

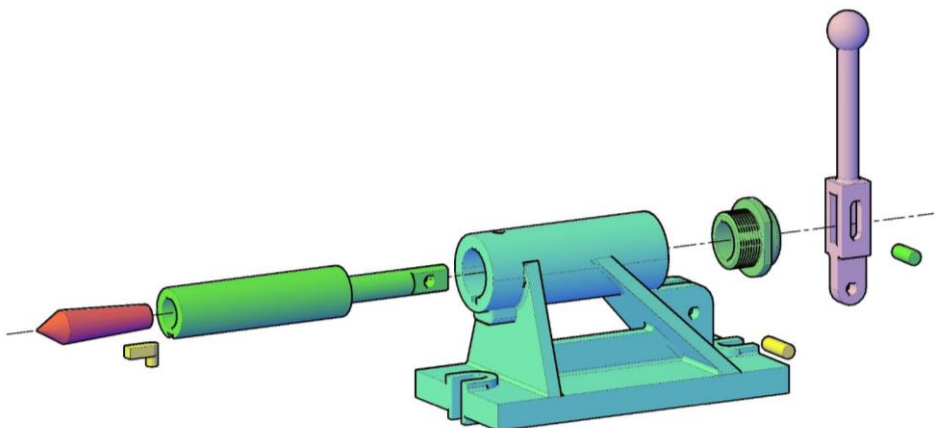

Figure 1a

Question 2.

A castle nut is a positive locking device that is used to ensure that, when it is affixed to a bolt by means of a cotter split pin, it resists vibration and will not loosen. A hole, the size of a slot in the castle nut, is drilled perpendicular to the axis of the bolt. A cotter pin is inserted into the hole and bent on each side of the nut.

Orthographic views of the bolt, the castle nut, the twist drill, and the cotter pin, are given in Figure 2.

You are requested to draw two freehand pictorial and informative sketches to illustrate:

- a) how the bolt is drilled after the castle nut is screwed in the required position; (10)
- b) how the cotter pin is bent on each side of the nut. (10)

Notes:

- Enhance your sketches by adding annotations and motion arrows.
- The sketches are to be drawn approximately full size.

(Total: 20 marks)

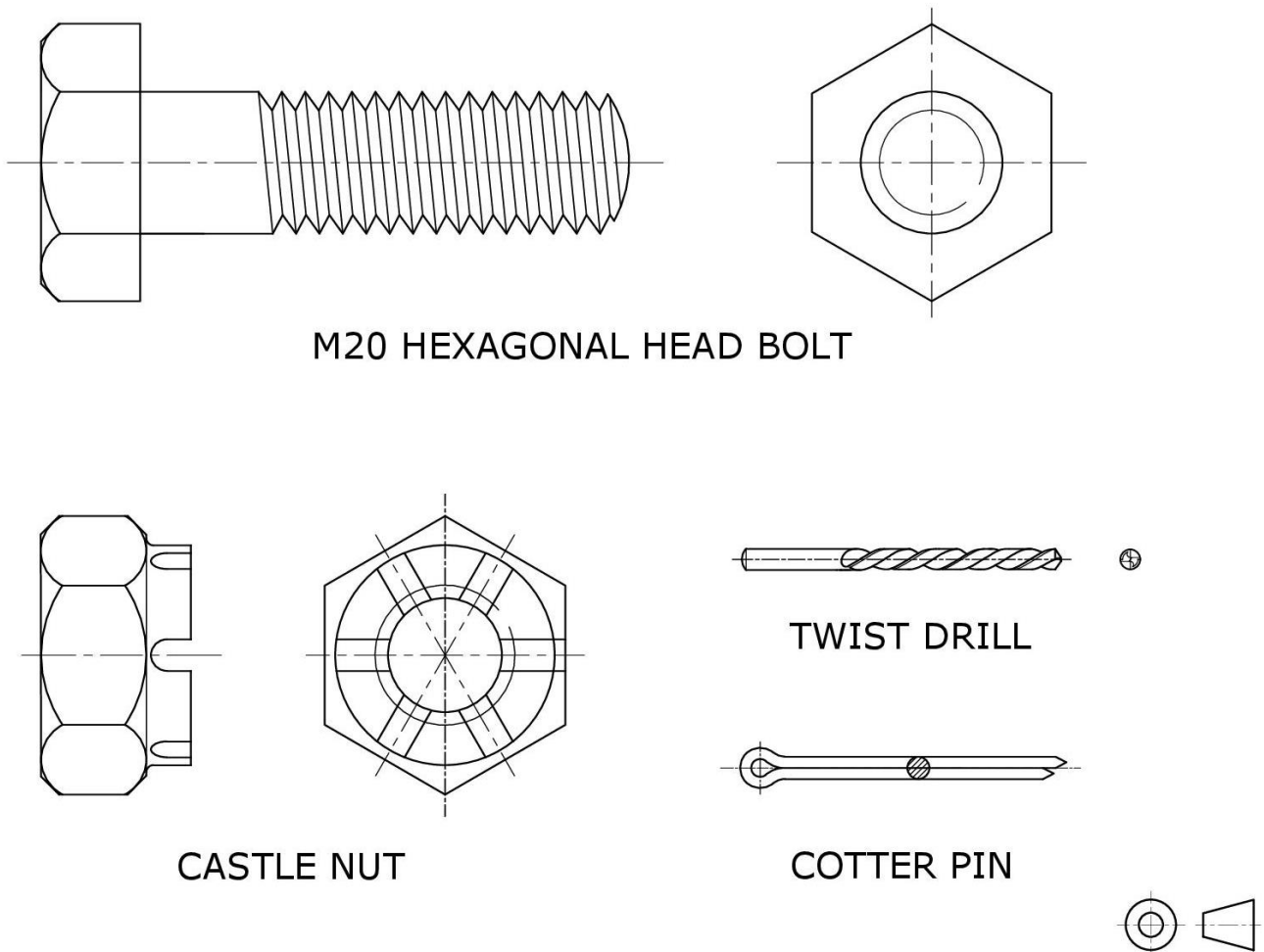
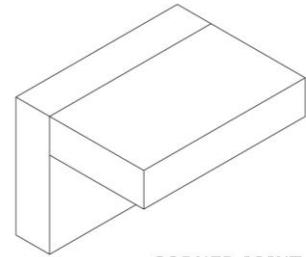

Figure 2

Please turn the page.

Question 3.

a) Welding is a fabrication process whereby two or more metal parts are fused together by means of heat. The five basic ways of arranging the metal pieces so that these can be joined by welding are Corner joint, Butt joint, Lap joint, Edge joint and T-joint. Figure 3a shows an illustration of a corner joint arrangement.



CORNER JOINT

Figure 3a

You are requested to draw pictorial freehand sketches to illustrate the other four above-mentioned joints. (8)

b) Welding Symbols are a graphical way of communicating information about a welding joint. These symbols and the method of conveying the required information are regulated by BS EN ISO 2553:2013. System A.

Figure 3b shows an isometric view of a fabricated shaft support bracket. In the illustration the welds are shown in a realistic manner.

- The base is welded to the vertical member by an all-around fillet weld having a convex surface.
- The circular boss is welded to the vertical member by an all-around fillet weld having a concave surface.
- Finally, the base is welded **on field** to a base extension by a double V butt weld having a flash surface.

You are requested to:

- i. draw **THREE** orthographic views of the shaft support bracket; (4)
- ii. label **all** the welded joints by the standard conventions used. (8)

Note:

- The material thickness of the sketches (a) and the orthographic views (b) is approximately 15 mm. The other dimensions are to be estimated while maintaining the correct proportions.

(Total: 20 marks)

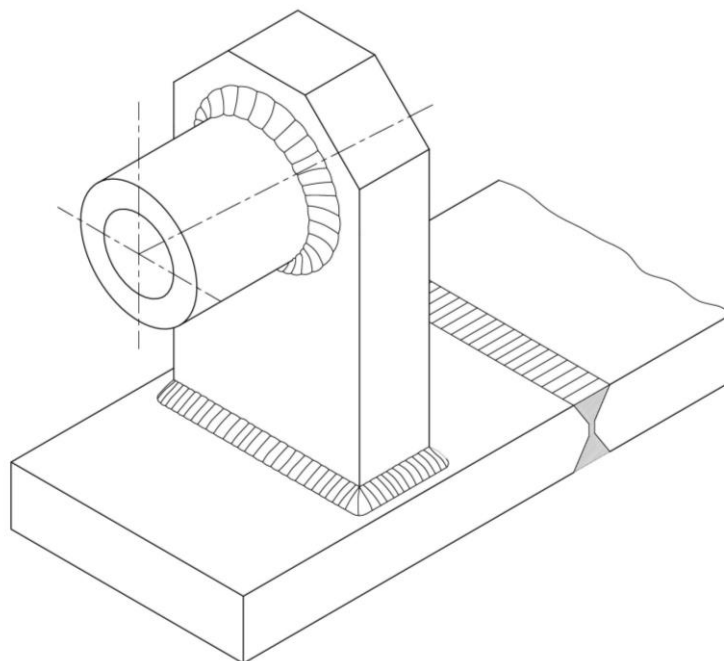

Figure 3b

Question 4.

A sectioned view of an inlet valve and guide assembly is show in Figure 4a and 4b.

- The bush is installed in the casting block to an interference drive fit of $\text{Ø } 36 \text{ H7/s6}$.
- The valve stem runs in the guide to a clearance free running fit of $\text{Ø } 10 \text{ H9/d10}$.
- The guide is installed in the casting to an interference press fit of $\text{Ø } 15 \text{ H7/p6}$.

Table 1 below shows a selection of ISO fits used in the assembly.

- Draw detailed sectional drawings of each separate item; the **casting block**, the **bush**, the **guide**, and the **valve** (estimate any missing dimensions). (8)
- Show one important dimension on each of the detail drawings. (2)
- Present the lower- and upper-dimension values of the inner and outer diameters. (10)

Notes:

- Refer to Table 1 to obtain the correct value of tolerance and give the actual limits of size.
- Show the calculations and workings of the limits below the detailed drawings.

(Total: 20 marks)

Table 1

Selected ISO Fits – Hole Basis													
Diameter steps (in mm)		Limits of Tolerance											
		Values of tolerance in μm ($1\mu\text{m} = 0.001\text{mm}$)											
NOMINAL SIZE		H7		H8		H9		d10		p6		s6	
Over	Up to and including	Upper	Lower	Upper	Lower	Upper	Lower	Upper	Lower	Upper	Lower	Upper	Lower
6	10	+015	0	+22	0	+36	0	-40	-98	+024	+015	+032	+023
10	18	+018	0	+27	0	+43	0	-50	-120	+029	+018	+039	+028
18	30	+021	0	+33	0	+52	0	-65	-149	+035	+022	+048	+035
30	50	+025	0	+39	0	+62	0	-80	-180	+042	+026	+059	+043

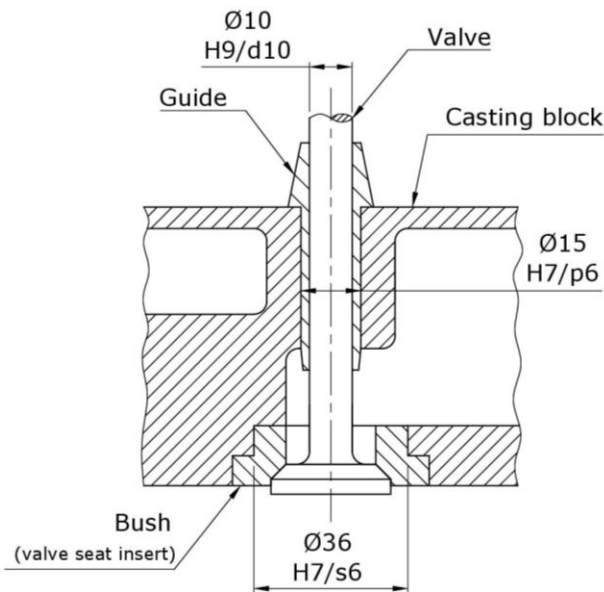

Figure 4a

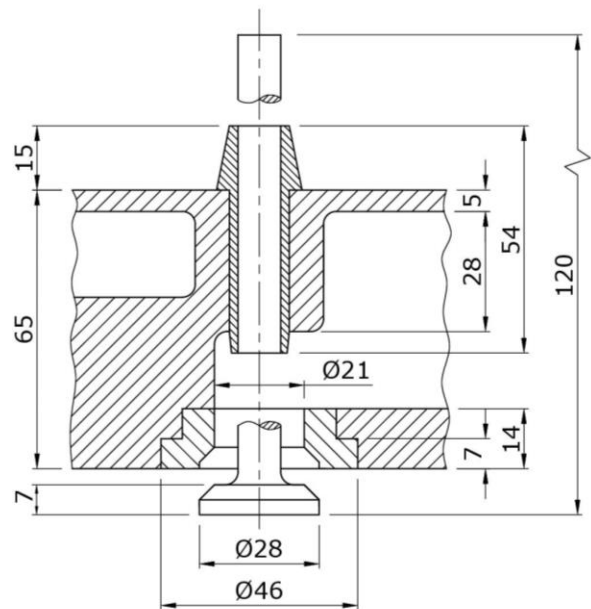

Figure 4b

Please turn the page.

Question 5.

Dimensioning is a means of defining the exact amount of material remaining after a series of manufacturing operations have taken place. Dimension lines are used to indicate the extent of a given dimension. Refer to the illustrations given in Figure 5 to complete the following:

- i. Draw a 120 mm diameter circle representing the face of a hub. Four M12 bolt holes are to be equally spaced on the hub. The centres of the holes are to be on a pitch circle diameter of 90 mm. The holes are to be positioned 45° on each side of the shown centerline. The 48 mm diameter bore of the hub has a keyway which is to be assembled with an 8 mm square section key, inserted between the hub and the shaft in the axial direction. Complete the drawing by showing the shaft and key. Include **all** dimensions. (6)
- ii. Present a sectional elevation of a dimensioned drilled and tapped blind hole for an M20 thread in a 70 mm thick plate. Complete the view by including the dimensions. (3)
- iii. A countersink hole is to be machined on the 40 mm thick plate. The inner drilled through hole is 14 mm in diameter and the countersink depth is 10 mm. Draw a dimensioned sectional view of the countersink hole. Include countersink angle and diameter at the surface. (3)
- iv. Draw the dimensions on the tapered shaft for a woodruff key. The 80 mm diameter shaft has an included angle of 20° for a length of 100 mm. The other end of the shaft is 45 mm diameter with a 5 mm x 5 mm stepped recess. The woodruff key formed from a segment of the 60 mm diameter disc, is to fit in the circular recess of the tapered shaft for a depth of 10 mm. Show the circular recess as a local section. (8)

(Total: 20 marks)

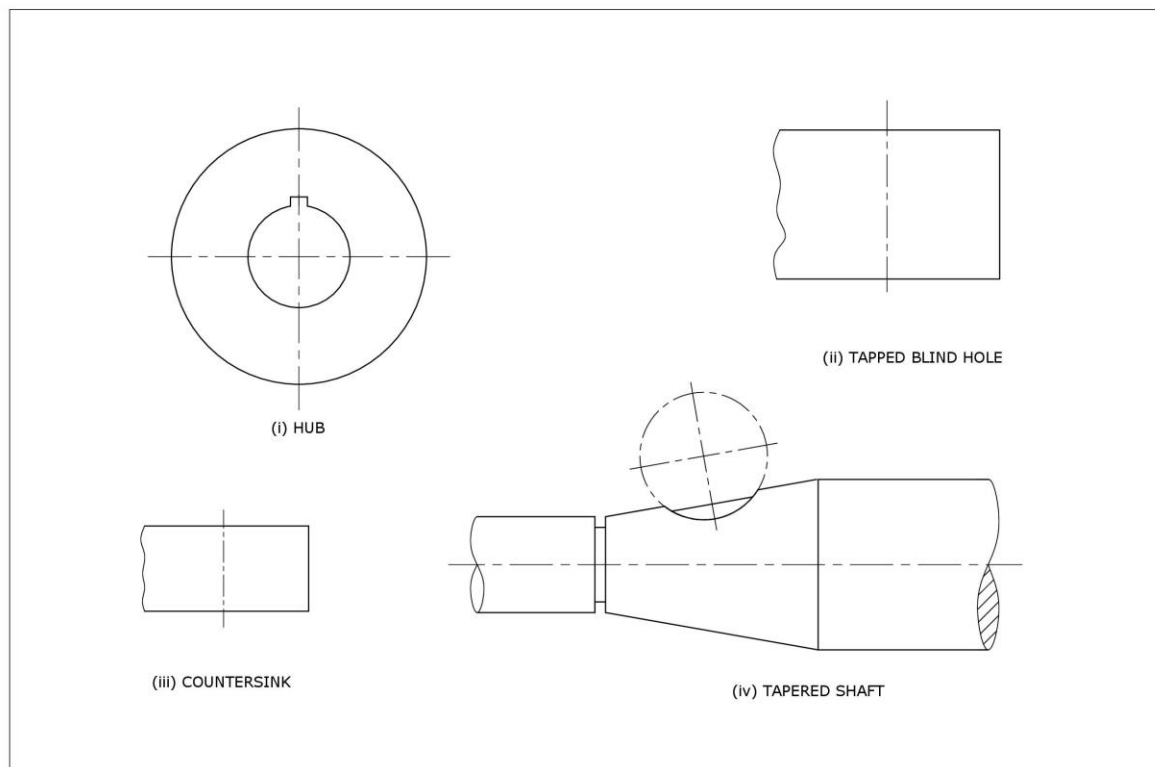
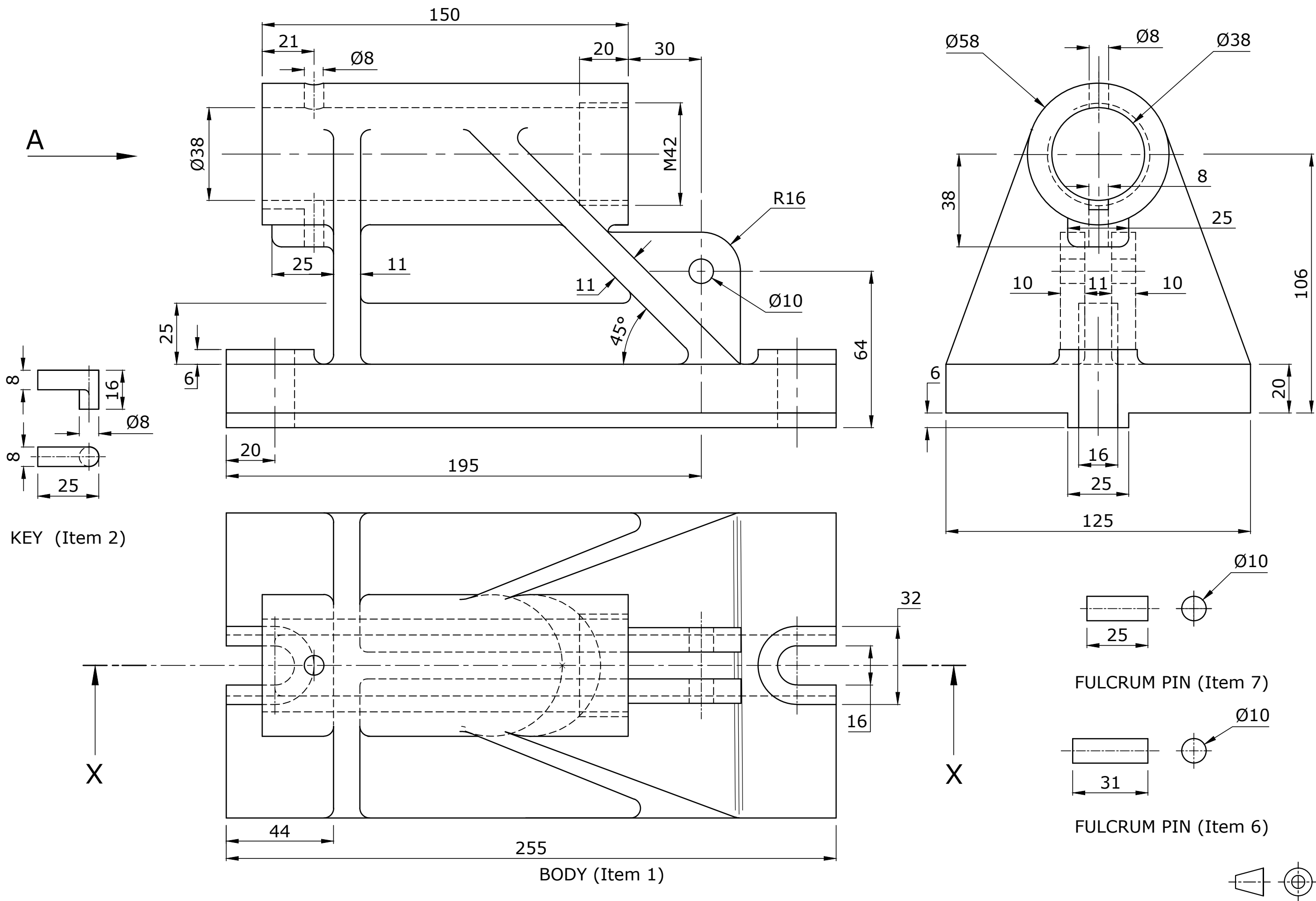
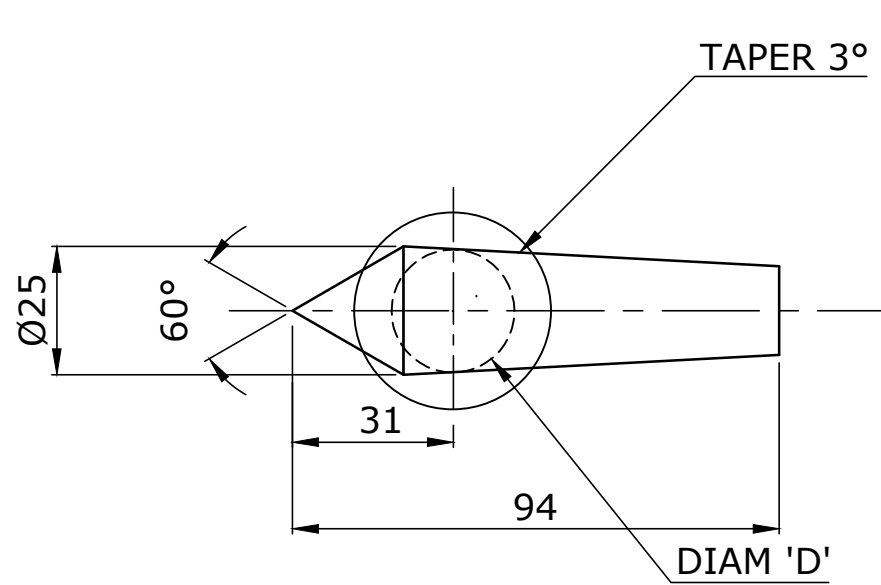
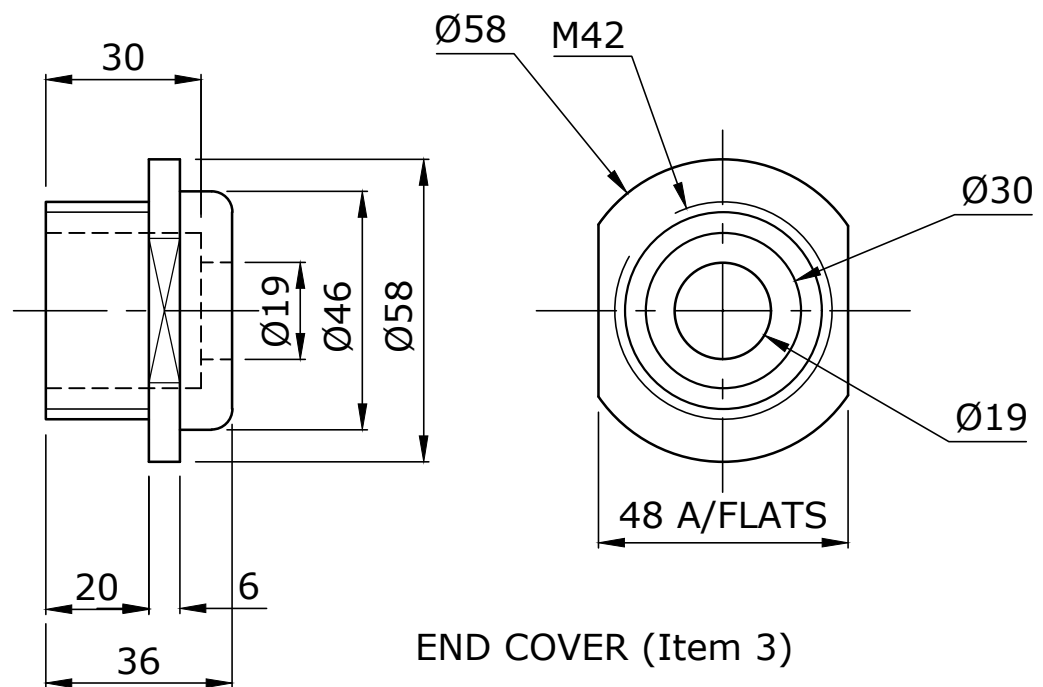

Figure 5





CENTRE (Item 8)



END COVER (Item 3)

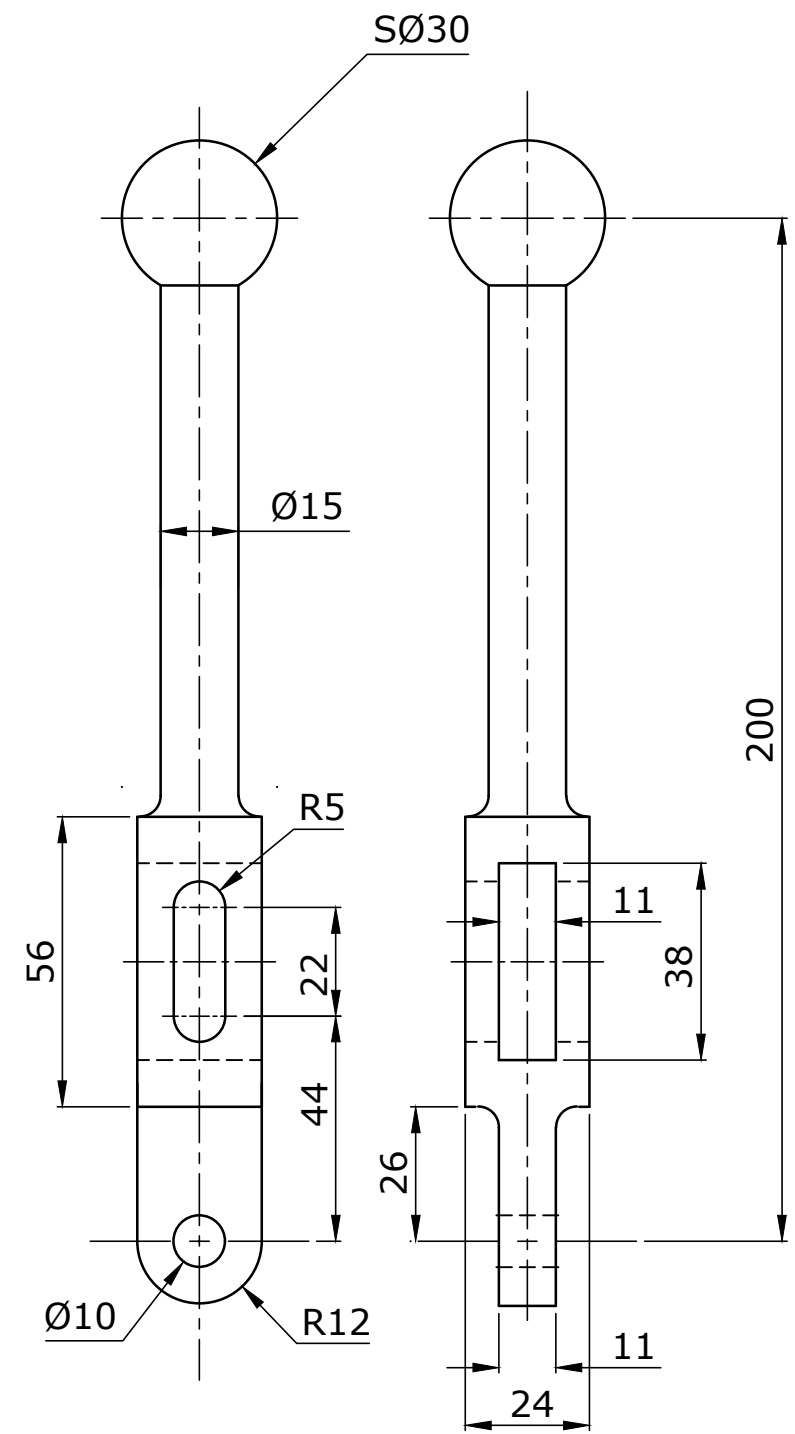

LEVER (Item 5)

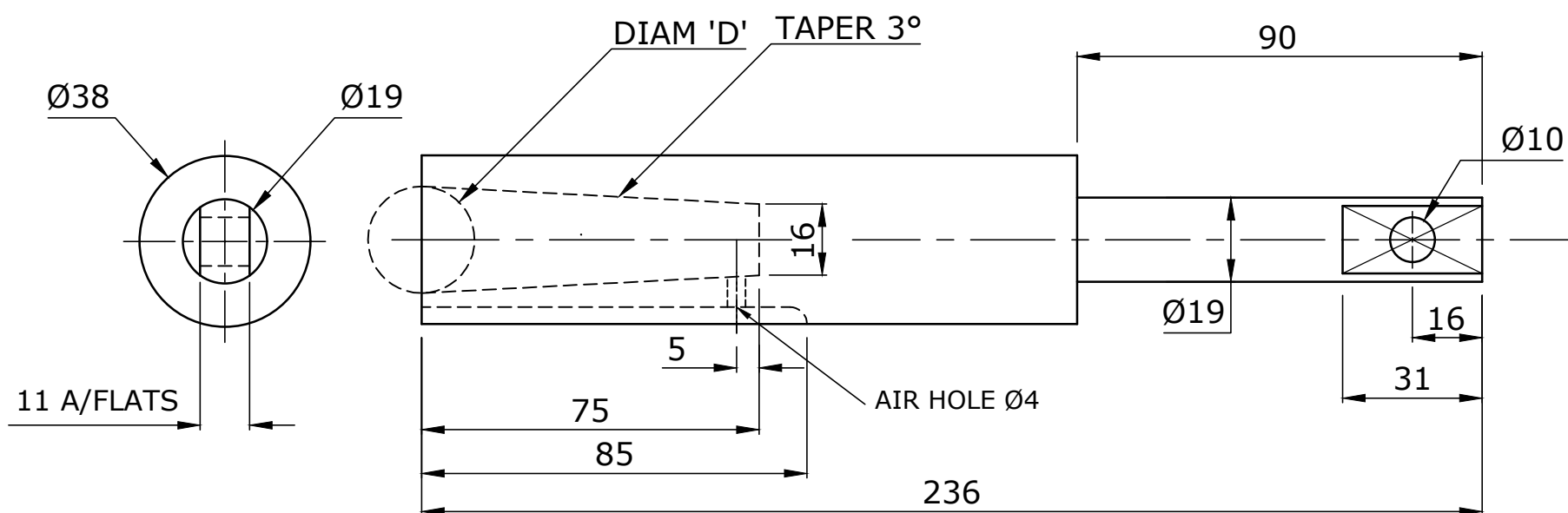

SPINDLE (Item 4)

