



---

SUBJECT:	<b>Engineering Drawing/Graphical Communication</b>
PAPER NUMBER:	I
DATE:	8 <sup>th</sup> June 2023
TIME:	9:00 a.m. to 12:05 p.m.

---

### **Directions to Candidates**

Write your index number where indicated at the top of all drawing sheets.

Attempt any **FIVE** questions.

Programmable calculators cannot be used.

Unless otherwise stated:

- a. drawings should conform to B.S or equivalent (ISO) standards;
- b. all dimensions are in millimetres;
- c. all answers are to be accurately drawn with instruments;
- d. all construction lines must be left in each solution;
- e. drawing aids may be used.

Dimensions not given should be estimated.

Careful layout and presentation are important.

Marks will be awarded for accuracy, clarity and appropriateness of constructions.

**Question 1.**

The illustration in Figure 1a shows a transition piece designed to connect a cylindrical inlet to a square outlet.

Use the dimensions given in Figure 1b to:

- a. copy the given views; (2)
- b. construct a half-surface development of the cylinder; (4)
- c. construct the necessary true lengths; (4)
- d. construct a full surface development of the transition piece 'A'. (10)

Note: take the given J-J line as the seamline.

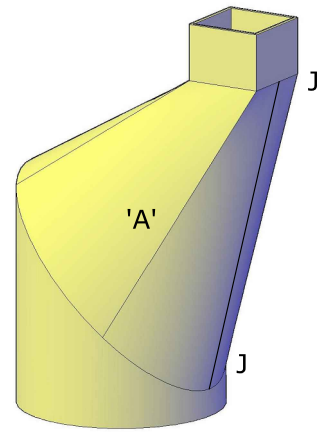

Figure 1a

**(Total: 20 marks)**

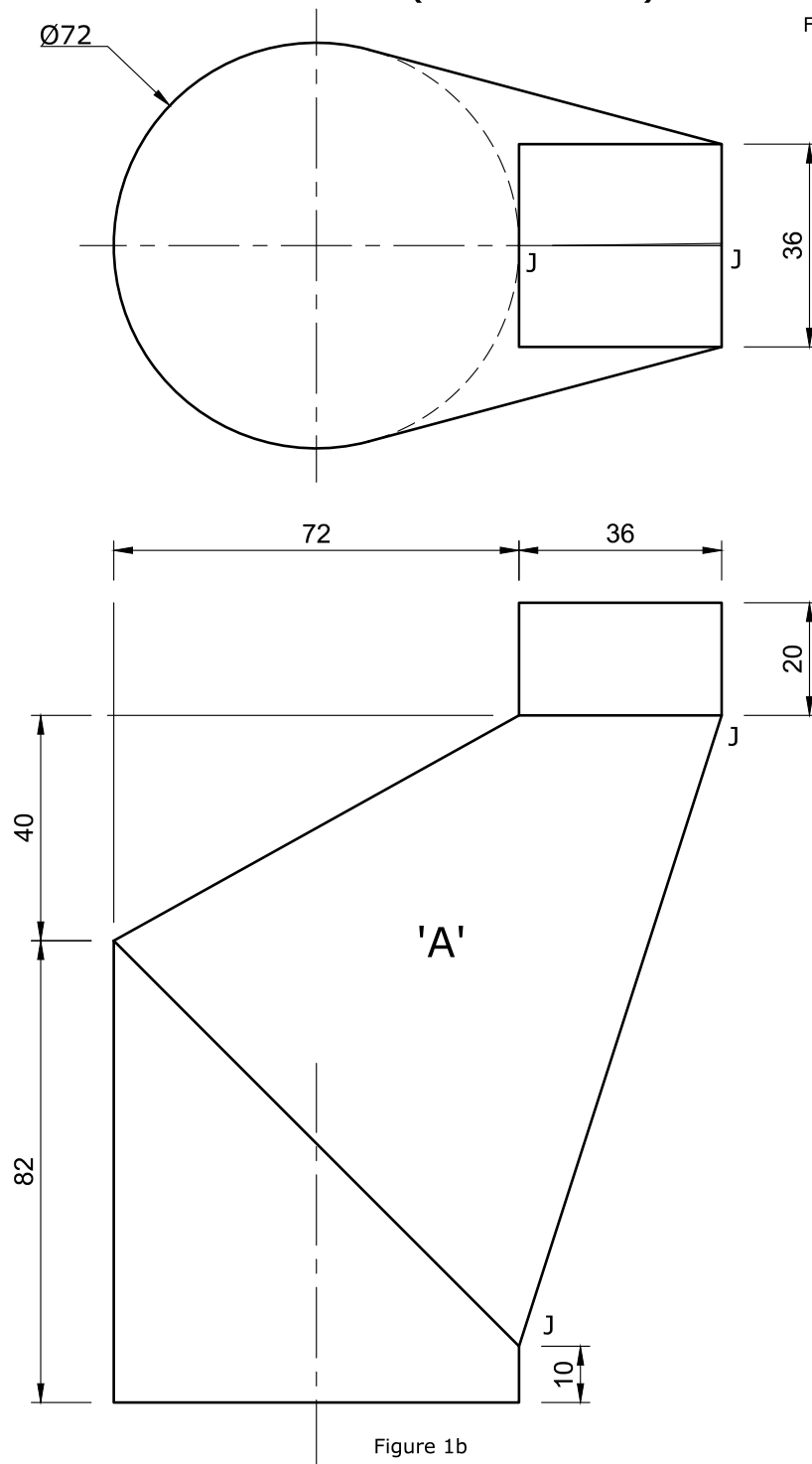

Figure 1b

**Question 2.**

Figure 2a shows a right cone intersected by an offset cylinder at an angle of 15° to the horizontal plane. Details of the intersected solids are given in the incomplete orthographic views in Figure 2b.

You are requested to:

- a. copy the given orthographic views; (2)
- b. project an auxiliary plan in order to plot the curve of intersection on the front elevation; (6)
- c. project the curve of intersection and complete the front elevation; (6)
- d. project the curve of intersection and complete the plan. (6)

Note: Show hidden details.

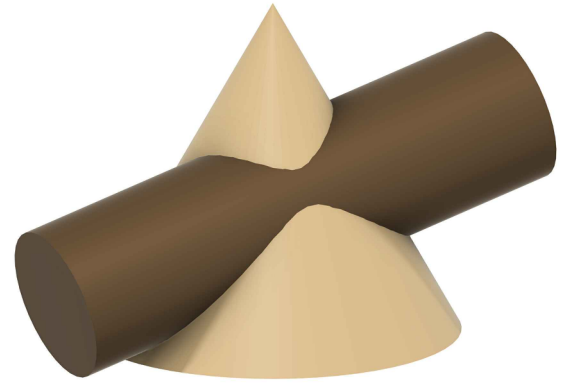

Figure 2a

**(Total: 20 marks)**

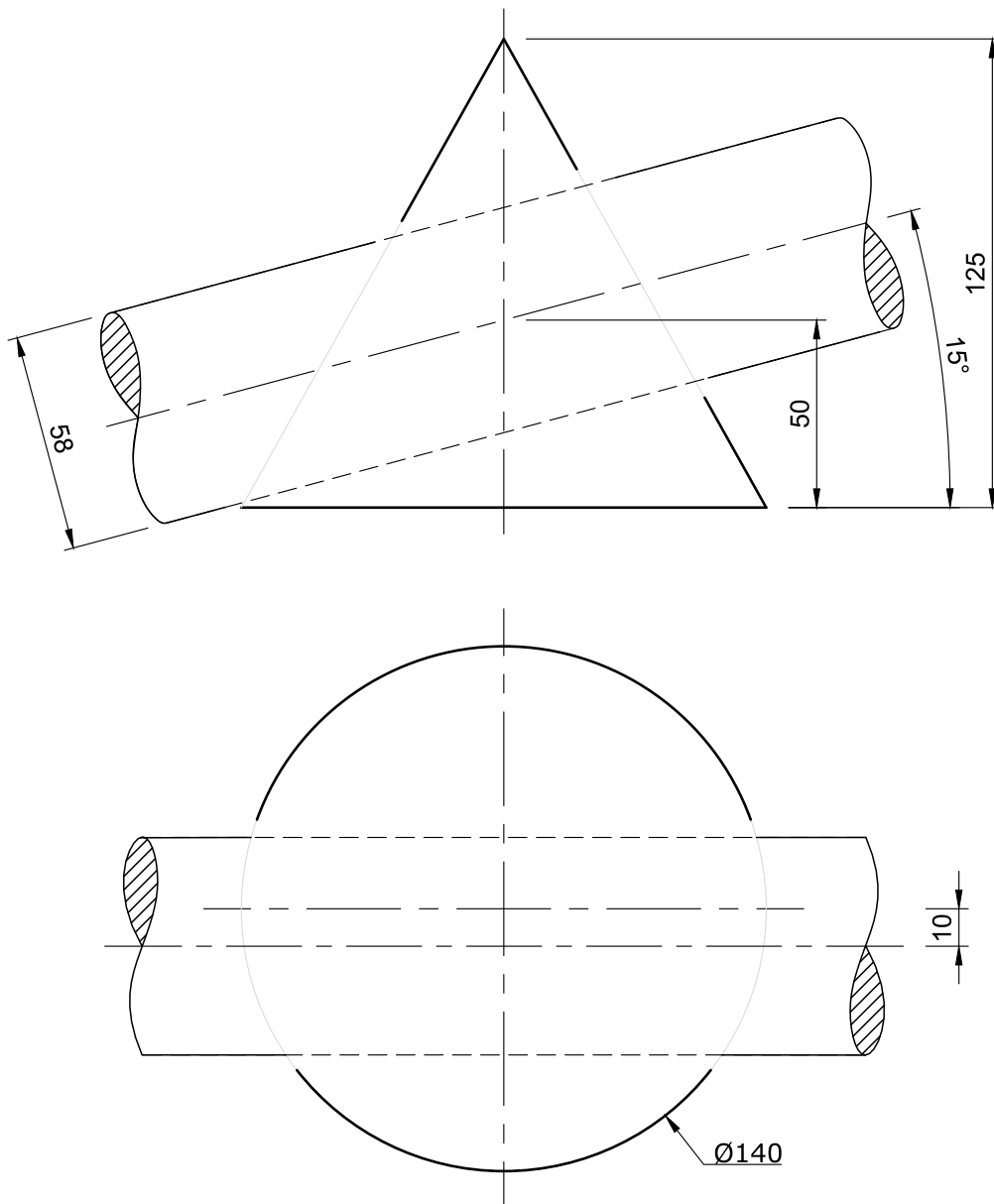
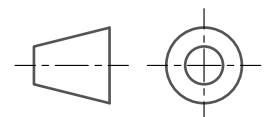

Figure 2b



**Question 3.**

An illustration of a wooden blocks arrangement is given in Figure 3a. Two dimensioned orthographic views of the arrangement are given in Figure 3b.

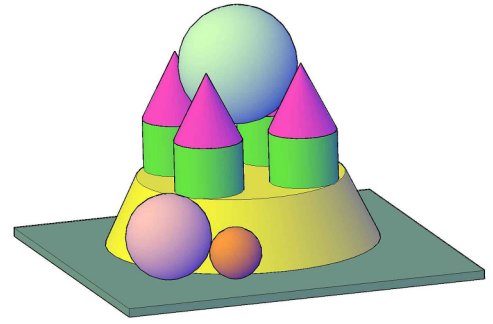

Figure 3a

- Four equispaced  $\text{Ø}40$  mm cylinders with a conical cap are fixed on the top of a frustum of a right cone.
- Sphere **A**, of unknown diameter is resting tangentially between the four conical caps. The top of the sphere is to be 140 mm above the horizontal plane.
- Sphere **B**, also of unknown diameter, is resting on the horizontal plane and tangential to the frustum at point P.
- The smallest sphere **C** ( $\text{Ø}30$  mm) is resting on the H.P. and is in mutual contact with sphere **B** and the frustum.

You are requested to:

- copy the given views; (2)
- determine, by construction, the diameter of sphere A, tangential with the four conical caps; (4)
- draw the sphere in position and state the diameter of sphere A; (1)
- determine, by construction, the diameter of sphere B; (2)
- draw sphere B in position and state its diameter; (2)
- draw, by construction, the  $\text{Ø}30$  mm sphere C; (3)
- indicate the points of contacts in **all views**; (3)
- draw the hidden details and line in the visible details, in both views, with a bold outline. (3)

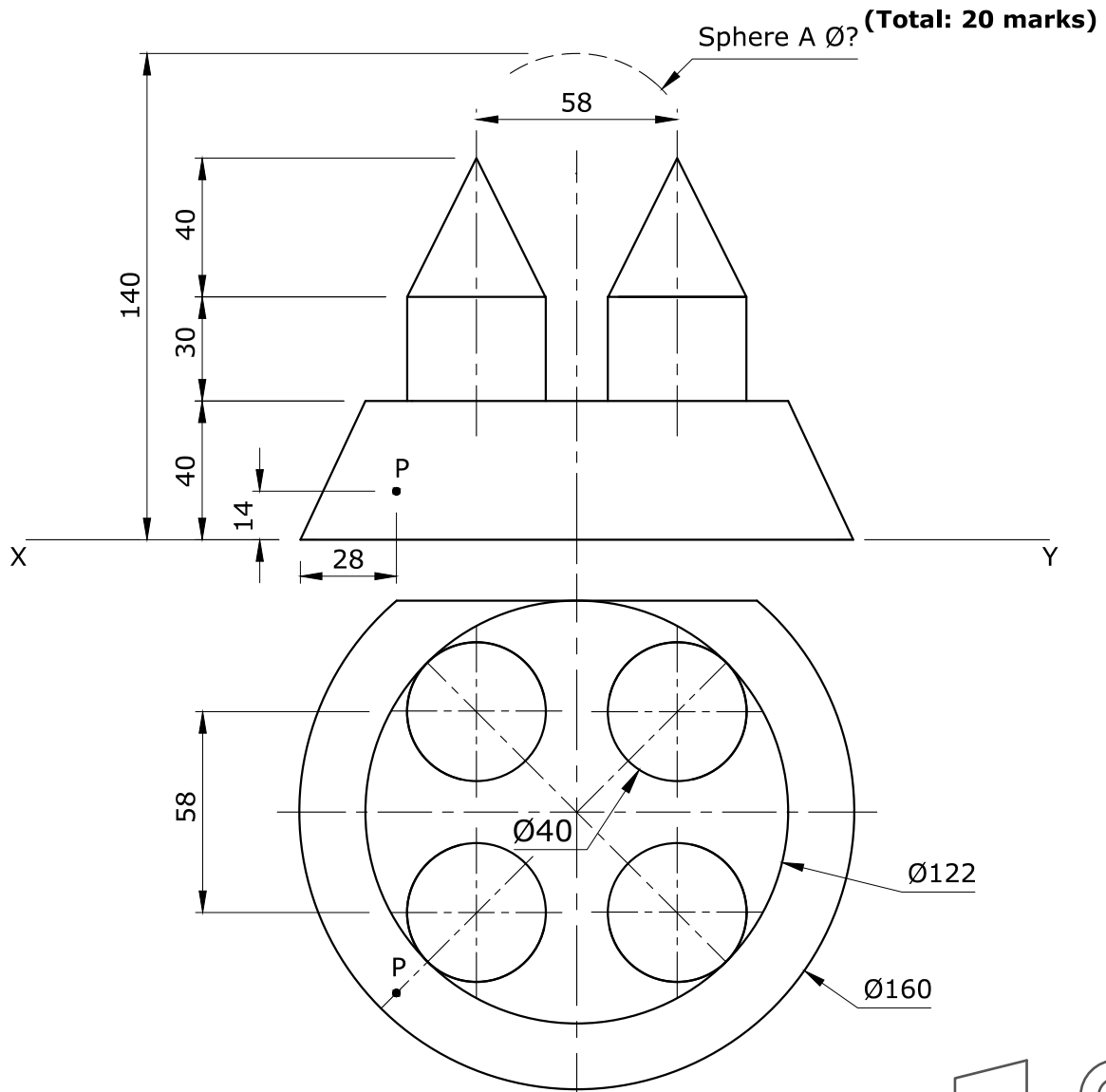

Figure 3b  
Page 4 of 7

**Question 4.**

Figures 4a and 4b show two intersecting triangles ABC and DEF.

Using a scale of 1:1, you are requested to:

- copy the given views; (2)
- project an auxiliary elevation showing one of the triangles as an edge view to locate the points of intersection; (4)
- project the points of intersection to complete the plan and front elevation of the two triangles; (4)
- project an auxiliary view of the two triangles showing the line of intersection as true length; (3)
- project a second auxiliary view showing the two triangles as two intersecting lines and state the dihedral angle between them; (3)
- project the true shape of both triangles. (4)

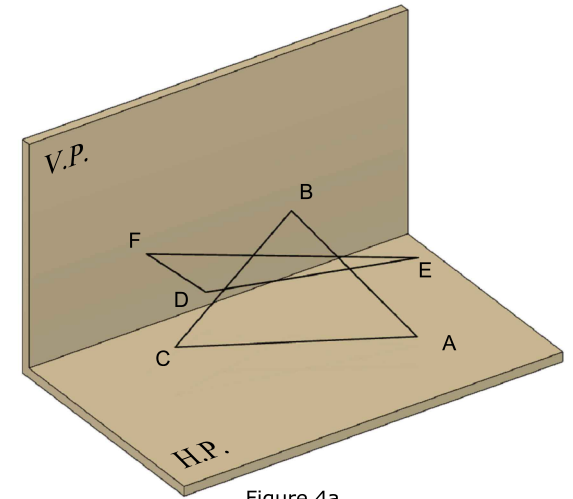

Figure 4a

**(Total: 20 marks)**

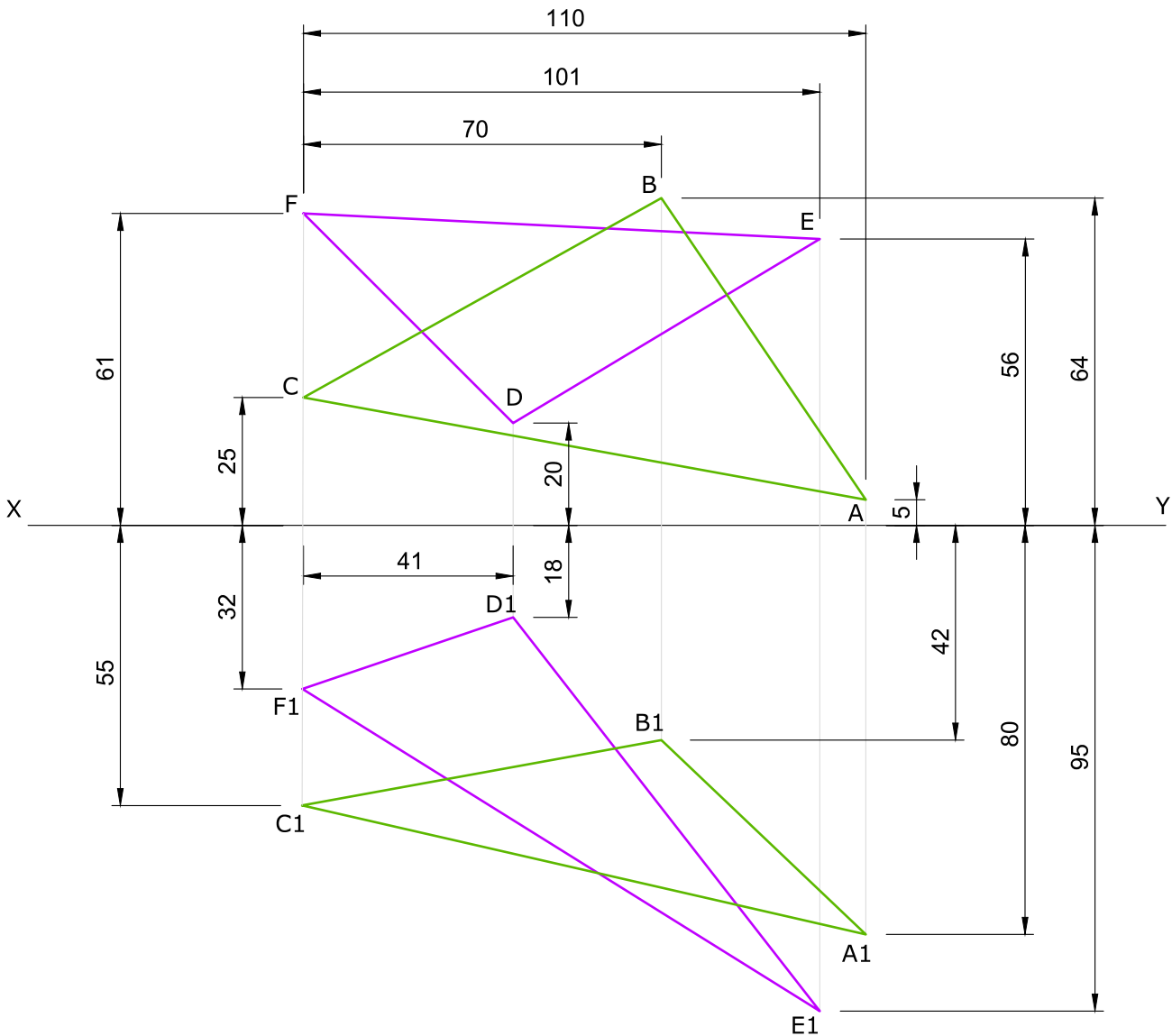
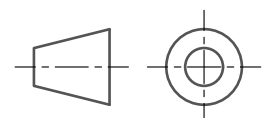

Figure 4b



**Question 5.**

Figure 5 describes a beam consisting of two parts which are hinged together. The hinged beam rests on three simple supports. You are requested to:

- a. draw Figure 5 and; (1)
- b. determine graphically:
  - i. the bending moment diagram; (6)
  - ii. the values of  $R_L$ ,  $R_M$  and  $R_R$ ; (3)
  - iii. the magnitude, nature and position of the greatest bending moment; (3)
  - iv. the positions along the beam where the bending moment is zero; (1)
  - v. the shear force diagram; (5)
  - vi. the magnitude of the shear force at the hinge. (1)

Notes:

- Space diagram scale: 10 mm = 1 m
- Vector diagram scale : 1 mm = 1 kN

**(Total: 20 marks)**

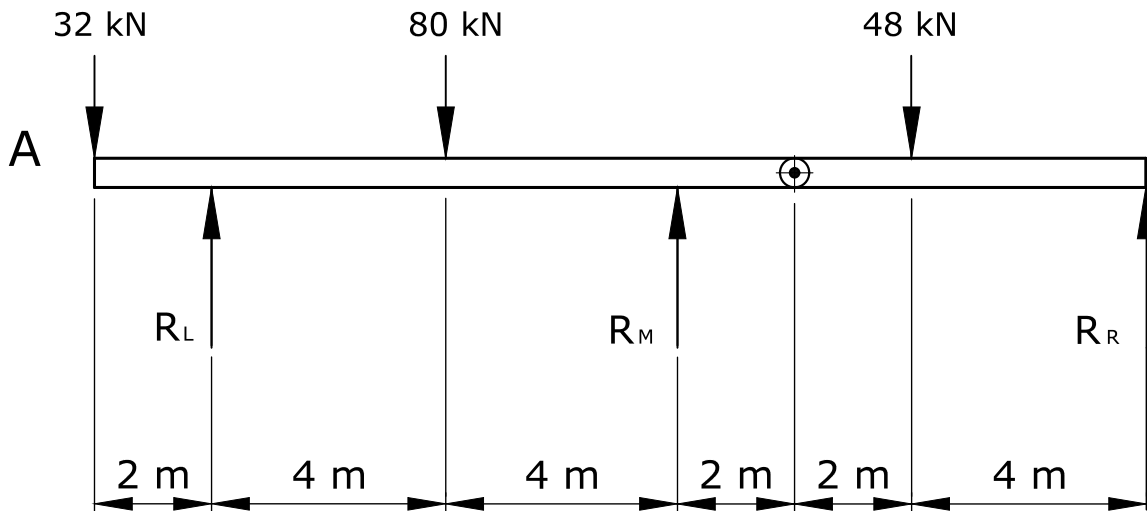

Figure 5

**Question 6.**

The traces VTH of an oblique plane are given in Figure 6c. Point O, shown in the plan, is the centre of the base of a cylinder  $\text{Ø}80 \text{ mm}$  and  $40 \text{ mm}$  high. The cylinder is resting on the oblique plane as shown in Figure 6b.

A hexagonal pyramid,  $80 \text{ mm}$  across the corners and having a perpendicular height of  $40 \text{ mm}$  is mounted on the cylinder as shown in Figure 6a. The orientation of the pyramid is such that, in the front elevation, the flat side of the pyramid base is parallel to the horizontal plane.

You are requested to:

- a. copy full size Figure 6c; (2)
- b. convert the oblique plane to an inclined plane by projecting an auxiliary elevation; (2)
- c. state the inclination of the oblique plane to the horizontal plane; (1)
- d. project point O onto the inclined plane and construct the combined cylindrical and pyramidal solid; (5)
- e. draw the plan view of the combined solid; (5)
- f. project the front elevation. (5)

Note: Show hidden details.

**(Total: 20 marks)**

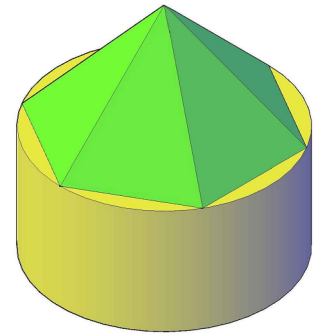

Figure 6a

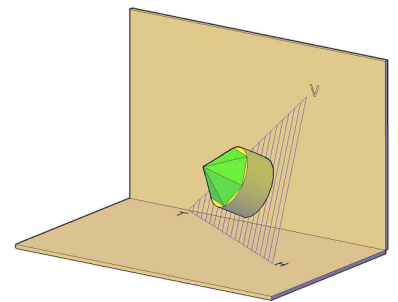

Figure 6b

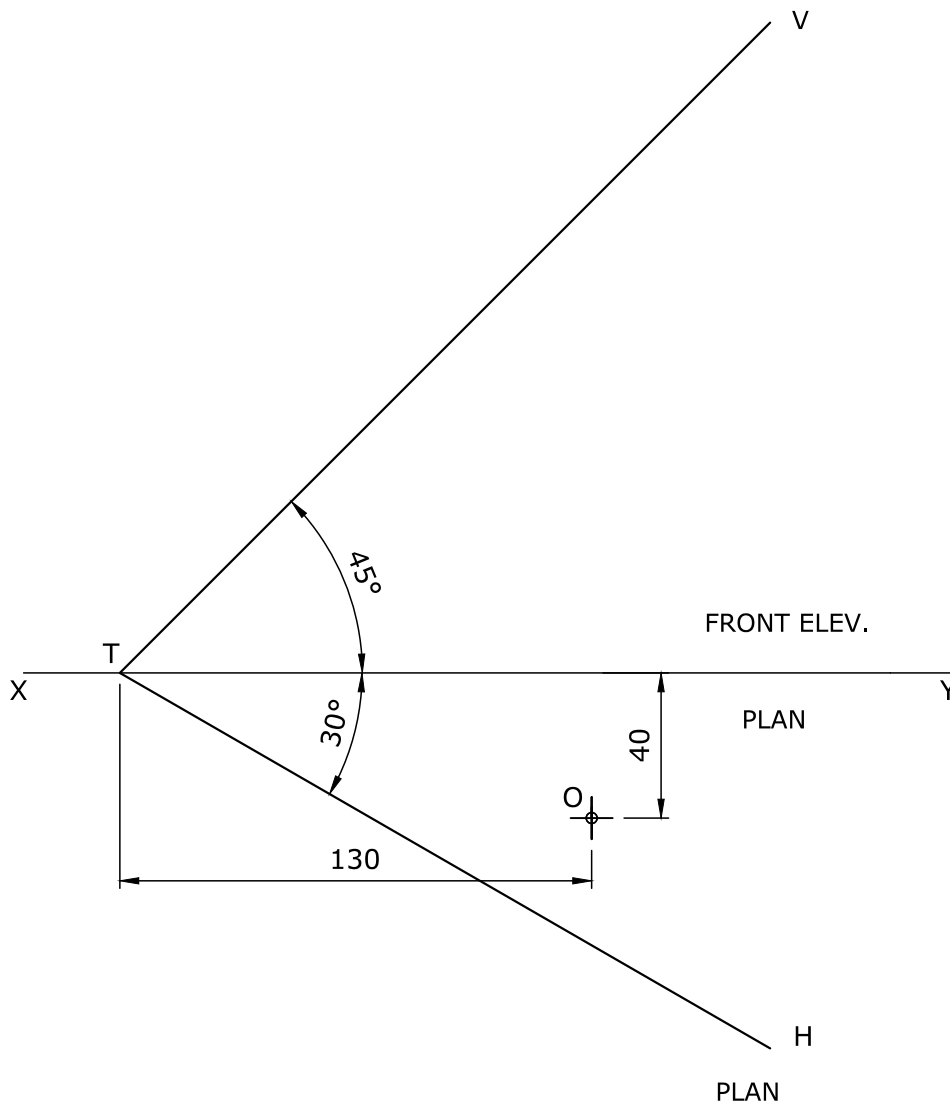
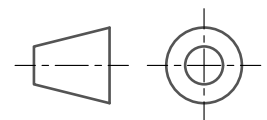

Figure 6c





---

SUBJECT:	<b>Engineering Drawing</b>
PAPER NUMBER:	II
DATE:	8 <sup>th</sup> June 2023
TIME:	4:00 p.m. to 7:05 p.m.

---

### **Directions to Candidates**

Write your index number where indicated at the top of all drawing sheets.

Attempt **Question 1** and any other **TWO** questions.

Programmable calculators **cannot** be used.

Unless otherwise stated:

- drawings should conform to B.S. or equivalent (ISO) standards;
- all dimensions are in millimetres;
- all answers are to be accurately drawn with instruments;
- all construction lines must be left on each solution;
- drawing aids may be used.

Dimensions not given should be estimated using engineering judgement.

Careful layout and presentation are important.

Marks will be awarded for accuracy, clarity and appropriateness of constructions.

Mark allocations are shown in brackets.

Question 1 carries 60 marks. Questions 2, 3 and 4 carry 20 marks.



**Question 1.**

Figure 1b shows an exploded view of a lever operated control valve. Details of the component parts are given on the A3 sheets (Figures 1c and 1d). The valve is to be assembled in the following sequence:

- The valve spindle (item 2) fits into the valve body (item 1).
- The valve seat (item 3) is screwed into the valve body resting on the Ø56 hole of the valve body.
- The gland (item 4) is screwed into the valve seat leaving a space of 15 mm between face A on the valve seat and face B under the gland nut.
- The fulcrum nut (item 5) is screwed into the M108 threaded portion of the valve body. Face C on the fulcrum nut is to rest on face D on the valve body.
- The operating lever (item 6) is inserted into the 12 mm wide slot of the valve spindle and secured to the forked top of the fulcrum nut by means of the fulcrum pin (item 7).
- A washer (item 8) is inserted in the fulcrum pin and secured by means of a split pin (item 9) which is not shown in the illustration and in the detail drawings.

Draw, full size, the following views of the assembled valve:

- a) a sectional front elevation on cutting plane X - X; (48)
- b) an end elevation as seen from the left-hand side. (12)

Notes:

- Do not show hidden details.
- Draw the valve spindle with the valve chamfered face in contact with the valve seat face (closed position).
- Start your drawing 20 mm above the title block (see Figure 1a).

**(Total: 60 marks)**

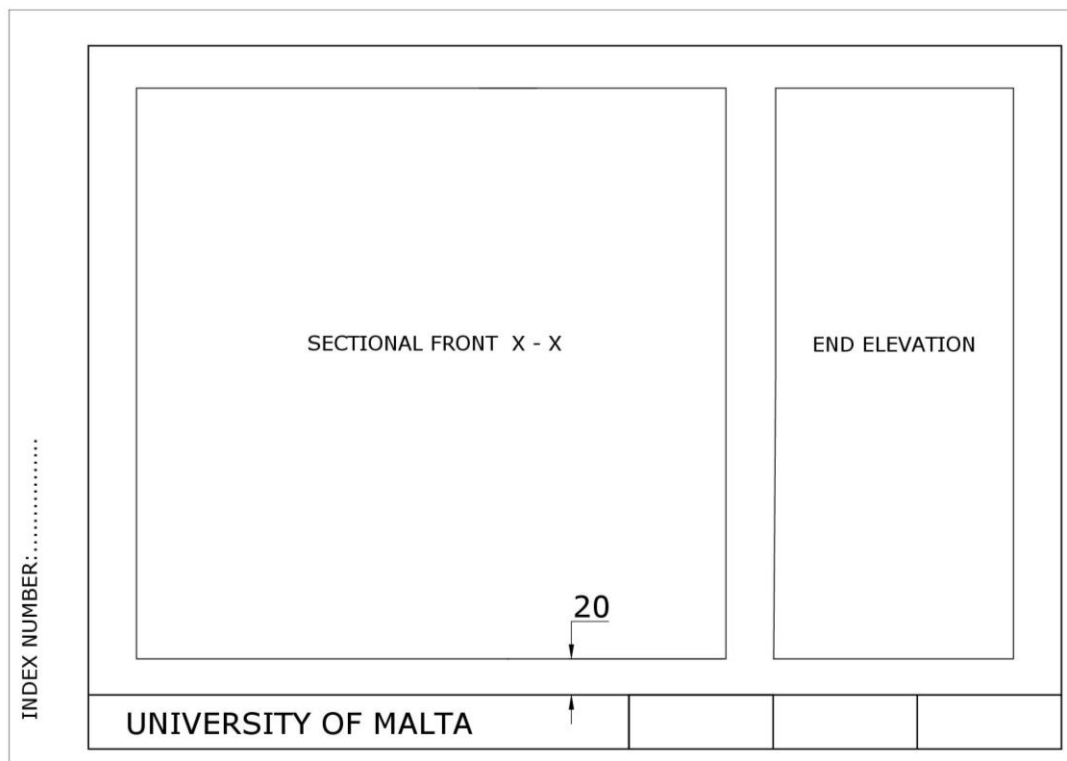

Figure 1a

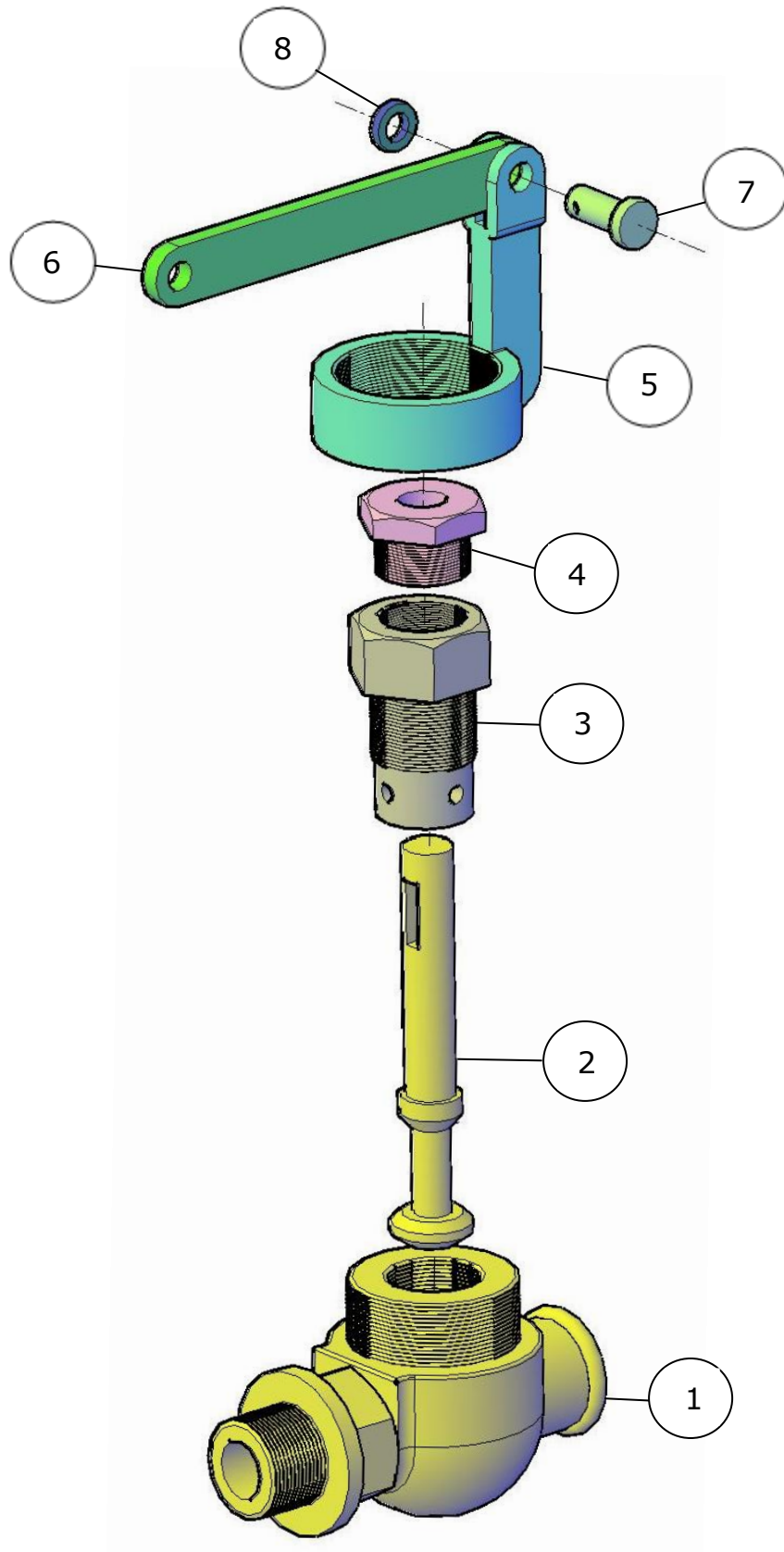

Figure 1b

***Please turn the page.***

**Question 2.**

A key is a piece of machined metal which is used to temporarily connect a shaft and a hub, thus preventing relative motion between them. In the case of sunk keys, a keyway and a key slot are machined in the hub and the shaft respectively creating the room to accommodate the appropriate key. Particular situations call for specific key types. Some of the more common types of keys are:

- square key;
- gib-head key;
- feather key;
- woodruff key.

Figure 2 shows two orthographic views of a shaft and a hub. Draw full size:

- a) an isometric view of a gib-head key that would fit the given shaft and hub; (3)
- b) an isometric view of an appropriate feather key with countersunk holes at both ends; (4)
- c) an isometric exploded view of the shaft, the hub and a square key, showing clearly the sequence of assembly; (8)
- d) a sectional view along the axis of the shaft and hub showing an assembled shaft, hub, and Woodruff key (show the area around the key in local section). (5)

**(Total: 20 marks)**

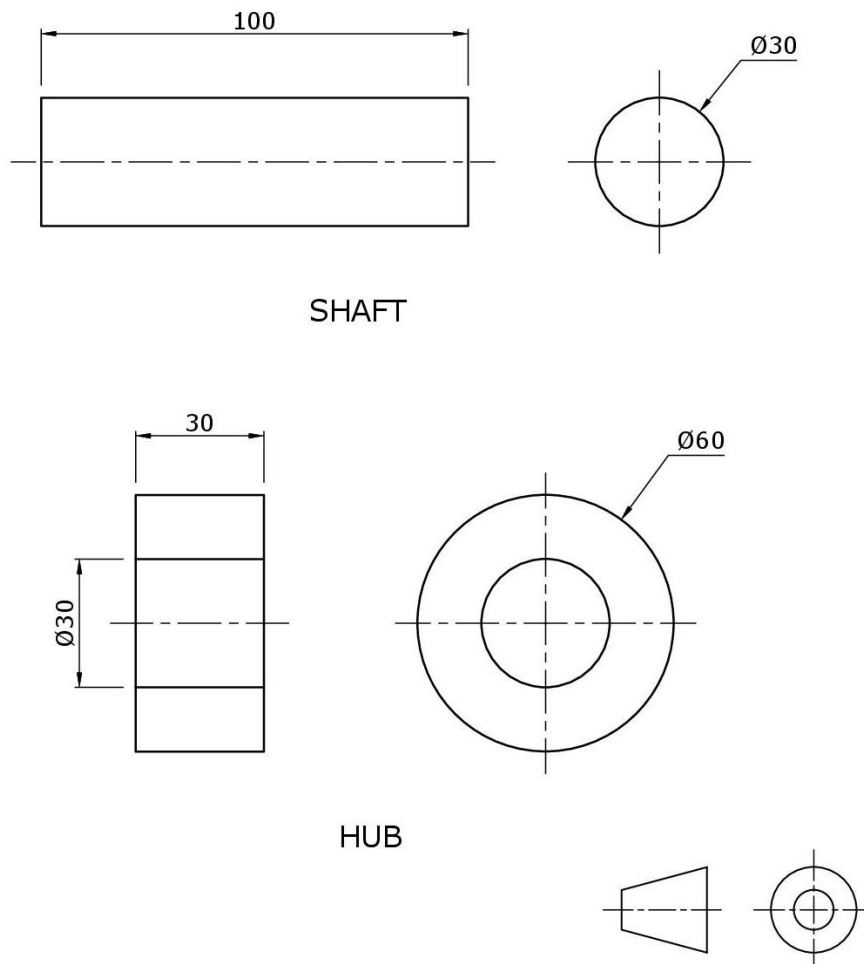

Figure 2

**Question 3.**

Positive locking devices are used in conjunction with fasteners to prevent or reduce the possibility of working loose from vibration. Figures 3a and 3b show two orthographic views of a tab washer and a locking plate respectively.

You are requested to:

- a) draw, approximately full size, a well-proportioned freehand isometric sketch to illustrate how the tab washer is used to lock the movement of the assembled nut; (8)
- b) draw, approximately full size, a well-proportioned freehand isometric sketch to illustrate how the locking plate is used to lock the movement of the assembled nut; (8)
- c) add motion arrows and annotations to enhance your illustrations. (4)

**(Total: 20 marks)**

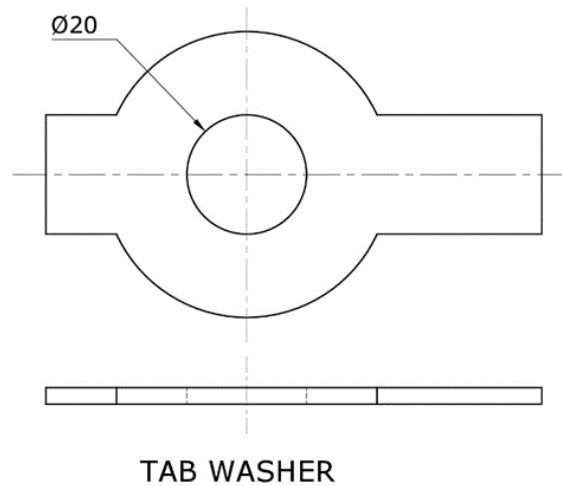

Figure 3a

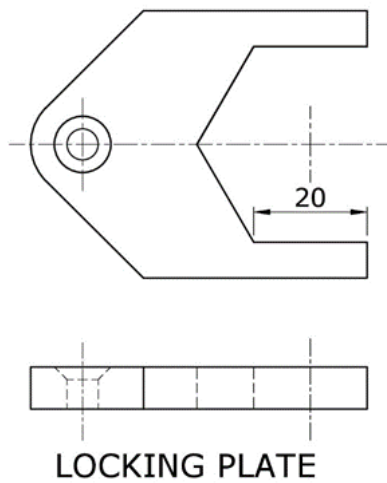

Figure 3b

***Please turn the page.***

**Question 4.**

The quality of any finished surface has a direct connection with the function and wear of the component. Machined surface finishes vary considerably in quality, and the maximum roughness acceptable is quoted on the machined surface.

- a) Draw and label the **THREE** surface texture symbols used to indicate the following:
- i. any manufacturing process is permitted; (1)
  - ii. material removal is required; (1)
  - iii. material removal is not permitted. (1)
- b) Draw, Figure 4a(i), 4a(ii) and 4a(iii), to a suitable size.
- i. In the drawings 4a(i) and 4a(ii), indicated by the arrow on the surface; show the direction of lay, in association with the machining symbol of the process of your choice. Also show the direction of lay or pattern on the given plan. (3)
  - ii. In the drawing 4a(iii), indicated by the arrow on the surface; show that the surface is to be grinded to a value of surface roughness of (0.2). Include the representation of the specific process or production method. Also show the direction of lay on the given plan. (2)

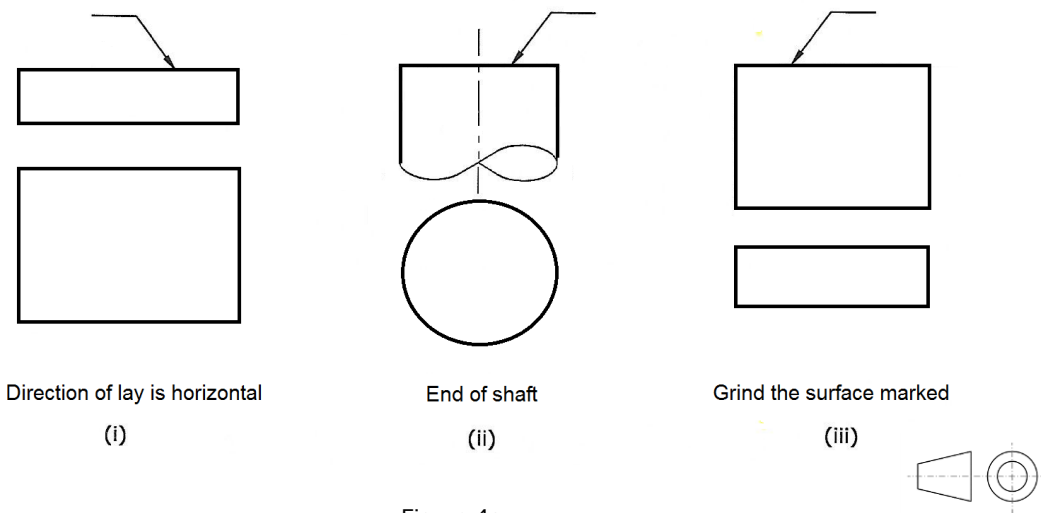

Figure 4a

c) Figure 4b shows a sectional view of a cast iron bearing block.

- A substantial amount of the surface texture of the bearing block is to remain in its original state (cast iron finish).
- The bearing hole is to be bored.
- The area around the retaining bolts is to be spot faced.
- The retaining bolts holes are to be drilled.
- The base is to be milled.

You are requested to:

- i. Copy the given drawing to a suitable scale. (2)
- ii. Convert the annotations into surface texture symbols. (5)
- iii. Use the table given in Figure 4c to suggest the value of surface roughness for each instance. (5)

Note:

The spot facing operation is to be carried out by means of an end mill.

**(Total: 20 marks)**

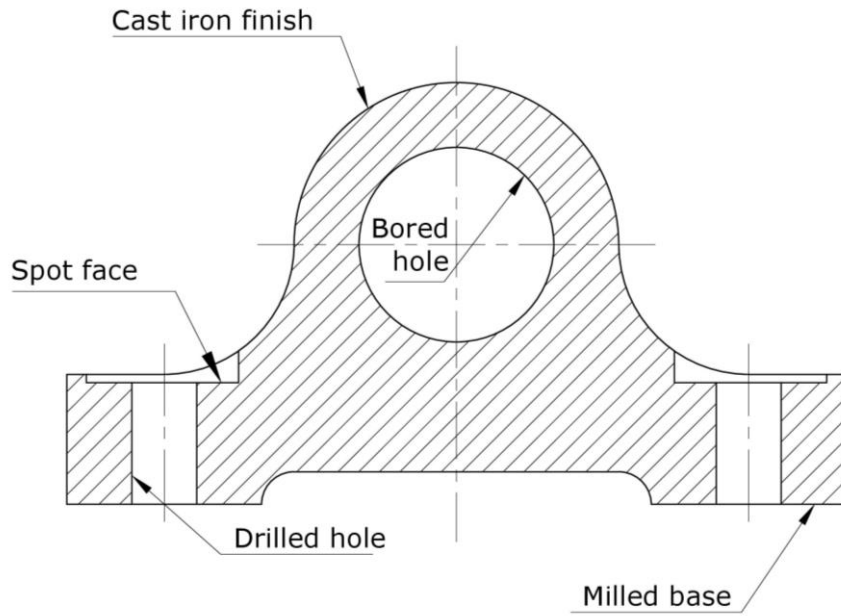
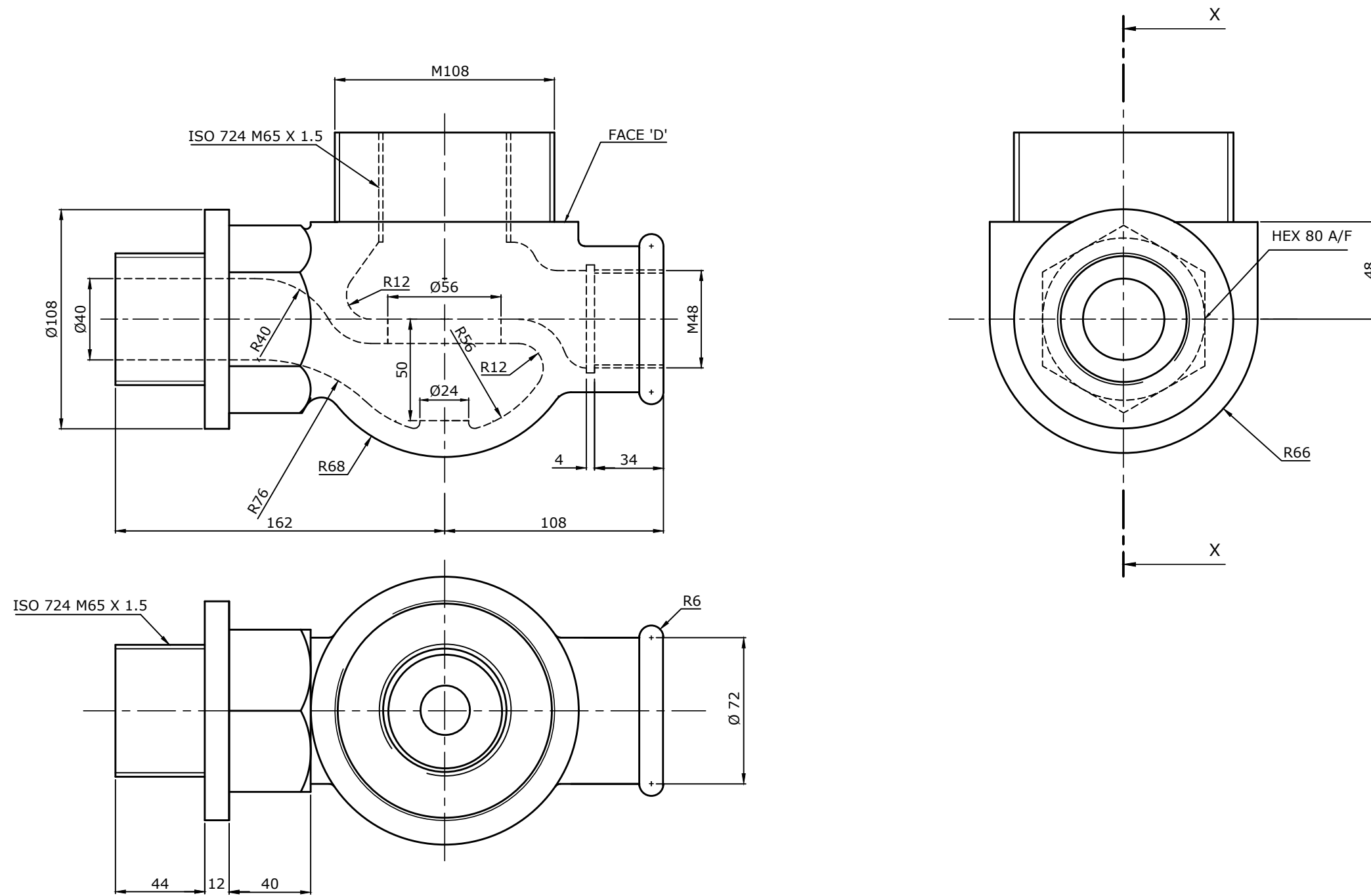

Figure 4b

Sand-Casting	Drilling	Boring	Milling	Lapping	Honing	Micrometers
						0.025
						0.05
						0.1
						0.2
						0.4
						0.8
						1.6
						3.2
						6.3
						12.5
						25
						50

Approximate Ra surface roughness ranges obtainable by some common production methods.

Figure 4c



VALVE BODY (Item 1)

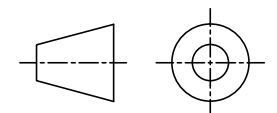

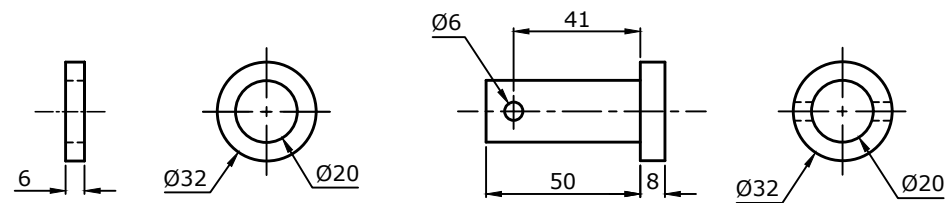

WASHER (Item 8)

FULCRUM PIN (Item 7)

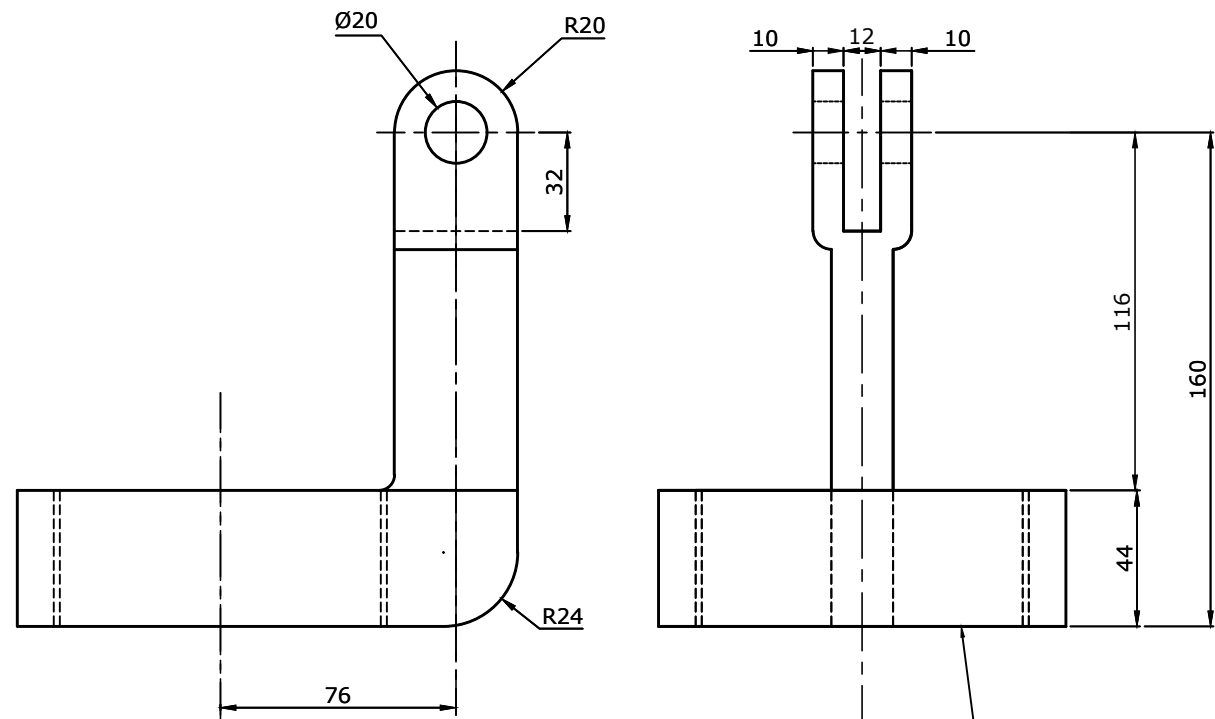

FULCRUM NUT (Item 5)

VALVE SEAT (Item 3)

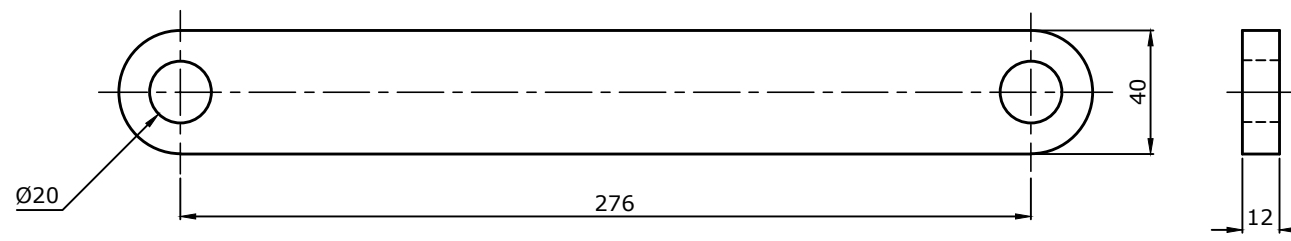

OPERATING LEVER (Item 6)

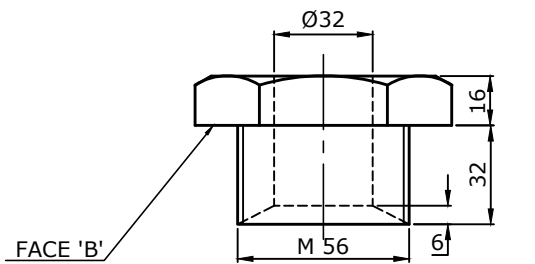

GLAND (Item 4)

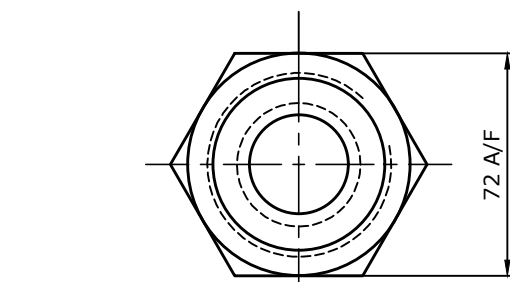

FACE 'A'

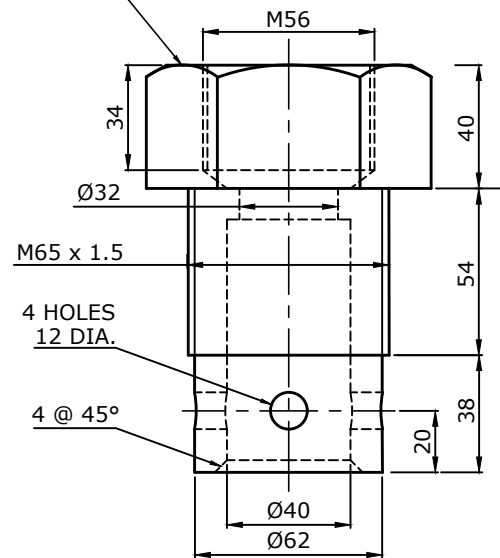

M65 x 1.5

4 HOLES 12 DIA.

4 @ 45°

$\varnothing 40$

$\varnothing 62$

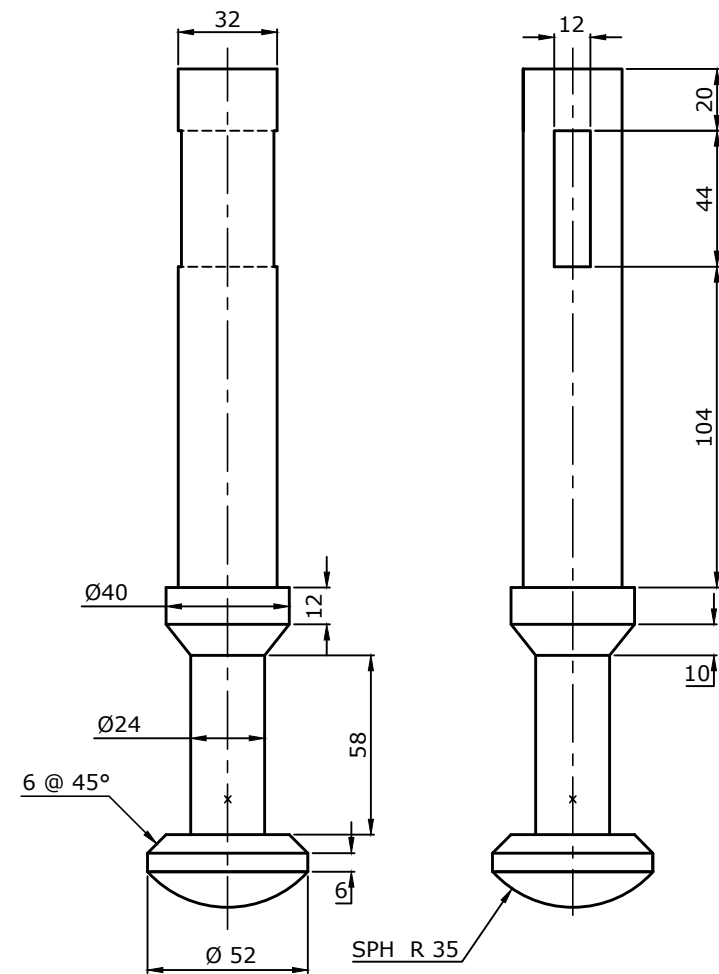
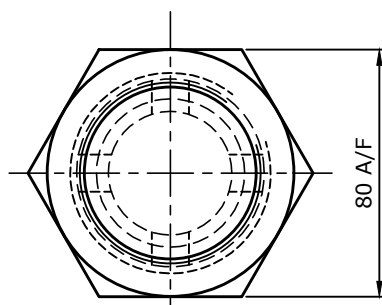

VALVE SPINDLE (Item 2)

