



Subject:	Engineering Drawing/Graphical Communication
PAPER NUMBER:	I
DATE:	30 th August 2023
TIME:	9:00 a.m. to 12:05 p.m.

Directions to Candidates

Write your index number where indicated at the top of all drawing sheets.

Attempt any **FIVE** questions.

Programmable calculators cannot be used.

Unless otherwise stated:

- a. drawings should conform to B.S or equivalent (ISO) standards;
- b. all dimensions are in millimetres;
- c. all answers are to be accurately drawn with instruments;
- d. all construction lines must be left in each solution;
- e. drawing aids may be used.

Dimensions not given should be estimated.

Careful layout and presentation are important.

Marks will be awarded for accuracy, clarity and appropriateness of constructions.

Question 1.

The illustration in Figure 1a shows a solid piece of cylindrical clay placed eccentrically on a pottery wheel. The wheel is rotated and a cutting tool shaves the excess clay until a smaller diameter cylinder, eccentric with the original larger diameter cylinder, is formed at the top.

A plan and an incomplete front elevation of the eccentric cylinders are shown in Figure 1b.

You are requested to:

- a. copy the given views; (2)
- b. complete the front elevation showing clearly the curve of intersection between the eccentric cylinders; (10)
- c. project an end elevation as seen from the direction of arrow X; (6)
- d. show hidden details. (2)

(Total: 20 marks)

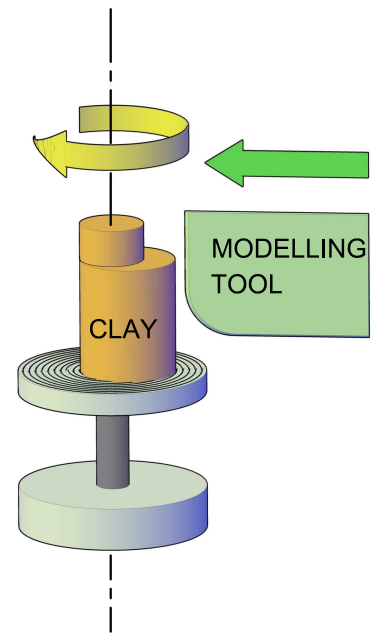

Figure 1a

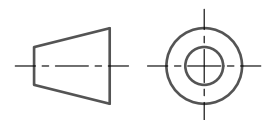
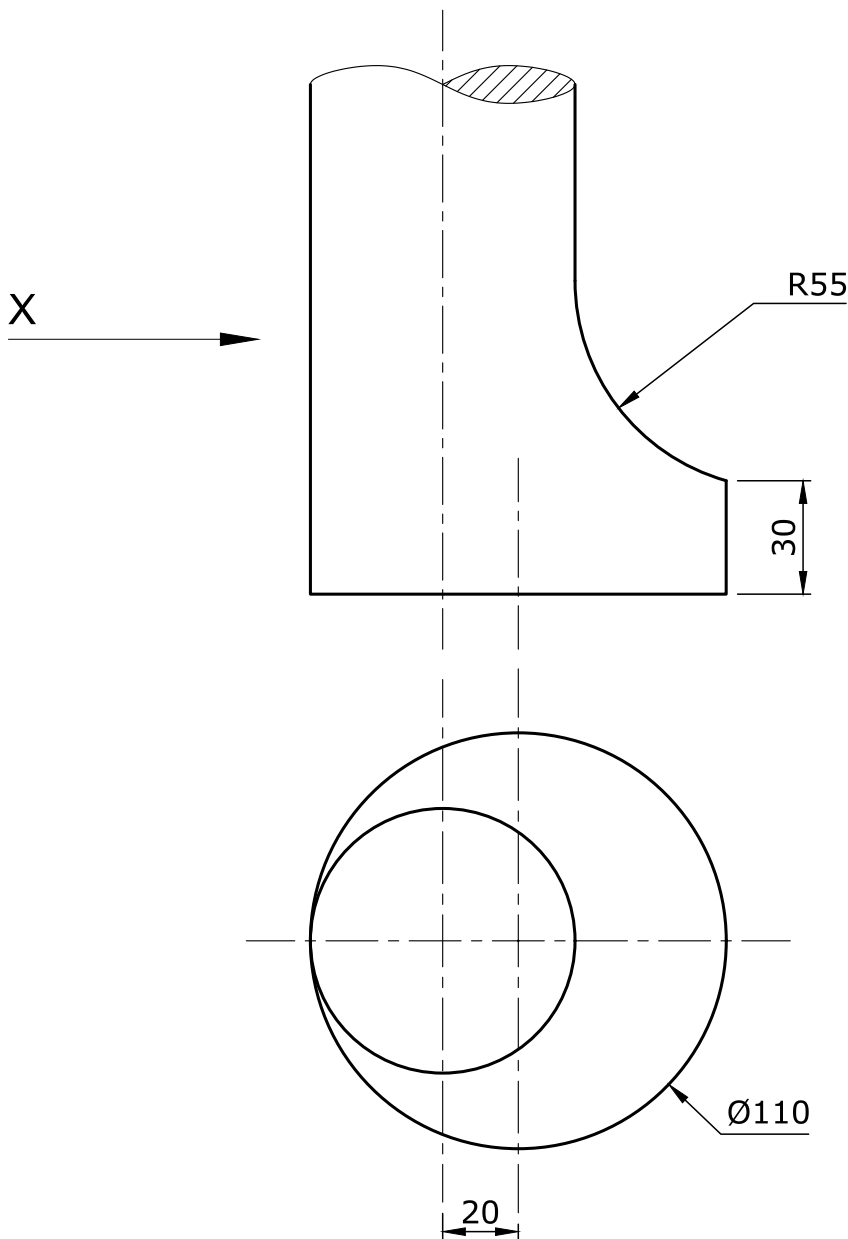

Figure 1b

Question 2.

Figure 2a shows a model of a podium. Orthographic views of the podium are given in Figure 2b.

You are requested to:

- a. construct an isometric scale; (1)
- b. use the isometric scale measurements to copy the given views; (4)
- c. produce an isometric projection of the podium by using the isometric scale. (15)

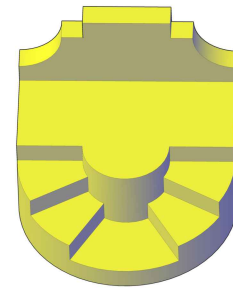

Note:
Place corner X of the isometric crate in the lowermost position.

(Total: 20 marks)

Figure 2a

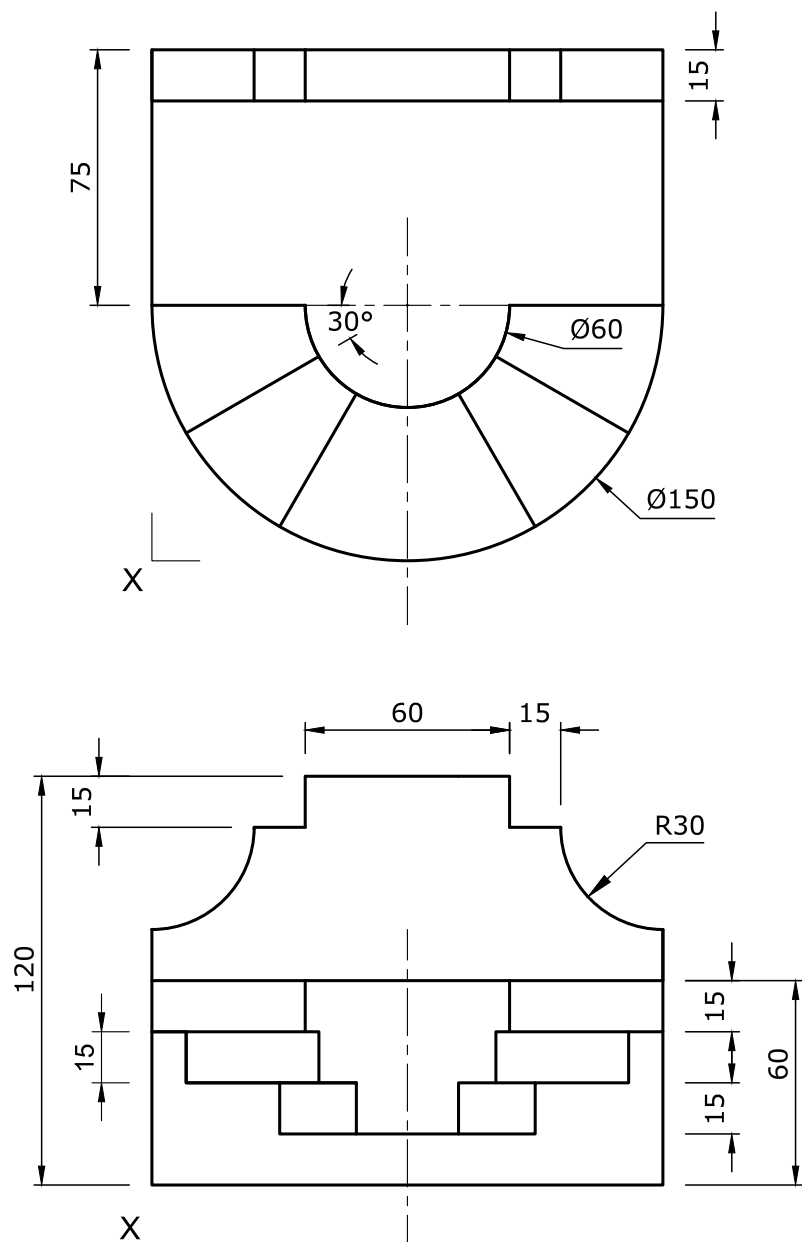
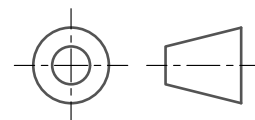

Figure 2b



Question 3.

An illustration of a ring holder cut by an oblique plane is given in Figure 3a. Two orthographic views and the traces of the oblique plane (VT, HT) cutting the ring holder are given in Figure 3b.

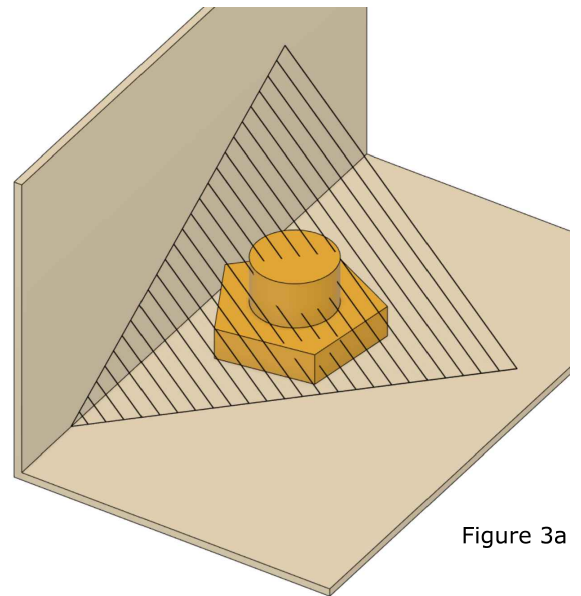

Figure 3a

You are requested to:

- a. copy the given views; (3)
- b. project an auxiliary elevation of the ring holder, showing the oblique plane as an inclined cutting plane; (5)
- c. project the cutting plane on plan and front elevation; (4)
- d. project a second auxiliary plan, showing the ring holder and the true shape of cut, from the first auxiliary elevation. (8)

(Total: 20 marks)

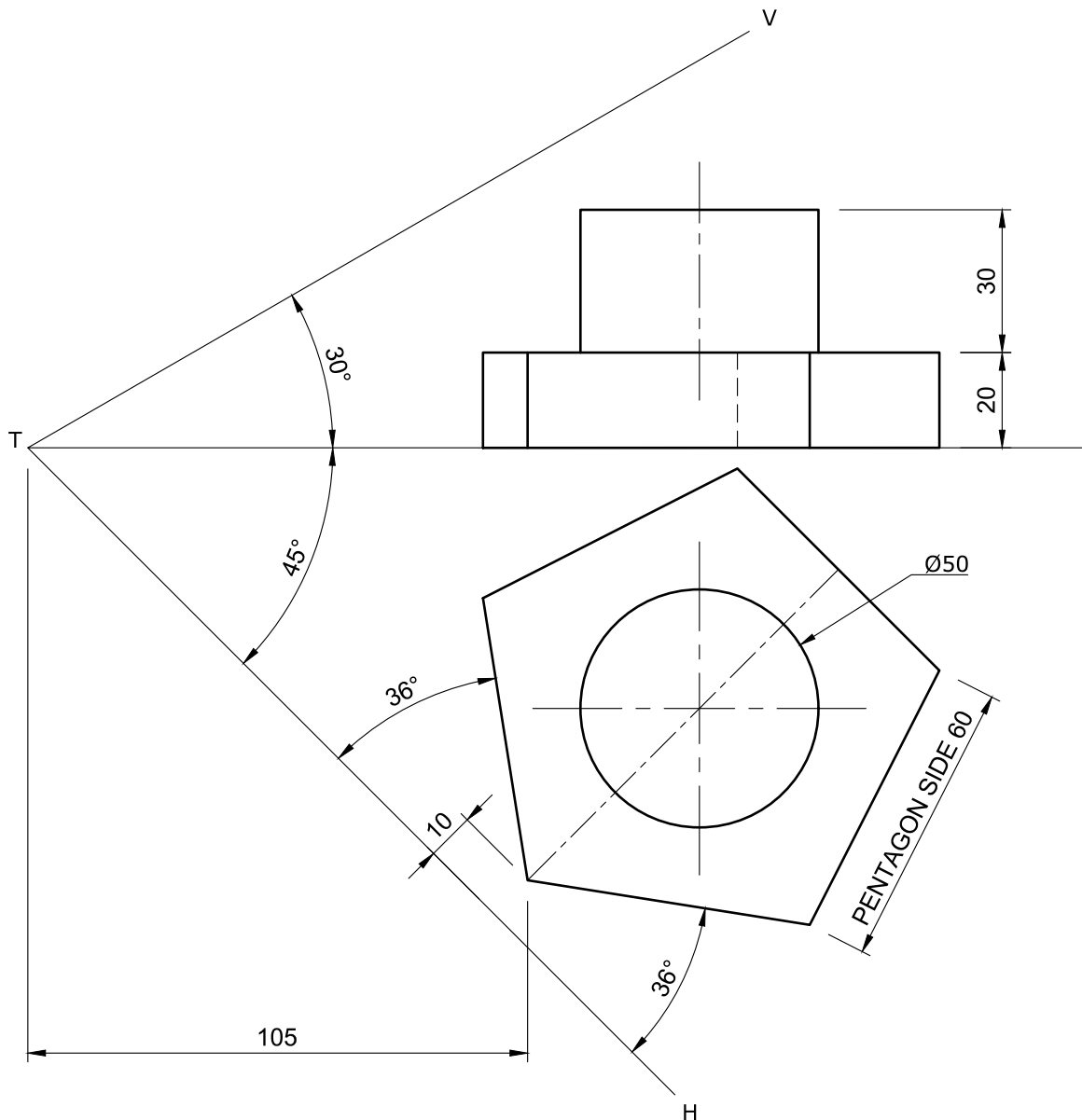
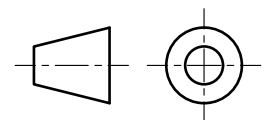

Figure 3b



Question 4.

Figure 4 below shows two orthographic views of a transition piece between a truncated square prism and an octagonal prism.

You are requested to:

- a. copy the given views; (3)
- b. construct the necessary true lengths; (7)
- c. construct the full surface development of the transition piece. (10)

Note:

Place the seam line along edge PQ.

(Total: 20 marks)

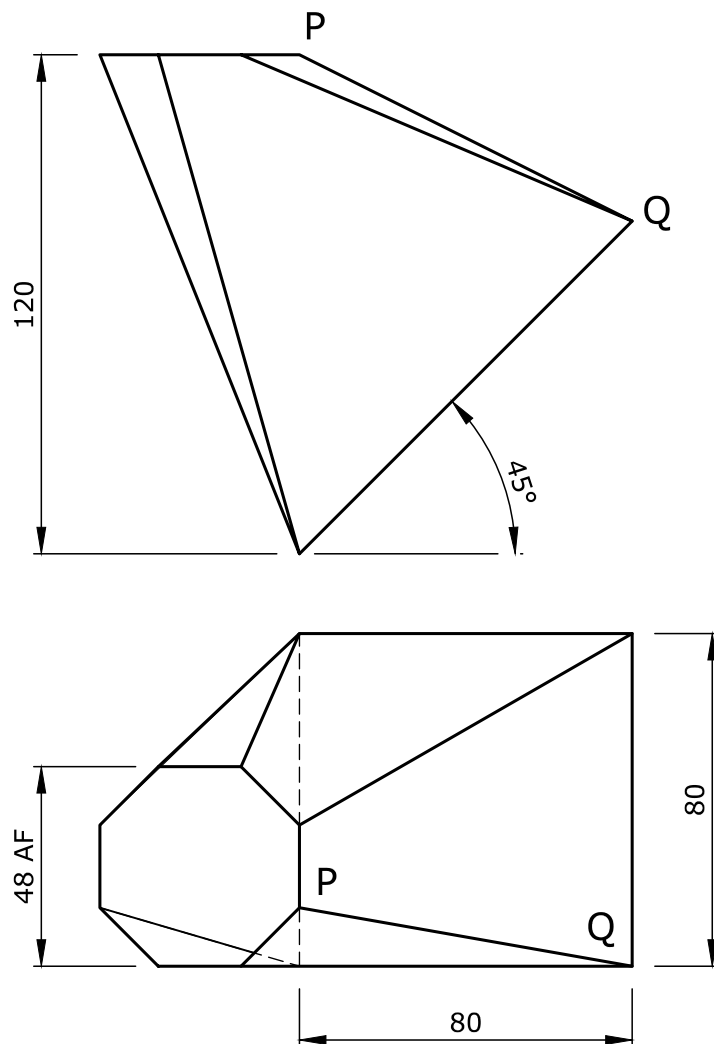
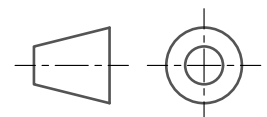

Figure 4



Question 5.

A laboratory arrangement of a plate cam operating a rocker arm mechanism is shown in Figure 5a.

A close-up view of the rocker arm is shown in Figure 5b.

A line drawing of the top start position of the cam mechanism is given in Figure 5c.

Rocker arm AOB is pivoted at O and has two rollers fitted at both ends. Roller 'A' follows the cam profile and roller 'B' moves the sliding rod a maximum distance of 41 mm to the left.

The cam causes the roller 'A' to swing downwards and upwards according to the following data:

- 0° - 180° fall to the minimum position with uniform acceleration and retardation;
- 180° - 240° lower dwell;
- 240° - 360° rise to the start position with simple harmonic motion.

You are requested to:

- a. construct a line drawing of Figure 5c; (3)
- b. locate the minimum position of roller follower 'A' when roller 'B' moves the sliding rod the distance of 41 mm to the left; (2)
- c. determine and state the minimum cam radius; (2)
- d. draw the cam displacement diagram; (6)
- e. construct the cam profile. (7)

Note: The cam is to rotate anti-clockwise.

(Total 20 marks)

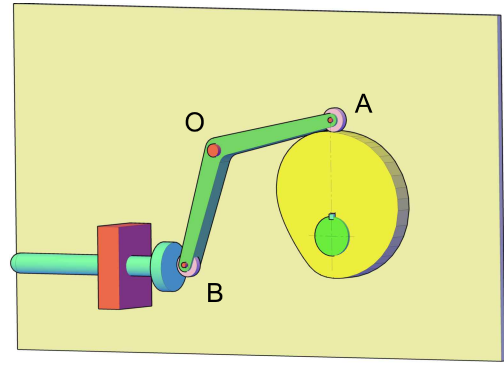

Figure 5a

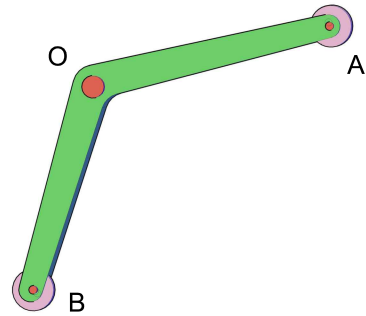

Figure 5b

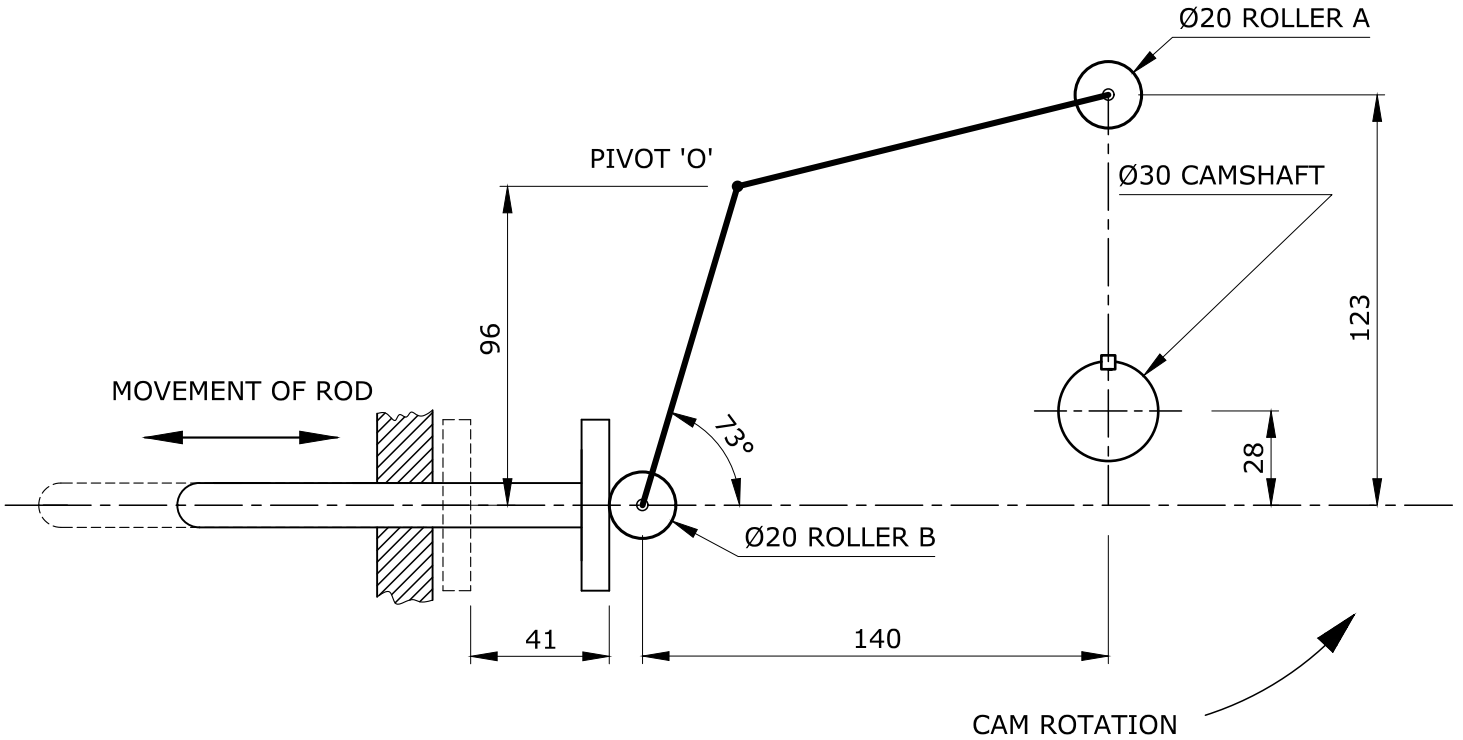

Figure 5c

Question 6.

A drawing of a roof truss, resting on two simple supports, is shown in Figure 6. Four members of the truss have been labeled m, n, o, and p.

You are requested to:

- a. copy Figure 6 by using the indicated scale; (2)
- b. label the spaces by applying Bow's notation; (1)
- c. evaluate graphically the reactions R_L and R_R (use a load line scale of 10 mm rep 1 kN); (6)
- d. find the forces acting in members m, n, o, and p, distinguishing between struts and ties; (9)
- e. tabulate your answers. (2)

(Total: 20 marks)

Space diagram scale: 10 mm rep 1 m

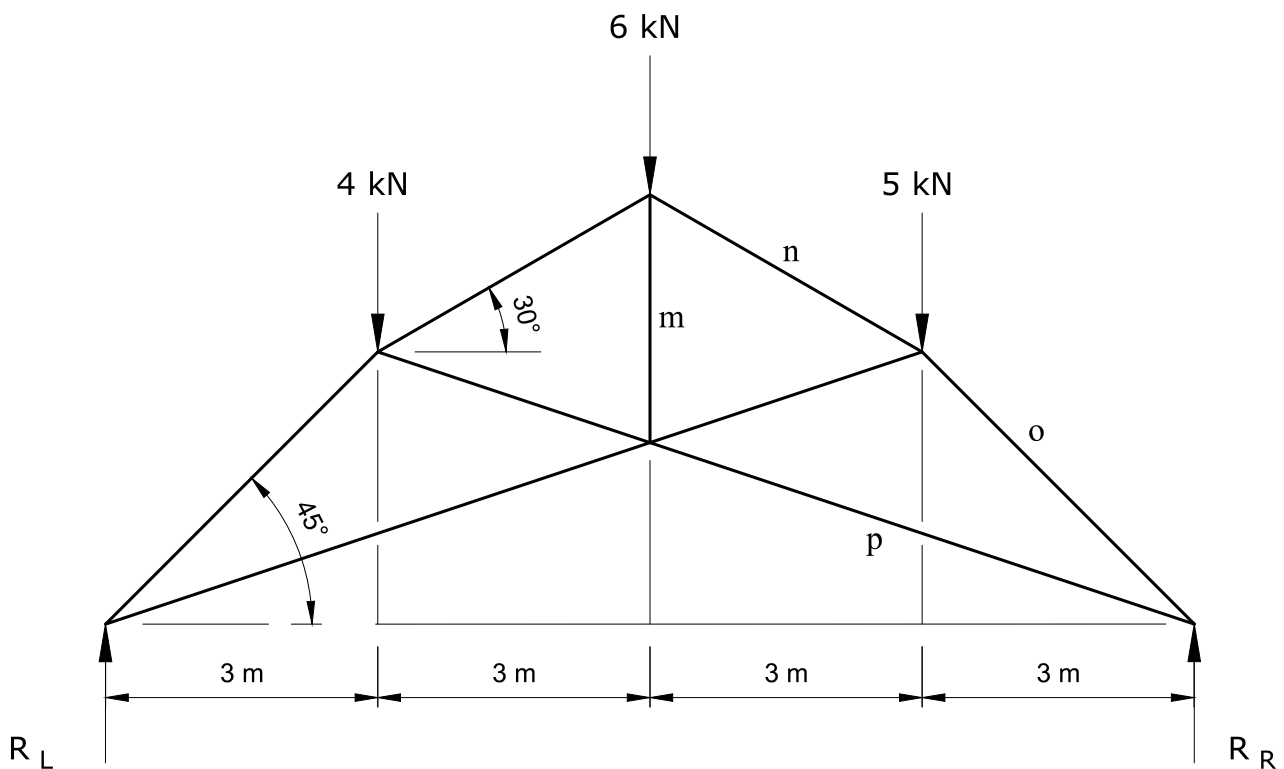

Figure 6



SUBJECT:	Graphical Communication
PAPER NUMBER:	II
DATE:	31 st August 2023
TIME:	9:00 a.m. to 12:05 p.m.

Directions to Candidates

Write your index number where indicated at the top of all drawing sheets.

Attempt **all** questions.

Programmable calculators **cannot** be used.

Unless otherwise stated:

- drawings should conform to B.S. or equivalent (ISO) standards;
- all dimensions are in millimetres;
- answers are to be accurately drawn with instruments;
- all construction lines must be left on each solution;
- drawing aids may be used.

Dimensions not given should be estimated.

Careful layout and presentation are important.

Marks will be awarded for accuracy, clarity and appropriateness of constructions.

Colour/shading should be used where appropriate.

Mark allocations are shown in brackets.

Question 1 carries 34 marks. Questions 2, 3, and 4 carry 22 marks **each**.

Question 1.

Figure 1 shows three orthographic views of a sitting room. These orthographic views show the proportion of every element within the entire space. Use this information to draw a one-point estimated perspective of the sitting room. The arrows on the front indicate the viewing direction.

- a) Using **THREE** preliminary sketches, explore alternative positions of the horizon line and identify the one which, in your opinion, best describes the spaciousness of the entire area. (3)
- b) Based on the choice made in part (a), use a suitable scale to produce the required illustration on a single side of an A2 size paper, making the best use of the space available. (26)
- c) Enhance your drawing by colouring small areas of the different items appearing in your illustration. (5)

Notes:

- The fireplace is made of limestone.
- The sofa is made of red leather.
- The TV and coffee tables are made of timber.
- The tiles are made of marble looking ceramic.
- The height of the courses and the size of the square tiles are equal.

(Total: 34 marks)

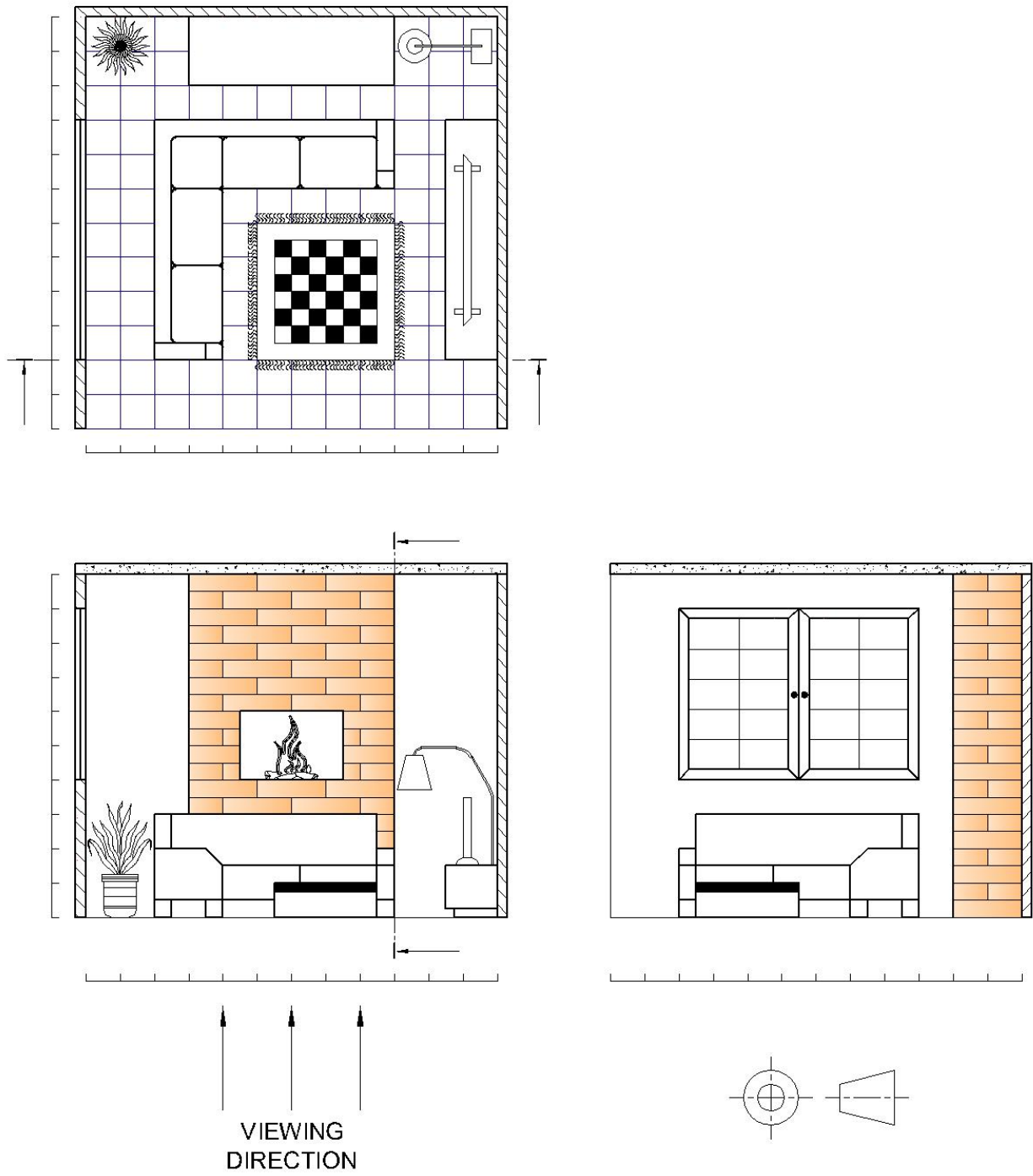

Figure 1

Please turn the page.

Question 2.

Figure 2 shows a billboard used for advertisement.

A youth club wants to organise a summer beach party and needs an attractive and relevant poster with which to advertise the event.

Produce this poster, which needs to include both an eye-catching title; 'SUMMER BEACH PARTY', and suitable related graphics.

You need to present your work broken down according to the following steps and as shown in Figure 2b below.

a) Written analysis

Identify, using keywords/short phrases the main parameters of the design brief. (2)

b) Graphical analysis

Based on your response to the written analysis, produce a series of preparatory sketches that illustrate your developing ideas. (4)

c) Design synthesis

Clearly identify those elements present in your sketches that you intend to use in your final design. (2)

d) Final realisation

Use colour and shading to produce your final realisation in a rectangle as shown in Figure 2b. (14)

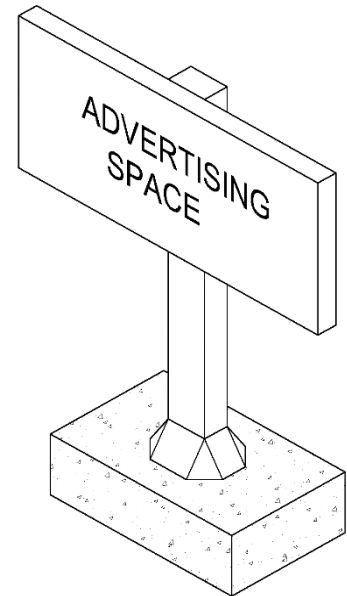

Figure 2a

Notes:

- Use suitable typefaces for your design.
- Details of the page layout and the design space are given in Figure 2b below.

(Total: 22 marks)

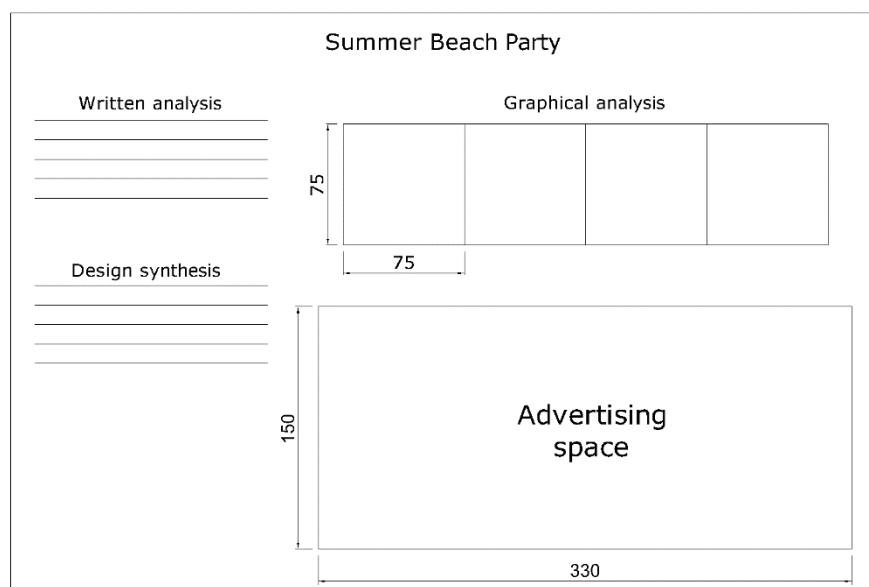

Figure 2b

Question 3.

Figure 3 shows four orthographic views of a swivelling mirror with stand.

You are requested to:

- a) make a well-proportioned pictorial (3D) freehand drawing of this swivelling mirror with stand.(14)
- b) colour and shade your drawing to communicate the following features: (8)
 - round mirror face - glass
 - round mirror frame – yellow durable plastic
 - u-shaped mirror holder – red anodised aluminium
 - base – red anodised aluminium
 - helical vertical stand – yellow anodised aluminium
 - internal vertical rod – white durable plastic

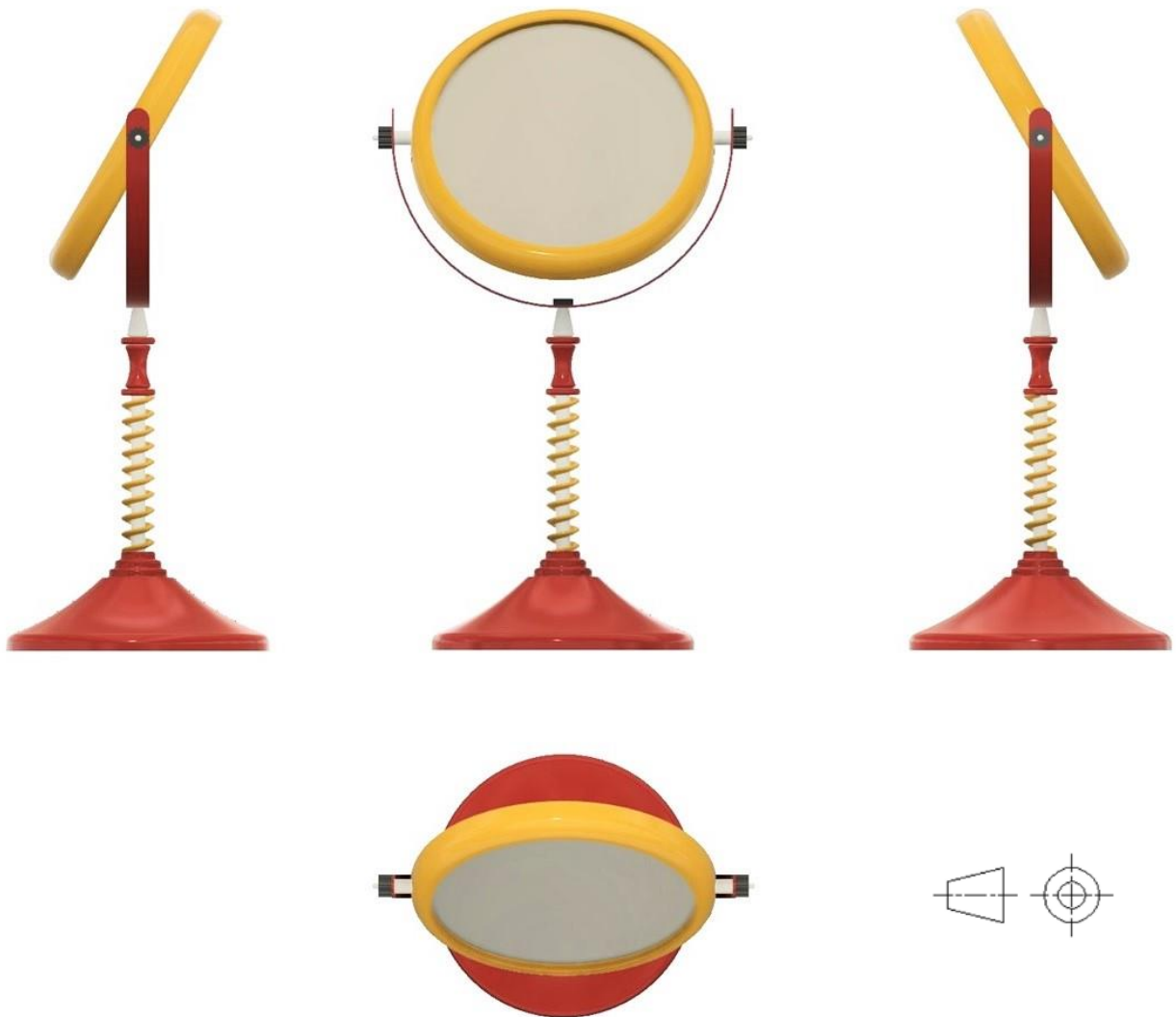

Figure 3

(Total: 22 marks)

Please turn the page.

Question 4.

Figure 4 shows a three-dimensional line sketch of a webcam. This webcam has a spherical head that can swivel on its vertical axis and is attached to a stand that can be clipped to a horizontal surface.

You are requested to:

- a) draw a two-dimensional front freehand sketch of this webcam as seen when looking from the direction of arrow F; (12)
- b) render your sketch to show the volume of the webcam. (10)

Notes:

- The lens is made of glass.
- The entire body of the webcam is made of durable plastic (the colour is left to your discretion).

(Total: 22 marks)

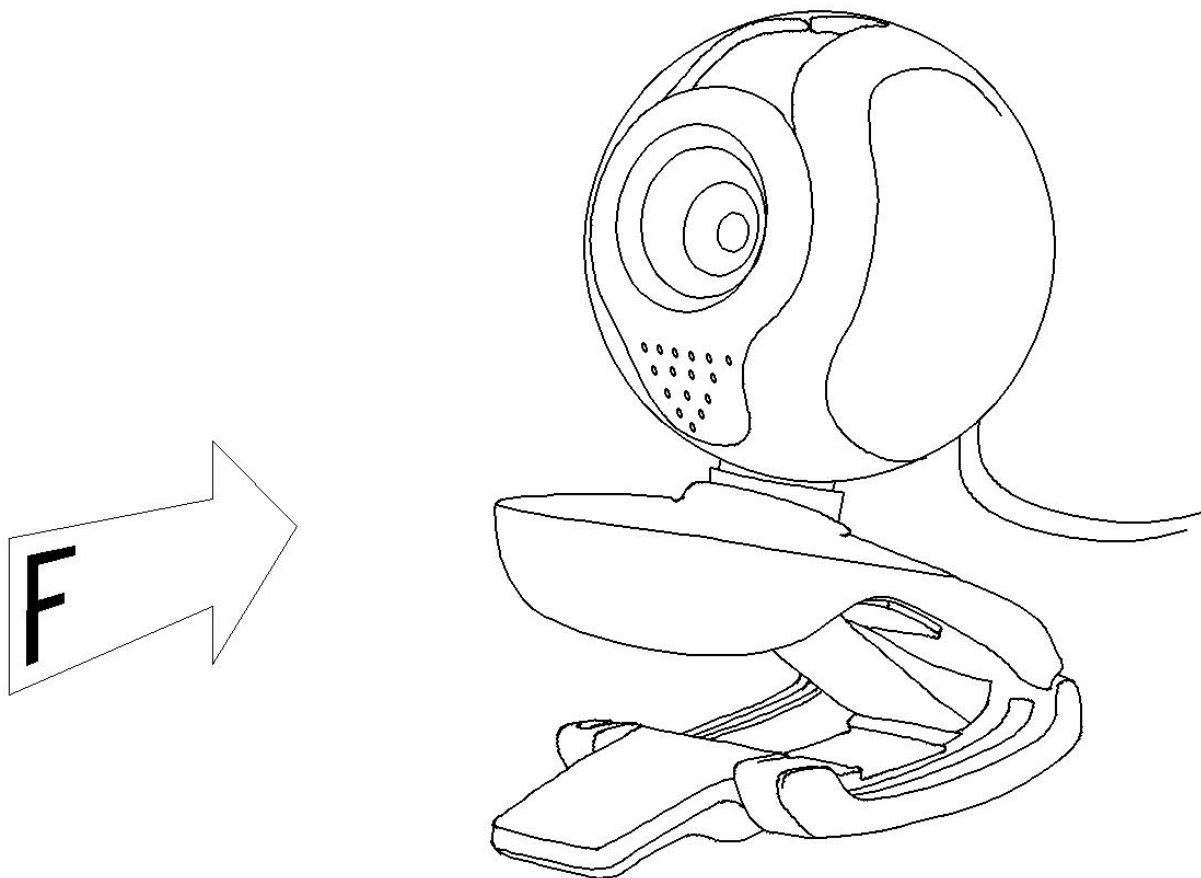

Figure 4

SUBJECT:	Engineering Drawing
PAPER NUMBER:	II
DATE:	31 st August 2023
TIME:	9:00 a.m. to 12:05 p.m.

Directions to Candidates

Write your index number where indicated at the top of all drawing sheets.

Attempt **Question 1** and any other **TWO** questions.

Programmable calculators **cannot** be used.

Unless otherwise stated:

- drawings should conform to B.S. or equivalent (ISO) standards;
- all dimensions are in millimetres;
- all answers are to be accurately drawn with instruments;
- all construction lines must be left on each solution;
- drawing aids may be used.

Dimensions not given should be estimated using engineering judgement.

Careful layout and presentation are important.

Marks will be awarded for accuracy, clarity and appropriateness of constructions.

Mark allocations are shown in brackets.

Question 1 carries 60 marks. Questions 2, 3 and 4 carry 20 marks.

Question 1.

Figure 1b shows an exploded view of a lever operated control valve. Details of the component parts are given on the A3 sheets (Figures 1c and 1d). The valve is to be assembled in the following sequence:

- The valve spindle (item 2) fits into the valve body (item 1).
- The valve seat (item 3) is screwed into the valve body resting on the Ø56 hole of the valve body.
- The gland (item 4) is screwed into the valve seat leaving a space of 15 mm between face A on the valve seat and face B under the gland nut.
- The fulcrum nut (item 5) is screwed into the M108 threaded portion of the valve body. Face C on the fulcrum nut is to rest on face D on the valve body.
- The operating lever (item 6) is inserted into the 12 mm wide slot of the valve spindle and secured to the forked top of the fulcrum nut by means of the fulcrum pin (item 7).
- A washer (item 8) is inserted in the fulcrum pin and secured by means of a split pin (item 9) which is not shown in the illustration and in the detail drawings.

Draw, full size, the following views of the assembled valve:

- a) a sectional front elevation on cutting plane X - X; (48)
- b) an end elevation as seen from the left-hand side. (12)

Notes:

- Do not show hidden details.
- Draw the valve spindle with the valve chamfered face in contact with the valve seat face (closed position).
- Start your drawing 20 mm above the title block (see Figure 1a).

(Total: 60 marks)

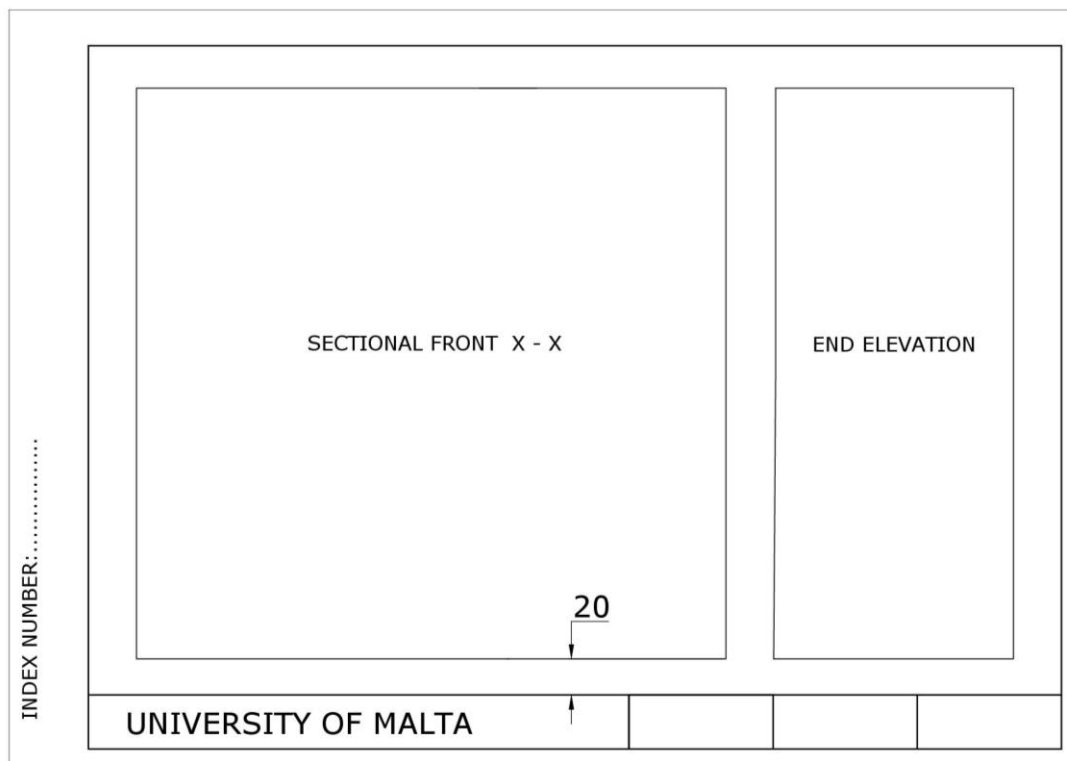

Figure 1a

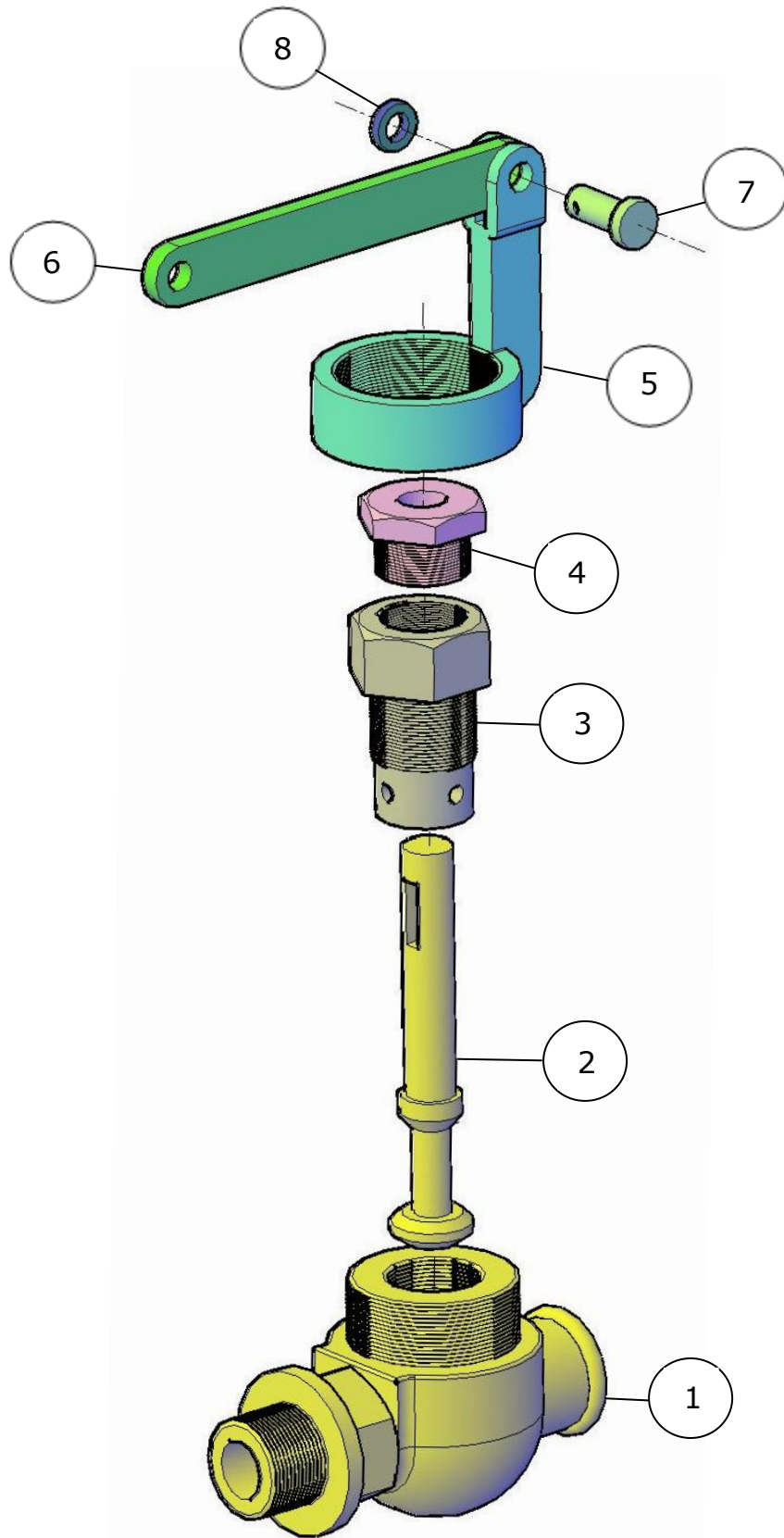

Figure 1b

Please turn the page.

Question 2.

A key is a piece of machined metal which is used to temporarily connect a shaft and a hub, thus preventing relative motion between them. In the case of sunk keys, a keyway and a key slot are machined in the hub and the shaft respectively creating the room to accommodate the appropriate key. Particular situations call for specific key types. Some of the more common types of keys are:

- square key;
- gib-head key;
- feather key;
- Woodruff key.

Figure 2 shows two orthographic views of a shaft and a hub. Draw full size:

- a) an isometric view of a gib-head key that would fit the given shaft and hub; (3)
- b) an isometric view of an appropriate feather key with countersunk holes at both ends; (4)
- c) an isometric exploded view of the shaft, the hub and a square key, showing clearly the sequence of assembly; (8)
- d) a sectional view along the axis of the shaft and hub showing an assembled shaft, hub, and Woodruff key (show the area around the key in local section). (5)

(Total: 20 marks)

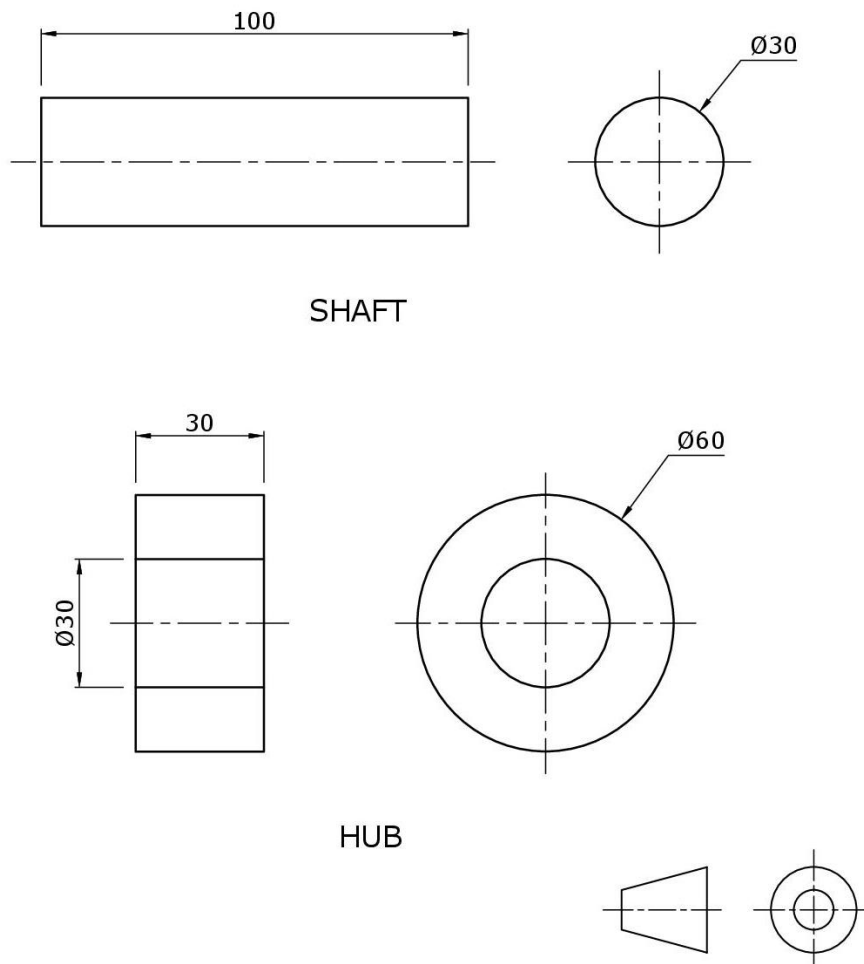

Figure 2

Question 3.

Positive locking devices are used in conjunction with fasteners to prevent or reduce the possibility of working loose from vibration. Figures 3a and 3b show two orthographic views of a tab washer and a locking plate respectively.

You are requested to:

- a) draw, approximately full size, a well-proportioned freehand isometric sketch to illustrate how the tab washer is used to lock the movement of the assembled nut; (8)
- b) draw, approximately full size, a well-proportioned freehand isometric sketch to illustrate how the locking plate is used to lock the movement of the assembled nut; (8)
- c) add motion arrows and annotations to enhance your illustrations. (4)

(Total: 20 marks)

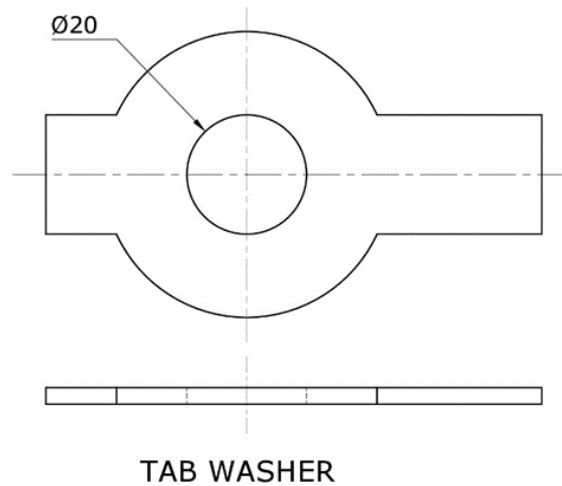

Figure 3a

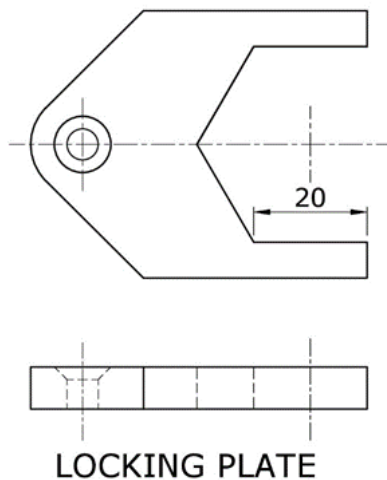

Figure 3b

Please turn the page.

Question 4.

The quality of any finished surface has a direct connection with the function and wear of the component. Machined surface finishes vary considerably in quality, and the maximum roughness acceptable is quoted on the machined surface.

- a) Draw and label the **THREE** surface texture symbols used to indicate the following:
- i. any manufacturing process is permitted; (1)
 - ii. material removal is required; (1)
 - iii. material removal is **not** permitted. (1)
- b) Draw, Figure 4a(i), 4a(ii) and 4a(iii), to a suitable size.
- i. In the drawings 4a(i) and 4a(ii), indicated by the arrow on the surface; show the direction of lay, in association with the machining symbol of the process of your choice. Also show the direction of lay or pattern on the given plan. (3)
 - ii. In the drawing 4a(iii), indicated by the arrow on the surface; show that the surface is to be grinded to a value of surface roughness of (0.2). Include the representation of the specific process or production method. Also show the direction of lay on the given plan. (2)

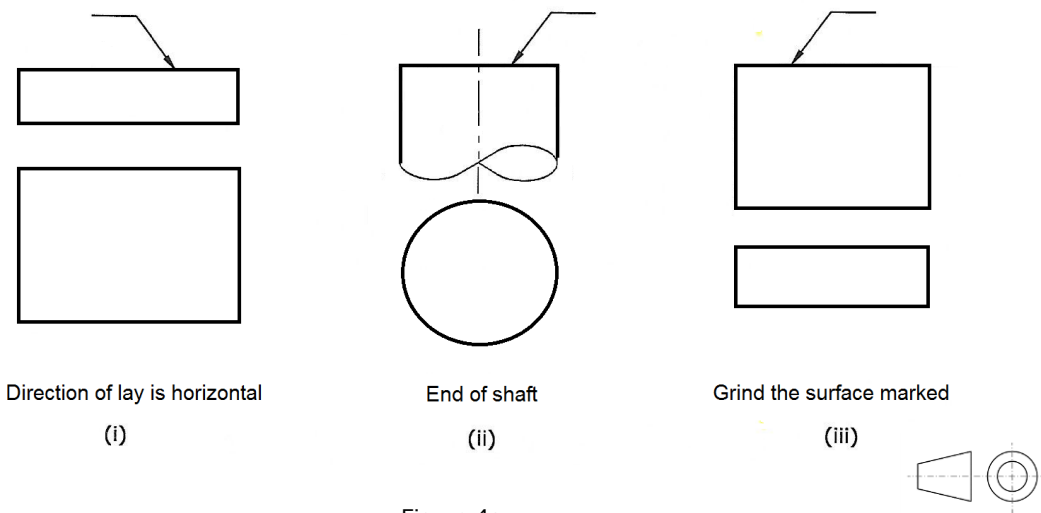

Figure 4a

c) Figure 4b shows a sectional view of a cast iron bearing block.

- A substantial amount of the surface texture of the bearing block is to remain in its original state (cast iron finish).
- The bearing hole is to be bored.
- The area around the retaining bolts is to be spot faced.
- The retaining bolts holes are to be drilled.
- The base is to be milled.

You are requested to:

- i. Copy the given drawing to a suitable scale. (2)
- ii. Convert the annotations into surface texture symbols. (5)
- iii. Use the table given in Figure 4c to suggest the value of surface roughness for each instance. (5)

Note:

The spot facing operation is to be carried out by means of an end mill.

(Total: 20 marks)

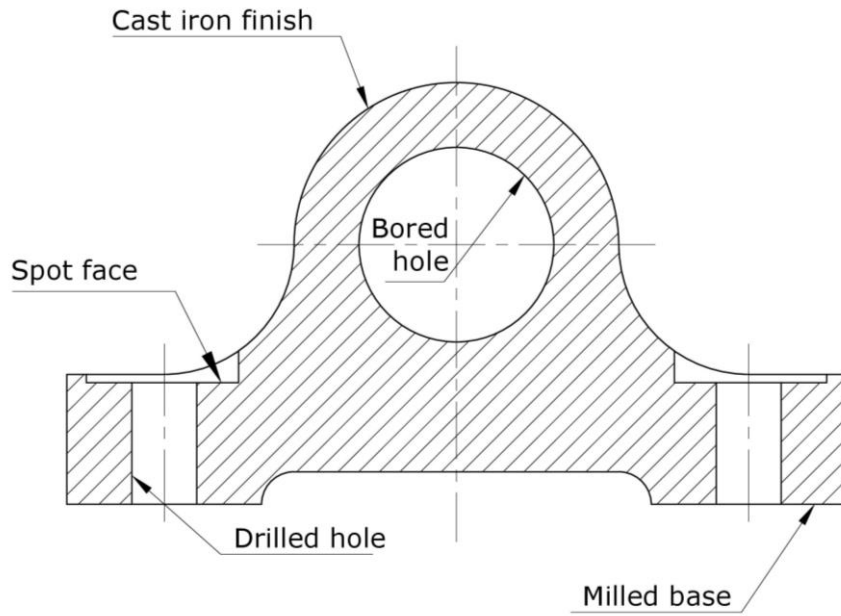
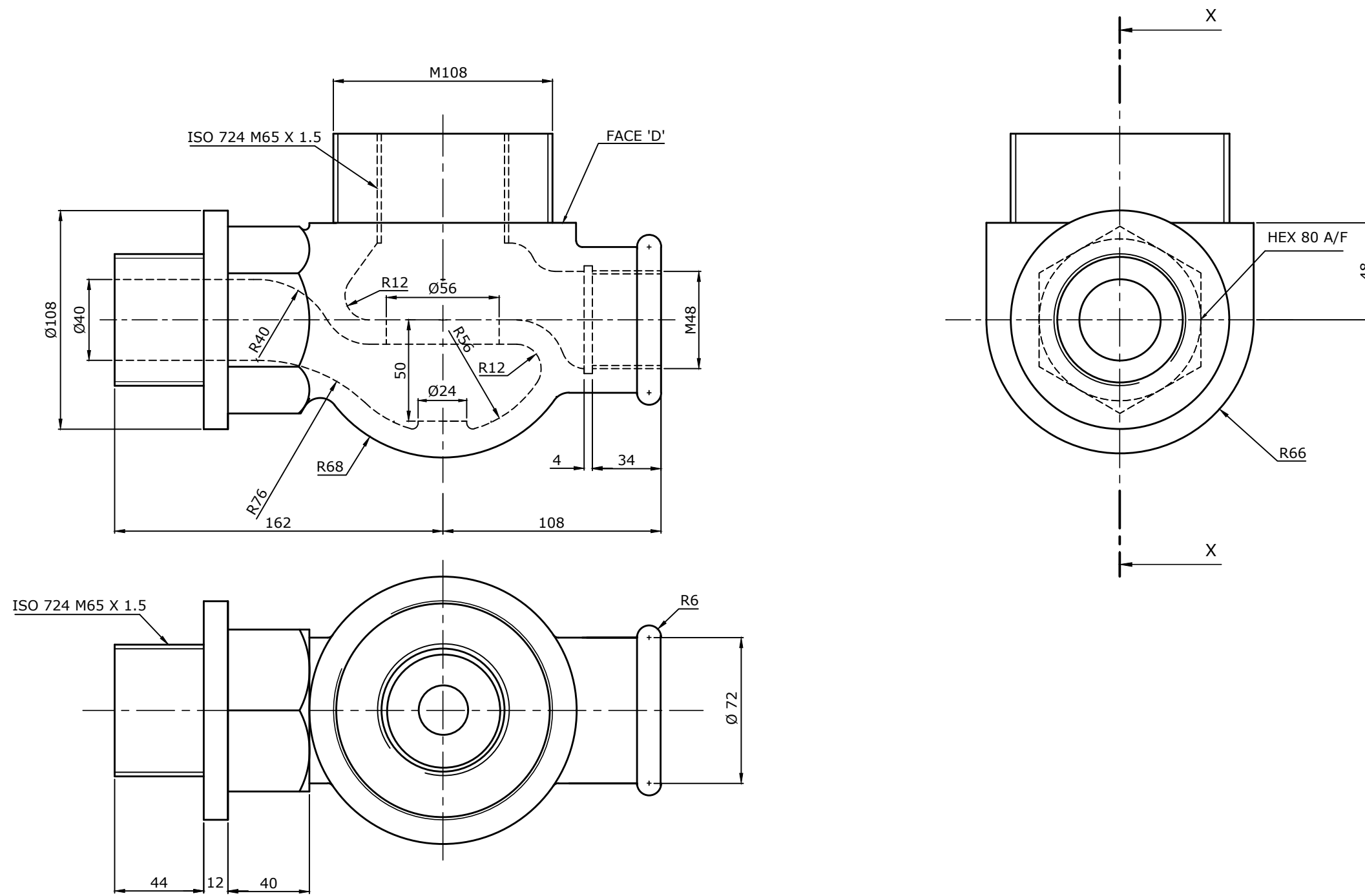

Figure 4b

Sand-Casting	Drilling	Boring	Milling	Lapping	Honing	Micrometers
						0.025
						0.05
						0.1
						0.2
						0.4
						0.8
						1.6
						3.2
						6.3
						12.5
						25
						50
Approximate Ra surface roughness ranges obtainable by some common production methods.						

Figure 4c



VALVE BODY (Item 1)

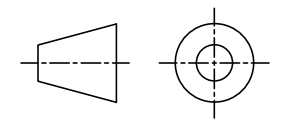

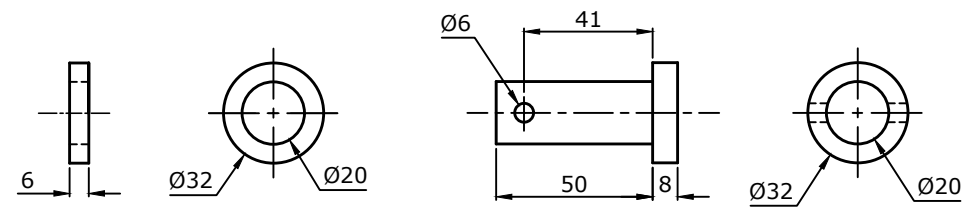

WASHER (Item 8)

FULCRUM PIN (Item 7)

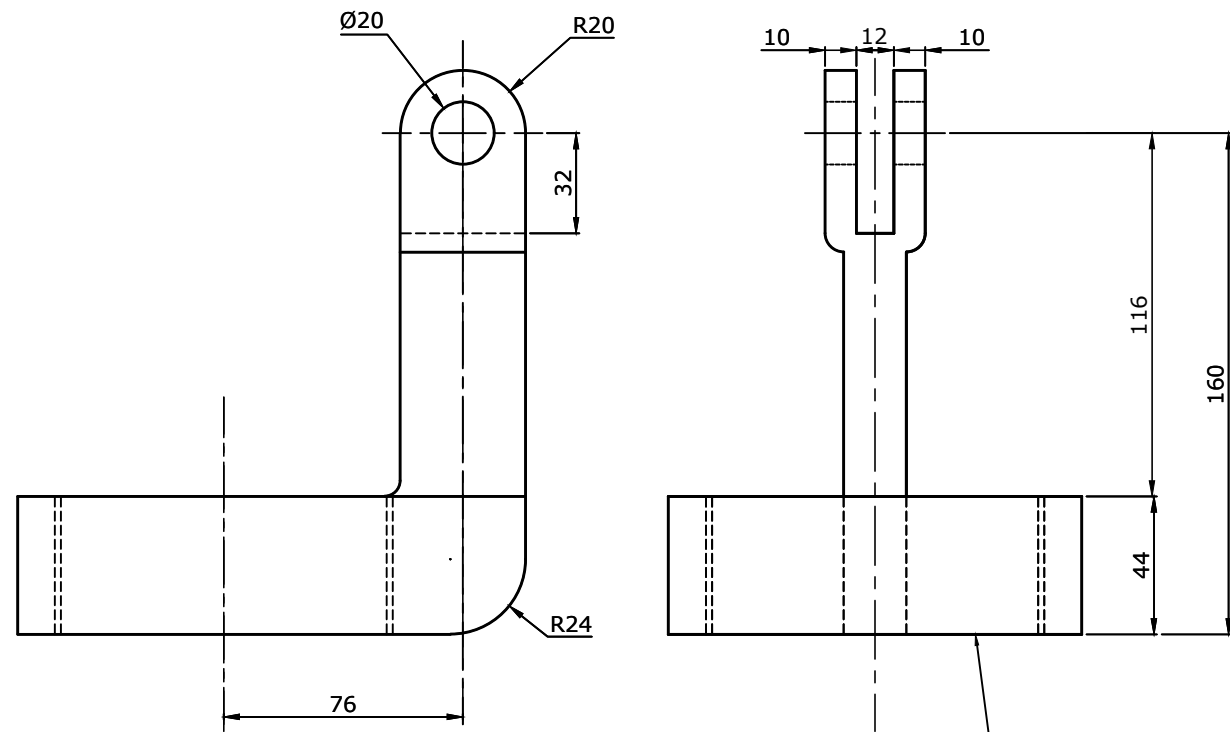

FULCRUM NUT (Item 5)

VALVE SEAT (Item 3)

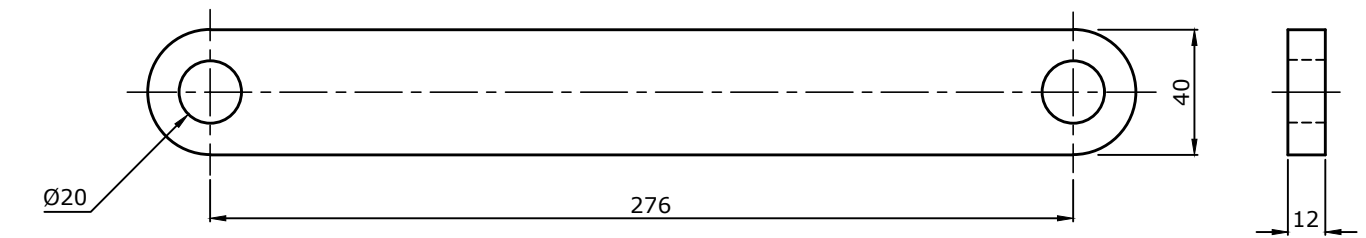
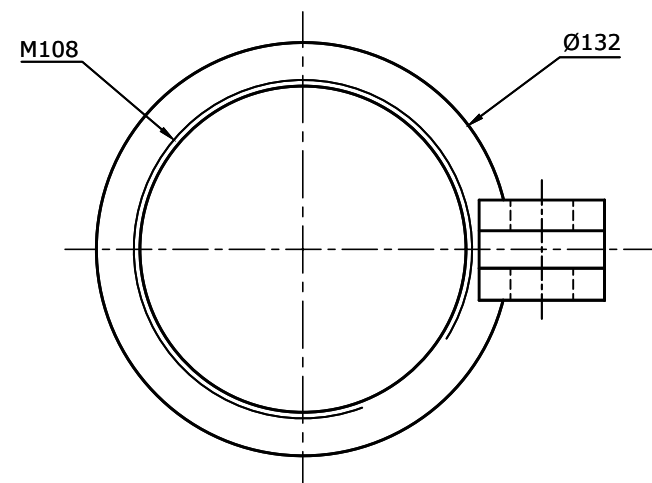

OPERATING LEVER (Item 6)

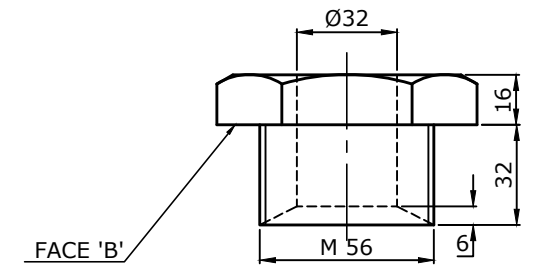

GLAND (Item 4)

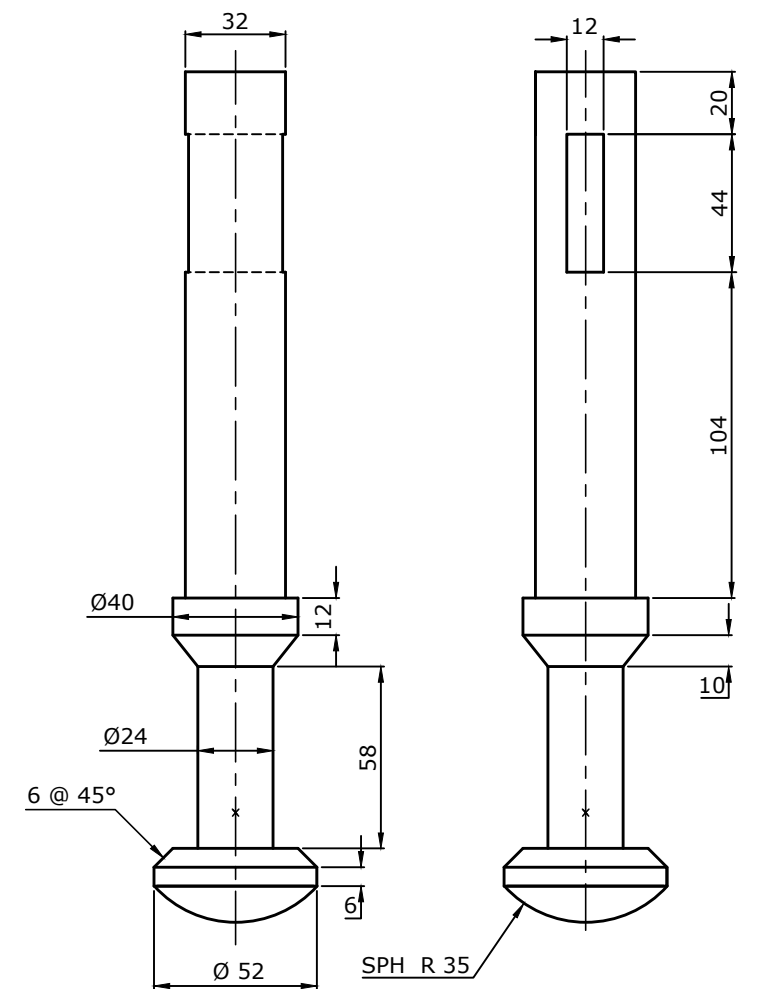
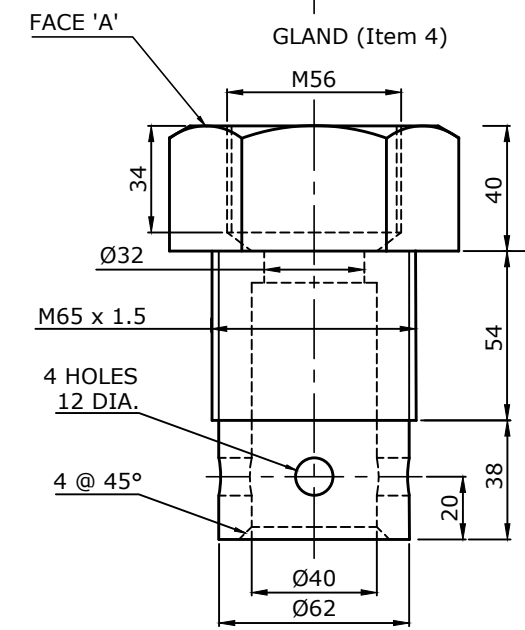
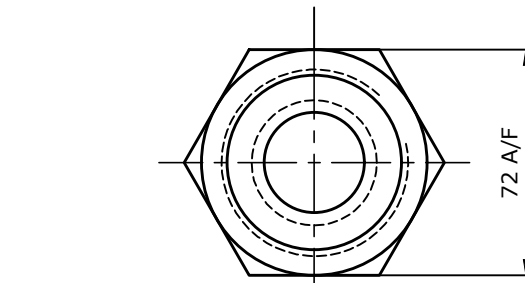

VALVE SPINDLE (Item 2)

