



Subject:	Engineering Drawing/Graphical Communication
PAPER NUMBER:	I
DATE:	28 th May 2024
TIME:	4:00 p.m. to 7:05 p.m.

Directions to Candidates

Write your index number where indicated at the top of all drawing sheets.

Attempt any **FIVE** questions.

Programmable calculators cannot be used.

Unless otherwise stated:

- a. drawings should conform to B.S or equivalent (ISO) standards;
- b. all dimensions are in millimetres;
- c. all answers are to be accurately drawn with instruments;
- d. all construction lines must be left in each solution;
- e. drawing aids may be used.

Dimensions not given should be estimated.

Careful layout and presentation are important.

Marks will be awarded for accuracy, clarity and appropriateness of constructions.

Question 1.

An illustration of a double right cone cut by a plane, which is parallel to its axis, is shown in Figure 1a. Dimensions and other details are given in Figure 1b. You are requested to:

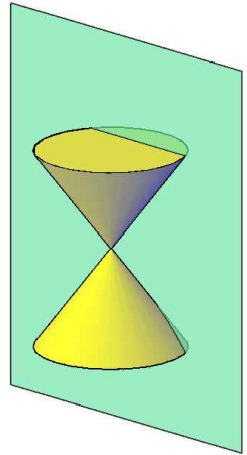

Figure 1a

- a. Copy the orthographic views given in Figure 1b; (2)
- b. draw, by construction, the focal spheres in the front elevation; (3)
- c. locate the directrices, the vertices and the foci of the conic sections; (2)
- d. project $D_1 D_2, V_1 V_2$ and $F_1 F_2$ from the front to the end elevation; (1)
- e. draw the conjugate axis and the auxiliary circle in the end elevation; (1)
- f. construct the two conic sections by using the intersecting arcs method; (5)
- g. state the name of the conic sections; (1)
- h. state the ratio of eccentricity of the conic sections; (1)
- i. draw an isometric view of the cut cones showing clearly the two sections; (4)
the isometric scale is not required.

(Total: 20 marks)

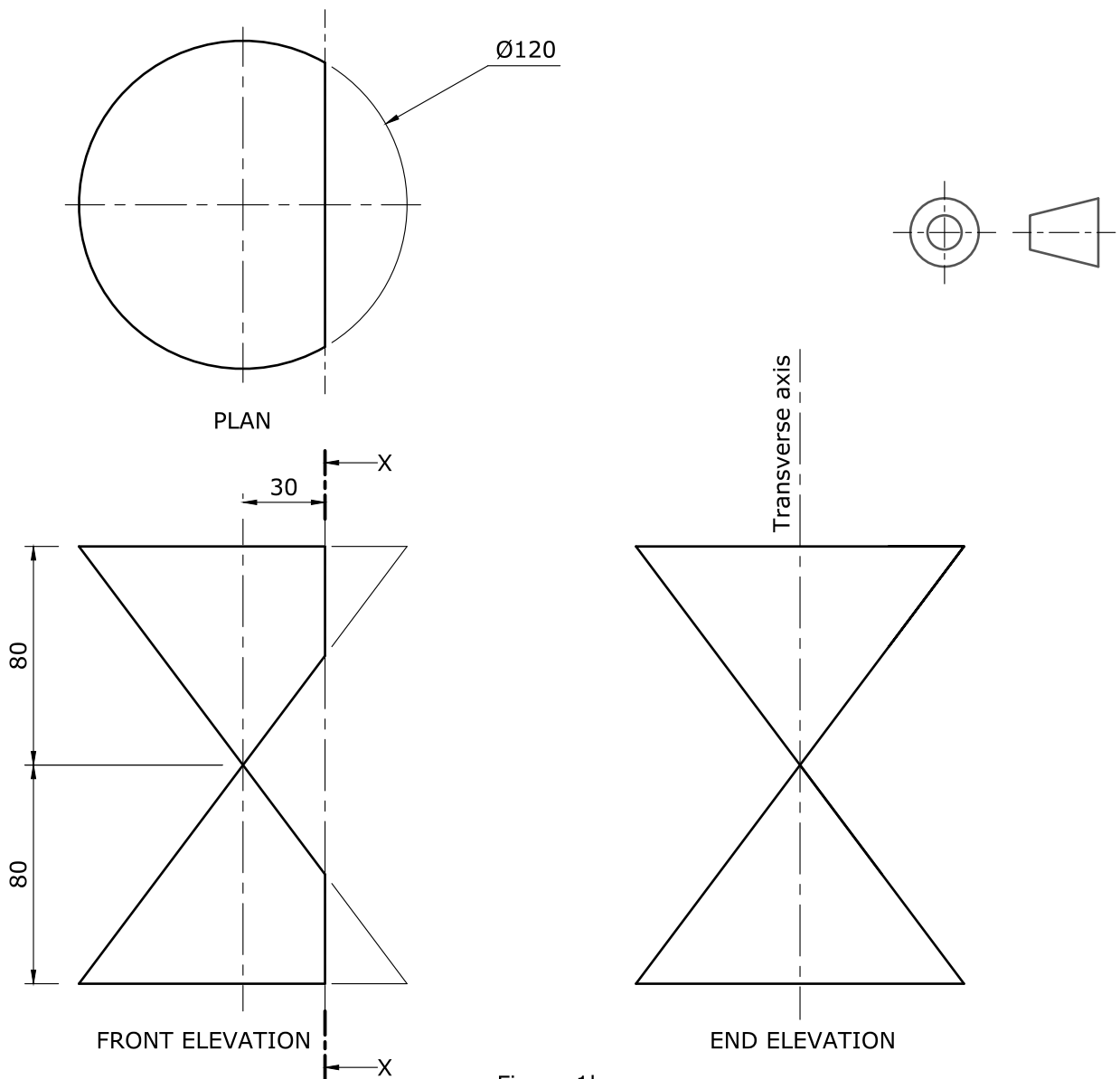

Figure 1b

Question 2.

Figure 2a shows an illustration of two identical helical fire escape chutes which have a rectangular 'U' shape cross section. From the first floor to the ground floor the helix turns a total of 360°. Details about the cross section, the pitch, the outside diameter of the helices and the distance between their axes are given in Figure 2b.

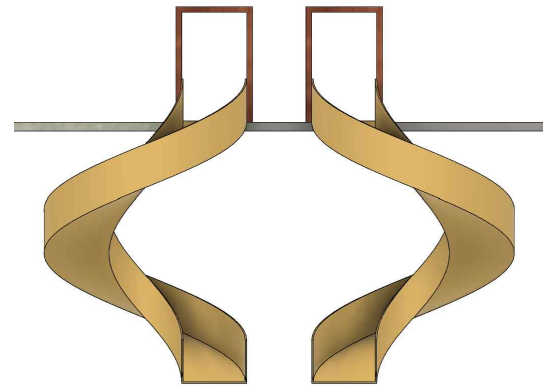

Figure 2a

You are requested to:

- a. copy Figure 2b to a scale of 1:20; (2)
- b. construct one turn of both helical chutes; (12)
- c. line in the visible outlines; (4)
- d. line in the hidden detail; (1)
- e. label the right-hand and the left-hand helical chutes. (1)

Note: The dimensions in Figure 2b are in millimetres.

(Total: 20 marks)

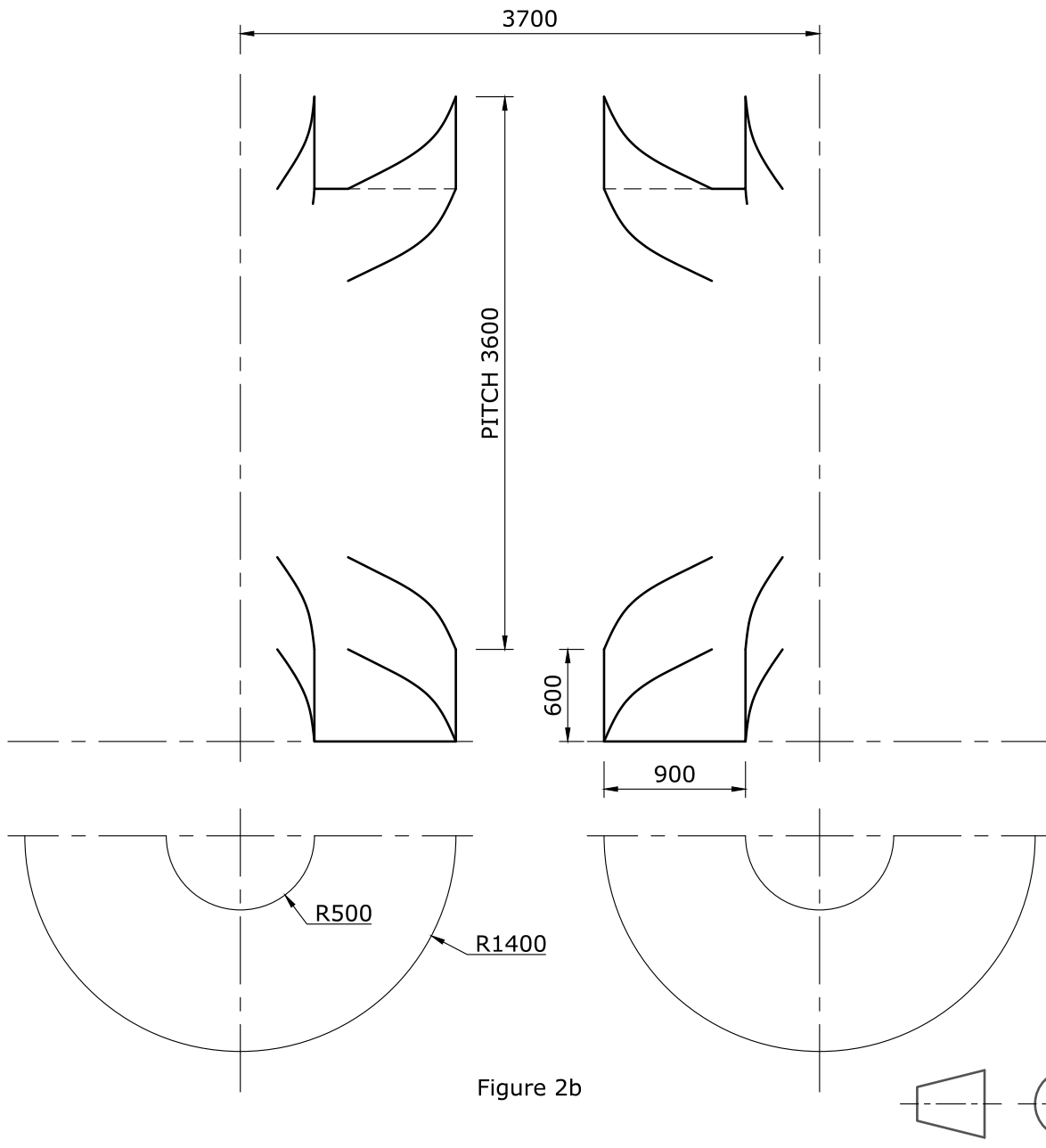

Figure 2b

Question 3.

Two orthographic views of a toy sailing boat are shown in Figure 3. The shaded area 'S', in the front elevation, indicates an oblique cut.

You are requested to:

- a. copy the given views; (2)
- b. project a first auxiliary elevation from the direction of arrow 'A'; (8)
- c. project a second auxiliary view of the complete boat to show the true shape of the shaded area 'S'. (10)

Note: Show hidden detail in the second auxiliary view only.

(Total: 20 marks)

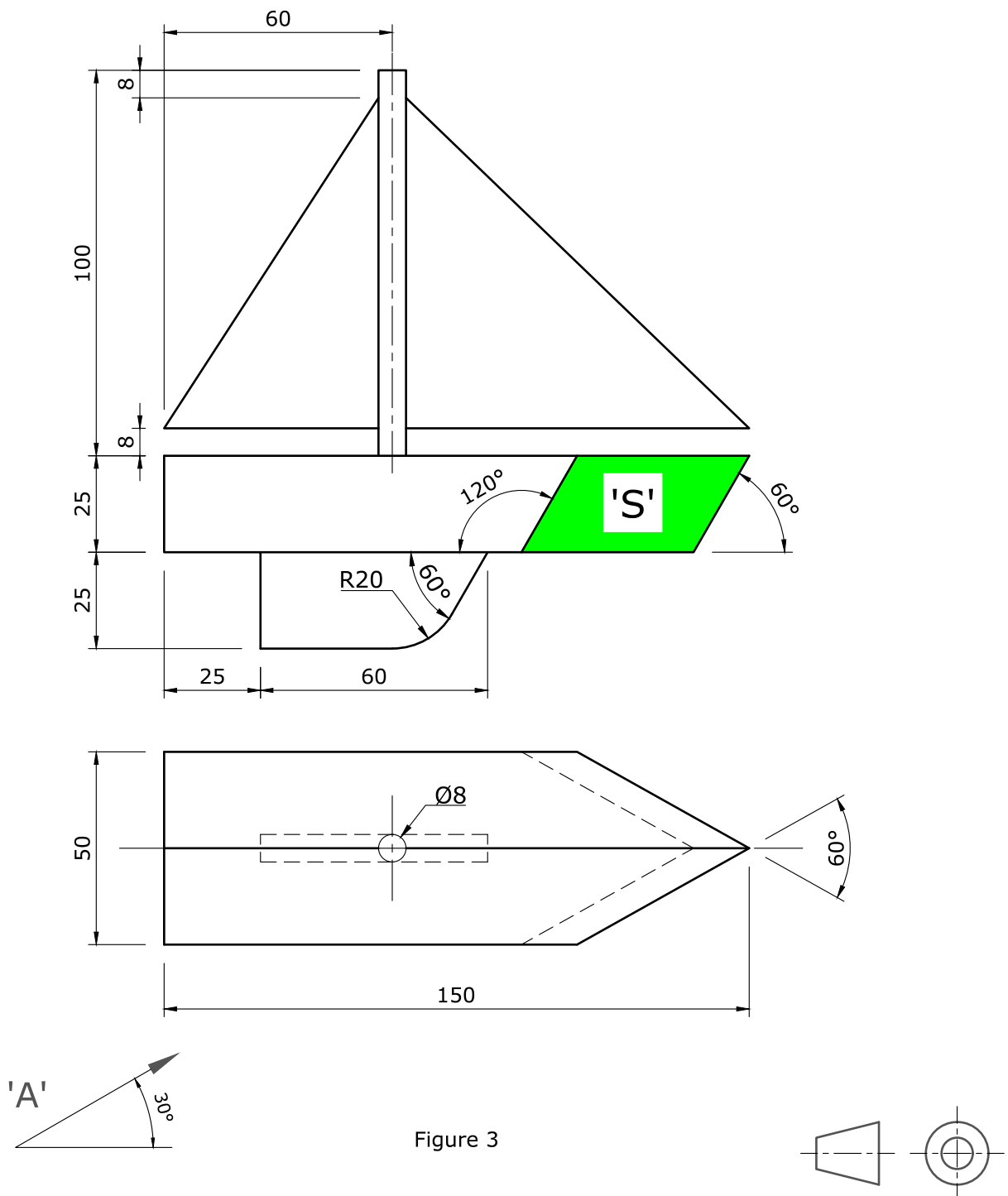

Figure 3

Question 4.

An illustration of a right cone intersecting a hemisphere is shown in Figure 4a. Two orthographic views of the intersecting solids, which are both resting on the horizontal plane, are given in Figure 4b.

You are requested to:

- a. copy the given orthographic views; (2)
- b. complete the plan, showing clearly the curve of intersection; (6)
- c. complete the front elevation; (6)
- d. draw an end elevation as seen from the direction of arrow 'B'. (6)

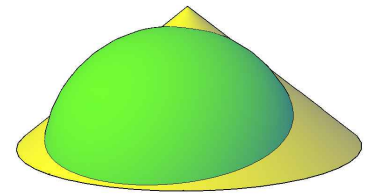

Figure 4a

Note: Show hidden detail in the end elevation only.

(Total: 20 marks)

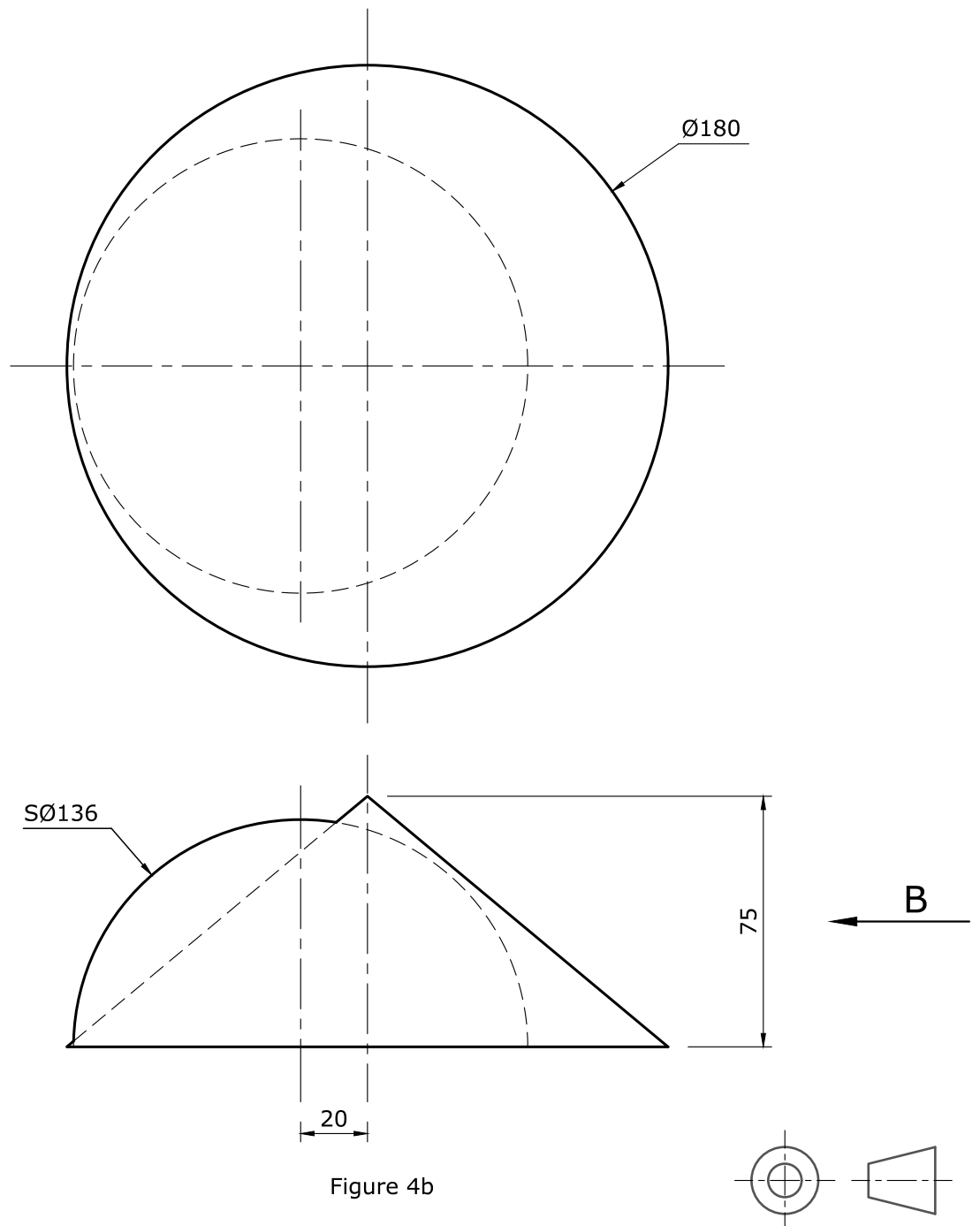

Figure 4b

Question 5.

Figure 5a and 5b illustrate an assembled and an exploded view of a rectangle to round transition piece. A front elevation and a plan of the transition piece are given in Figure 5c.

You are requested to:

- a. draw a small isometric freehand sketch of the transition piece; (1)
- b. sketch the seam line and the crease lines; (1)
- c. label using letters and numbers; (1)
- d. copy the orthographic views given in Figure 5c; (2)
- e. draw the crease lines in both views; (2)
- f. construct the necessary true lengths; (6)
- g. construct the surface development of the transition piece. (7)

Note: Take the seam line along 1-X.

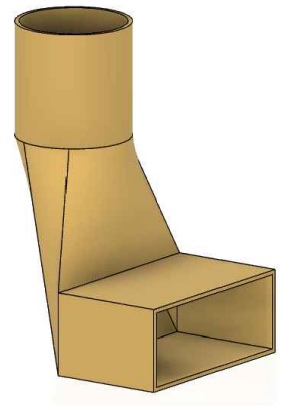

Figure 5a

(Total: 20 marks)

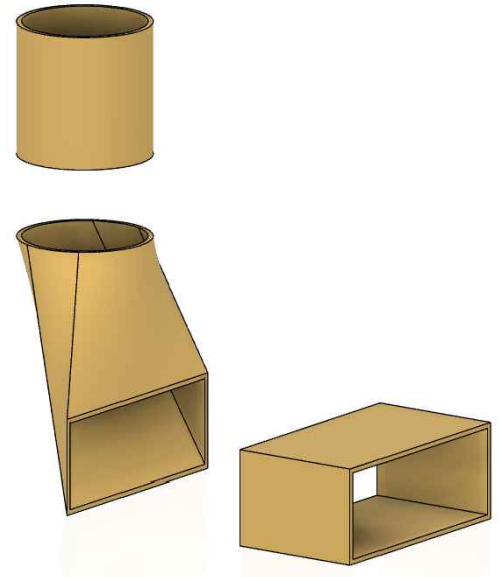
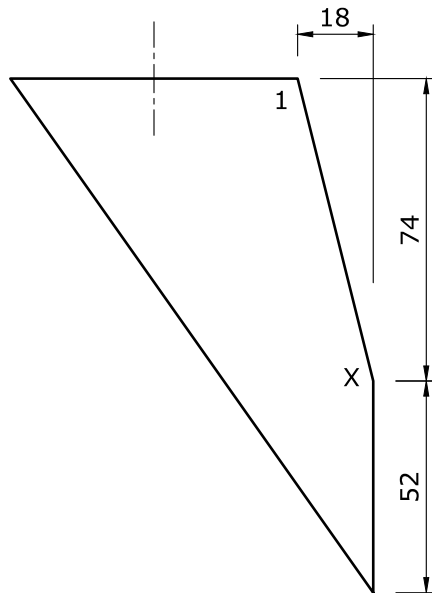

Figure 5b

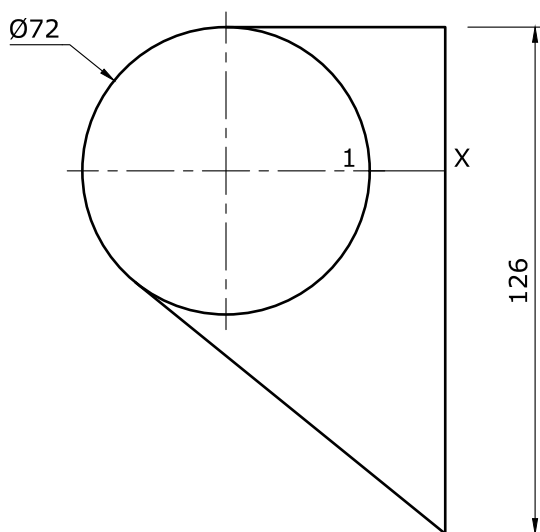
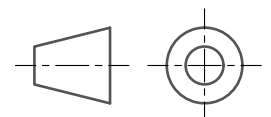

Figure 5c



Question 6.

A Howe truss structure with three suspended loads is shown in Figure 6a. A detailed version of the structure is shown in Figure 6b.

You are requested to:

- copy the space diagram using a scale of 10 mm representing 1 m and label the frame using Bow's notation; (4)
- draw a scale diagram using a scale of 50 mm representing 100 kN; (4)
- construct a link polygon to determine the magnitude of the left and right reactions; (4)
- present a table showing the magnitude of all the members and stating which are in tension and which are in compression. (8)

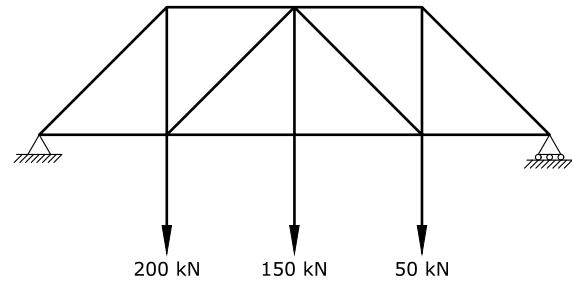

Figure 6a

(Total: 20 marks)

SPACE DIAGRAM SCALE: 10 mm REP 1 m

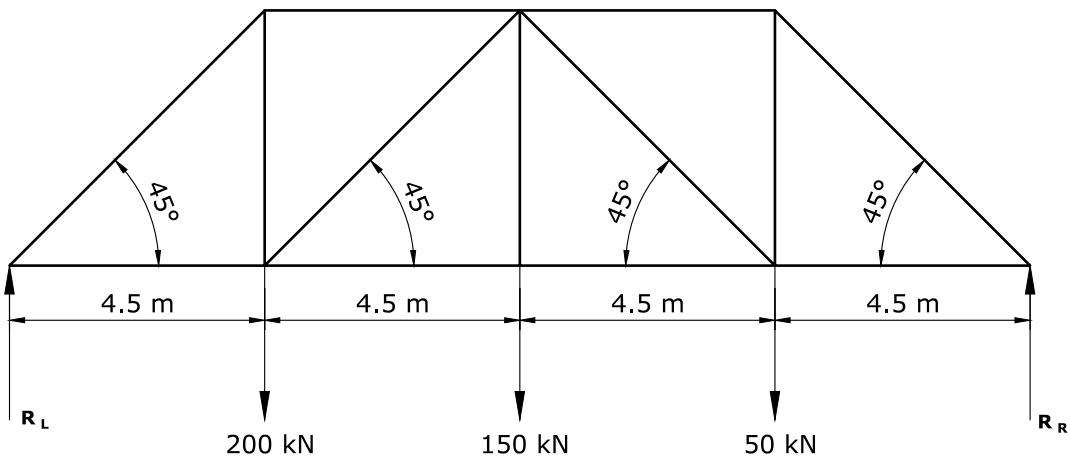

Figure 6b



L-Università
ta' Malta

**ADVANCED MATRICULATION LEVEL
2024 FIRST SESSION**

SUBJECT:	Graphical Communication
PAPER NUMBER:	II
DATE:	29th May 2024
TIME:	9:00 a.m. to 12:05 p.m.

Directions to Candidates

Write your index number where indicated at the top of all drawing sheets.

Attempt all **FOUR** questions.

Programmable calculators **cannot** be used.

Unless otherwise stated:

- drawings should conform to B.S. or equivalent (ISO) standards;
- all dimensions are in millimetres;
- answers are to be accurately drawn with instruments;
- all construction lines must be left on each solution;
- drawing aids may be used.

Dimensions not given should be estimated.

Careful layout and presentation are important.

Marks will be awarded for accuracy, clarity and appropriateness of constructions.

Colour/shading should be used where appropriate.

Mark allocations are shown in brackets.

Question 1 carries 34 marks. Questions 2, 3, and 4 carry 22 marks **each**.

Question 1.

Figure 1 shows two orthographic views of a Petrol Station. These orthographic views feature the proportion of every element within the entire setting. Use this information to construct a two-point estimated perspective of this setting. The arrows on the front elevation indicate the viewing direction.

- a) Using **THREE** preliminary sketches, explore alternative positions of the horizon line and identify the one which best describes the spaciousness of the entire area. (3)
- b) Based on the choice made in part (a), use a suitable scale to produce the required illustration on a single side of an A2 size paper, making the best use of the space available. (26)
- c) Enhance your drawing by colouring small areas of the different items appearing in your illustration. (5)

Notes:

- The main structure is made of reinforced concrete.
- The pumps' main housing is made of polished stainless steel.

(Total: 34 marks)

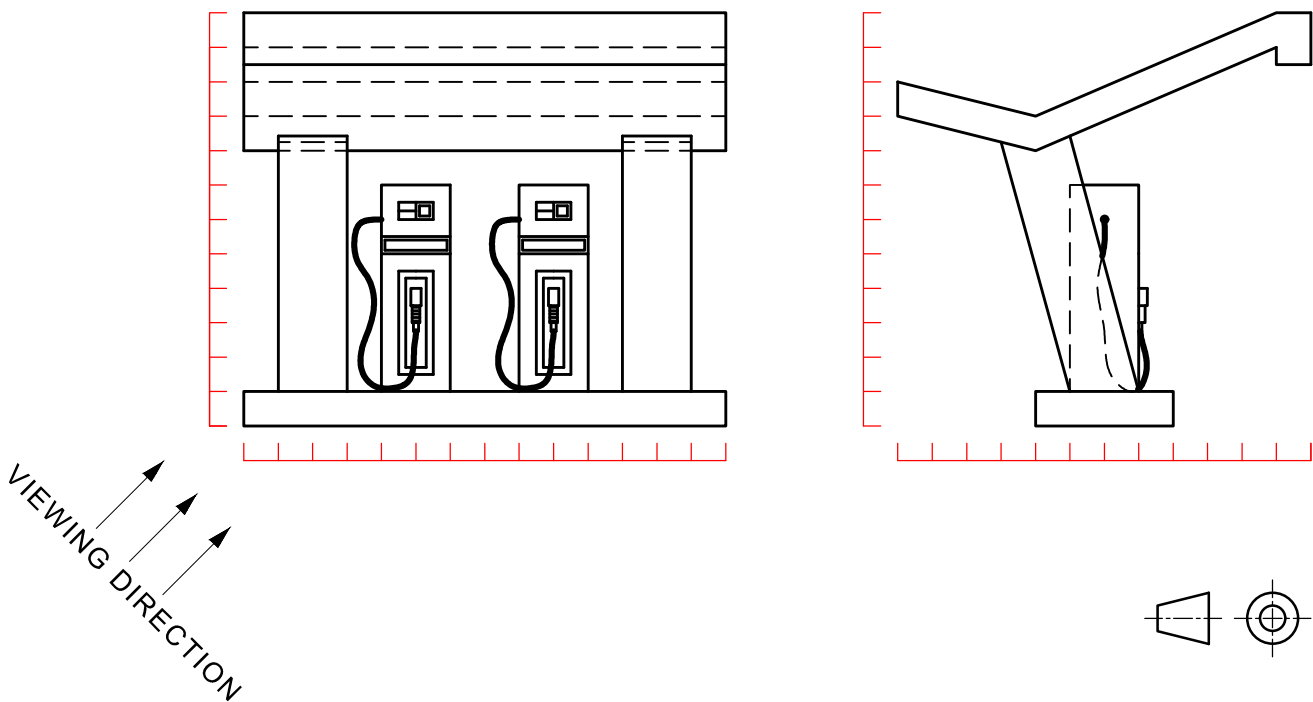

Figure 1

Question 2.

Transportation is responsible for 30% of our greenhouse gas emissions, and 40% of our energy use. Owning an electric vehicle (EV) substantially aids in reducing both emissions and energy use. Table 1 shows the advantages of investing in an electric vehicle.

Table 1

Operations and maintenance	Can save you around €2000 annually on fuel and maintenance. There is no need for oil and antifreeze change. Totally silent operation.
Charging	Can be charged from the comfort of your garage or at any public charging point around Malta and Gozo.
Driving range	EV's have a single-charge range of around 100 - 450 Km.
Environmental benefits	EV's produce no tailpipe emissions, contributing to better air quality.

Table 2 shows a comparison in average generative CO₂ emissions (L/Km) between different types of vehicles.

Table 2

Type of vehicle	Hatchback	Sedan	Crossover	SUV
Conventional fuel vehicle	300	400	500	650
Hybrid	250	300	350	450
EV	200	250	300	350

- a) Design an infographic poster to show the information in both Tables. The information in Table 1 should include relevant pictograms, while the information in Table 2 is to be presented via a 3D bar graph. The poster should include relevant labelling, using suitable typefaces. (14)
- b) In a separate section within the same A2 sheet, provide preparatory sketches for the used pictograms. (8)

(Total: 22 marks)

Question 3.

Design a sequence of six illustrations to show the preparation of a packet of instant noodles. These illustrations will be printed on the back of the noodles packet as instructions. The instant noodles packet contains a block of dried noodles, one packet of seasoning powder, one packet of soy sauce, one packet of sweet chilli sauce, and one packet of oil.

The illustration steps that you need to design must adhere to the following six steps:

1. Open the packet of noodles and sort the contents beside each other on the tabletop.
2. Bring 400ml of water to boil in a pan.
3. Add the block of dried noodles and the seasoning powder to the water and simmer for three minutes.
4. Remove the noodles from the water and drain them well using a colander.
5. Place the drained noodles in a bowl and mix them well to the soy sauce, chilli sauce, and the oil.
6. Put the mixture on a plate, add some fried onion rings, and serve.

The pictures below (Figure 2) might help you out in planning and designing this sequence of illustrations. You may opt not to use them.

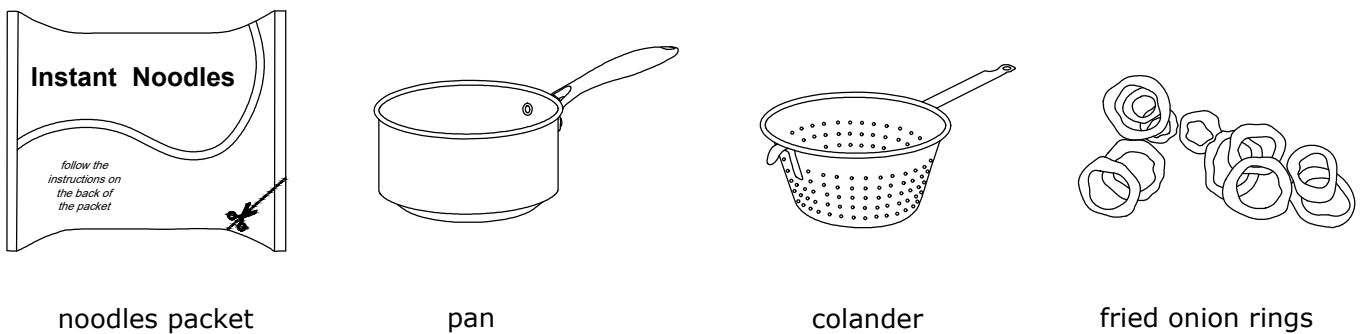

Figure 2

It is suggested that you present your work as shown below (Figure 3):

(Total: 22 marks)

Preparing Instant Noodles

<div style="border: 1px solid black; height: 150px; width: 100%;"></div> <p style="text-align: center; margin-top: 5px;">space for preparatory sketches</p>		step 1	step 4	
		step 2	step 5	
		step 3	step 6	

Figure 3

Question 4.

Five orthographic views of a leaf blower are shown in Figure 4 below.

You are requested to:

a) make a well-proportioned pictorial (3D) freehand drawing of this leaf blower; (14)

b) colour and shade your drawing using the following instructions: (8)

- main body - durable plastic (light grey);
- mesh - aluminium (polished);
- central cylindrical hose - durable plastic (light brown);
- truncated conical nose and battery - durable plastic (black);
- handle and base - durable plastic (light brown).

(Total: 22 marks)



Figure 4

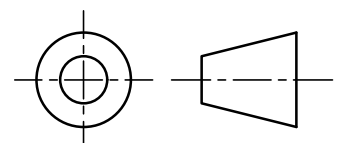

SUBJECT:	Engineering Drawing
PAPER NUMBER:	II
DATE:	29 th May 2024
TIME:	9:00 a.m. to 12:05 p.m.

Directions to Candidates

Write your index number where indicated at the top of all drawing sheets.

Attempt **Question 1** and any other **TWO** questions.

Programmable calculators **cannot** be used.

Unless otherwise stated:

- drawings should conform to B.S. or equivalent (ISO) standards;
- all dimensions are in millimetres;
- all answers are to be accurately drawn with instruments;
- all construction lines must be left on each solution;
- drawing aids may be used.

Dimensions not given should be estimated using engineering judgement.

Careful layout and presentation are important.

Marks will be awarded for accuracy, clarity and appropriateness of constructions.

Mark allocations are shown in brackets.

Question 1 carries 60 marks. Questions 2, 3, and 4 carry 20 marks.

Question 1.

A pressure relief valve is a safety device designed to protect a pressurized vessel or system during an overpressure condition. The pressure relief valve protects by venting fluid of an over pressurized system to atmosphere or by bypassing the fluid to the storage reservoir. A pressure relief valve must be capable to operate independently of power and system controls.

Two exploded illustrations of the valve are shown in Figures 1a and 1b on the next page.

Details of the component parts of a relief valve, drawn in first angle projection, are shown on the A3 drawing sheets (Figures 1d and 1e). The component parts are assembled as follows.

- The body (Item 1) of the relief valve is held in the vertical position and the 52 mm diameter sphere (Item 2) is placed seated on 26 mm radius of the body.
- The 58 mm diameter x 14 mm end of the plunger (Item 3) is inserted in the 58 mm bore of the body with the 26 mm radius concave underside of the plunger resting on the 52 mm diameter sphere.
- The spring (Item 4) is fitted over the plunger resting on the 58 mm diameter step.
- The gland (Item 5) with the locknut (Item 6) is screwed on the gland thread. The assembly is screwed with the 56 mm internal diameter fitting over the 36 mm diameter end of the plunger. The gland nut is tightened to the required position and is then secured to the body by means of the locknut.

Draw, full size, a sectional elevation of the assembled relief valve, on the plane X-X.

The lower end of the plunger resting on the sphere is to be shown as a local section.

Notes:

- Hidden detail should not be shown.
- It is suggested that you start your drawing 20 mm above the title block (see Figure 1c).

(Total: 60 marks)

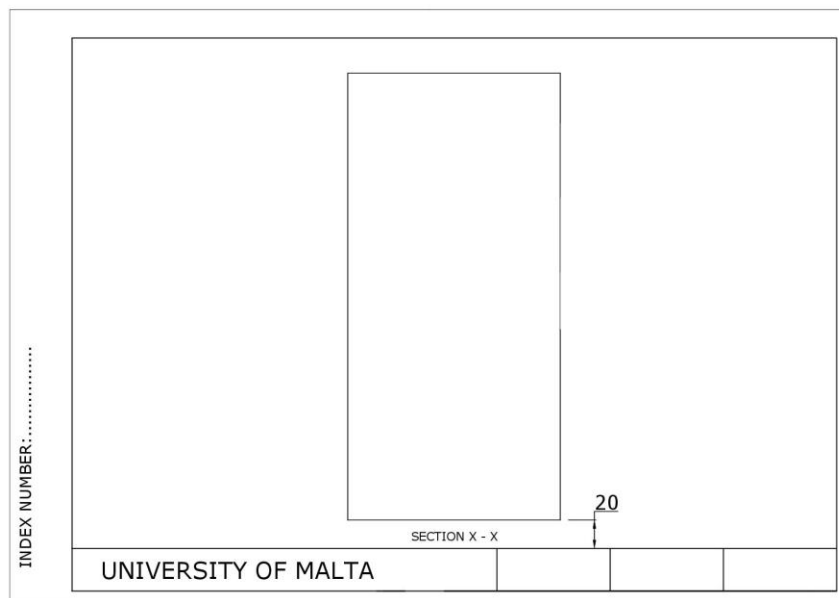

Figure 1c

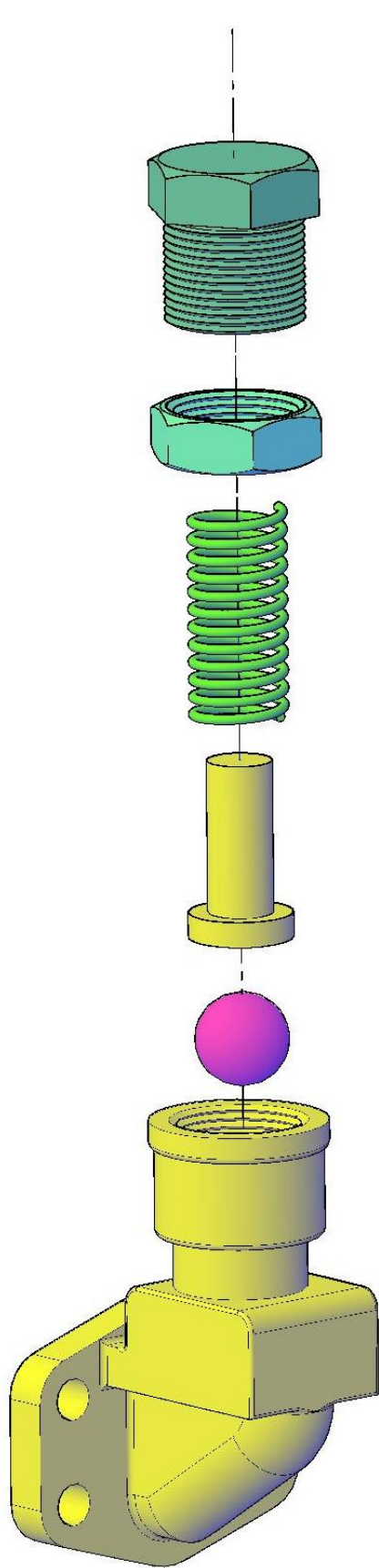

Figure 1a

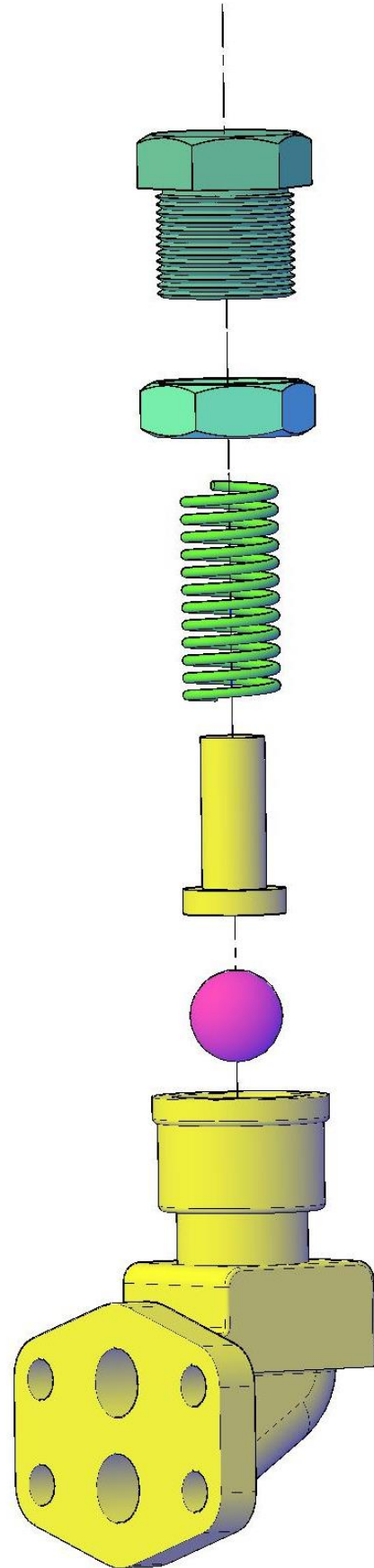

Figure 1b

Please turn the page.

Question 2.

An illustration of a cast iron bracket is given in Figure 2a. Two full size orthographic views of the bracket are given in Figure 2b (on the A3 sheet). You are requested to:

- a. copy, full size, the two orthographic views; (6)
- b. insert four linear dimensions; (4)
- c. label and dimension the counterbore, the spot face and the threaded hole; (3)
- d. indicate, by using the appropriate machining symbol, that the faces 'F' and 'A' are to be ground to the required surface roughness value of Ra 0,05. The lay is to be perpendicular to the plane of projection. (3)
- e. use the appropriate symbol to label face 'A' as datum A; (2)
- f. apply a geometric tolerance frame to the axis of the $\varnothing 50$ bore, this is to be parallel to datum A and its axis must be contained between two planes 0.1 mm apart. (2)

Note: Unless otherwise specified, the general dimension tolerance is ± 0.1 mm.

(Total: 20 marks)

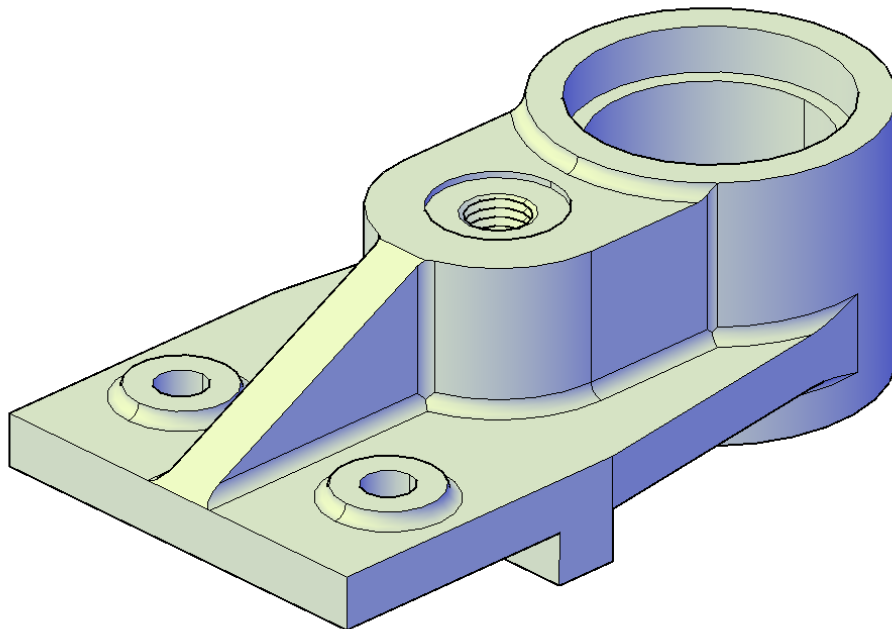

Figure 2a

Question 3.

A Hooke's joint is used to connect two shafts whose axis are intersecting. An illustration of the assembled joint, also known as Universal Coupling, is shown in Figure 3. You are requested to:

- a. draw a freehand shaded exploded isometric drawing of the coupling; (14)
- b. include centre lines to indicate the assembly sequence; (2)
- c. label the separate parts. (4)

(Total: 20 marks)

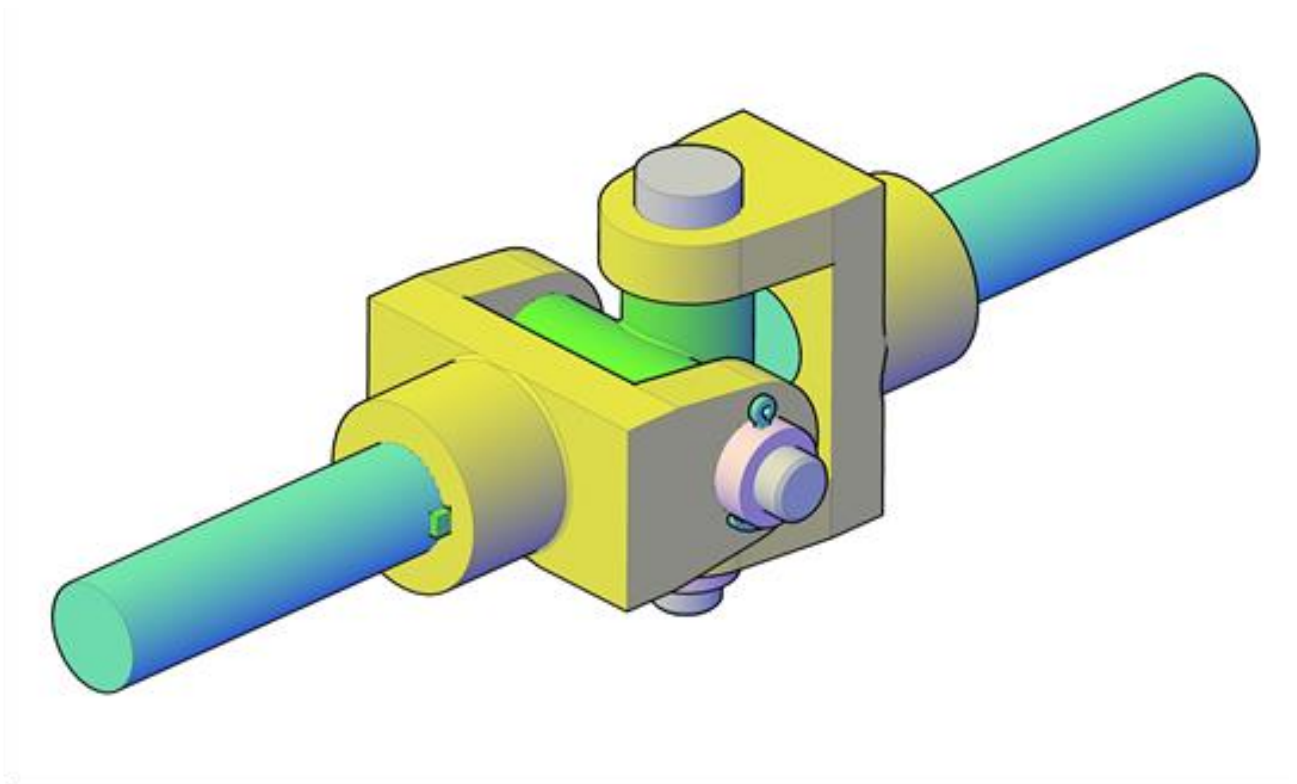

Figure 3

Please turn the page.

Question 4.

In the manufacturing industry, welding requirements are communicated by means of welding symbols. Both the designers and the welders follow the same standards so as to ensure that the final product is completed to the required specifications.

- a. Table 1 shows an illustration and a symbolic representation of a single-V butt weld. You are requested to use the same table format to represent the following designations:
- i. fillet weld on site; (2)
 - ii. square butt weld; (2)
 - iii. spot weld; (2)
 - iv. convex double-V butt weld. (2)

Table 1

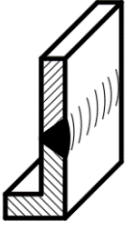
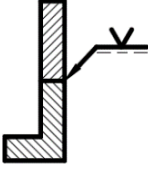
ILLUSTRATION	DESIGNATION	SYMBOLIC REPRESENTATION
	<p>SINGLE-V BUTT WELD</p>	

- b. Figure 4a and Figure 4b show an exploded and a fabricated Vertical Shaft Support respectively. The fabrication was carried out in the following sequence:
- the hollow cylinder was welded to the octagonal base plate all around by using a fillet with a concave surface.
 - the sides of the four webs were welded vertically to the cylinder and horizontally to the base plate. A fillet type of weld with a concave surface was used.

You are requested to:

- i. draw a front elevation and plan of the assembled shaft support; (4)
- ii. label all the welded joints in accordance with BS EN 22553 using the appropriate elementary and supplementary symbols. (8)

Notes:

- The octagonal base measures 120 mm AF. The length of the hollow Ø50 cylinder is 80 mm. The triangular webs measure 30 mm x 30 mm x 42 mm.
- Material thickness is 10 mm throughout.

(Total: 20 marks)

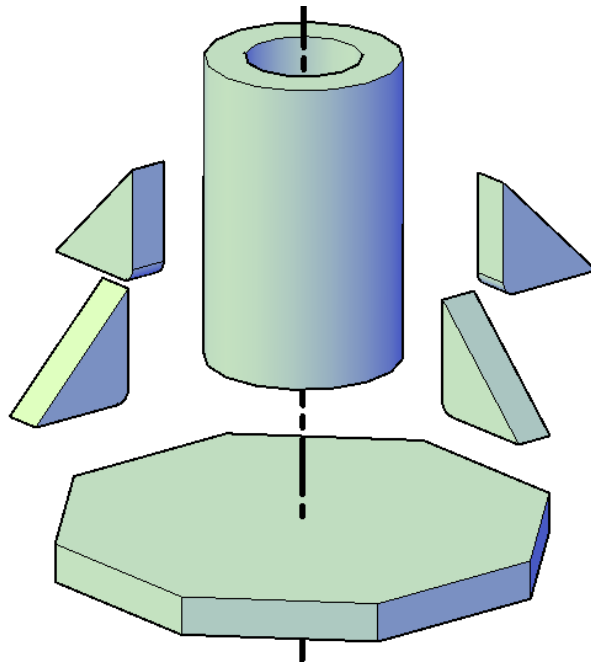

Figure 4a

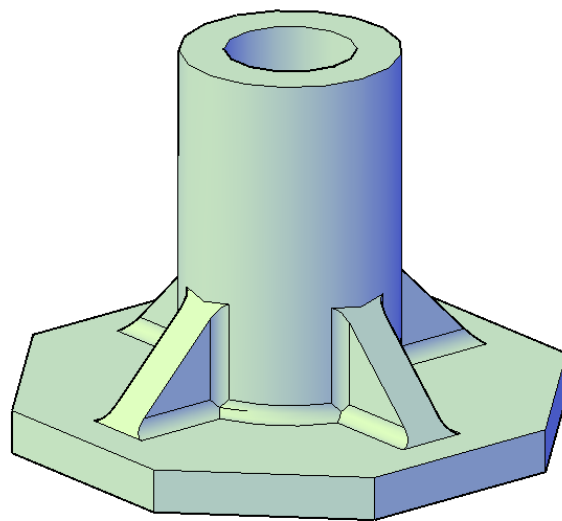
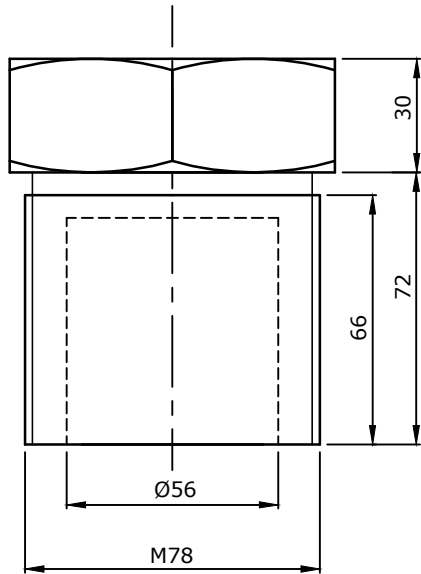
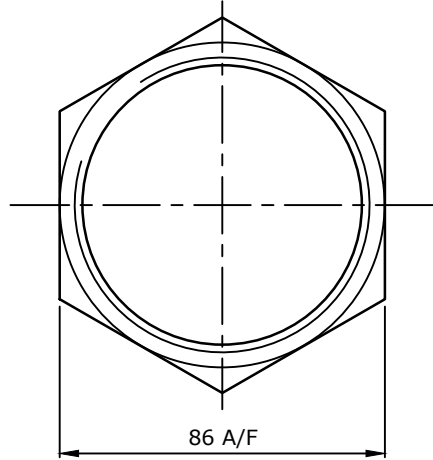
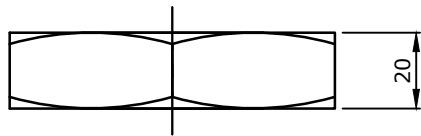

Figure 4b



GLAND (Item 5)



LOCKNUT (Item 6)

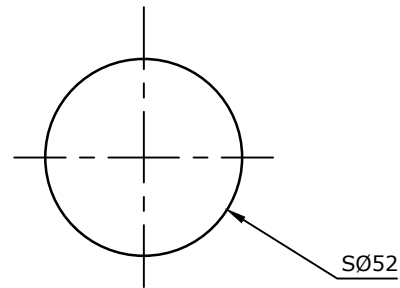

SPHERE (Item 2)

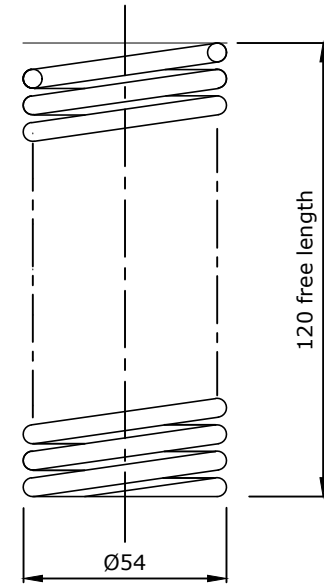

SPRING (Item 4)

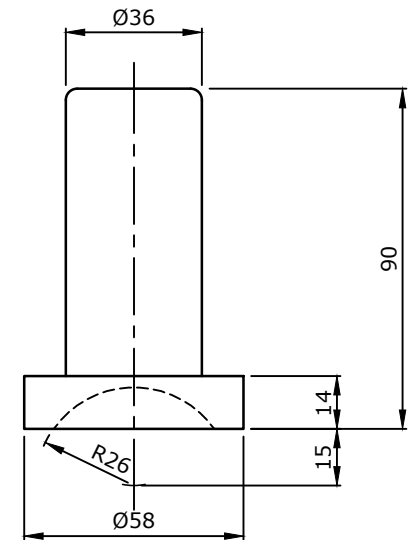

PLUNGER (Item 3)

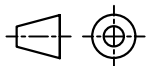

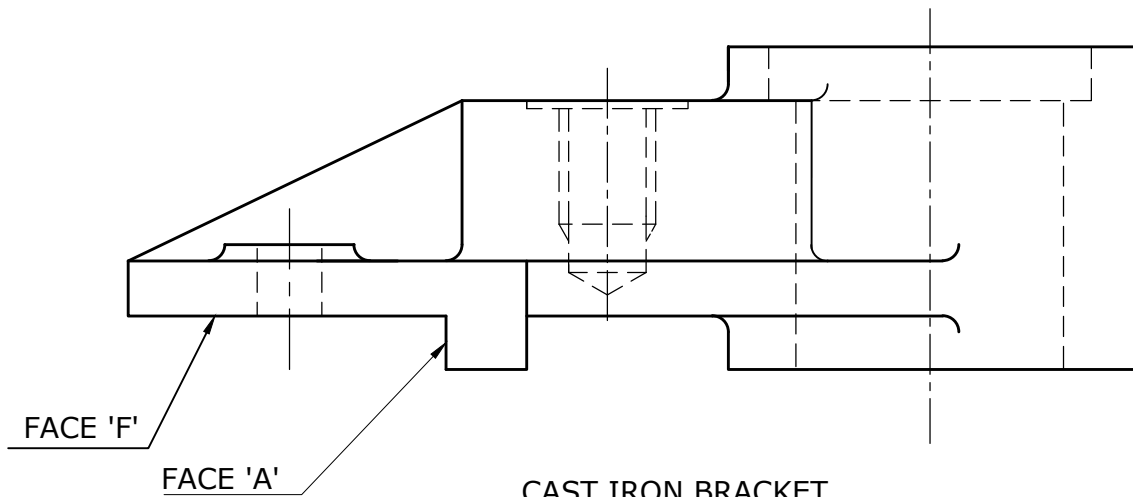
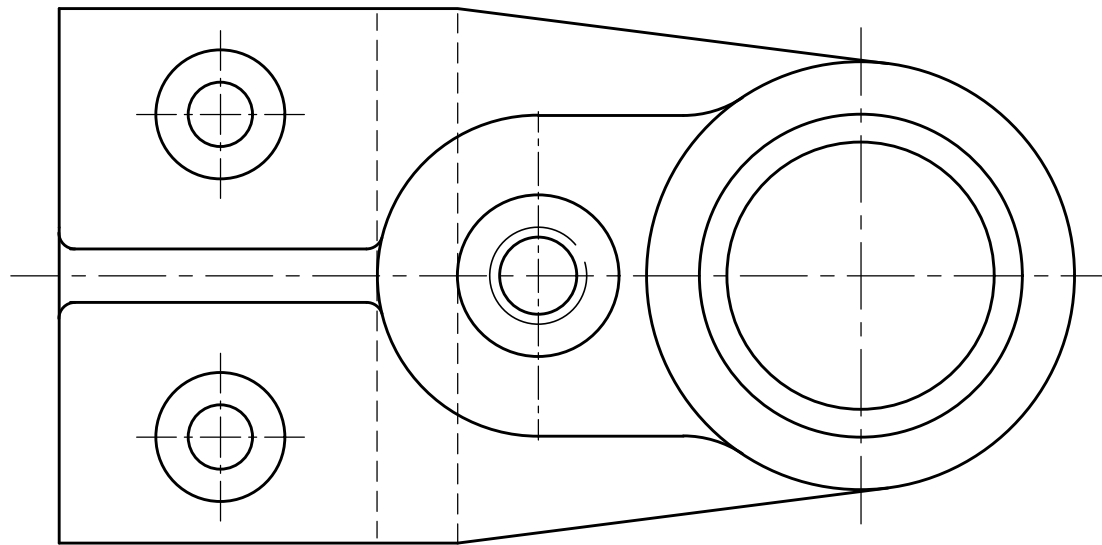

SCALE 1 : 1

