



SUBJECT:	Engineering Drawing/Graphical Communication
PAPER NUMBER:	I
DATE:	8 th June 2023
TIME:	9:00 a.m. to 12:05 p.m.

Directions to Candidates

Write your index number where indicated at the top of all drawing sheets.

Attempt any **FIVE** questions.

Programmable calculators cannot be used.

Unless otherwise stated:

- a. drawings should conform to B.S or equivalent (ISO) standards;
- b. all dimensions are in millimetres;
- c. all answers are to be accurately drawn with instruments;
- d. all construction lines must be left in each solution;
- e. drawing aids may be used.

Dimensions not given should be estimated.

Careful layout and presentation are important.

Marks will be awarded for accuracy, clarity and appropriateness of constructions.

Question 1.

The illustration in Figure 1a shows a transition piece designed to connect a cylindrical inlet to a square outlet.

Use the dimensions given in Figure 1b to:

- a. copy the given views; (2)
- b. construct a half-surface development of the cylinder; (4)
- c. construct the necessary true lengths; (4)
- d. construct a full surface development of the transition piece 'A'. (10)

Note: take the given J-J line as the seamline.

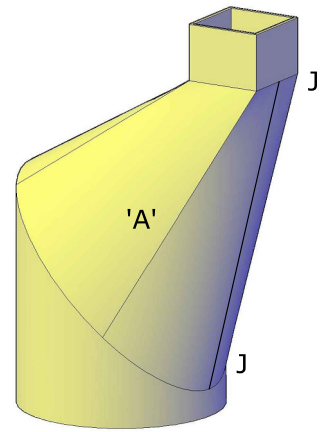

Figure 1a

(Total: 20 marks)

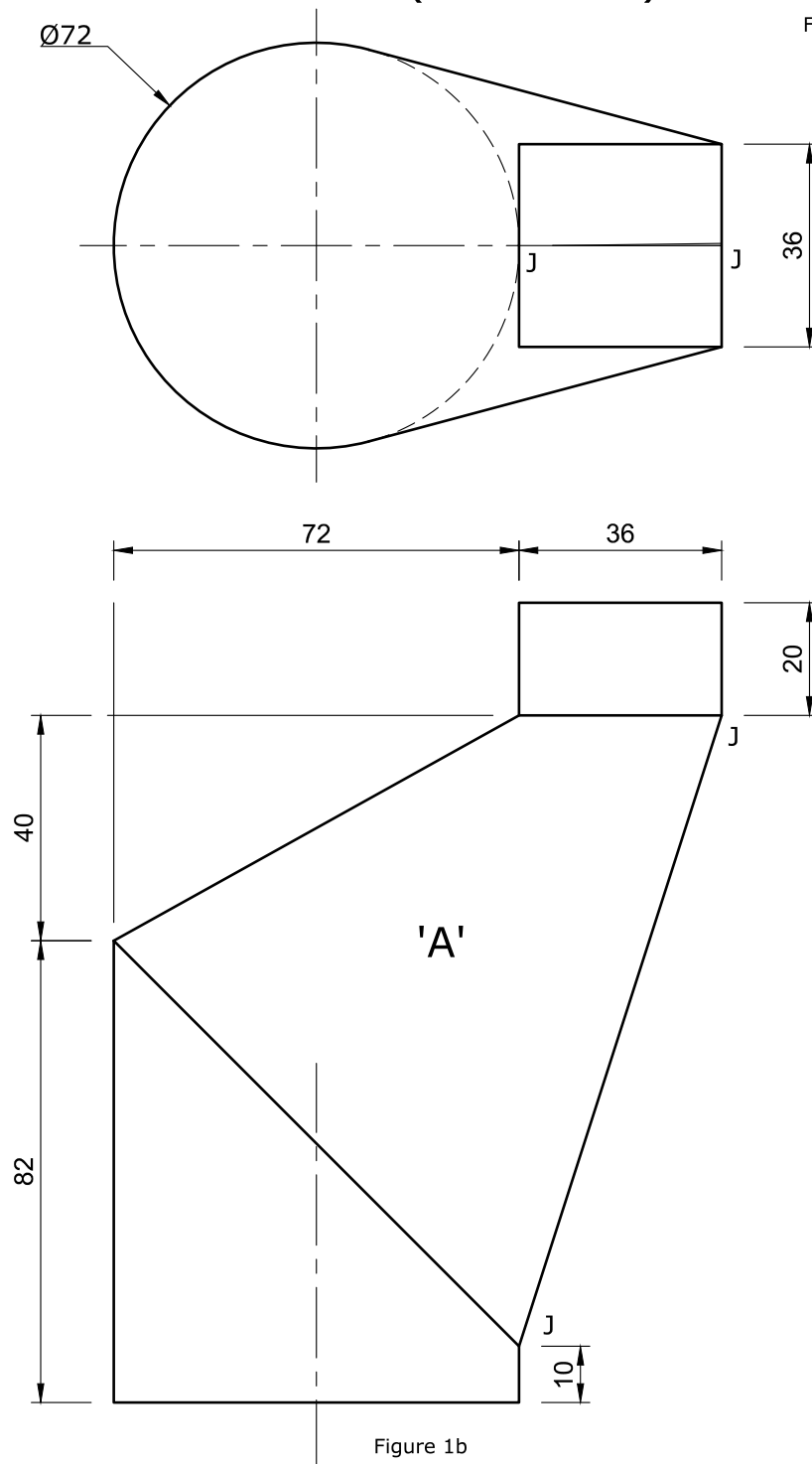
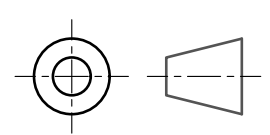

Figure 1b



Question 2.

Figure 2a shows a right cone intersected by an offset cylinder at an angle of 15° to the horizontal plane. Details of the intersected solids are given in the incomplete orthographic views in Figure 2b.

You are requested to:

- a. copy the given orthographic views; (2)
- b. project an auxiliary plan in order to plot the curve of intersection on the front elevation; (6)
- c. project the curve of intersection and complete the front elevation; (6)
- d. project the curve of intersection and complete the plan. (6)

Note: Show hidden details.

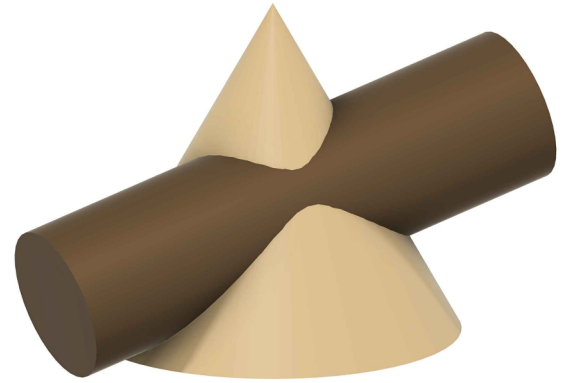

Figure 2a

(Total: 20 marks)

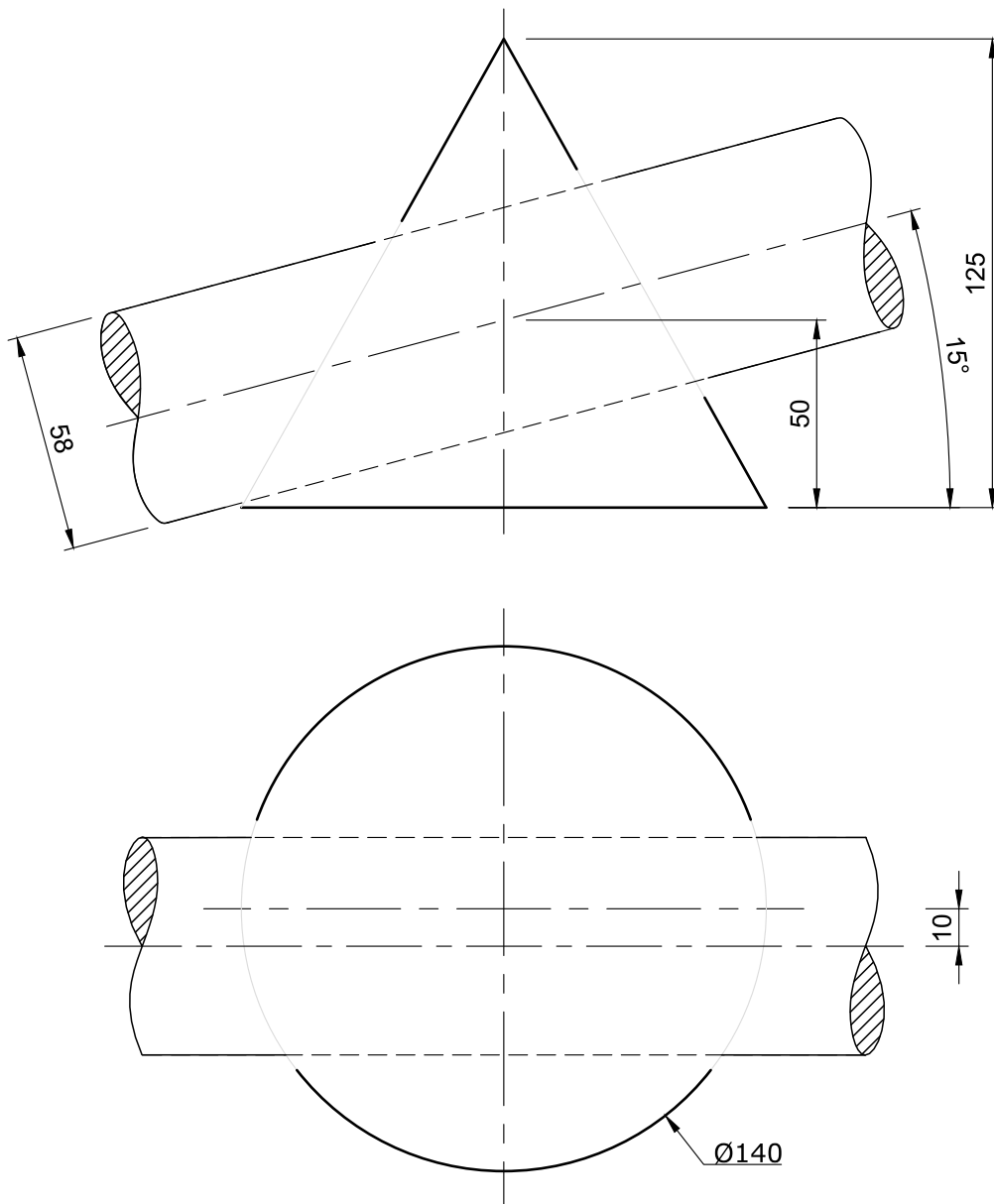
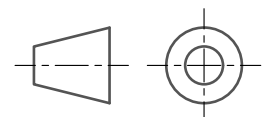

Figure 2b



Question 3.

An illustration of a wooden blocks arrangement is given in Figure 3a. Two dimensioned orthographic views of the arrangement are given in Figure 3b.

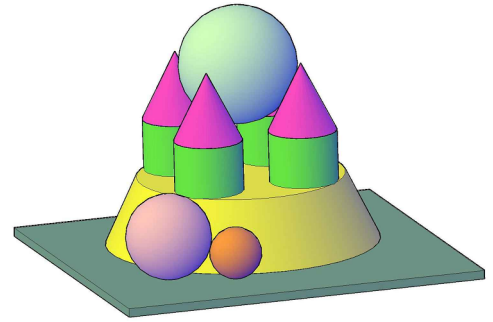

Figure 3a

- Four equispaced $\text{Ø}40$ mm cylinders with a conical cap are fixed on the top of a frustum of a right cone.
- Sphere **A**, of unknown diameter is resting tangentially between the four conical caps. The top of the sphere is to be 140 mm above the horizontal plane.
- Sphere **B**, also of unknown diameter, is resting on the horizontal plane and tangential to the frustum at point P.
- The smallest sphere **C** ($\text{Ø}30$ mm) is resting on the H.P. and is in mutual contact with sphere **B** and the frustum.

You are requested to:

- copy the given views; (2)
- determine, by construction, the diameter of sphere A, tangential with the four conical caps; (4)
- draw the sphere in position and state the diameter of sphere A; (1)
- determine, by construction, the diameter of sphere B; (2)
- draw sphere B in position and state its diameter; (2)
- draw, by construction, the $\text{Ø}30$ mm sphere C; (3)
- indicate the points of contacts in **all views**; (3)
- draw the hidden details and line in the visible details, in both views, with a bold outline. (3)

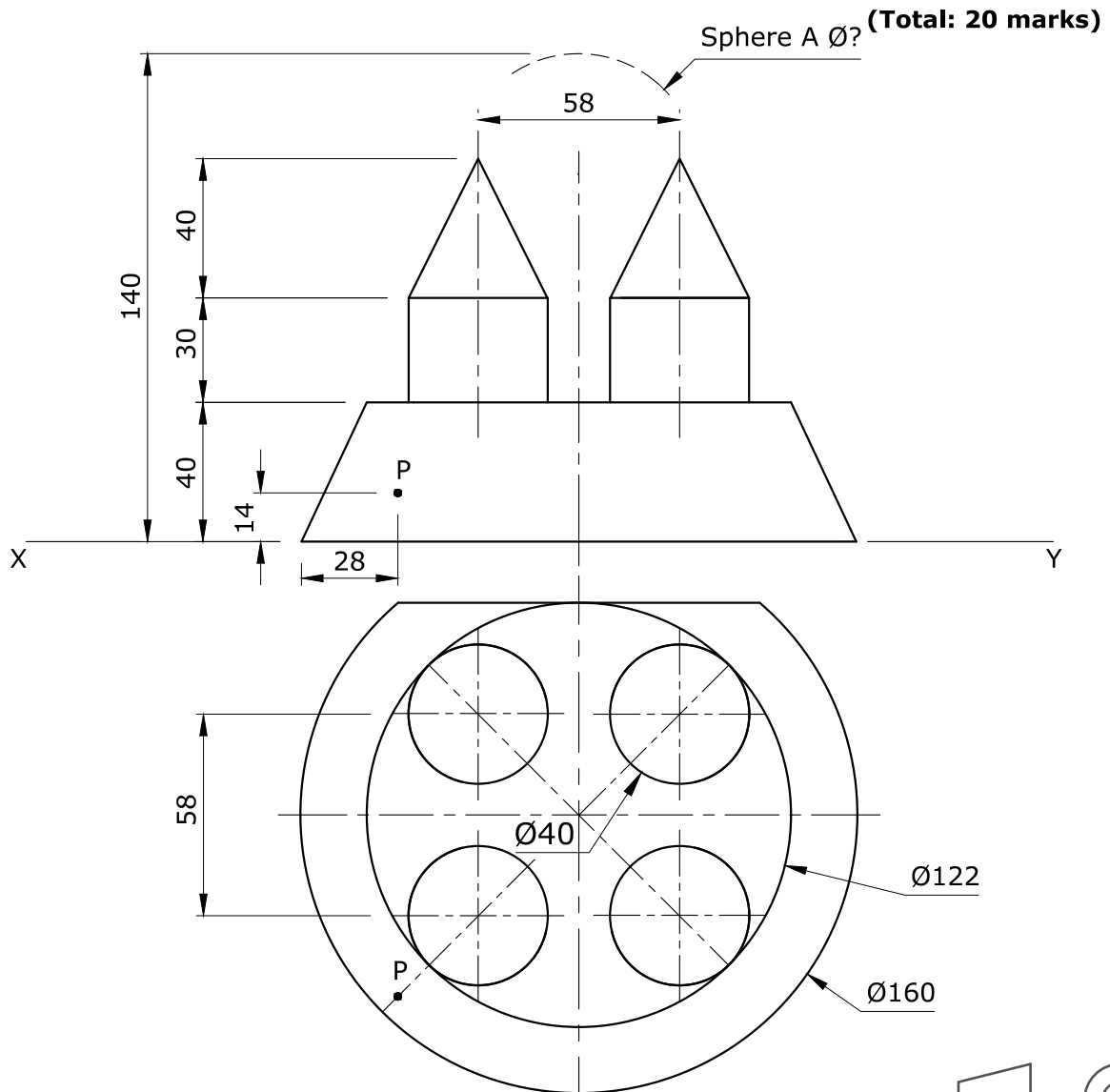

Figure 3b
Page 4 of 7

Question 4.

Figures 4a and 4b show two intersecting triangles ABC and DEF.

Using a scale of 1:1, you are requested to:

- copy the given views; (2)
- project an auxiliary elevation showing one of the triangles as an edge view to locate the points of intersection; (4)
- project the points of intersection to complete the plan and front elevation of the two triangles; (4)
- project an auxiliary view of the two triangles showing the line of intersection as true length; (3)
- project a second auxiliary view showing the two triangles as two intersecting lines and state the dihedral angle between them; (3)
- project the true shape of both triangles. (4)

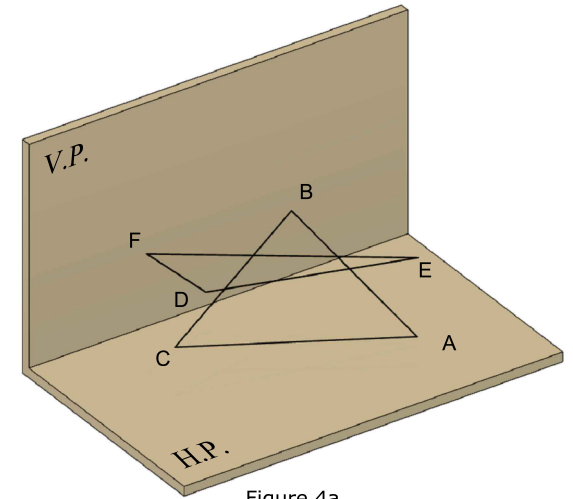

Figure 4a

(Total: 20 marks)

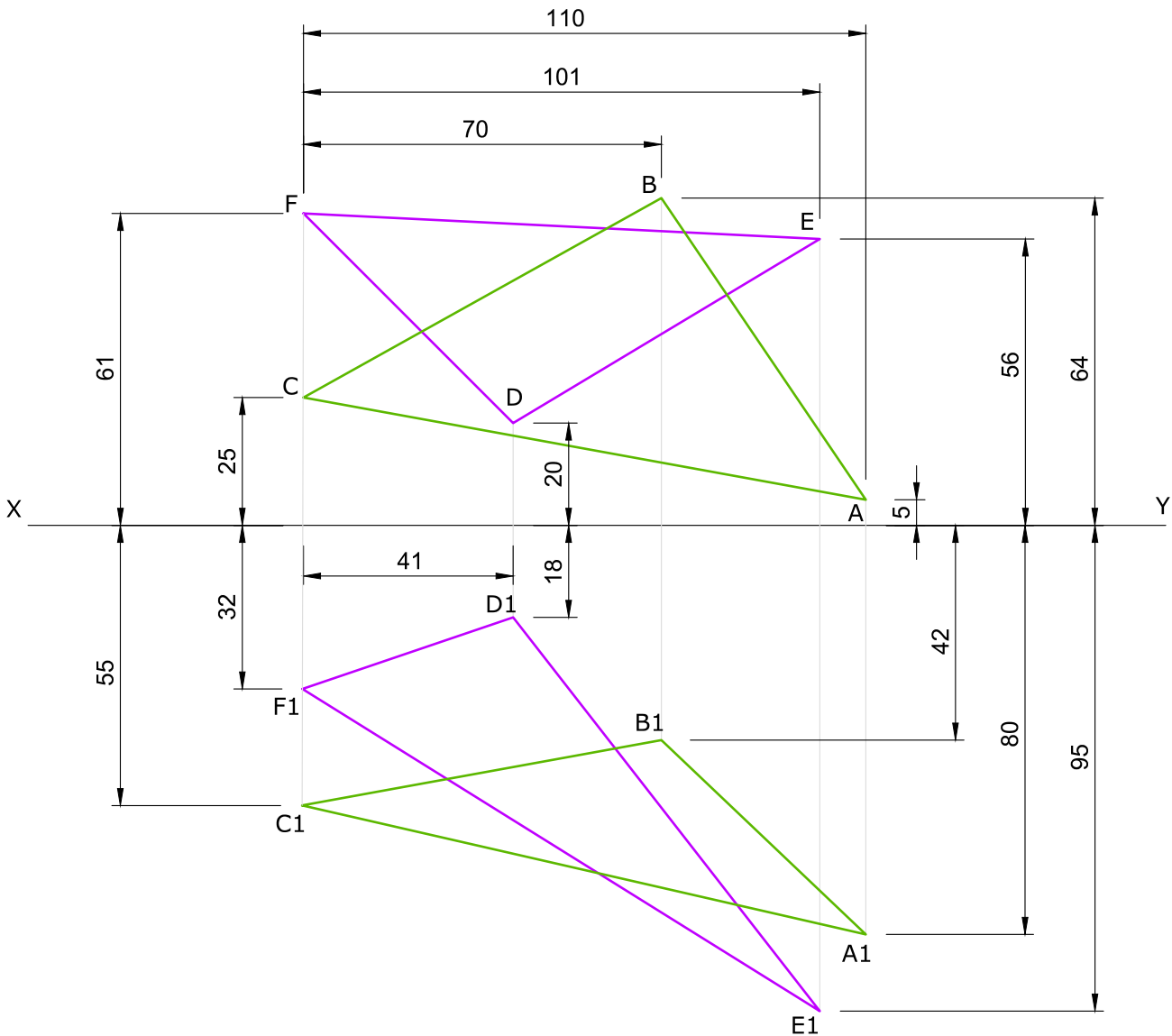
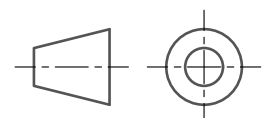

Figure 4b



Question 5.

Figure 5 describes a beam consisting of two parts which are hinged together. The hinged beam rests on three simple supports. You are requested to:

- a. draw Figure 5 and; (1)
- b. determine graphically:
 - i. the bending moment diagram; (6)
 - ii. the values of R_L , R_M and R_R ; (3)
 - iii. the magnitude, nature and position of the greatest bending moment; (3)
 - iv. the positions along the beam where the bending moment is zero; (1)
 - v. the shear force diagram; (5)
 - vi. the magnitude of the shear force at the hinge. (1)

Notes:

- Space diagram scale: 10 mm = 1 m
- Vector diagram scale : 1 mm = 1 kN

(Total: 20 marks)

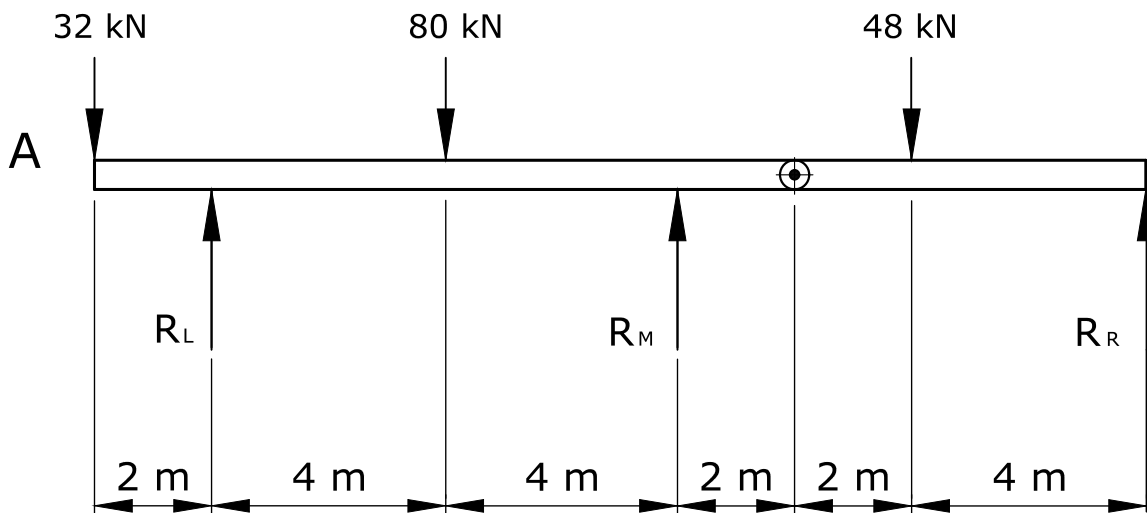

Figure 5

Question 6.

The traces VTH of an oblique plane are given in Figure 6c. Point O, shown in the plan, is the centre of the base of a cylinder $\text{Ø}80 \text{ mm}$ and 40 mm high. The cylinder is resting on the oblique plane as shown in Figure 6b.

A hexagonal pyramid, 80 mm across the corners and having a perpendicular height of 40 mm is mounted on the cylinder as shown in Figure 6a. The orientation of the pyramid is such that, in the front elevation, the flat side of the pyramid base is parallel to the horizontal plane.

You are requested to:

- a. copy full size Figure 6c; (2)
- b. convert the oblique plane to an inclined plane by projecting an auxiliary elevation; (2)
- c. state the inclination of the oblique plane to the horizontal plane; (1)
- d. project point O onto the inclined plane and construct the combined cylindrical and pyramidal solid; (5)
- e. draw the plan view of the combined solid; (5)
- f. project the front elevation. (5)

Note: Show hidden details.

(Total: 20 marks)

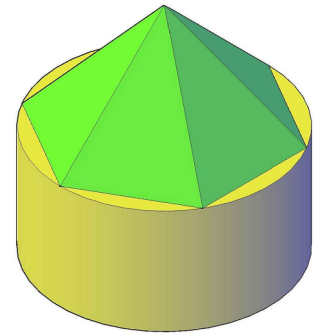

Figure 6a

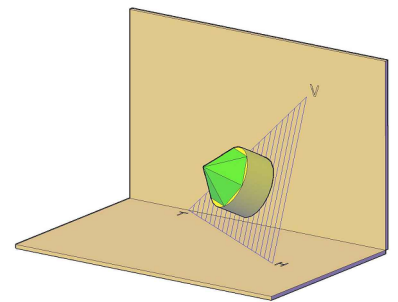

Figure 6b

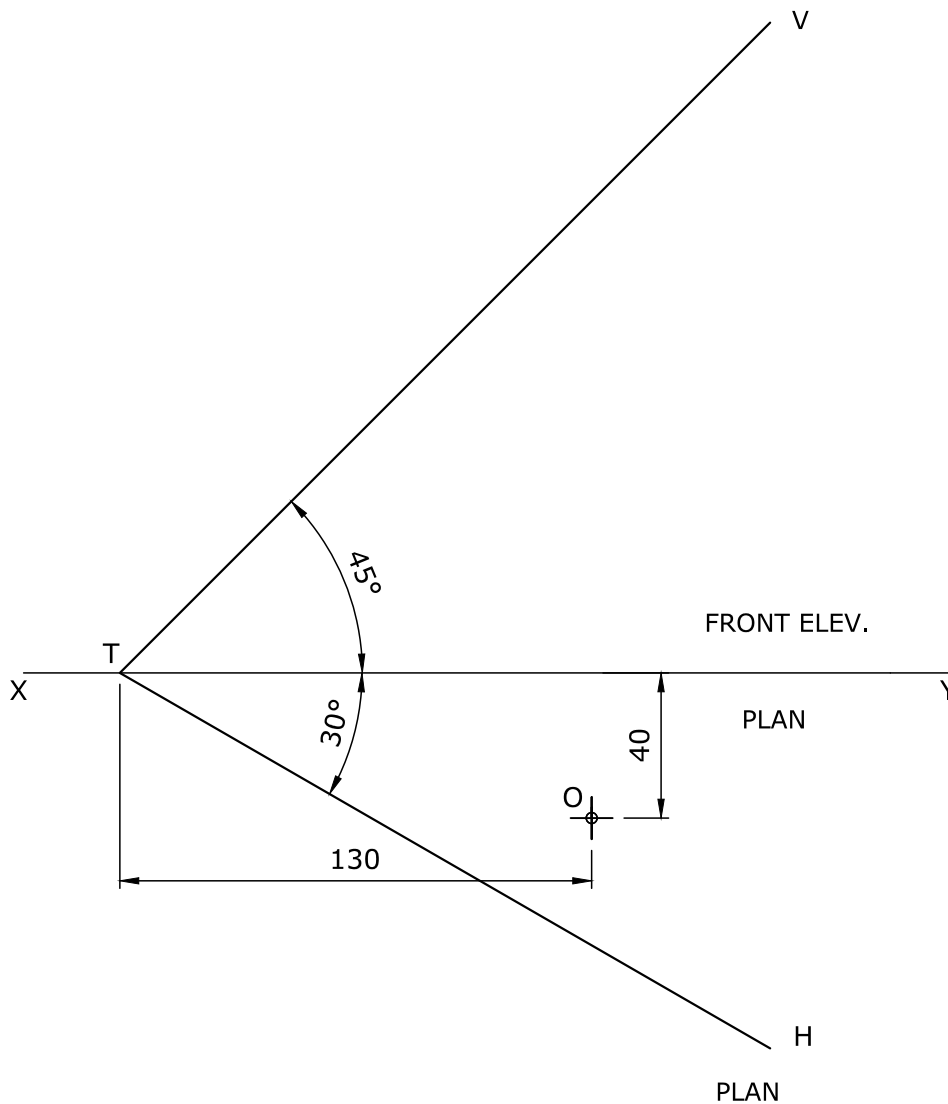
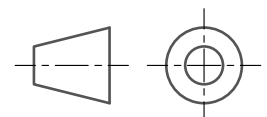

Figure 6c





SUBJECT:	Graphical Communication
PAPER NUMBER:	II
DATE:	8 th June 2023
TIME:	4:00 p.m. to 7:05 p.m.

Directions to Candidates

Write your index number where indicated at the top of all drawing sheets.

Attempt all **FOUR** questions.

Programmable calculators **cannot** be used.

Unless otherwise stated:

- drawings should conform to B.S. or equivalent (ISO) standards;
- all dimensions are in millimetres;
- answers are to be accurately drawn with instruments;
- all construction lines must be left on each solution;
- drawing aids may be used.

Dimensions not given should be estimated.

Careful layout and presentation are important.

Marks will be awarded for accuracy, clarity and appropriateness of constructions.

Colour/shading should be used where appropriate.

Mark allocations are shown in brackets.

Question 1 carries 34 marks. Questions 2, 3, and 4 carry 22 marks **each**.

Question 1.

Figure 1a shows three orthographic views of a meditation hall. These orthographic views show the proportion of every element within the building. Use this information to draw a two-point estimated perspective of this hall. The arrows on the plan indicate the viewing direction.

- a) Using **THREE** preliminary sketches, explore alternative positions of the horizon line and identify the one which, in your opinion, best describes the spaciousness of the entire area. (3)
- b) Based on the choice made in part (a), use a suitable scale to produce the required illustration on a single side of an A2 size paper, making the best use of the space available. (26)
- c) Enhance your drawing by colouring small areas of the different items appearing in your illustration. (5)

Notes:

- The stepped structure and raised platform are made of marble.
- The benches are made of timber.
- The window behind the raised platform and the side windows are made of stained glass.
- The carpet is made of durable stain-resistant fabric.
- An isometric view of one of the benches is shown in Figure 1b.

(Total: 34 marks)

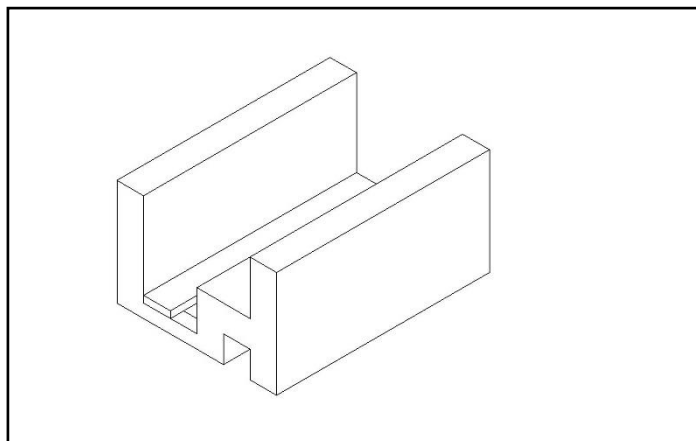
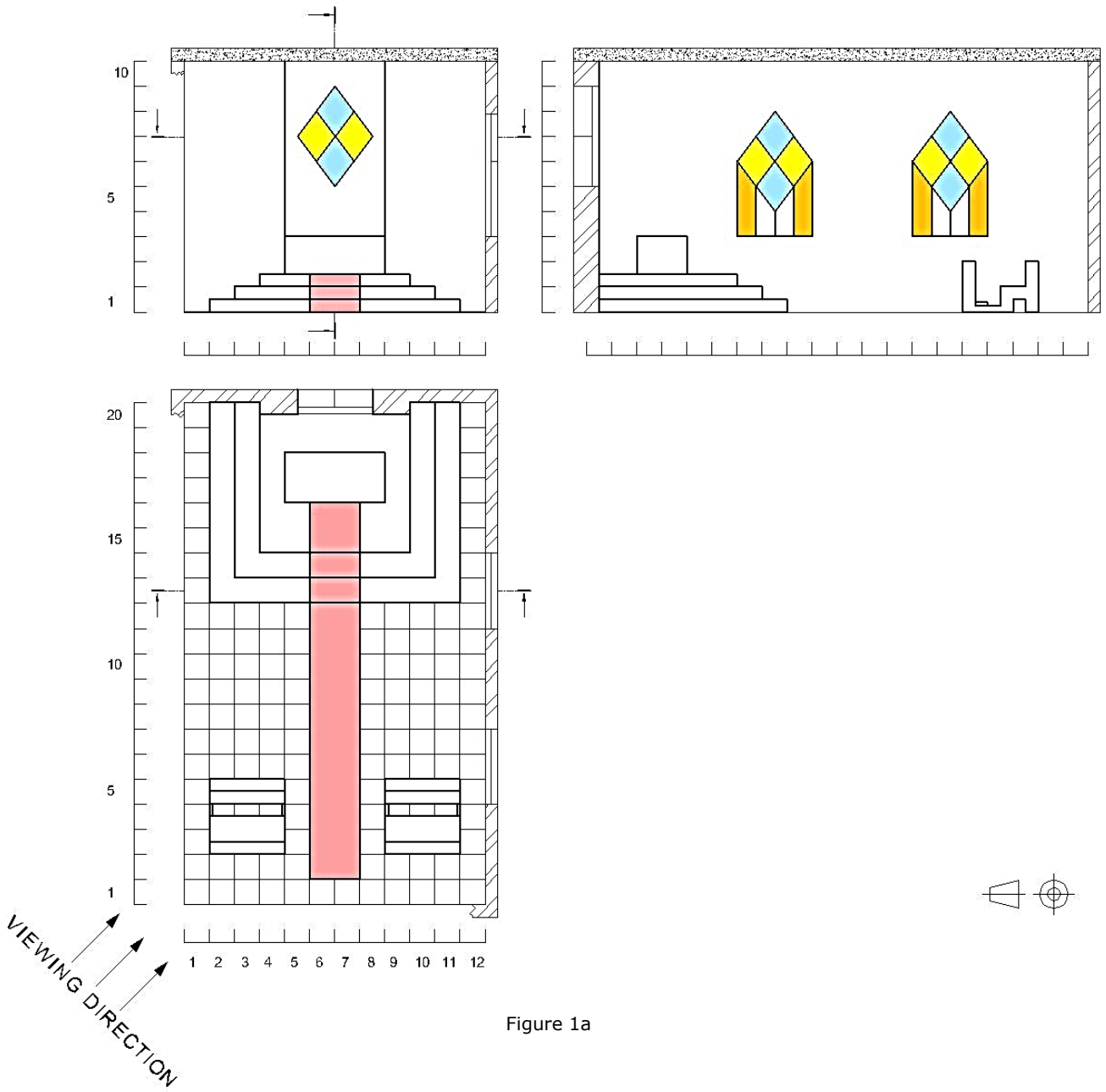

Figure 1b

Please turn the page.

Question 2.

A study on the agricultural sector has provided the following data, which is being presented in the following tables.

Table 1 - Income

Year	Rounded income in euros (Millions)
2017	53
2018	73
2019	75
2020	68
2021	64

Table 2 - Output in 2021





Type	Percentage share output
Crop products	40%
Livestock products	30%
Animal products	25%
Other products	5%

Table 3 - Expenses in 2021

Type	Percentage of total expenditure
Crop cultivation	10%
Energy and fuels	15%
Livestock feeding	50%
Other expenses	25%

The sections of livestock and animal products are categorized in the table 4 below:

Table 4

	Beef	Pork	Poultry	Rabbits
Livestock products				
	Milk	Cheese	Yoghurt	Eggs
Animal products				

- a) You are required to draw an infographic poster displaying the information in tables 1-3. The poster should contain appropriate text and graphs. The title of this poster should be 'AGRICULTURAL SECTOR STUDY'. Use suitable typefaces to show **all** written information. (12)
- b) In a separate section within the same A2 sheet, provide preparatory sketches and final versions for the missing icons in table 4. (10)

(Total: 22 marks)

Question 3.

Figure 2a shows the profile of a honey jar produced by a company with the name of GRANDMA'S HONEY. The company needs a new label design to appear on its honey jars.

You are being commissioned to design this label, which needs to include the name of the company and suitable graphics associated with the product.

You need to present your work broken down according to the following steps and as shown in Figure 2b below.



Figure 2a

- a) Written analysis
Identify, using keywords/short phrases, the main parameters of the design brief. (2)
- b) Graphical analysis
Based on your response to the written analysis, produce a series of preparatory sketches that illustrate your developing ideas. (4)
- c) Design synthesis
Clearly identify those elements present in your sketches that you intend to use in your final design. (2)
- d) Final realisation
Use colour and shading to produce your final realisation in a hexagon as shown in Figure 2b. (14)

Notes:

- Use suitable typefaces for your design.
- Details of the page layout and the design space are given in Figure 2b below.

(Total: 22 marks)

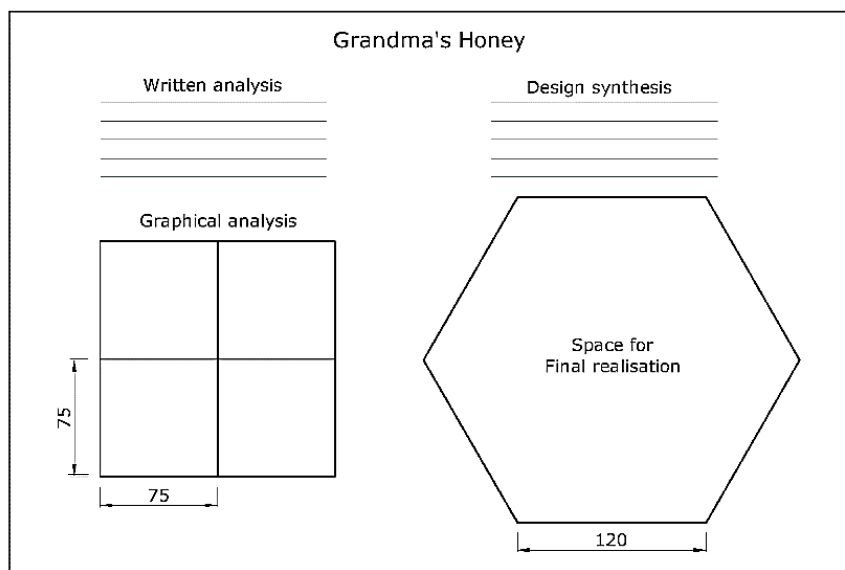

Figure 2b

Question 4.

Figure 3 shows four orthographic views of a food mixer.

You are requested to:

- a) make a well-proportioned pictorial (3D) freehand drawing of this appliance; (14)
- b) colour and shade your drawing using the following instructions: (8)
 - main body – aluminium (silver colour);
 - upper cover on main body – durable ABS (plastic) (red);
 - planetary action and whisk – cast stainless steel (grey);
 - mixing bowl – coloured and polished stainless steel (yellow).

Note: Place the mixing bowl at the foreground of your drawing.

(Total: 22 marks)



Figure 3