



SUBJECT:	Physics
PAPER NUMBER:	I
DATE:	26 th June 2021
TIME:	9:00 a.m. to 12:05 p.m.

A list of useful formulae and equations is provided. Take the acceleration due to gravity $g = 9.81 \text{ m s}^{-2}$ unless otherwise stated.

SECTION A

Attempt all EIGHT questions in this section. This section carries 50% of the total marks for this paper.

- The power P emitted by a blackbody at a temperature T , in Kelvin, satisfies the proportionality relation $P \propto T^4$.
 - Distinguish between a base unit and a derived unit. (2)
 - Determine the base SI units of the proportionality constant. (4)
 - Estimate the magnitude of the proportionality constant in terms of its base units if the Sun's blackbody temperature is $5530 \text{ }^\circ\text{C}$ and its average emitted power is $3.9 \times 10^{26} \text{ W}$. (2)
 - Give **TWO** possible reasons why a scientific relation may be incorrect even though it is homogeneously correct. (2)

(Total: 10 marks)

- A 220 kg piano is lowered from a house by the use of a crane. The piano is placed on a 20 kg platform which is suspended by a cable as shown in Figure 1.

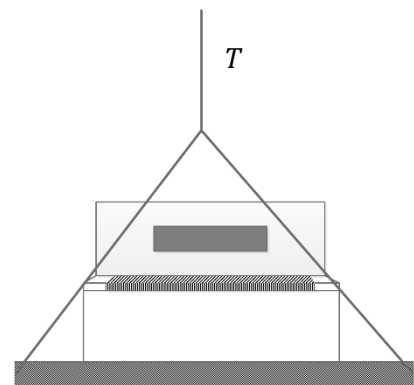

Figure 1

- Initially, the piano is lowered at a constant acceleration of 0.3 m s^{-2} . Determine the tension T in the cable. (3)
 - Later, the piano is lowered at a constant speed of 0.1 m s^{-1} . Would the piano experience weightlessness in this case? Explain your reasoning. (4)
 - The cable suddenly snaps. Does the piano experience weightlessness? Explain. (3)
- (Total: 10 marks)**
- In chair swing rides, people sit in a chair attached to one end of a cable while the other end is attached to a horizontal bar that can rotate in a circular motion. The angular speed ω of the bar is determined by the central vertical rotating frame. Due to the rotation, the chairs start to bank at some angle θ as shown in Figure 2.

- a. At which position (*A* or *B*) would the passenger experience the largest tangential speed? Explain your reasoning. (3)
 - b. Show that the banking angle obeys the relation $\tan \theta = \frac{r\omega^2}{g}$ where r is the distance from the chair to the central frame. (3)
 - c. Hence, would the banking angles of chairs in positions *A* and *B* be the same or different? Explain your reasoning. (4)
- (Total: 10 marks)**

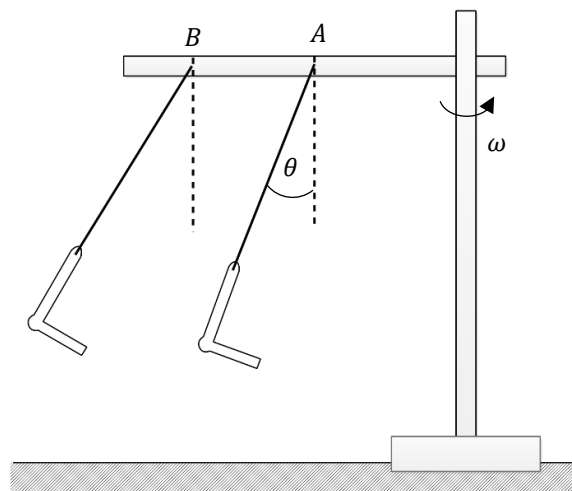

Figure 2

- 4. A 1 kg flowerpot is hung at the end of a hinged 50 cm uniform beam of mass 2.5 kg by a short string as shown in Figure 3. The beam is suspended by a rope attached to the wall at an angle of 40° to the vertical.
 - a. What is the tension in the string? (1)
 - b. Determine the tension in the rope. (3)
 - c. Hence, determine the reaction force at the hinge. (4)
 - d. Is the rope more likely to break if the flowerpot is hung closer to the hinge? Explain your reasoning. (2)

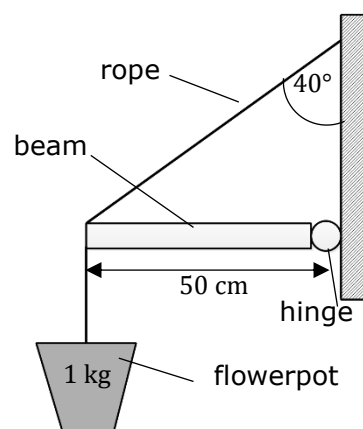

Figure 3

(Total: 10 marks)

- 5. Consider the circuit illustrated in Figure 4. Assume that the lamp has a constant resistance of 10 Ω.
 - a. Briefly describe the function of an LDR highlighting its variation with resistance. (1)
 - b. Show that the voltage across the bulb can be expressed by $V_{bulb} = 9 \left(\frac{5}{5+R} \right)$, where R is the resistance of the LDR. (4)
 - c. Hence, describe how the brightness of the bulb changes when the:
 - i. LDR is shielded from light; (2)
 - ii. LDR is exposed to light. (2)

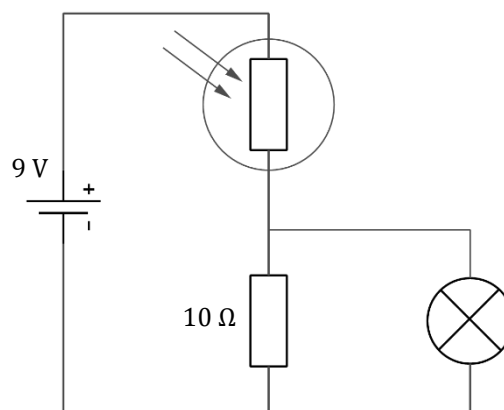

Figure 4

- d. Would the circuit be suitable for an outdoor lamp light that switches on at dusk? Explain. (1)

(Total: 10 marks)

6. A 1 m long wire of resistivity ρ is composed of two distinct sections A and B having radii r_A and r_B respectively. When a current I flows through the wire, the relationship between the electron's drift velocity and the wire's length is shown in Figure 5.

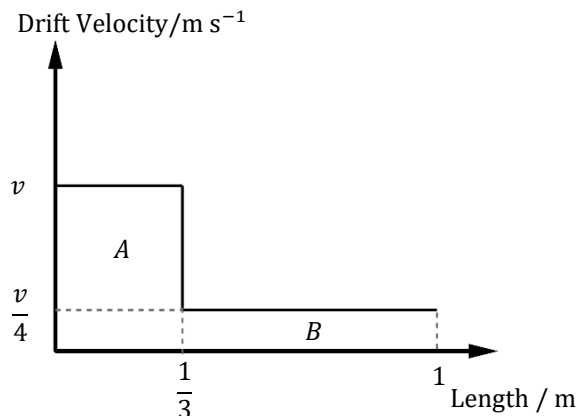

Figure 5

a. Show that $r_B = 2r_A$. (3)

b. Hence, show that the whole wire's resistance is given by $R = \frac{\rho}{2\pi r_A^2}$. (5)

c. Assuming the current remains unchanged, what happens to magnitude of the drift velocity in **each** section if:

- i. the cross-sectional area of each section is doubled? (1)
- ii. the length of each section is doubled? (1)

(Total: 10 marks)

7. In the circuit shown in Figure 6, a number of identical batteries having e.m.f. 6 V and internal resistance 0.05Ω are connected to an external resistor of resistance R .

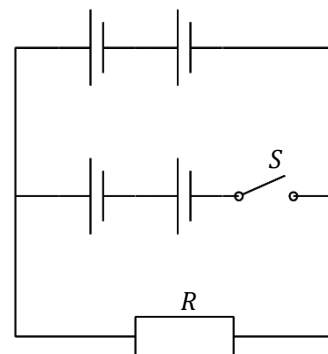

Figure 6

a. Obtain, in terms of R , an expression for the current flowing through the resistor when:

- i. the switch S is open; (3)
- ii. the switch S is closed. (3)

b. Hence, write down the ratio of the current flow when the switch is open to when the switch is closed. (2)

c. State how the ratio in part (b) changes when the resistance R :

- i. is zero; (1)
- ii. is a very large value. (1)

(Total: 10 marks)

8. The four lowest energy levels of a hydrogen atom are -13.6 eV , -3.4 eV , -1.51 eV and -0.85 eV . An electron transitions from the -1.51 eV to the -3.4 eV energy level resulting in an emitted photon.

a. Define what is meant by ionising energy and obtain its value for an electron situated in the ground state. Give your answer in Joules. (2)

b. Sketch an energy level diagram representing the hydrogen's energy levels and the electron transition. (3)

c. Determine the wavelength of the emitted photon. (3)

d. Give **ONE** example of another possible transition which emits a photon with a shorter wavelength than that obtained in part (c). (2)

(Total: 10 marks)

Please turn the page.

SECTION B

Attempt any FOUR questions from this section. Each question carries 20 marks. This section carries 50% of the total marks for this paper.

- 9.
- a. Define the terms proportionality limit and elastic limit for an elastic material. (2)
 - b. On **TWO** separate graphs, sketch a stress-strain graph for a ductile and a brittle material. On **each** graph, clearly indicate the points representing the proportionality limit, elastic limit and breaking point. (2, 2)
 - c. A 250 g ball is dropped vertically onto a light cardboard plane sheet of negligible mass that can slide vertically onto a system of springs, as shown in Figure 7.

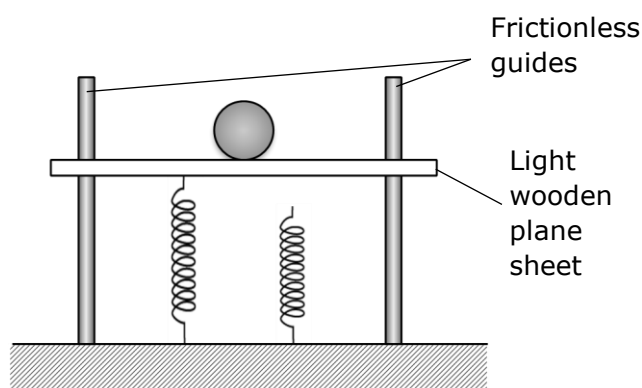

Figure 7

Initially, both springs are uncompressed. The first spring starts to compress as soon as the ball hits the cardboard sheet. After a compression of 10 cm, the second spring begins to be compressed. The ball momentarily stops after a total compression distance of 15 cm. A graph representing the force F experienced by the combined spring system against compression x is shown in Figure 8.

- i. Use the graph to determine the spring constant of the first spring. (2)
- ii. Hence, use the graph to determine the spring constant of the second spring. (3)
- iii. Obtain the value of the gradient between the 10 cm and 15 cm compression and discuss its significance. (3)
- iv. What does the area under the graph represent? Obtain its value. (3)
- v. Hence, or otherwise, determine the initial height above the top of the first spring from where the ball has been dropped from. (3)

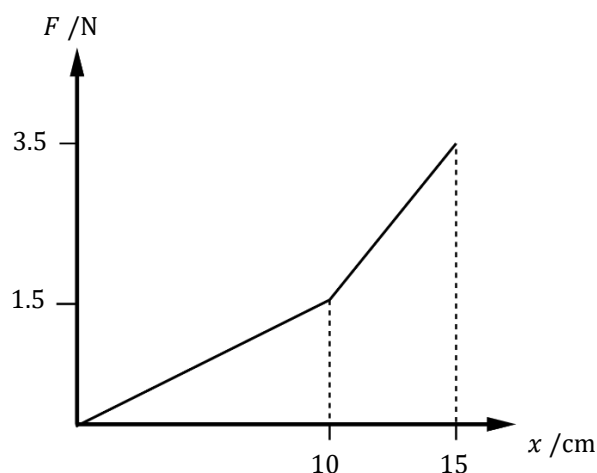

Figure 8

(Total: 20 marks)

10. Pure silicon is an example of an intrinsic semiconductor having four outer valence electrons. To alter its electrical conductivity properties, some of the silicon atoms were replaced by a pentavalent phosphorus atom.

- What is this process called? Explain how this process influences the conductivity of semiconductors. (1, 2)
- Sketch the resulting silicon-phosphorus crystalline structure clearly indicating any valence electrons and holes. (2)
- Is the resulting material a p-type or an n-type semiconductor? Explain your reasoning. (1)
- Describe how the population of holes and electrons is different in both semiconductor types. (1, 1)
- Sketch a detailed, well labelled band diagram for a conductor, p-type and n-type semiconductors. (2, 2, 2)
- Using the sketched band diagrams from part (e), describe how electrical conduction takes place in conductors, p-type and n-type semiconductors once an electric field is applied. Your description should include whether conduction takes place mostly by the electrons or by the holes. (2, 2, 2)

(Total: 20 marks)

11. A uniform fridge door is attached to two hinges so that it can be opened or closed. The door has a width of 50 cm and a height of 100 cm and weighs 13 kg whereas the hinges are separated by a distance of 60 cm, from their mid-points as shown in Figure 9.

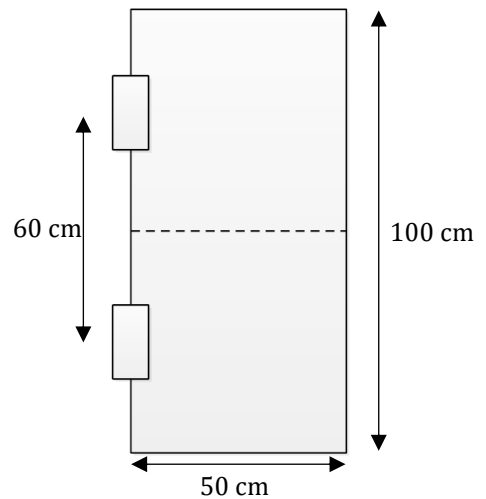

Figure 9

- State the **TWO** conditions required for a system to be in static equilibrium. (2)
- Explain what is meant by centre of gravity and identify its acting location on the door. (2, 1)
- State, giving reasons, which one of the figures (a), (b) or (c) in Figure 10 correctly describes the directions of the reaction forces felt at the hinges. Explaining also why the other options are incorrect. (5)

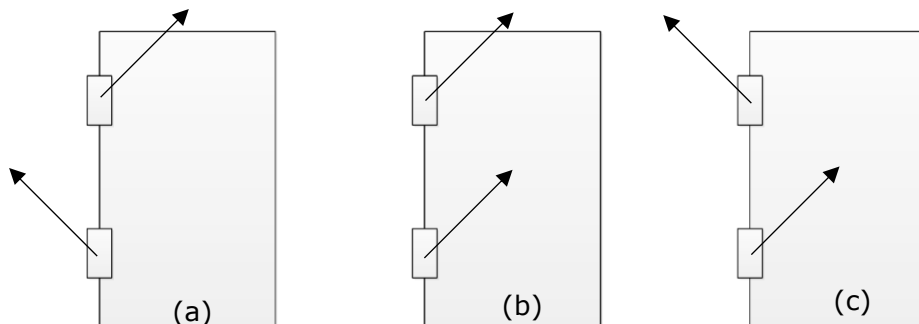

Figure 10

Please turn the page.

- d. Hence, determine the magnitudes of **each** reaction force. (6)
- e. Would a larger separation between the hinges be more beneficial to support the door? Explain your reasoning. (2)
- f. Another design consists of having three equally spaced hinges installed as opposed to just two. Explain why this would make the structure sturdier. (2)

(Total: 20 marks)

12.

- a. A spring of spring constant 25 N m^{-1} is compressed 5 cm by a 0.2 kg block. Once released, the block follows an initial horizontal path, followed by a circular path of radius 20 cm onto another horizontal section until it hits another spring of spring constant 30 N m^{-1} . The setup is shown in Figure 11. Assume that the surfaces are smooth.
 - i. Determine the block's speed once it is released from the spring. (3)
 - ii. Show that the block will lose contact along the circular path at some height h when the block's speed satisfies $v = \sqrt{gh}$. (5)
 - iii. Hence, determine this height. (4)
 - iv. Assuming no energy is lost once the block hits the ground, determine the maximum compression in the second spring. (4)



Figure 11

- b. A fraction of the kinetic energy of an amount of water which flows through a hydroelectric dam is converted into electrical energy. Each hour, 40,000 kg of water falls a height of 200 m and the outputted electrical power is 15,260 W. Determine the efficiency of the power plant. (4)

(Total: 20 marks)

13. Figure 12 is a circuit which can be used to determine the diameter of thin wires. It consists of a $100\ \Omega$ resistor, a variable resistor R , a reference wire X and a test wire Y , all connected to a battery of e.m.f. ε and an ideal ammeter. The reference and test wires have the same resistivity ρ , same length L but have different radii of cross-section $r_X = 2\ \text{mm}$ and r_Y respectively.

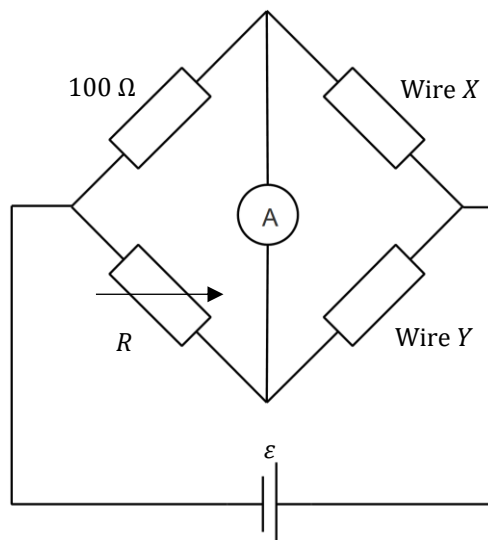

Figure 12

- a. State Kirchhoff's laws and state how **each** law satisfies a conservation law. (2, 2)
- b. Using Kirchhoff's laws, show that the ammeter registers a zero current when $\frac{100}{R} = \frac{R_X}{R_Y}$ where R_X and R_Y are the resistances of wires X and Y respectively. (4)
- c. Hence, determine the radius of wire Y if a zero current is read when $R = 250\ \Omega$. (3)
- d. Does the condition obtained in part (b) change if the ammeter is replaced by a non-ideal one? Explain your reasoning. (2)
- e. If the supply e.m.f. was doubled, would the condition obtained in part (b) change? Explain your reasoning. (1)
- f. If the ammeter were to be replaced by an ideal voltmeter, what is its reading when the condition obtained in part (b) is reached? (1)
- g. The test wire Y is replaced by another test wire Z having the same radius and length as the reference wire X but with twice the conductivity.
 - i. Define what is meant by conductivity and how it is related to the resistivity of a material. (2)
 - ii. What value of R is required to make the ammeter read a zero current? (3)

(Total: 20 marks)

14. An isotope of copper ${}^{64}_{29}\text{Cu}$ can undergo two forms of radioactive decay:

Reaction A	${}^{64}_{29}\text{Cu} \rightarrow {}^{64}_{28}\text{Ni} + {}^0_1\beta^+ + \nu$
Reaction B	${}^{64}_{29}\text{Cu} \rightarrow {}^{64}_{30}\text{Zn} + {}^0_{-1}\beta^- + \bar{\nu}$

The rest masses of ${}^{64}_{29}\text{Cu}$, a proton and a neutron are $63.9298\ \text{u}$, $1.0073\ \text{u}$ and $1.0087\ \text{u}$ respectively.

- a. What are the particles denoted by ν and $\bar{\nu}$? (1)
- b. Identify the nature of the reactions A and B , and describe in detail what happens during **each** reaction. (2, 2)
- c. Determine the rest mass of ${}^{64}_{30}\text{Zn}$ atom in terms of the a.m.u if the ${}^0_{-1}\beta^-$ particle is ejected with a maximum kinetic energy of $0.5787\ \text{MeV}$. Neglect the mass of the $\bar{\nu}$ particle. (3)

Question continues on next page.

- d. Define the terms binding energy and binding energy per nucleon. (2)
- e. Determine the binding energy per nucleon of the ${}_{29}^{64}\text{Cu}$ atom in MeV. (3)
- f. Sketch the binding energy per nucleon against atomic number and explain how it can be used to identify the stability of an atom. (2, 1)
- g. Use your sketch in part (f) to distinguish between nuclear fission and nuclear fusion by making reference to the stability of the nucleus. (2, 2)

(Total: 20 marks)

15. An 8 kg bowling ball is swung and let go from a height of 0.6 m with a horizontal velocity of 0.5 m s^{-1} such that it lands onto the start of an 18 m long bowling lane surface. The bowling ball is taken to be a sphere of radius 10 cm and has moment of inertia equal to 0.032 kg m^2 . Once the ball hits the surface, it experiences a constant 1.2 N frictional force. Initially, the bowling ball slides along the lane for 5.7 m and then starts to experience pure rolling.

- a. Determine the initial linear velocity of the bowling ball just as it makes contact with the ground. (2)
- b. Determine the deceleration experienced by the bowling ball during sliding. (2)
- c. Hence, determine the final velocity just before the bowling ball experiences pure rolling. (2)
- d. What is the time taken to travel the 5.7 m distance? (2)
- e. Once the ball starts to experience pure rolling, determine the angular acceleration of the bowling ball. (3)
- f. Hence, determine the total time taken for the bowling ball to travel the whole bowling lane. (6)
- g. Describe **ONE** simple method which can help reduce the total time for the bowling ball to travel the whole bowling lane. (1)
- h. If another bowling ball with a smaller moment of inertia is used, would it take a shorter, the same or a longer amount time than that calculated in part (f)? Explain your reasoning. (2)

(Total: 20 marks)



SUBJECT:	Physics
PAPER NUMBER:	II
DATE:	26 th June 2021
TIME:	4:00 p.m. to 7:05 p.m.

A list of useful formulae and equations is provided. Take the acceleration due to gravity $g = 9.81 \text{ m s}^{-2}$ unless otherwise stated.

SECTION A

Attempt all EIGHT questions in this section. This section carries 50% of the total marks) for this paper.

- A student incorrectly defines temperature as being a measure of the heat inside a body.
 - Explain why the above definition of temperature is incorrect. Your answer should include the phrases 'thermal equilibrium' and 'internal energy'. (4)
 - Apply the first law of thermodynamics to the following situations:
 - the heating of a filament lamp milliseconds after switching on; (3)
 - the same filament lamp under steady conditions. (3)

(Total: 10 marks)
- A piece of iron of mass $2.0 \times 10^{-3} \text{ kg}$, specific heat capacity $380 \text{ J kg}^{-1} \text{ K}^{-1}$ and a temperature of 290 K is dropped into liquid oxygen maintained at its boiling point of 90 K . The volume of oxygen driven off, measured at a temperature of 273.15 K and a pressure of $1.06 \times 10^5 \text{ Pa}$, is $8.14 \times 10^{-4} \text{ m}^3$. The density of oxygen at normal temperature (273.15 K) and pressure ($1.01 \times 10^5 \text{ Pa}$), also referred to as N.T.P, is 1.40 kg m^{-3} . Calculate:
 - the volume of oxygen driven off at normal temperature and pressure; (3)
 - the mass of oxygen driven off; (2)
 - the heat energy transferred from the iron to the liquid oxygen; (2)
 - the specific latent heat of vaporisation of liquid oxygen. (3)

(Total: 10 marks)
- Artificial satellites may be in a geostationary orbit.
 - What is a geostationary orbit, and what is its main advantage over other orbits? (2)
 - A satellite of mass m travels with speed v in a circular orbit at a height h above the surface of the Earth. If the mass of the Earth is M and its radius is R , write down an equation relating the centripetal force on the satellite to the gravitational force. (2)

- c. Hence show that the orbital period T of the satellite is given by $T^2 = \frac{4\pi^2(R+h)^3}{GM}$. (3)
- d. If the mass of the Earth is 6.00×10^{24} kg and its radius is 6.40×10^6 m, show that the period of a satellite cannot be less than 84.8 minutes. (3)

(Total: 10 marks)

4. Figure 1 shows two graphs of pressure P against volume V for a fixed mass of an ideal gas. The gas undergoes the two expansions shown in the diagram, starting under the same conditions of pressure, volume, and temperature.

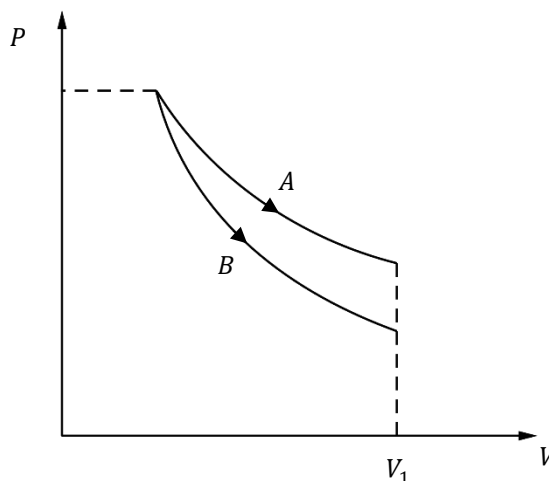

Figure 1

- a. One of the graphs shows an isothermal expansion while the other shows an adiabatic expansion. State which of the graphs, A or B , shows the adiabatic process. Explain fully your answer. (3)
- b. Briefly describe the process that needs to be carried out so that a fixed mass of gas enclosed in a cylinder fitted with a moveable piston can undergo:
- i. an approximately isothermal compression; (1)
 - ii. an approximately adiabatic expansion. (1)
- c. The two expansions end with the gas having the same volume V_1 . State the process in which the gas does the greater amount of work. Explain your answer. (3)
- d. What is the source of the energy which is converted to work in:
- i. the adiabatic expansion; (1)
 - ii. the isothermal expansion? (1)

(Total: 10 marks)

5. In an experiment to measure the thermal conductivity of a glass disc of thickness 2.0×10^{-3} m and 0.12 m diameter, the disc is inserted between two copper blocks of the same diameter as the disc, as shown in Figure 2. Steam at 373 K is passed through the hollow upper block, A , while a thermometer (not shown) reads the temperature of the solid lower block, B . When steady conditions are reached, the rate of heat loss to the atmosphere through the lower block is 285 W and its temperature is 310 K.

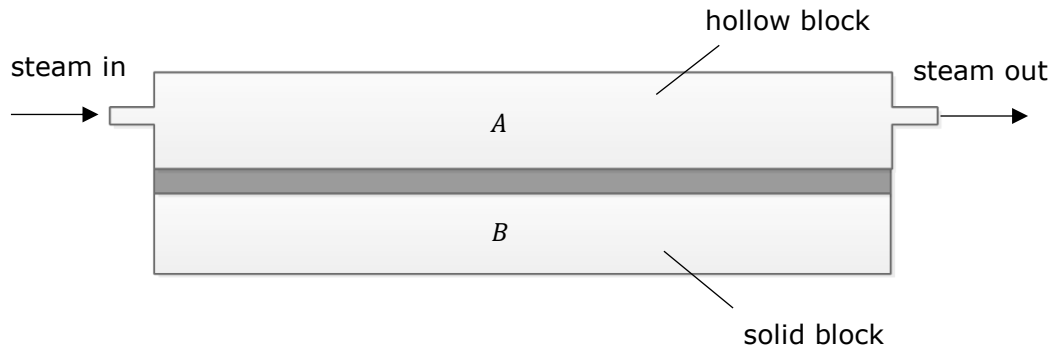

Figure 2

- a. A student suggests that the apparatus should be turned over so that block *A* is below the disc and block *B* is above in order to obtain a more reliable result for the thermal conductivity of the disc. Explain why this suggestion should **not** be followed. (2)
- b. The blocks are made of copper. Would you use the same apparatus to determine the thermal conductivity of a thin copper disc? Explain your answer. (2)
- c. Calculate the thermal conductivity of the glass disc. (4)
- d. What would be the main source of uncertainty in the experiment described above? (2)

(Total: 10 marks)

6. Domestic users are supplied with mains electricity at a root mean square voltage of 240 V at a frequency of 50 Hz.

- a. Explain what is meant by root mean square voltage. (2)
- b. Calculate the peak voltage supplied. (1)
- c. A capacitor of capacitance 20.0 μF is connected across the mains supply. Calculate:
 - i. the capacitive reactance of the capacitor; (2)
 - ii. the root mean square current in the circuit if the capacitor is replaced by one having half the capacitance. (2)
- d. Explain why no energy is dissipated in the capacitor. (2)
- e. Is energy dissipated if the capacitor is replaced by a pure inductor? (1)

(Total: 10 marks)

7. Two straight, very long conductors, *A* and *B*, carrying equal currents, *I*, in the same direction, run vertically into the plane of the paper, as shown in Figure 3.

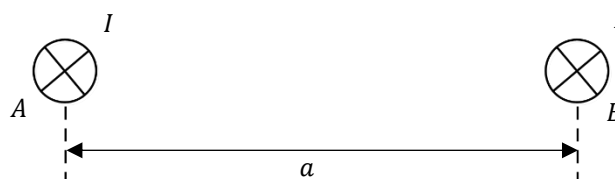

Figure 3

Question continues on next page.

- a. Copy the diagram and draw the magnetic flux pattern in the plane of the paper in the neighbourhood of the two conductors. (3)
- b. The distance between the two conductors is a m.
 - i. Write down an equation for the flux density at the position of conductor A due to the current in conductor B . (1)
 - ii. Hence obtain an equation for the force per unit length on **each** conductor. (2)
 - iii. Draw the direction of these forces on the diagram drawn in part (a). (1)
- c. Define the ampere. (1)
- d. The flux pattern drawn in part (a) assumes that the magnetic field of the Earth has no effect on the pattern. Under which condition will the Earth's field affect the pattern considerably? (2)

(Total: 10 marks)

8. Red light from a laser is passed through a narrow slit, S , as shown in Figure 4. A pattern of bright and dark regions is observed on a screen placed 3.0 m away from the slit.

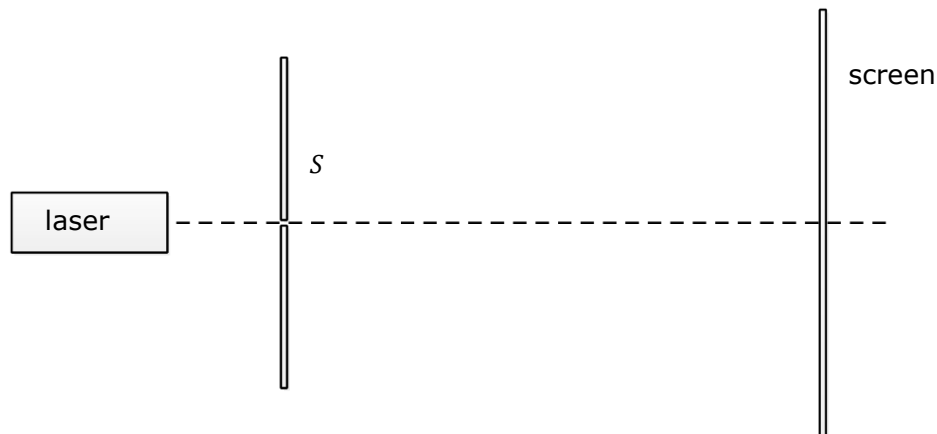

Figure 4

- a. Sketch a graph to show how the light intensity on the screen varies with distance from the centre of the diffraction pattern. (2)
- b. With the use of an appropriate equation, describe how the graph drawn in part (a) would change if a shorter wavelength of light is used. (3)
- c. Write down approximate values for slit width when diffraction patterns produced by:
 - i. visible light; (1)
 - ii. 3 cm microwaves (1)
 are to be demonstrated.
- d. How would you detect the pattern produced by microwaves? (2)
- e. Sketch a diagram to show the diffraction pattern produced if the slit is replaced by a small hole in a metal sheet. (1)

(Total: 10 marks)

SECTION B

Attempt any **FOUR** questions from this section. Each question carries **20** marks. This section carries **50%** of the total marks for this paper.

9. The kinetic theory of gases is based on a number of assumptions among which there are the following:

- the total volume of the molecules of a gas is very much smaller than the volume containing the gas;
- the molecules of a gas are in continual random motion.

a. Describe the experimental evidence behind these two assumptions. (4)

b. For N particles, each of mass m , of an ideal gas, the kinetic theory shows that:

$$PV = \frac{1}{3}Nm\langle c^2 \rangle$$

i. Explain the meaning of the mean square speed $\langle c^2 \rangle$. (2)

ii. Write down an expression for the total kinetic energy of N particles of an ideal gas in terms of P and V . (2)

iii. Hence obtain an expression for the internal energy of one mole of an ideal gas in terms of its temperature. (3)

c. Use the equation given in part (b) above to show that $P = \frac{1}{3}\rho\langle c^2 \rangle$ where ρ is the density of the gas. (2)

d. The density of argon is 1.61 kg m^{-3} at a pressure of $1.01 \times 10^5 \text{ Pa}$.

i. What is the root mean square speed of argon molecules at this pressure? (3)

ii. The equation for P in part (c) appears to show that the pressure of the gas is independent of its temperature. Explain. (2)

iii. The escape velocity at the Earth's surface is about 11 km s^{-1} . Does this mean that no argon molecule can ever escape from the Earth's atmosphere? Give a reason for your answer. (2)

(Total: 20 marks)

10. One end of a long steel blade is held by a G-Clamp so that it protrudes over the edge of a table. The free end of the blade is flicked so that it is set into oscillations, as shown in Figure 5.

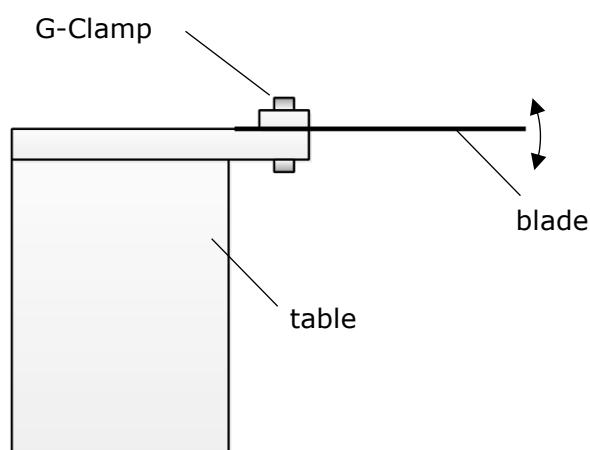

Figure 5

a.

i. Sketch a graph of displacement against time for the free end of the blade. (3)

ii. Explain any changes in the graph as time passes. (2)

iii. In what way/s, if any, will the oscillations change if, initially, a strong flick is exerted? (1)

Question continues on next page.

- b. The oscillating end of the blade makes 45 oscillations in 15 s and has an initial amplitude of 3.0 cm. For the oscillating end of the blade, find:
- the velocity while at the centre of oscillation; (3)
 - the acceleration at its maximum displacement. (3)
- c. A mass, m , is attached to the free end and the blade is set up so that the mass can oscillate in a horizontal plane. The mass m is much larger than the mass of the blade so that the mass of the blade may be neglected. The mass then performs simple harmonic motion when pulled sideways and released.
- Sketch a graph to show how the restoring force acting on the mass depends on the displacement of the mass from the centre of oscillation. (2)
 - If the restoring force is F when the displacement from the centre of oscillation is x , use the force - displacement graph drawn in part (c)(i) to find how much work is done in pulling the mass through a displacement x . (2)
 - Hence show that the potential energy, E , of the mass while at a displacement x is given by $E = \frac{1}{2}m\omega^2x^2$ where ω is the angular frequency of the simple harmonic motion and explain why the total energy of the mass is given by $E_{total} = \frac{1}{2}m\omega^2A^2$. (2, 2)

(Total: 20 marks)

11.

- a. Two large metal plates are connected across a voltage V to form a parallel plate capacitor. State how:
- the capacitance of the capacitor; (1)
 - the charge on each plate of the capacitor, (1)
change(s) as the separation of the plates is increased.
- b. The plates are now disconnected from the supply so that they form an isolated charged parallel plate capacitor. State how and give a reason why
- the charge on each plate,
 - the voltage across the capacitor,
- changes or remains the same when:
- the plates are brought closer together; (4)
 - an insulator fills the space between the plates. (4)
- c.
- Draw a circuit diagram that can be used to charge a capacitor of about $10 \mu\text{F}$ through a resistor of $10.0 \text{ M}\Omega$ using a 12 V battery and an ammeter. (2)
 - Calculate the minimum full scale deflection of the ammeter that can be used in the experiment, from which a graph of charging current against time can be obtained. (3)
 - The current decreases according to the equation $I = I_0e^{-t/RC}$. Deduce how the data from the experiment can be used to obtain a value for the capacitance of the capacitor using a straight line graph. (4)
 - Why is it preferable to use a straight line graph rather than a curve of current, I , against time, t , to obtain the value of the capacitance? (1)

(Total: 20 marks)

12. Stationary charges produce electric fields while moving charges produce magnetic fields.

- a. Describe briefly how one could demonstrate experimentally that this statement is true. (6)
- b. An electron moving with a velocity v in a horizontal plane enters a vertical uniform magnetic field of flux density B as shown in Figure 6.

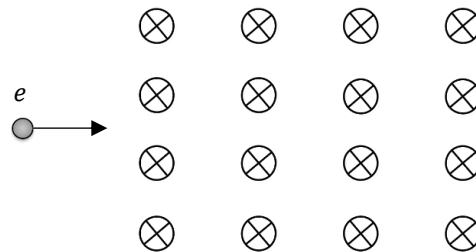

Figure 6

- i. Copy the diagram and draw the path taken by the electron. (2)
 - ii. Write down an equation for the magnetic force, F , on a length, L , of a straight conductor carrying a current, I , across a magnetic field of flux density B . (1)
 - iii. Write down an equation for the current in a conductor in terms of the number, n , of charge carriers per unit volume inside the conductor, the cross-sectional area, A , of the conductor, the drift velocity, v , of the charge carriers, and the charge, e , on each carrier. (1)
 - iv. Hence, or otherwise, derive an equation which gives the force, F_e , on the electron in terms of B , v , and e , the charge on the electron. (1)
- c. An electron travelling in a horizontal plane enters normally a vertical uniform electric field as shown in Figure 7.

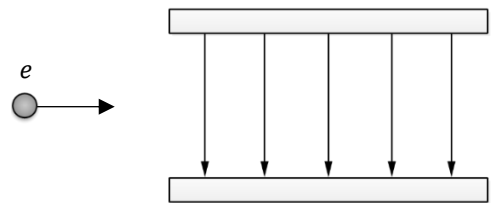

Figure 7

- i. Draw a diagram to show how the path of the electron changes as it moves in the field. (2)
- ii. Why can an electron take up energy from an electric field but not from a magnetic field? (4)

- d. An electron moving with a velocity of $2.00 \times 10^7 \text{ m s}^{-1}$ enters a region where a uniform magnetic field crosses a uniform electric field. Initially, the path of the electron is perpendicular to both fields. The electric field is produced by a pair of parallel plates which are connected to a 100 V supply and are $5.00 \times 10^{-3} \text{ m}$ apart. Calculate the magnetic flux density of the magnetic field which will produce no deflection of the electron while it travels through the crossed fields. (3)

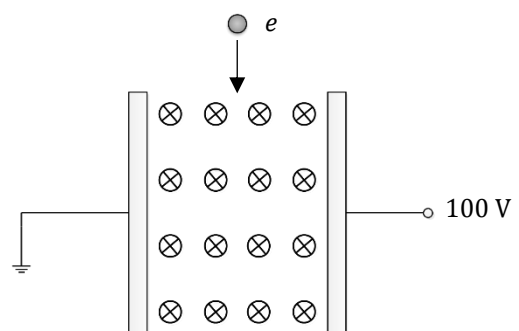

Figure 8

(Total: 20 marks)

Please turn the page.

13.

- a. A long solenoid is connected to a centre-zero microammeter as shown in Figure 9. A short magnet is allowed to fall vertically and completely through the coil.

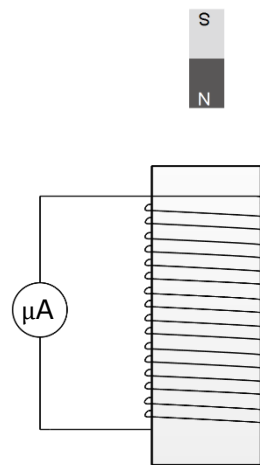

Figure 9

- i. Sketch a graph to show how the current through the meter varies with time while the magnet falls through the solenoid. (3)
 - ii. Explain the shape of your graph. (3)
 - iii. Is there any effect on the acceleration of the magnet as it enters, falls through, and leaves the solenoid? Explain. (2)
- b. A copper disc of radius 0.15 m is situated with its plane perpendicular to a magnetic field of flux density 0.025 T. The disc rotates, about an axis through its centre parallel to the field, at a rate of 20 revolutions per second.

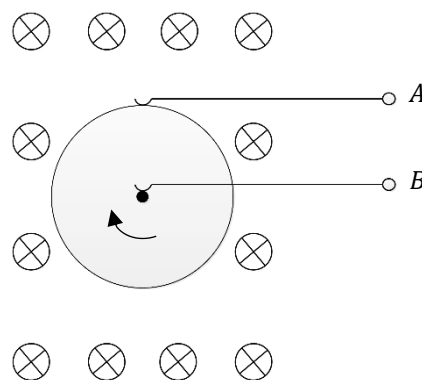

Figure 10

- i. State Faraday's law of electromagnetic induction. (2)
- ii. Calculate the magnetic flux through the disc and hence find the e.m.f. induced between the centre of the disc and its rim. (4)
- iii. Explain why the temperature of the disc increases while it is rotating. (2)
- iv. Suppose that the terminals A and B are connected by a resistor. Will there be any change in the torque required to keep the disc rotating at the same rate as before? Explain your answer and state the law backing the explanation given. (4)

(Total: 20 marks)

14.

- a. The equation for a transverse, progressive, simple harmonic wave moving in the positive x direction may be expressed in the form:

$$y = a \sin 2\pi(bt - cx)$$

where t represents time.

- i. Explain what is meant by transverse, progressive and simple harmonic wave. (3)
 - ii. What is the significance of the constants a , b , c and the ratio b/c ? (4)
- b. Figure 11 below shows a stretched string AB , driven by a vibrator at A . The end B of the string is fixed. A stationary wave is produced in the string. The distance AB is equal to one wavelength.

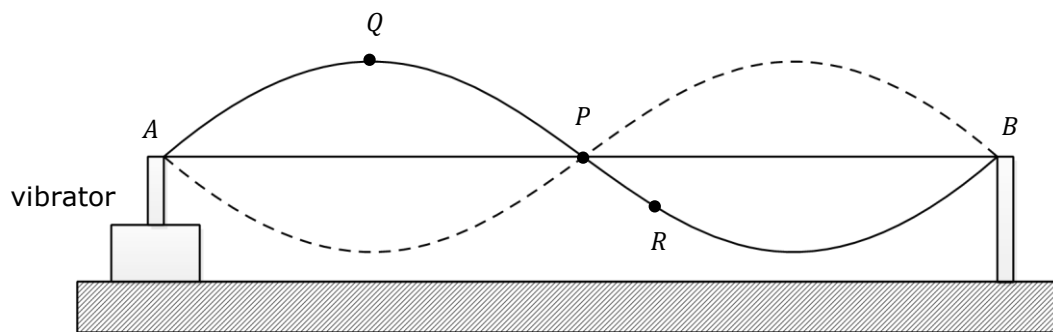

Figure 11

- i. What conditions must be obeyed so that a stationary wave may be formed in the wire? (3)
 - ii. Use the Principle of Superposition to explain why the particle at P does not move while the particle at Q has the greatest amplitude. (4)
 - iii. In what ways is the motion, if any, of the particles P , Q , and R , of the string different from each other. (3)
- c. The vibrator at A is driven by a signal generator so that its frequency may be varied. The wire AB , 1.50 m long, is at a tension of 1.20×10^2 N and has a mass of 2.30×10^{-3} kg. Calculate the frequency of the vibrator which makes the wire vibrate at its fundamental mode. (3)

(Total: 20 marks)

15. A monochromatic light source, S , is used to produce Young's interference fringes at the focal plane of the travelling microscope M .

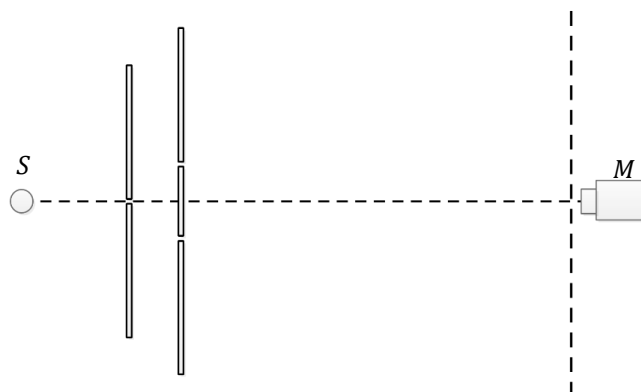

Figure 12

- a. On a copy of the diagram, explain how an interference pattern is produced in the focal plane of the microscope. (5)
- b. Describe how the fringe pattern will change if:
- monochromatic light of shorter wavelength is used; (1)
 - the microscope is moved to a position further away from the double slits; (1)
 - the single slit and source is moved to the left further away from the double slits; (1)
 - a narrower pair of slits is used. (1)
- c. A parallel beam of light from an illuminated slit consists of one red wavelength and one blue wavelength. The beam is incident normally onto a diffraction grating placed on a spectrometer turntable.
- If the spectrometer telescope is set initially in the straight through position and then turned in one direction which spectral line will be observed first? Use the grating equation to justify your answer. (2)
 - At an angle of diffraction of 53.5° a red 'line' coincides with a 'blue' line. If the blue light has a wavelength of 450 nm and the grating has 600 lines per mm, calculate the spectral order, n_{blue} , for blue light at this angle. (3)
 - What is the spectral order for red light at this angle? (1)
 - Calculate the wavelength of red light. (2)
- d. The grating is now replaced by a glass prism. Compare the spectra produced by the grating to the spectrum produced by the prism. (3)

(Total: 20 marks)



SUBJECT:	Physics
PAPER NUMBER:	III
DATE:	22 nd June 2021
TIME:	4:00 p.m. to 5:35 p.m.

Experiment: Investigating the properties of a copper wire.

Apparatus: long thin copper wire, face magnets, alternating current source, battery, voltmeter, ammeter, electronic balance, load, stands.

Diagram:

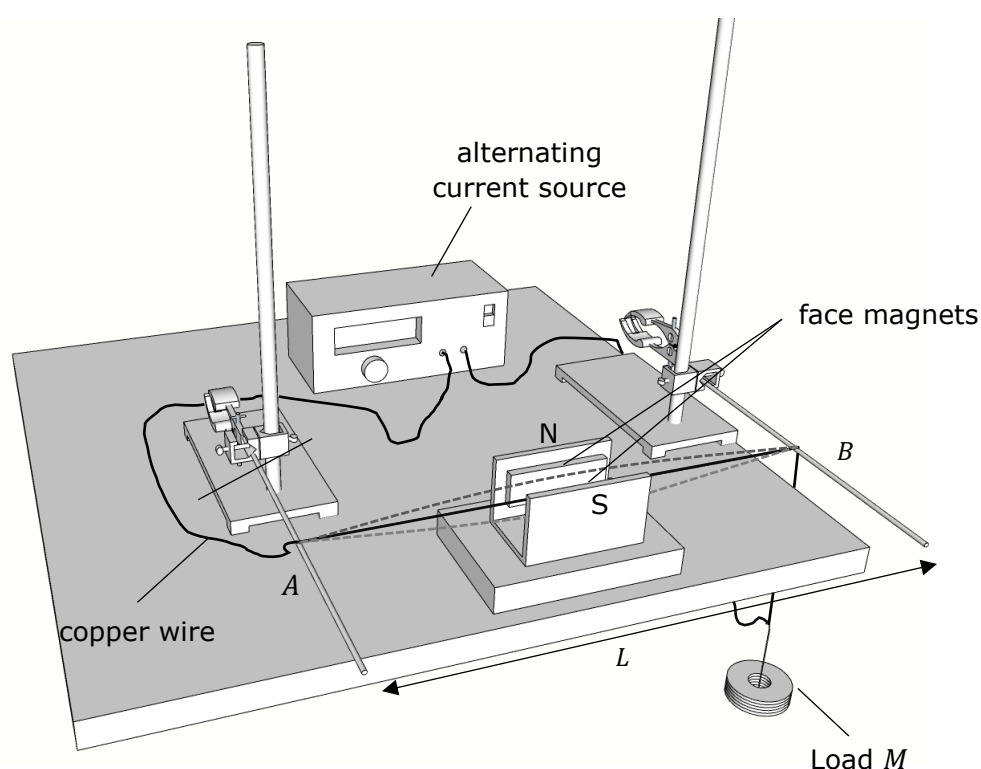

Figure 1: The experimental setup

Method – Part A:

1. The apparatus shown in Figure 1 was set up.
2. A low voltage alternating current source is connected across the ends of the copper wire.
3. The copper wire is fixed rigidly to the rod *A*, passes between the magnets and over the rod *B*. The load *M* of mass 0.5 kg creates a tension *T* that keeps the wire taut.
4. The alternating current through the wire that is positioned between the two magnets creates a standing wave on the stretched wire.

Table 1

L / m $\pm 0.01 \text{ m}$	f / Hz $\pm 1 \text{ Hz}$	f^2 / s^{-2}	L^2 / m^2	$\frac{1}{L^2} / \text{m}^{-2}$
0.25	105			
0.30	87			
0.35	74			
0.40	68			
0.45	55			
0.50	50			
0.55	47			
0.60	42			
0.65	39			

11. Calculate the value of the tension T in the wire and state its units.

_____ (2)

12. Work out and fill in the values of f^2 , L^2 and $\frac{1}{L^2}$ in Table 1 above.

(9)

13. Plot a graph of f^2 / s^{-2} on the y-axis against $\frac{1}{L^2} / \text{m}^{-2}$ on the x-axis.

(10)

14. Use the graph to determine the mass per unit length μ of the copper wire.

 _____ (5)

15. For a fixed length of wire and with the mass M hanging in air, the frequency of the alternating current source is adjusted to obtain maximum vibrating amplitude of the wire. This frequency was recorded in Table 2 as f_1 . A large beaker filled with water is then used to completely immerse the mass M in water. The wire stopped vibrating and the frequency of the alternating current source had to be readjusted to obtain maximum vibrating amplitude of the wire. This second frequency was recorded in Table 2 as f_2 .

Please turn the page.

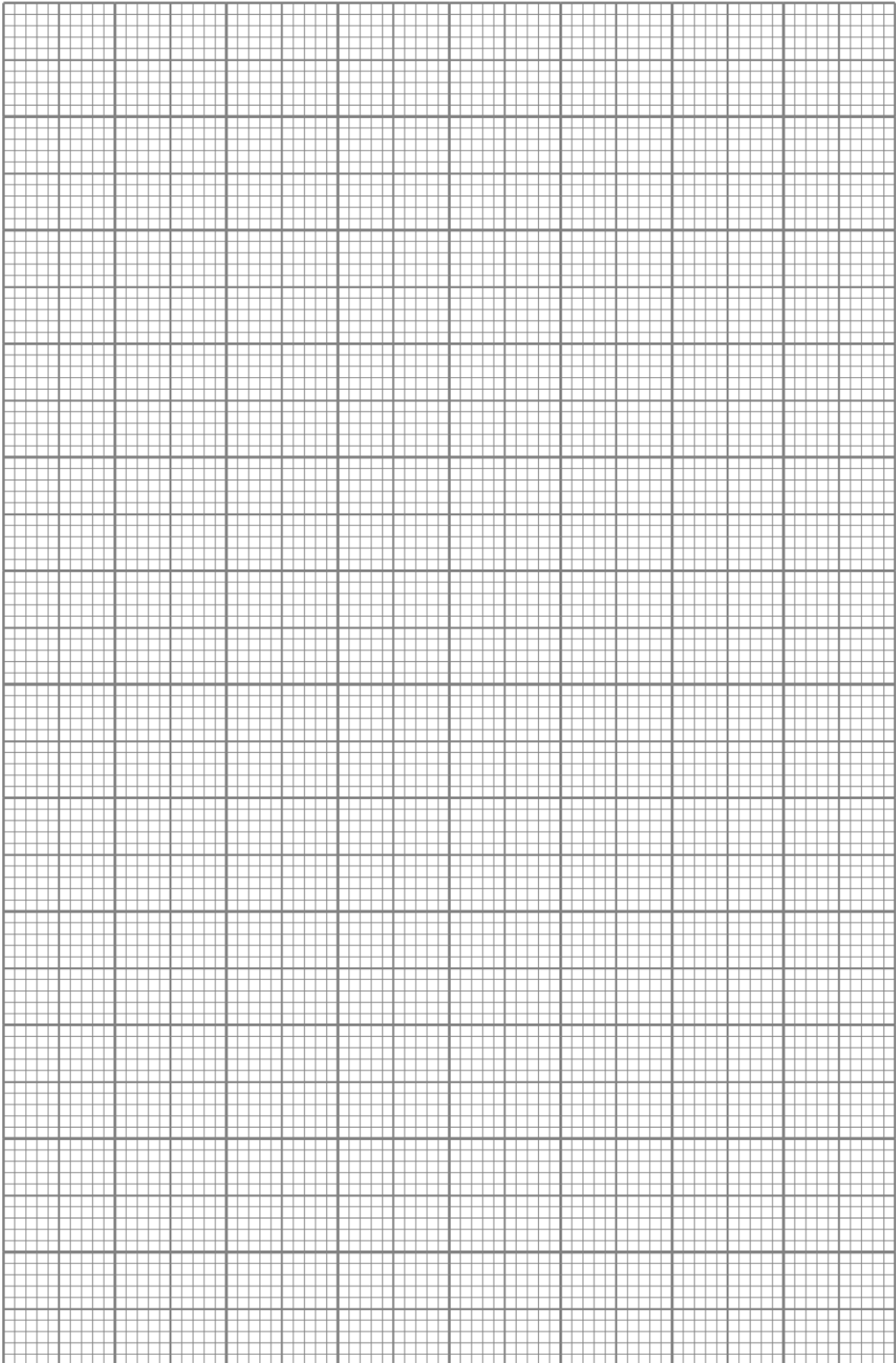

16. By making reference to the equation given in question 10, briefly explain why the frequency of the alternating current had to be readjusted when the mass was immersed in water. State any other principles that support your reasoning.

(6)

Table 2

f_1 /Hz	66
f_2 /Hz	61

17. The procedure outlined in question 15, can in fact be used to determine the relative density of the load M . The relative density is defined as the ratio $\frac{W_{air}}{W_{air}-W_{water}}$, where W_{air} is the weight of the load M in air and W_{water} is the weight of the load M when immersed in water. It can also be shown that the ratio $\frac{W_{air}}{W_{air}-W_{water}}$ is equal to $\frac{f_1^2}{f_1^2-f_2^2}$. Hence, calculate the relative density of the 0.5 kg mass and explain why the ratio has no units.

(4)

Method – Part B:

- 18. In this part of the experiment, the resistivity of the copper wire will be determined.
- 19. Pieces of unknown lengths of a uniform copper wire, of diameter 0.5 mm, are cut from a large roll.

Please turn the page.

20. The mass m of each piece of copper wire is measured using an electronic balance.
21. The ends of each piece of wire are then connected between terminals X and Y of the circuit shown in Figure 2. The current I and voltage V are measured for **each** piece of copper wire.

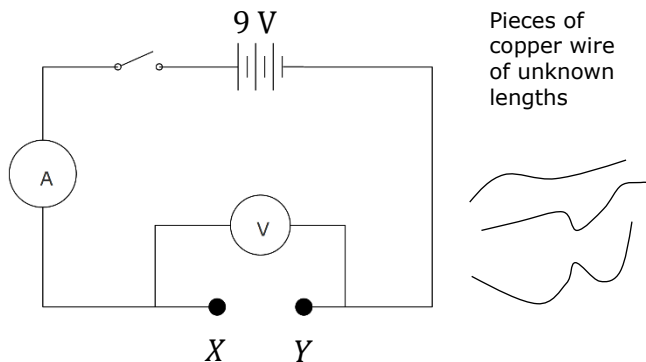

Figure 2

Table 3

m /kg ± 0.001 kg	I /A ± 0.001 A	V /V ± 0.01 V	$\frac{V}{I}$ / Ω	$\frac{m}{A}$ / $\times 10^3$ kg m ⁻²
0.009	19.71	9.0		
0.013	14.10	9.0		
0.022	8.12	9.0		
0.028	6.16	9.0		
0.033	5.61	9.0		
0.038	4.87	9.0		
0.044	4.01	9.0		
0.053	3.20	9.0		
0.061	3.03	9.0		

22. Calculate the cross-sectional area A of the wire in m².

_____ (2)

23. Show that the resistivity ρ of the copper wire can be expressed through the equation:

$$\rho = \frac{VA\mu}{Im}$$

where A is the cross-sectional area and μ is the mass per unit length of the copper wire.

 _____ (5)

24. Complete Table 3 by working out the missing values. (9)

25. Plot a graph of $\frac{V}{l}$ on the y-axis against $\frac{m}{A}$ on the x-axis. (10)

26. Use the graph and the value of μ obtained in question 14 to determine the resistivity of the copper wire.

(6)

27. State **ONE** source of error and **ONE** corresponding precaution that could be taken during part B of the experiment.

(2)

Please turn the page

