



---

SUBJECT:	<b>Physics</b>
PAPER NUMBER:	I
DATE:	29 <sup>th</sup> August 2022
TIME:	9:00 a.m. to 12:05 p.m.

---

**A list of useful formulae and equations is provided. Take the acceleration due to gravity  $g = 9.81 \text{ m s}^{-2}$  unless otherwise stated.**

**SECTION A**

**Attempt all EIGHT questions in this section. This section carries 50% of the total marks for this paper.**

1. The Froude's number,  $F_R$ , is a significant figure in naval architecture. It determines the wave making resistance of a ship moving through water. Its mathematical representation is given by the following equation:

$$F_R = \frac{v}{\sqrt{gL_{WL}}}$$

where  $v$  is the velocity of a ship through water,  $g$  is the acceleration due to gravity and  $L_{WL}$  is the length of the ship at the waterline level.

- Define the terms vector and scalar quantities. (2)
- State whether  $v$ ,  $g$  and  $L_{WL}$  are vector or scalar quantities. (3)
- Show that  $F_R$  is dimensionless. (3)
- Calculate Froude's number for a ship whose length at the waterline level is 21 m while moving at  $3.6 \text{ m s}^{-1}$ . (2)

**(Total: 10 marks)**

2. Momentum is conserved in a collision or explosion, assuming no external forces are involved. Total energy is also conserved but the kinetic energy might not be.

- Distinguish between perfectly elastic and perfectly inelastic collisions. (2)
- In Dubai, the police authorities make use of drones that can carry police officers around in flight. The drone and police officer, with a total mass of 210 kg, supports itself mid-air in a stationary position by imparting a downward velocity  $v$  to all the air in 6 small circles below the propellers, each having an area of  $1.8 \text{ m}^2$ .
  - Show that the volume of air pushed downwards per second is given by  $10.8v$ . (2)
  - If the density of air is  $1.1 \text{ kg m}^{-3}$ , calculate the value of  $v$ . (4)
- Determine the power needed to support the drone in this way, assuming no energy is lost. (2)

**(Total: 10 marks)**

3. On the 14<sup>th</sup> September 2015, Terry Grant, a stunt driver, performed a world record breaking challenge by driving a newly launched sports car, through a vertical loop-the-loop of diameter 19.08 m. The mass of the car and driver was 1775 kg. From start to finish Mr Grant maintained a constant speed.

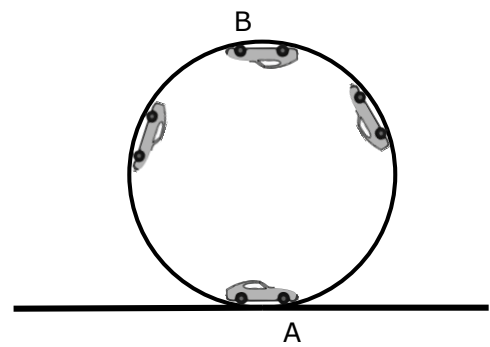

Figure 1

- Explain how Mr Grant is still accelerating even though he is driving through the circular loop at constant speed. (2)
- Copy the diagram of Figure 1. On the same diagram, draw and label clearly the forces acting on the car at positions A and B. (1)
- If Mr Grant were to experience weightlessness at position B of the loop, briefly explain how and when this would happen by referring to the forces drawn in part (b). (2)
- If the car is not to lose contact with the track, calculate the minimum speed with which it should enter the loop-the-loop. (2)
- The car goes through the loop at 1.5 times the minimum speed calculated in part (d). Calculate the centripetal force acting on the car as it goes round the loop. (3)

**(Total: 10 marks)**

4. A physics teacher sets up the two electrical circuits shown in Figure 2 and Figure 3.

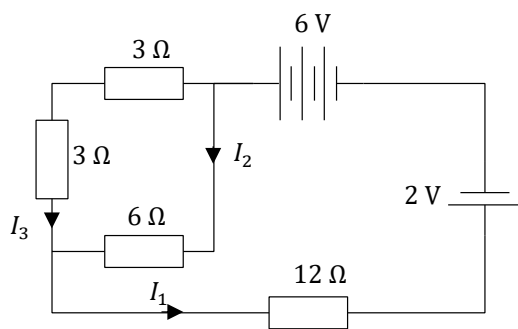

Figure 2

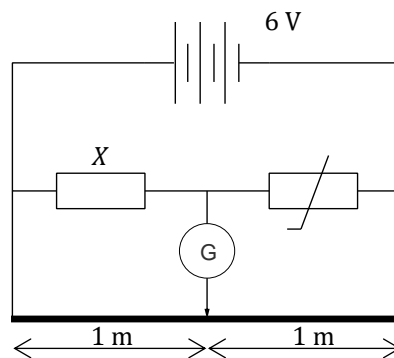

Figure 3

- Calculate currents  $I_1$ ,  $I_2$  and  $I_3$  assuming the cells have **no** internal resistance. (5)
- State the law used to work out  $I_1$ ,  $I_2$  and  $I_3$ . (1)
- At 25°C, the thermistor in Figure 3 has a value of 800 Ω and the galvanometer is not reading any current flow. When the thermistor is heated to a temperature of 40°C, its resistance drops to 300 Ω.

If the resistance wire used is uniform, calculate the value of the resistor which needs to be added in parallel to the fixed resistor  $X$  so that no current flows through the galvanometer. (4)

**(Total: 10 marks)**

5. A file cabinet with two drawers is 0.90 m high ( $a$ ) and 0.60 m wide ( $b$ ), as shown in Figure 4. The cabinet is filled with documents such that its centre of gravity is at its centre and the system is in static equilibrium. The angle of the incline is increased until the file cabinet is just about to tip over. Assume that friction is large enough to prevent sliding.

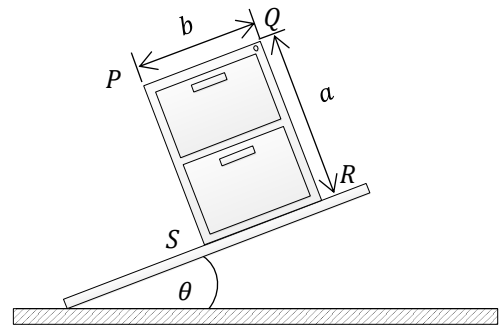

Figure 4

- a. State **TWO** conditions under which the system will remain in static equilibrium. (2)
- b. Which of the corners  $P, Q, R$  or  $S$  is likely to act as the pivot when the cabinet is about to tip over? (1)
- c. Copy the diagram in Figure 4 and draw the forces acting on the cabinet and the pivot. (3)
- d. Calculate the largest angle  $\theta$  for which the cabinet does **not** tip over. (4)

**(Total: 10 marks)**

6. Two students set out to find the Young's modulus of a thin copper wire by carrying out an experiment. Two long thin copper wires and a fixed support are provided along with some weights. Describe the experiment that they should carry out. The description should include:

- a. a list of any other apparatus that is needed; (1)
- b. a diagram of how the apparatus should be set up; (2)
- c. a description of the method used to carry out the experiment, including a table of the data to be recorded from the experiment; (2, 1)
- d. **ONE** precaution to be undertaken during the experiment; (1)
- e. a sketch of a stress-strain graph for copper; (2)
- f. the calculations that would be necessary if one were to determine the Young's modulus for copper. (1)

**(Total: 10 marks)**

7. The cell in the circuit shown in Figure 5 has an emf of 2.5 V and an internal resistance,  $r$ . Wire  $XY$  is 2 m long and the resistance of resistor  $R$  is  $3 \Omega$ .

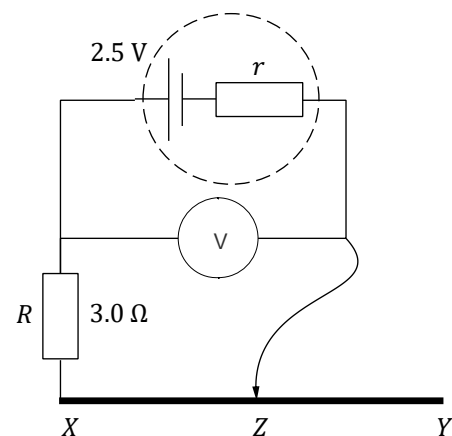

Figure 5

- a. The wire  $XY$  has a resistivity of  $1.6 \times 10^{-6} \Omega \text{ m}$  and a radius 0.55 mm. Calculate the resistance of length  $XZ$  of the wire if the contact  $Z$  is placed at  $\frac{3}{4}$  its total length. (2)
- b. The contact  $Z$  is now placed in the middle of the wire  $XY$ . The voltmeter reads 2.1 V. Calculate the internal resistance,  $r$ , of the cell. (4)

- c. Calculate the power used by the wire  $XY$  with  $Z$  in this position. (2)
- d. The contact  $Z$  is now moved towards  $X$ . Explain how the voltage read by the voltmeter will change and give a reason for your answer. (2)

**(Total: 10 marks)**

8. One of the world’s best cliff divers, of mass 65 kg, leaps from point  $A$ , reaches the highest point at  $B$  and touches the water below at  $C$ , as shown in Figure 6. Although the cliff diver performs a few somersaults in the air to gain points for the dive, her centre of gravity follows a projectile path.

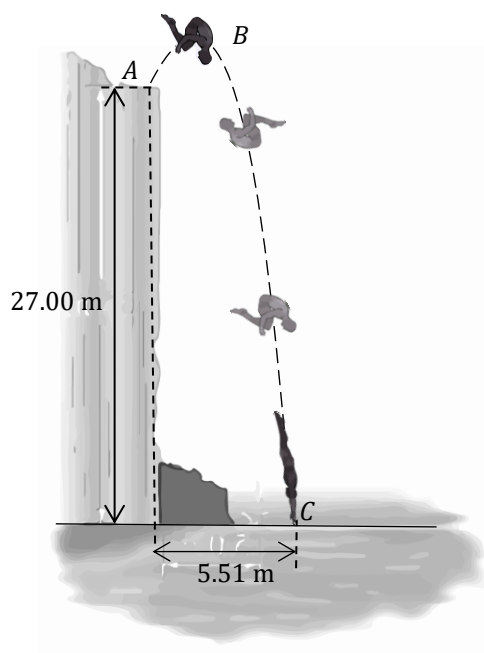

Figure 6

- a. If the cliff diver takes 0.5 s to reach point  $B$ , calculate her initial vertical velocity with which she leaps from point  $A$ . (2)
- b. Calculate the maximum height above sea level that the cliff diver reaches at point  $B$ . (2)
- c. State **ONE** assumption that is necessary to calculate answers to parts (a) and (b). (1)
- d. During the somersaults, the cliff diver brings her arms and legs closer to her centre of gravity. Briefly explain how this helps the cliff diver perform more somersaults. (1)
- e. As the cliff diver is about to enter the water, she extends her legs and aligns her arms to her body to enter the water at an angle. She enters the water at a horizontal distance of 5.51 m as measured from beneath  $A$ . Calculate the velocity with which the diver enters the water and the angle with the vertical with which she enters the water. (4)

**(Total: 10 marks)**

**SECTION B**

**Attempt any FOUR questions in this section. Each question carries 20 marks. This section carries 50% of the total marks for this paper.**

- 9.
  - a. Explain what is meant by energy. (1)
  - b. Distinguish between gravitational potential energy, elastic potential energy and kinetic energy. (3)
  - c. A ball of mass  $m = 0.1$  kg is projected vertically upwards with a velocity of  $15 \text{ m s}^{-1}$  and eventually returns to the point from where it was projected. Assume that effects of air resistance on the motion of the ball are negligible.
    - i. Sketch **FOUR** graphs to show how the velocity, kinetic energy, potential energy and momentum vary with time. (4)
    - ii. Calculate the potential energy at maximum height. (2)
    - iii. Determine the potential energy of the ball at  $\frac{3}{4}$  of the maximum height while it is moving upwards. (3)

- d. A block of mass 0.450 kg is at rest on a horizontal frictionless surface, as shown in Figure 7. The block is compressed against a spring to the position A and released. The block travels a distance  $d$  up the inclined plane, passing through position B and stopping at position C. Positions B and C are at heights  $\frac{h}{2}$  and  $h$  above ground respectively. The compression distance  $x_i$  is 10.0 cm and the spring constant is  $k$  is  $525 \text{ N m}^{-1}$ .

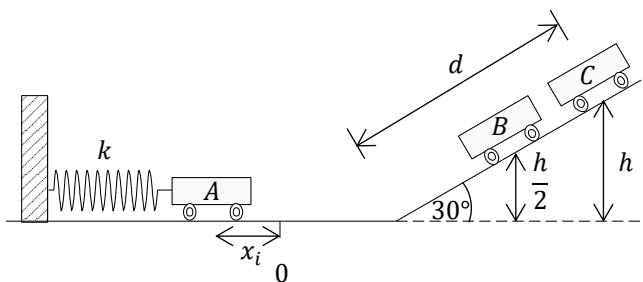

Figure 7

The compression distance  $x_i$  is 10.0 cm and the spring constant is  $k$  is  $525 \text{ N m}^{-1}$ .

- Find the maximum distance  $d$  the block travels up the frictionless incline. (2)
- Calculate the speed of the block as it is going through position B. (3)
- State the effect, if any, that a stiffer spring would have on the answers worked in parts (d)(i) and (d)(ii). (2)

**(Total: 20 marks)**

10. Figure 8 shows two cylinders with moment of inertia  $I_1$  and  $I_2$ . Both cylinders are initially at rest, and they can rotate freely and independently about a frictionless vertical axle. Cylinder 1 is accelerated, about the vertical axle, from rest by a light string (not shown on diagram) wound on the outside curved surface. Cylinder 1 is accelerated at  $10 \text{ rad s}^{-2}$  for 1.5 s, at the end of which the string is completely unwound. The moment of inertia of a cylinder is given by  $I = \frac{1}{2}Mr^2$ .

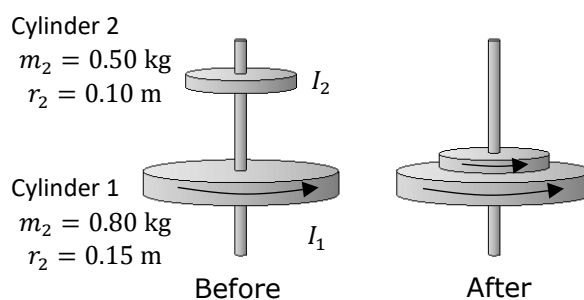

Figure 8

- Define moment of inertia. (1)
- Calculate the moment of inertia of **each** cylinder. (2)
- Determine the magnitude of the tangential force with which the string was pulled to set cylinder 1 rotating. (3)
- Calculate the final angular velocity reached by the cylinder after the string was completely unwound. (2)
- Determine the total number of turns rotated by the cylinder as it was being accelerated. (2)

When cylinder 1 is rotating at maximum angular speed, the second cylinder, initially at rest, drops onto the first cylinder. Because the surfaces are rough, the two cylinders eventually reach the same angular speed  $\omega$ .

- Calculate  $\omega$ . (3)
- State the principle used to work out  $\omega$ . (2)
- Show that KE is lost in this situation and calculate the ratio of the final KE to the initial KE. (5)

**(Total: 20 marks)**

11. A student learns that the isotope of radioactive substance Polonium-218,  ${}_{84}^{218}\text{Po}$ , is used to eliminate static electricity in industrial processes. The student wants to explore more its radioactive characteristics and determine its half-life. She uses a Geiger Muller tube and radiation counter together with a small source of the isotope Polonium-218.
- Explain what is meant by radioactivity and half-life. (2)
  - Starting with the equation for the decay of any radioactive substance with time, derive the relationship  $T_{\frac{1}{2}} = \frac{\ln 2}{\lambda}$ . (3)
  - If the decay constant of Polonium-218 is  $0.00385 \text{ s}^{-1}$ , calculate its half-life in minutes. (2)
  - The initial activity of this sample of Polonium is  $1.15 \times 10^{19} \text{ Bq}$ . Sketch a graph that shows how the number of radioactive atoms varies with time. The graph should clearly show the value of the original number of radioactive atoms and the value of the number of radioactive atoms after one half-life. (3)
  - Calculate the mass in grams of radioactive Polonium-218 that are left in the sample after 12 minutes. Take 1 mole to have  $N_A = 6.023 \times 10^{23}$  atoms. (3)
  - Polonium-218 decays to form Lead-214 (Pb). State the type of radiation emitted and write down the decay equation. (2)
  - List **TWO** chief properties of the radiation particle emitted by Polonium-218 and hence, explain the use of Polonium to eliminate static electricity. (3)
  - If the atomic mass of polonium-218 is 218.00897 u, that of lead-214 is 213.9998 u and that of the emitted particle is 4.004 u, calculate the energy that is released in the decay process. (2)

**(Total: 20 marks)**

12. The I-V characteristics of a metallic conductor, a filament lamp, a thermistor and a diode are all different.
- Describe an experiment to investigate the I-V characteristics of the four components listed above. The description should include:
    - a list of apparatus; (1)
    - a well labelled diagram of the circuit to be used; (2)
    - a detailed description of the procedure to be adopted; (2)
    - a sketch of the typical graphs that would be obtained from the experiment; (4)
    - TWO** precautions to undertake while carrying out the experiment. (2)
  - State Ohm's law and describe how the electrical resistance of the metallic conductor can be determined from the I-V graph. (3)
  - A light dependent resistor is used to change the output voltage of a potential divider circuit.
    - Draw the potential divider circuit. (2)
    - Explain in what way light intensity affects the output voltage of the circuit drawn. (2)
    - The output voltage from the potential divider circuit, under constant light conditions, provides a nichrome wire with 4 C of charge in 6 minutes. Calculate the drift speed of

electrons in the nichrome wire given that it has a cross-sectional area of  $4.9 \times 10^{-8} \text{ m}^2$  and nichrome has  $9 \times 10^{28}$  electrons per cubic metre. (2)

**(Total: 20 marks)**

13.

- a. Describe an experiment to determine the internal resistance of a cell. The description should include:
  - i. a list of the electronic components needed and the measuring instruments; (2)
  - ii. a well labelled diagram of the circuit; (2)
  - iii. a description of the procedure to be adopted; (3)
  - iv. a list of the data that needs to be collected; (2)
  - v. a sketch of a suitable graph and the calculations that need to be carried out to determine the internal resistance of the cell; (3)
  - vi. **ONE** precaution to be undertaken during the experiment. (1)
  
- b. Briefly explain the importance of internal resistance in high tension supplies. (2)

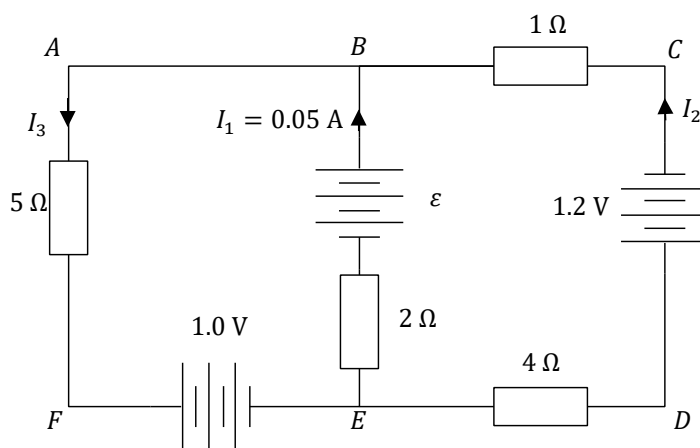

Figure 9

- c. Figure 9 shows a circuit with three e.m.f. sources, one of which is of unknown value  $\epsilon$ . Determine the currents  $I_2$  and  $I_3$  as well as the unknown e.m.f.  $\epsilon$ . (5)

**(Total: 20 marks)**

14. Silicon is one of the most widely used semiconductor materials. In its intrinsic form, it has four outer valence electrons.

- a. Describe, with the aid of a diagram, the basic bonding structure of a pure silicon lattice. (3)
  
- b. The energy levels of silicon atoms give rise to the formation of the valence band, the conduction band and the forbidden band. Briefly describe how and why this happens. (6)
  
- c. The positions, widths and presence of the valence band, the conduction band and the forbidden band in insulators, semiconductors and metallic conductors are different. State how these are different in **all** three materials. (3)
  
- d. Briefly compare the electron population in the above bands, for **each** type of material. (3)
  
- e. How does a rise in temperature affect the above populations? (1)

- f. Pure silicon is doped with phosphorus atoms to create a n-type extrinsic semiconductor. Phosphorus has five outer valence electrons.
- i. State whether electrons are the majority or minority charge carriers in the n-type semiconductor. (2)
  - ii. Sketch a detailed well-labelled energy band diagram for this n-type semiconductor. (2)

**(Total: 20 marks)**

15. In the early 1900s, Einstein proposed that experimental results in photoelectricity could be explained by applying a quantum theory of light. The photoelectric effect is the emission of electrons when electromagnetic radiation, such as light, hits a material. Electrons emitted in this manner are called photoelectrons.

- a. Briefly explain what Einstein postulated in the quantum theory of light. (3)
- b. State **TWO** aspects of the experimental results from the photoelectric experiment that could **not** be explained by classical physics. (4)
- c. Write down Einstein's equation for the photoelectric effect and state the meaning of **each** term in the equation. (3)
- d. Which of the terms in Einstein's equation is associated with:
  - i. particular experimental conditions; (1)
  - ii. particular metal species? (1)
- e. A monochromatic light source provides light of wavelength 450 nm and this liberates  $3.2 \times 10^{11}$  photoelectrons per second from a metal surface causing the metal to acquire a positive potential. The threshold wavelength for this metal is 550 nm.
  - i. Calculate the size of the photoelectric emission current. (2)
  - ii. If the light source were replaced with an otherwise identical 50 W one, describe the changes, if any, in the photoelectric current. (1)
  - iii. The light source is replaced by a 100 W source operating at 600 nm. Will this affect the photoelectric current? Explain. (2)
  - iv. The work function energy of this metal is  $0.37 \times 10^{-18}$  J. Using the light source of wavelength 450 nm, determine the potential on the metal plate that will eventually build up and prevent further loss of electrons from the metal surface. (3)

**(Total: 20 marks)**





SUBJECT:	<b>Physics</b>
PAPER NUMBER:	II
DATE:	30 <sup>th</sup> August 2022
TIME:	9:00 a.m. to 12:05 p.m.

**A list of useful formulae and equations is provided. Take the acceleration due to gravity  $g = 9.81 \text{ m s}^{-2}$  unless otherwise stated.**

### SECTION A

**Attempt all EIGHT questions in this section. This section carries 50% of the total marks for this paper.**

- State the direction of net heat flow in terms of temperature when no work is done. (1)
  - Distinguish between the terms specific heat capacity and specific latent heat. (4)
  - An ice cube tray is filled with 200 g of water at 20°C. It is placed in the freezer compartment of a refrigerator. Calculate the energy that must be removed from the water to turn it into ice cubes at -5°C. (5)  
[specific heat capacity of water 4186 J kg<sup>-1</sup> K<sup>-1</sup>; latent heat of fusion 333,700 kJ kg<sup>-1</sup>; specific heat capacity of ice 2100 J kg<sup>-1</sup> K<sup>-1</sup>] **(Total: 10 marks)**
- Figure 1 shows a schematic diagram of a heat engine. Heat  $Q_H$  from the high temperature reservoir is used by the heat engine to deliver work  $W$  and reject heat  $Q_C$  into the cold reservoir.
  - Draw a similar labelled schematic diagram for a heat pump and explain any terms used. (2)
  - Briefly explain the function of the heat pump. (2)
  - State the second law of thermodynamics in terms of heat engines. (1)
  - Two heat engines  $P$  and  $Q$  operate between a high temperature reservoir  $T_H$  (720 K) and a cold temperature reservoir  $T_C$  (310 K) and have the same rate of heat input. The power output of engine  $P$  is  $2.1 \times 10^4 \text{ W}$ .
    - If heat engine  $P$  operates on the Carnot cycle and has a maximum theoretical efficiency given by  $\eta = 1 - \frac{T_C}{T_H}$ , calculate the rate of heat input to this engine. (2)
    - Heat engine  $Q$  has an efficiency of 32%. Calculate the power output from this engine. (2)
    - Mention **ONE** limiting factor of efficiency in heat engines/pumps. (1)

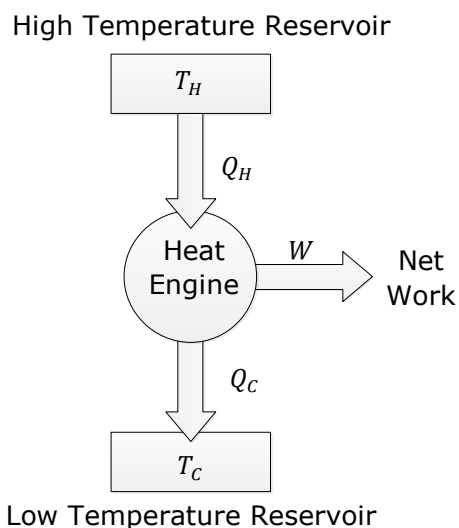

Figure 1

- 3.
- Write down the equation for the acceleration due to gravity,  $g$ , on the Earth's surface in terms of the mass of the Earth,  $M_E$ , the radius of the Earth,  $R_E$ , and the constant,  $G$ . (1)
  - State **TWO** assumptions necessary for the equation derived in part (a) to hold true. (2)
  - Sketch the gravitational field lines and equipotential surfaces for Earth. (2)
  - Show that the period  $T_M$  of rotation of the Moon around Earth is given by:
 
$$T_M^2 = \frac{4\pi^2 R_M^3}{GM_E}$$
 where  $R_M$  is the radius of the Moon's orbit. (3)
  - State **TWO** assumptions made in deriving the equation for  $T_M$ . (2)

**(Total: 10 marks)**

- 4.
- Define electric field strength at a point. (2)
  - Point charges  $A$ ,  $B$  and  $C$  are held in place in a straight line as shown in Figure 2. Another point charge  $P$  is introduced as shown in Figure 2.
    - State the sign of charge  $B$  for  $P$  to remain stationary. (1)
    - Draw a free body diagram to show the forces acting on  $P$  when stationary. (2)
    - Find the magnitude of the charge of  $B$  in order for  $P$  to remain stationary. (4)
    - How would your answer to part (iii) change if  $P$  was negatively charged? (1)

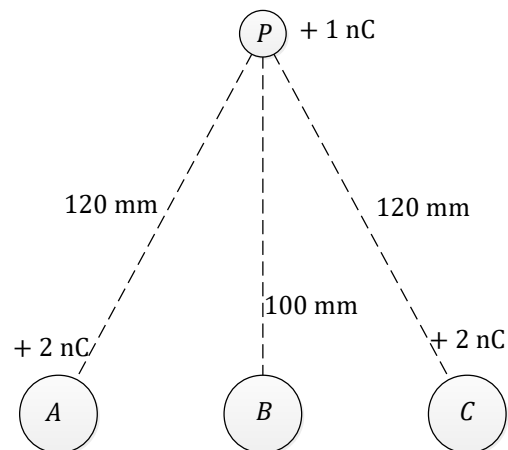

Figure 2

**(Total: 10 marks)**

- A basic radio tuning circuit uses a combination of resistors, capacitors, and inductors. When connected to an alternating current source, capacitors and inductors offer reactance.
  - Distinguish between resistance and reactance. (1)
  - On the same axes, sketch **TWO** well-labelled graphs that show the dependency on frequency of the reactance of both a capacitor and an inductor. (2)
  - Explain why an alternating current can flow through a capacitor circuit but a direct current cannot flow through. (2)
  - An alternating voltage source is connected to an inductor with inductance 2 H and zero resistance. The voltage varies sinusoidally as given by  $V = 7.2 \sin(100\pi t)$ .
    - Determine the frequency of the alternating voltage source. (1)
    - Calculate the peak current that flows through the inductor. (2)
    - If the inductor is to be replaced by a capacitor having the same reactance, what value of capacitance should the capacitor have? (2)

**(Total: 10 marks)**

- 6.
- a. Draw the magnetic field lines:
    - i. around an isolated bar magnet; (1)
    - ii. around a long solenoid. Clearly indicate the direction of flow of current through the solenoid. (2)
  - b. A solenoid has a magnetic core of relative permeability  $\mu_r = 1.5$ . The solenoid has 10 turns per centimetre and carries a current of 0.5 A. The permeability of free space  $\mu_0$  is  $4\pi \times 10^{-7} \text{ H m}^{-1}$ .
    - i. Calculate the flux density in the middle of the solenoid. (2)
    - ii. The magnetic core is removed. How will this affect the magnitude of the flux density? (1)
    - iii. A second coil of 100 turns and radius 0.01 m is wound around the middle of the first solenoid with no magnetic core. Calculate the flux linkage. (2)
    - iv. The current in the solenoid is turned off. Calculate the flow of charge through the second coil if it is part of a circuit of total resistance  $5 \Omega$ . (2)

**(Total: 10 marks)**

- 7.
- a. Draw a simple diagram to show how white light is dispersed when it passes through a glass prism. (2)
  - b. A converging lens has a focal length,  $F$ , of 5.00 cm. An object, 2.5 cm high is placed 2.0 cm in front of the lens.
    - i. Draw a ray diagram, to scale, to show how the image is formed. (2)
    - ii. State **all** the properties of the image formed. (3)
    - iii. Measure the image distance. (1)
    - iv. If the object is moved to 4.5 cm from the lens, calculate the height of the image. (2)

**(Total: 10 marks)**

- 8.
- a. Briefly explain what the Big Bang Theory is about. (2)
  - b. List **FOUR** main aspects or phenomena or physical laws that support this theory. (4)
  - c. Use Hubble's law to show how the age of the Universe can be estimated. Calculate the age of the Universe in years given that  $H_0 = 2.37 \times 10^{-18} \text{ s}^{-1}$ . (4)
- (Total: 10 marks)**

## SECTION B

**Attempt any FOUR questions in this section. Each question carries 20 marks. This section carries 50% of the total marks for this paper.**

9. Conduction and radiation are two modes of heat transfer.
- a. State the other **TWO** modes of heat transfer and describe how heat is transferred in **each** of them. (4)
  - b. It is known that black surfaces are both good absorbers and good radiators of heat.
    - i. Briefly describe a perfect blackbody in terms of its absorption, emission and transmission properties. (3)

**Questions continue on next page.**

- ii. Sketch on the same axis two graphs that shows how the blackbody radiation emission intensity varies with wavelength for two different temperatures  $T_1$  and  $T_2$  with  $T_2 > T_1$ . Clearly identify each graph by labelling it according to the temperature. (4)
- iii. Explain how the graph sketched in part (b)(ii) can be used to determine the total emission power per square metre. (2)

- c. Two containers  $P$  and  $Q$  are joined together by two pieces of rod: a copper rod and an iron rod, as shown in Figure 3. Both rods have a cross-sectional area of  $6.0 \times 10^{-6} \text{ m}^2$ . The length of the copper rod is 0.50 m and that of the iron rod is 0.25 m. Container  $P$  contains boiling water and container  $Q$  contains a mixture of ice and water at  $0^\circ\text{C}$ . Calculate the rate of heat transfer passing from the boiling water to the ice bath. Assume there is no heat loss to the surrounding air. [thermal conductivity of copper is  $401.0 \text{ W m}^{-1} \text{ K}^{-1}$ ; thermal conductivity of iron  $80.2 \text{ W m}^{-1} \text{ K}^{-1}$ ]

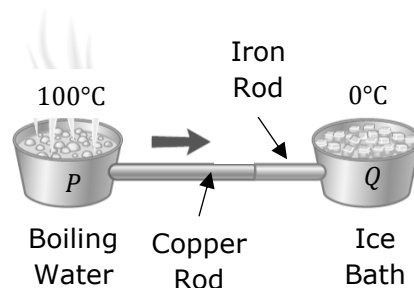

Figure 3

(7)

**(Total: 20 marks)**

10. When the pressure, volume and temperature of a gas change, it is useful to represent these changes on P-V diagrams. The graph shown in Figure 4 shows isotherms for one mole of ideal gas. The heat capacity at constant volume,  $C_V$  is  $20.8 \text{ J K}^{-1} \text{ mol}^{-1}$ .

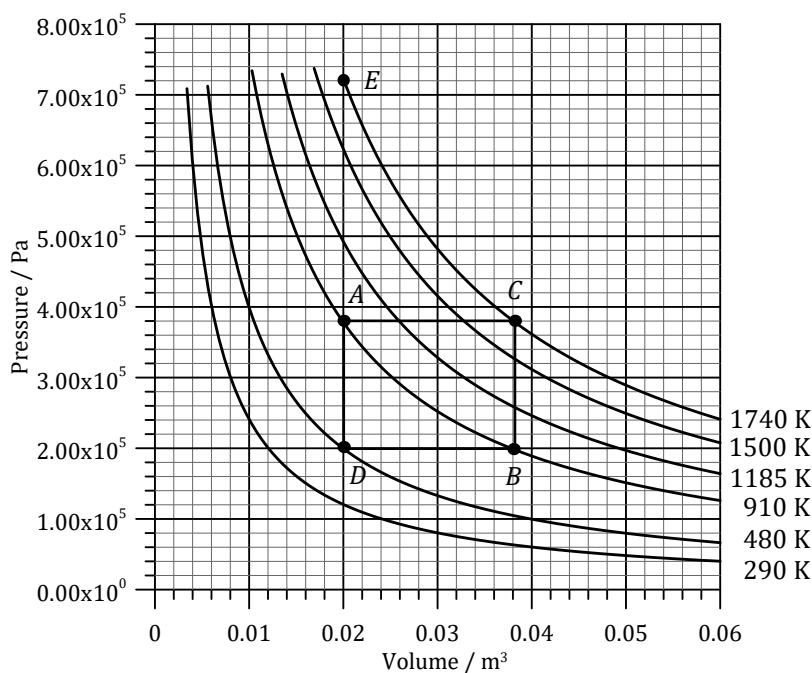

Figure 4

- a. Show, by considering at least three points on the graphs, that the ratio  $pV/T$  is constant. (3)
- b. Consider the changes in the state of the gas  $A$  to  $C$  and  $D$  to  $E$ . Which of the changes is an isobaric process and which is an isovolumetric process? (2)
- c. Which of the gas laws is being obeyed if the state of the gas changes from  $A$  to  $B$  along the isotherm? (1)
- d. Calculate the value of the heat capacity at constant pressure  $C_p$ . (1)
- e. Work out the heat energy that needs to be supplied to the gas to change its state from  $A$  to  $E$  in a straight line. (2)

- f. Use the graph to calculate the work done on the gas as its state is changed from *C* to *A*. (2)
  - g. Calculate the net work done on the gas as it goes through the cycle *CADB*. (3)
  - h. The change in internal energy of the gas as it goes from *A* to *E* or from *A* to *C* is the same. Explain why. (2)
  - i. Write down the first law of thermodynamics in its mathematical form and apply this to the isothermal change *A* to *B* to show that heat is supplied to the gas in this process. Hence, explain why this heat energy does not increase the temperature of the gas. (4)
- (Total: 20 marks)**

11. The kinetic theory of gases explains the behaviour of gases through the microscopic motion of the gas molecules themselves.

- a. Consider an ideal gas confined in a cube as shown in Figure 5. Of all the molecules, consider a single gas molecule of mass *m* that is moving with a velocity *u<sub>x</sub>* in the positive *x*-direction. The molecule moves backwards and forwards in the box, striking the end faces normally and making elastic collisions.

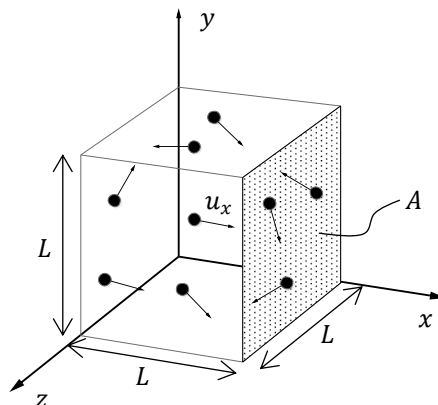

Figure 5

- i. Show that the time *t* between collisions with the same wall is  $t = \frac{2L}{u_x}$ . (2)
  - ii. What is the change in momentum of the molecule per collision with wall A? (2)
  - iii. If it is assumed that the box contains *N* identical molecules, each of mass *m*, all moving along the *x*-direction with speed *u<sub>x</sub>*, and making elastic collisions at the ends, show that the average force *F* on wall A is  $F = \frac{Nmu_x^2}{L}$ . (3)
  - iv. A better model of molecular motion assumes that the motion is random. By making this assumption obtain the better equation for *F*: 
$$F = \frac{Nm\langle c^2 \rangle}{3L}$$
 where  $\langle c^2 \rangle$  is the mean square speed of the molecules in the box. (3)
  - v. Hence show that the pressure of the gas inside the box is  $P = \frac{Nm\langle c^2 \rangle}{3V}$ , where *V* is the volume of the cube. (2)
- b. State **FOUR** assumptions that were assumed along the derivation in part (a). (4)
  - c. The atomic mass number for oxygen is 16, and that of Nitrogen is 14. Calculate the difference in mass between a room filled with 1.5 moles of oxygen gas (*O*<sub>2</sub>) and a room filled with 2.3 moles of Nitrogen gas (*N*<sub>2</sub>). (4)
- (Total: 20 marks)**

**Questions continue on next page.**

12. Figure 6 shows an experimental setup that can be used to measure the acceleration due to gravity. In its rest position, the ball touches the copper contacts and therefore the capacitor is charged until the voltage across it reaches 6 V. When the ball is released, the circuit is open, and the capacitor starts discharging through the 2 kΩ resistor. As soon as the ball reaches the thin metal plate, it breaks through it and therefore it breaks the lower circuit, and the capacitor stops discharging. Figure 7 shows the voltage across the capacitor during the experiment.

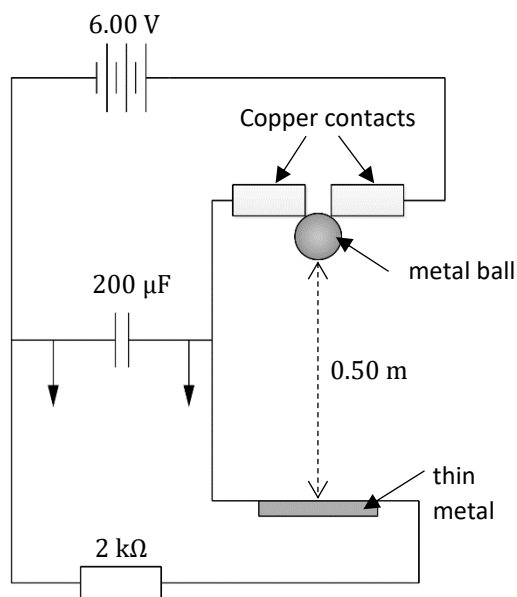

Figure 6

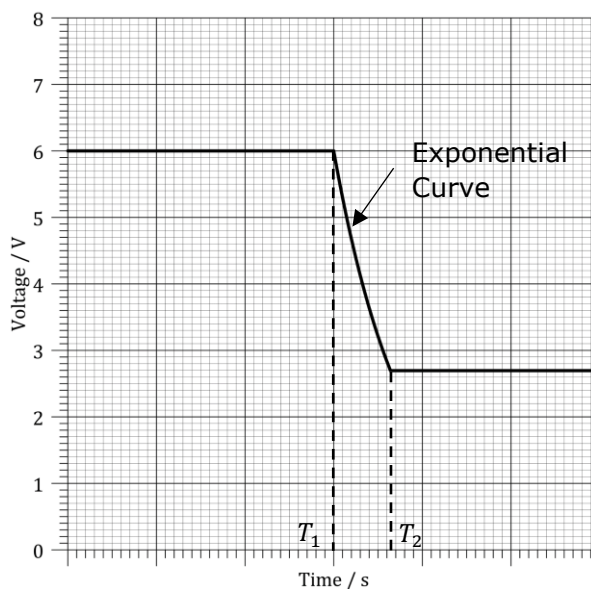

Figure 7

- a.
  - i. Explain what is happening at times  $T_1$  and  $T_2$ . (2)
  - ii. Calculate the charge that flows through the resistor by the time the ball hits the lower thin metal plate. (3)
  - iii. Determine the maximum current that flows through the resistor and the time constant for the discharging circuit. (2)
  - iv. By using the equation for capacitor discharge, determine the current flowing through the resistor 0.15 s after the event at time  $T_1$ . (2)
  - v. Calculate the energy lost by the capacitor between  $T_1$  and  $T_2$ . (2)
  - vi. Calculate the time it took the ball to fall through the height of 0.5 m. (4)
  - vii. Sketch a graph to show how the current flowing through the resistor varies with time during the discharging process. Clearly label the maximum current and the time constant. (2)
  
- b. In an attempt to improve the accuracy of the experimental setup, another two capacitors are added as shown in Figure 8. Calculate the total capacitance of the circuit and explain how this will improve the accuracy of the experiment or otherwise. (3)

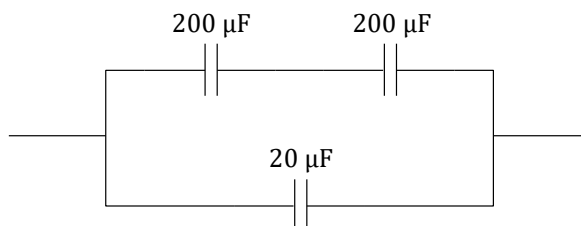

Figure 8

**(Total: 20 marks)**

13. A car's rubber tyre is used as the seat in a swing. The tyre is tied to a rope that hangs from a tree branch. The tyre is pulled back slightly from its rest position and released to perform simple harmonic motion.

- a. State the conditions that must be satisfied for an oscillatory motion to be considered as simple harmonic motion. (2)
- b. The velocity-time graph for the swing's seat is shown in Figure 9. Assume that there are no energy losses.

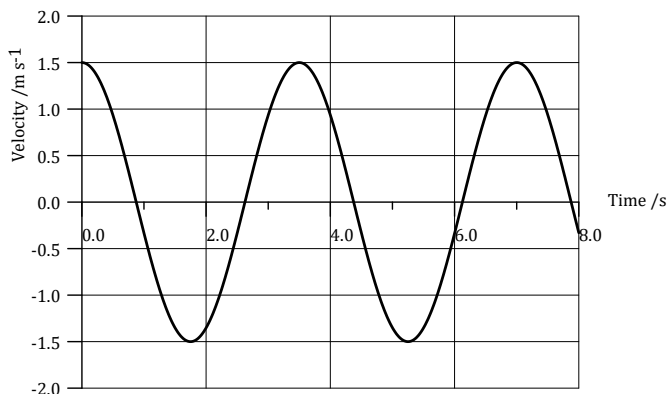

Figure 9

- i. From the graph determine the period of oscillation of the swing. (1)
- ii. Show that the mathematical representation of the graph in Figure 9 is given by  $v = 1.5 \cos(1.795t)$ . (3)
- iii. Show that the maximum displacement of the motion is 0.836 m and hence write down the mathematical representation of the displacement from equilibrium position as a function of time. (3)
- iv. Calculate the magnitude of the maximum acceleration of the seat, and state where this occurs. (2)
- v. If the mass of the tyre is 4.6 kg, calculate the total energy of the tyre. (2)
- vi. Show that the potential energy at displacement  $y$  from equilibrium position is given by  $PE = \frac{1}{2}m\omega^2y$ . (3)
- vii. At one point during the oscillatory motion of the tyre, the potential energy possessed by the tyre becomes equal to its kinetic energy. Determine the displacement from equilibrium position where this occurs. (2)
- viii. How would you measure the potential energy of the seat from a graph of restoring force against displacement from the centre of oscillation? (2)

**(Total: 20 marks)**

14. Faraday's and Lenz's laws are used to describe electromagnetic induction.

- a. State Faraday's law of electromagnetic induction and write down its mathematical representation. Define all the symbols used. (4)
- b. Describe an experiment to verify Lenz's law. The description should include:
  - i. a list of equipment and materials to be used; (1)
  - ii. a labelled diagram of the set-up; (2)
  - iii. a brief description of the procedure to follow; (3)
  - iv. a qualitative description of the observations recorded. (2)

**Questions continue on next page.**

- c. A physics teacher rides a bike to work. The front wheel of the bike has a dynamo attached to it. A simple mechanical gesture positions the dynamo in touch with the tyre of the front wheel so that the shaft of the dynamo rotates without slipping. The dynamo is the alternating current source used to light the headlamp of the bike. The dynamo has a circular coil with 150 turns of wire and a radius of 0.02 m. The coil rotates inside a magnetic field of 0.20 T and generates a sinusoidal voltage with a peak value of 4.2 V.
- Calculate the angular velocity with which the armature of the dynamo rotates and convert this to revolutions per minute. (3)
  - Calculate the root mean square voltage of the sinusoidal alternating voltage. (2)
  - The radius of the shaft of the generator in contact with the wheel is 1.0 cm. Determine the tangential speed with which the shaft of the generator must move to supply the e.m.f. of 4.2 V. (2)
  - Hence, state the tangential speed of the tyre. Explain your answer. (1)

**(Total: 20 marks)**

15. When two waves travel through a medium, their combined effect can be found by the Principle of Superposition.

- State the Principle of Superposition. (2)
- Melde's experiment is used to demonstrate standing waves as well as to investigate how the length of a wire  $L$ , its mass per unit length  $\mu$  and the tension in the wire  $T$  affect the frequency of the harmonics formed. Describe how this experiment can be used to investigate how the frequency of vibration varies with the length of the wire. The description should include:
  - a list of equipment and materials to be used; (1)
  - a labelled diagram of the set-up; (2)
  - a description of the procedure and measurements that need to be taken; (2)
  - a table of results; (2)
  - a sketch of the graph expected to be obtained from the results; (2)
  - a description of any calculations that need to be carried out. (2)

c. A monochromatic light source  $S$  of wavelength 690 nm is used to illuminate two slits  $A$  and  $B$  as shown in Figure 10.

- Sketch a graph that shows how the intensity of light on the screen varies from  $P$  to  $O$  to  $Q$ . Clearly indicate the position of  $O$  on the pattern drawn. (3)
- What kind of interference would one expect to find at position  $O$ ? Explain your answer. (1)
- The screen is 3.30 m away and the distance between first bright fringes on either side of the centre of the pattern are 1.80 cm apart. Determine the distance between the slits. (3)

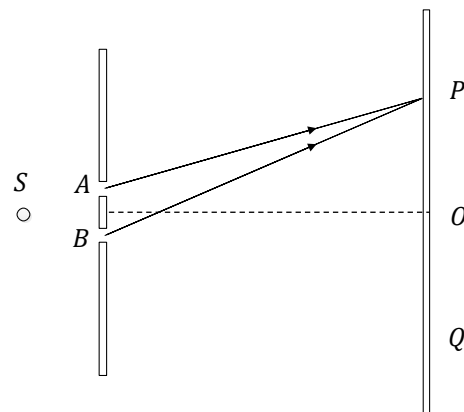

Figure 10

**(Total: 20 marks)**





---

SUBJECT:	<b>Physics</b>
PAPER NUMBER:	III
DATE:	31 <sup>st</sup> August 2022
TIME:	9:00 a.m. to 10:35 a.m.

---

**Experiment:** Determining the density of a liquid through two different methods.

**Apparatus:** Large beaker filled with liquid of unknown density, boiling tube, small weights, lead shot, wax, paper with printed scale and stopwatch.

**Diagram:**

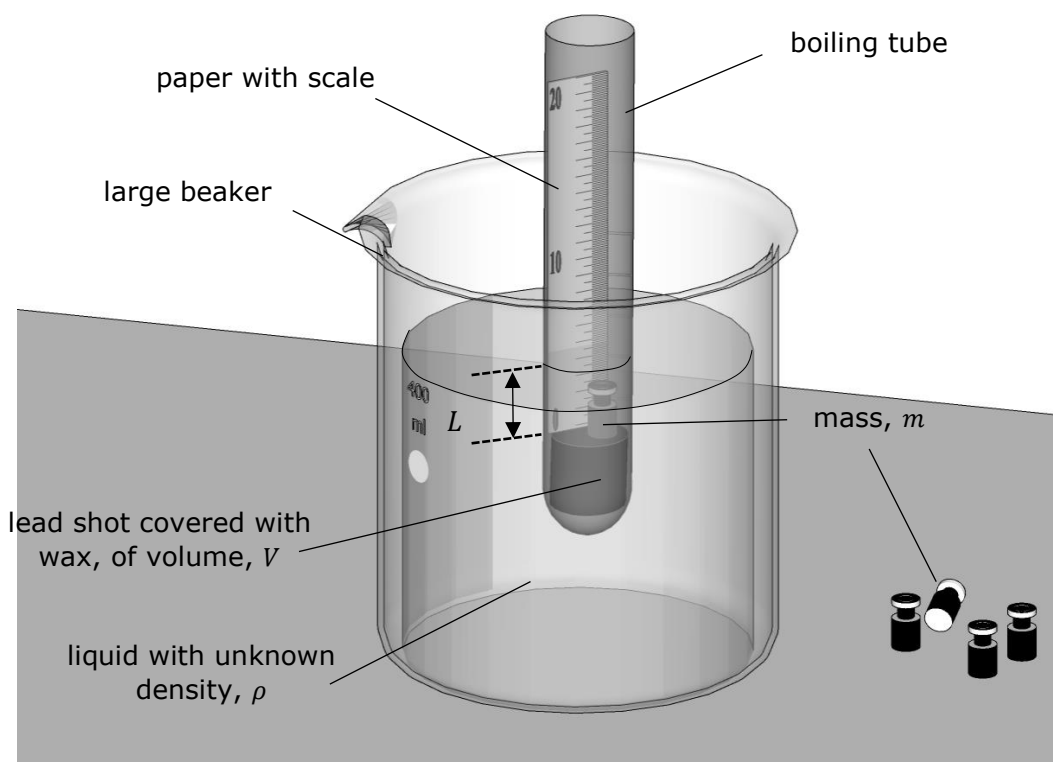

Figure 1: The experimental setup

### Method – Part A:

1. The apparatus shown in Figure 1 is set up.
2. The boiling tube is to be set floating vertically inside the large beaker. A quantity of lead shot is added to the bottom of the boiling tube and molten wax is used to hold them in place. The volume of molten wax poured covers the lead shot and fills the lowermost portion of the tube of volume  $V$ .

- 
3. A paper strip with a scale on it is attached to the inner surface of the boiling tube. The 0 cm mark on the paper strip is touching the surface of the wax, thus marking the beginning of the scale.
4. The large beaker is then filled with a liquid solution so that the boiling tube partially floats in it and is in equilibrium.
5. State Archimedes' principle.

---

---

---

---

(3)

6. A small mass  $m$  is added inside the boiling tube and the length of the submerged cylindrical part of the boiling tube is now  $L$ . Show that the upthrust force acting on the boiling tube is given by  $(V + AL)\rho g$  where  $V$  is the volume of the portion of the tube filled with wax,  $A$  is the cross-sectional area of the boiling tube and  $\rho$  is the density of the surrounding liquid.

---

---

---

---

(4)

7. The following are a few outcomes from scenarios that one can test using the experimental setup provided. Underline **ALL** situations that are **incorrect**.
- Increasing the mass inside the boiling tube will result in an increase in length of the submerged portion of the boiling tube.
  - Using a wider measuring cylinder will decrease the length of the submerged portion of the boiling tube.
  - If the liquid is replaced with one having a lower density, the portion of the boiling tube that is below the surface of the liquid will decrease.
  - Using a taller measuring cylinder will greatly affect the length of the submerged portion of the boiling tube.
- (3)

8. The diameter  $d$  of the boiling tube is measured at three different positions along the length of the tube. The data recorded is shown in Table 1.

Table 1

	$d_1 / \text{mm}$ $\pm 0.1 \text{ mm}$	$d_2 / \text{mm}$ $\pm 0.1 \text{ mm}$	$d_3 / \text{mm}$ $\pm 0.1 \text{ mm}$	$\bar{d} / \text{mm}$	$\bar{d} / \text{m}$
Diameter of Boiling Tube	24.7	24.7	25.1		

9. Small masses  $m$  are added inside the boiling tube and the length  $L$  of the submerged cylindrical portion of the tube is measured from the paper scale. Values of  $m$  and  $L$  are recorded in Table 2.

Table 2

$m / \text{kg}$ $\pm 0.001 \text{ kg}$	$\frac{m}{A} / \text{kg m}^{-2}$	$L / \text{m}$ $\pm 0.001 \text{ m}$
0.005		0.019
0.010		0.025
0.015		0.036
0.020		0.045
0.025		0.051
0.030		0.059
0.035		0.064

10. It is known that the relationship between  $m$  and  $L$  is given by

$$L = \left(\frac{m}{A}\right)\left(\frac{1}{\rho}\right) + \frac{1}{A}\left(\frac{M}{\rho} - V\right)$$

where  $M$  is the mass of the boiling tube with lead shot and wax only.

11. Work out the average value of the diameter of the boiling tube  $\bar{d} / \text{mm}$  and convert it to meters in the fifth and sixth column of Table 1 respectively. (2)

12. Calculate the cross-sectional area  $A$  of the boiling tube.  $[A = \frac{\pi(\bar{d})^2}{4}]$   
 \_\_\_\_\_ (2)

13. Work out the values of  $\frac{m}{A} / \text{kg m}^{-2}$  in the second column of Table 2. (7)

14. Plot a graph of  $L / \text{m}$  on the y-axis against  $\frac{m}{A} / \text{kg m}^{-2}$  on the x-axis. (10)

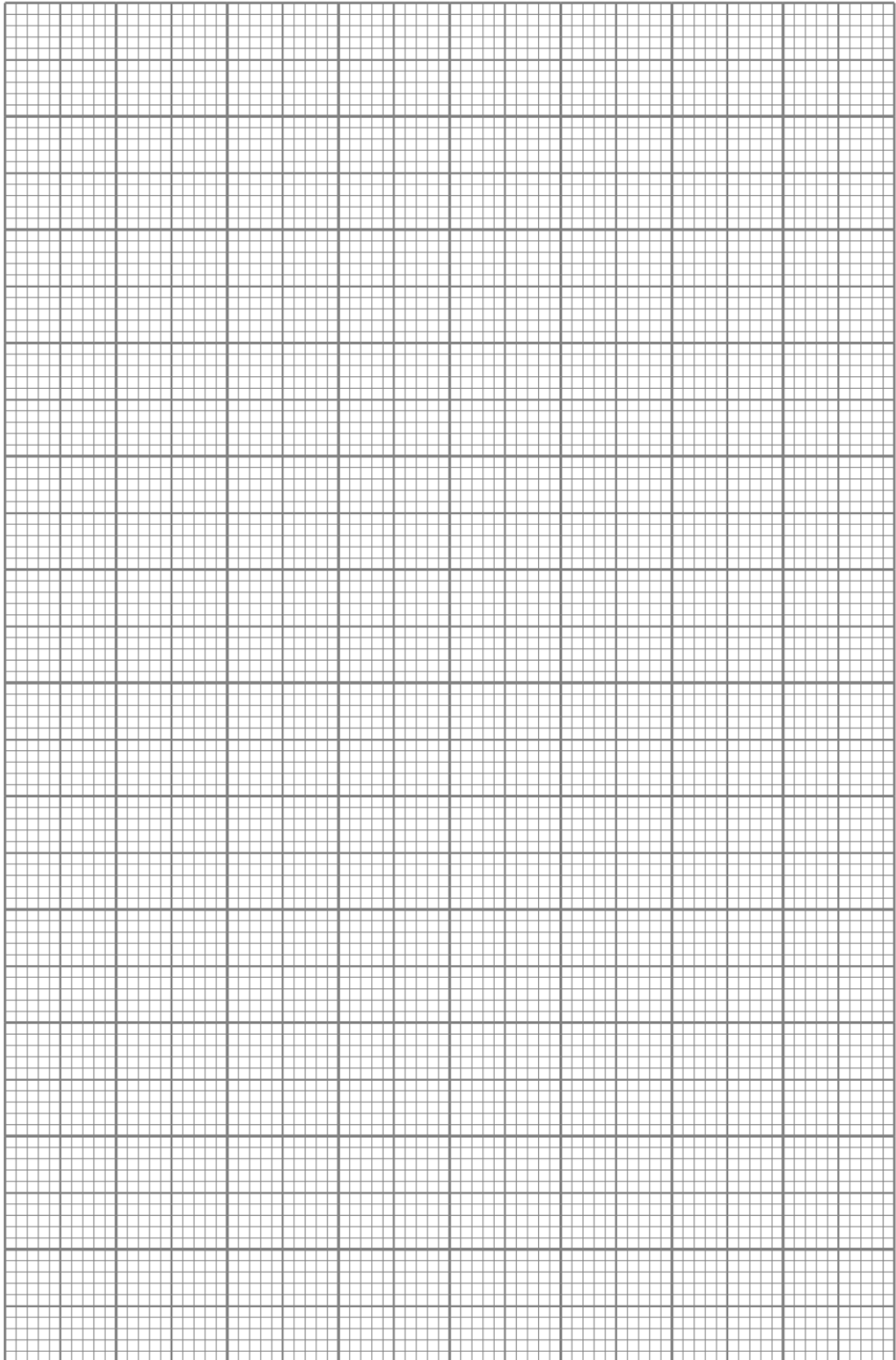

15. Use the graph to determine a value for the density  $\rho$  of the liquid.

---

---

---

---

(5)

16. If the mass  $M$  of the tube with lead shot and wax only is 0.012 kg, use the graph to calculate the volume of wax in the lowermost portion of the boiling tube.

---

---

---

---

(5)

**Method – Part B:**

17. In this part of the experiment, the density of the liquid,  $\rho$ , will be determined through another method that involves the oscillations of the same partially loaded boiling tube.

18. The boiling tube of mass  $M$  and with a mass  $m$  inside is given a downward push and is left to oscillate up and down in the liquid, as shown in Figure 2. The time taken for the boiling tube to complete 20 oscillations is measured using a stopwatch.

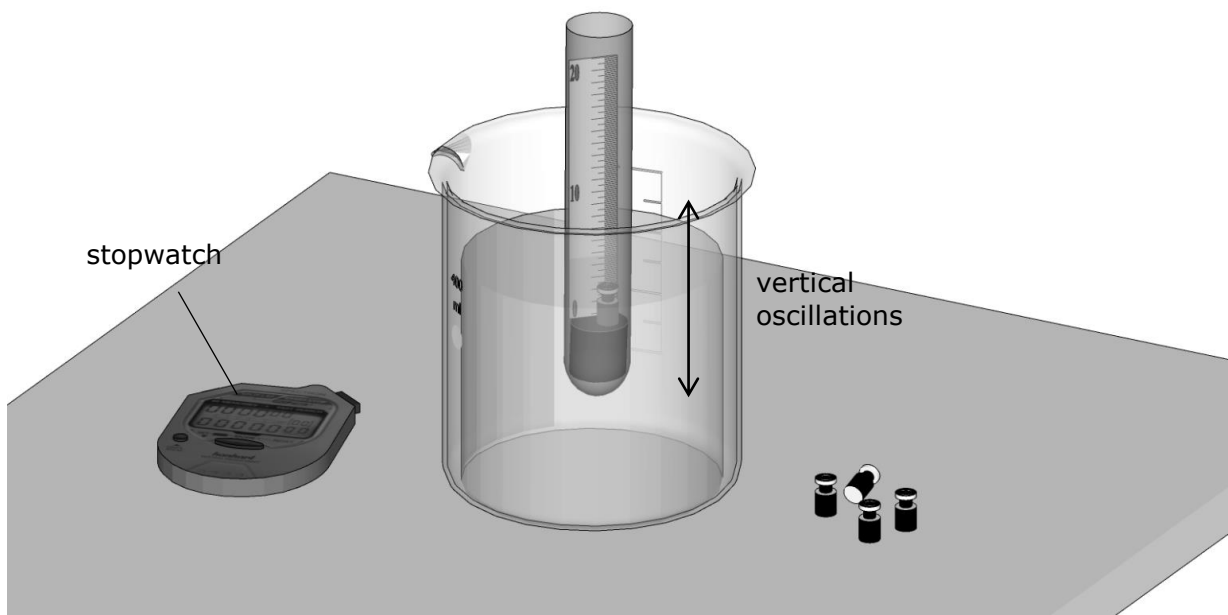

Figure 2

19. Table 3 shows the data recorded. For every mass,  $m$ , listed in the first column, the time  $T_{20}$  /s taken for the boiling tube to complete 20 oscillations is recorded.
20. The period of oscillations  $T$  is related to the mass placed inside the boiling tube by the equation

$$T = 2\pi \sqrt{\frac{M + m}{\rho Ag}}$$

where the symbols in the equation have the same definition used in part A.

Table 3

$m$ /kg $\pm 0.001$ kg	$T_{20}$ /s	$T$ /s	$T^2$ /s <sup>2</sup>
0.010	7.6		
0.020	8.7		
0.030	10.3		
0.040	11.5		
0.050	12.5		
0.060	13.8		
0.070	14.1		

21. Explain how a graph of  $T^2$  against  $m$  will enable one to determine another value for the density of the liquid.

---



---



---



---

(3)

22. Complete Table 3 by working out the missing values of  $T$  /s and  $T^2$  /s<sup>2</sup>. (14)

23. Plot a graph of  $T^2$  on the y-axis against  $m$  on the x-axis. (10)

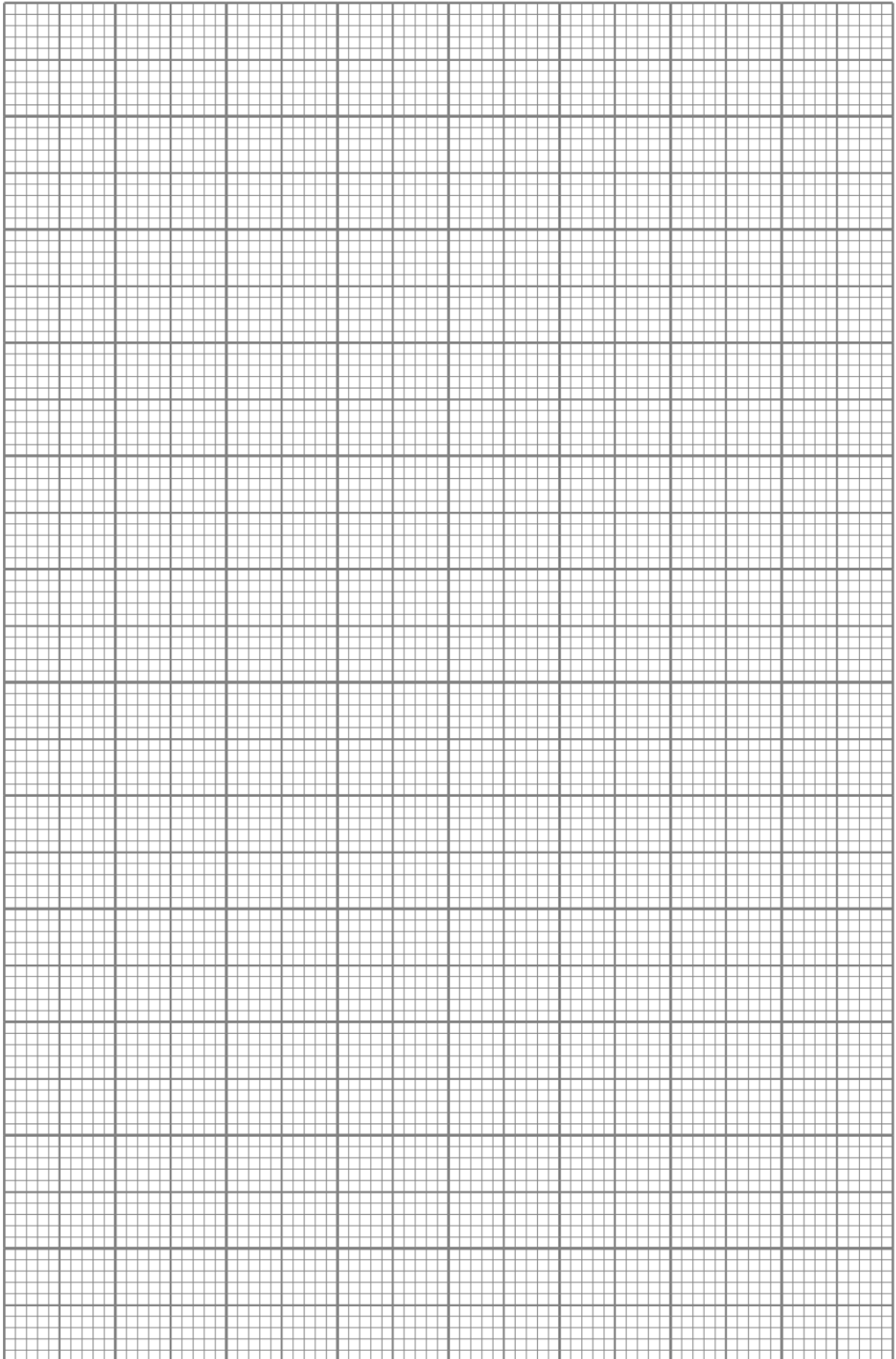

---

24. Use the graph to obtain another value for the density of the liquid  $\rho$ .

---

---

---

---

---

---

(5)

25. Use the graph to verify that the value of  $M$  that was given in part 16 was indeed correct.

---

---

---

---

(4)

26. Calculate an average value for  $\rho$ .

---

---

---

---

(1)

27. State **ONE** source of error and **ONE** corresponding precaution that could be taken to improve the setup or the procedure.

---

---

---

---

---

(2)