

MATRICULATION AND SECONDARY EDUCATION CERTIFICATE EXAMINATIONS BOARD  
UNIVERSITY OF MALTA, MSIDA  
MATRICULATION EXAMINATION  
INTERMEDIATE LEVEL  
SEPTEMBER 2016

---

<b>SUBJECT:</b>	ENGINEERING DRAWING AND GRAPHICAL COMMUNICATION
<b>DATE:</b>	31st August 2016
<b>TIME:</b>	9:00 a.m. to 12:05 p.m.

---

**Directions to Candidates**

Write your **index number** where indicated **at the top** of **all** Drawing Sheets.

Only scientific calculators may be used. Programmable calculators are **NOT** allowed.

Unless otherwise stated:

- B.S. or equivalent (ISO) recommendations should be adopted throughout your answers;
- all dimensions are in millimetres, unless otherwise stated;
- all answers are to be accurately drawn with instruments;
- all construction lines must be left in each solution;
- drawing aids may be used.

**Dimensions not given should be estimated.**

Careful layout and presentation are important.

Marks will be awarded for accuracy, clarity and appropriateness of constructions.

Colour/shading may be used where appropriate.

**Section A:** Attempt any **FOUR** questions from five.

**Section B:** Attempt any **ONE** question from two.

**Section C:** Attempt any **ONE** question from two.

**SECTION A**

Attempt only **FOUR** questions from this section.

**Question 1**

A photograph and a sketch of a clear glass decanter is shown in Figure 1a. The elevation of the upper part of the decanter is designed as follows:



- a) Curve A is the locus of the point P on the circumference of a 60 mm diameter circle, which rolls without slipping for half a revolution downwards on line M-N. Trace the locus of the point P and name the curve traced.
- b) Curve B, the lip of the decanter, is the locus of the point Q situated on a 100 mm diameter as a 60 mm diameter circle rolls without slipping for half a revolution upwards on line S-T. Trace the locus of point Q and name the curve traced.
- c) Curve C, is the locus of the point R situated on a 50 mm diameter as a 60 mm diameter circle rolls without slipping for half a revolution upwards on line U-V. Trace the locus of point R and name the curve traced.

(13 marks)

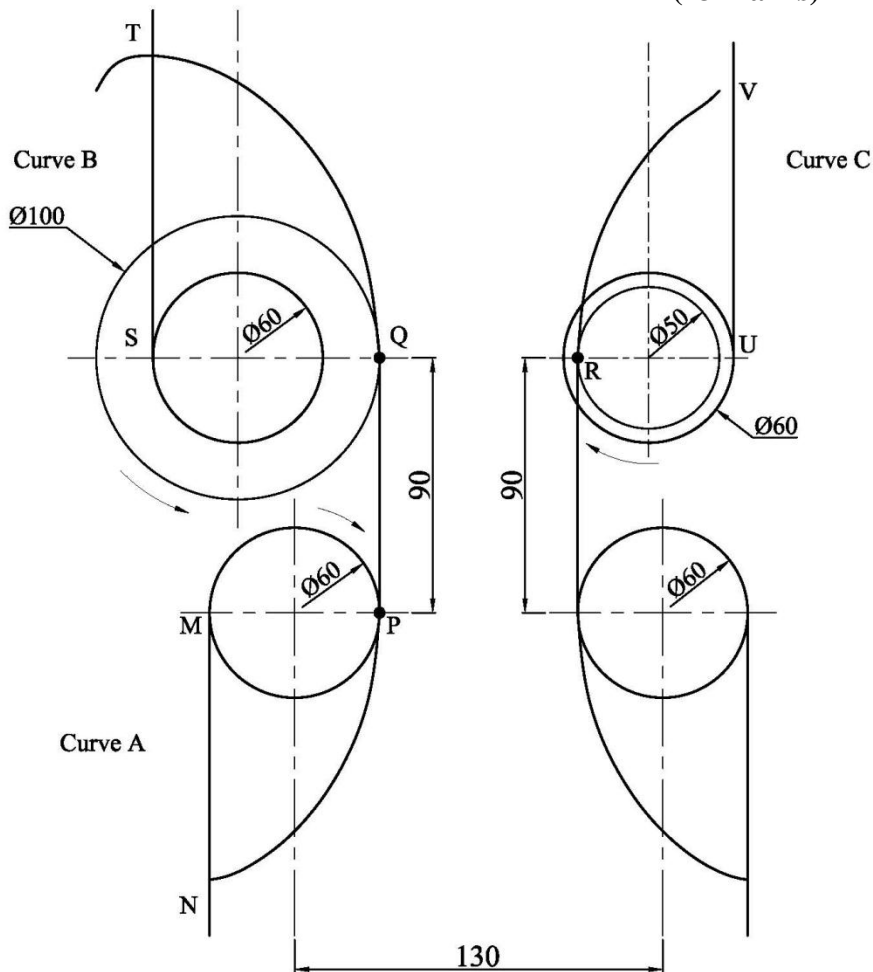

FIG. 1b

FIG. 1a

**Question 2**

Part of a drainpipe in a yard, is illustrated in Figures 2a. Water is diverted to the horizontal pipe by means of an inverted square pyramid. Copy, full size, Figure 2b and by using a suitable method show the curves of intersection between the inverted square pyramid and cylinder. **Show the curves of intersection on the Front View only.** Include any hidden detail.

(13 marks)

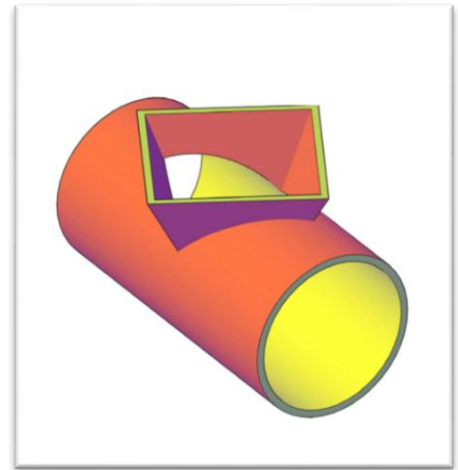

FIG. 2a

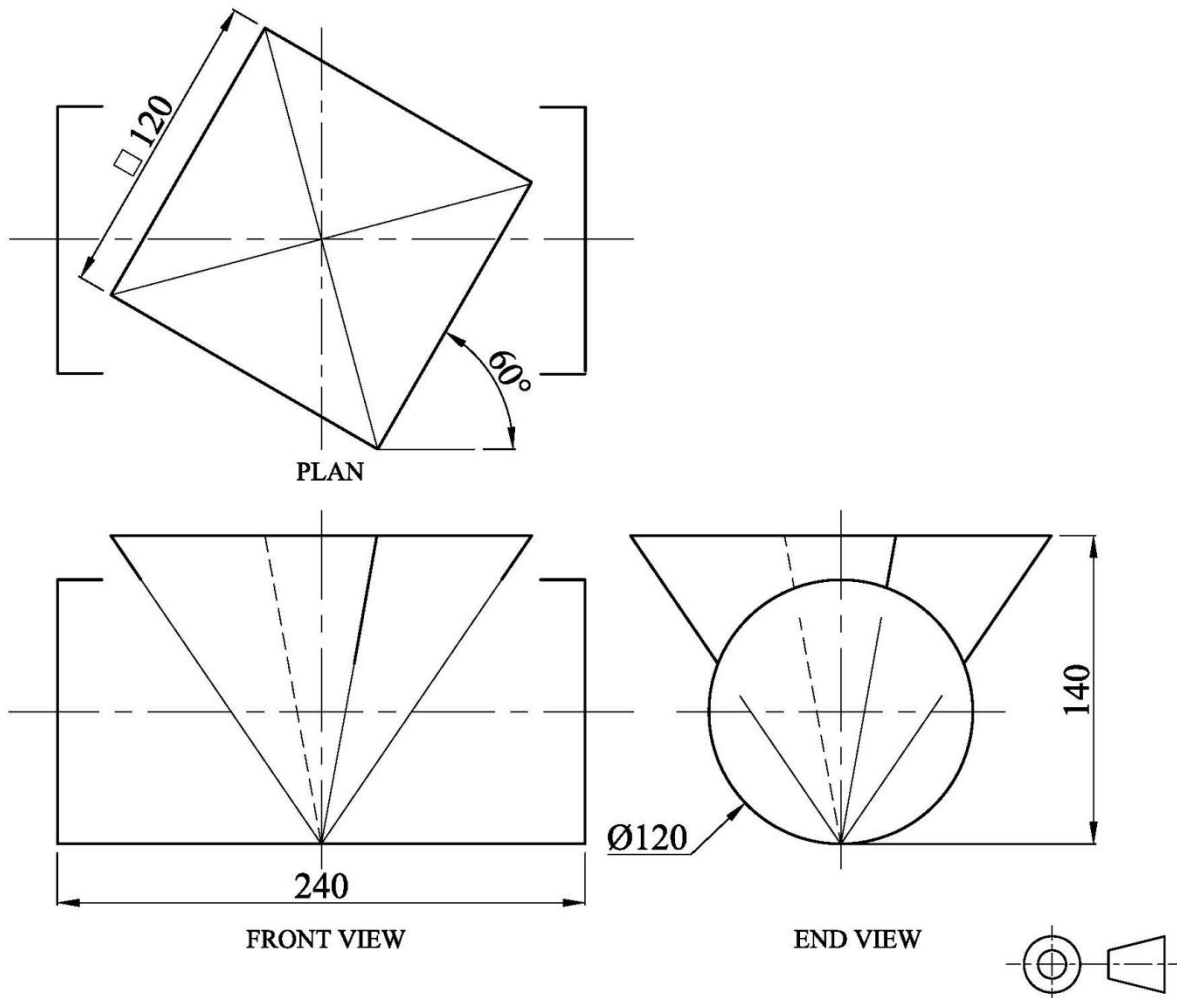
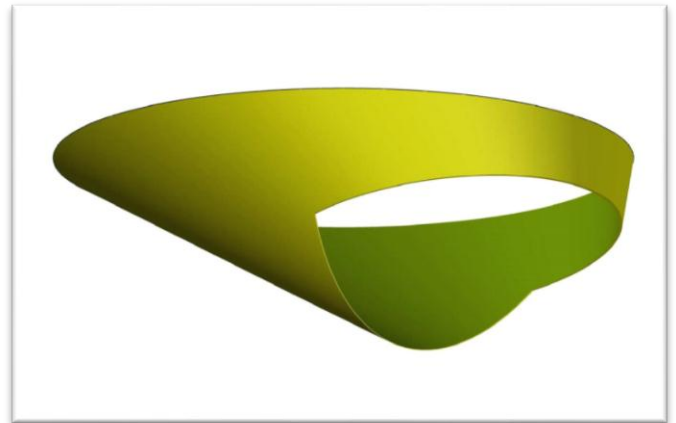

FIG. 2b

**Question 3**

The oblique cone illustrated in Figure 3a is open at both ends. Figure 3b is the front view of the oblique cone with a part hexagonal cut. The centre of the regular hexagon is on the apex of the oblique cone and two sides of the hexagon cut the oblique cone as shown in Figure 3b.



Construct to full size:

- a) the given elevation shown in Figure 3b;
- b) the plan of the oblique cone with the cut;
- c) the true length diagram showing neatly the necessary true lengths;
- d) half surface development of the oblique cone.

FIG. 3a

**(13 marks)**

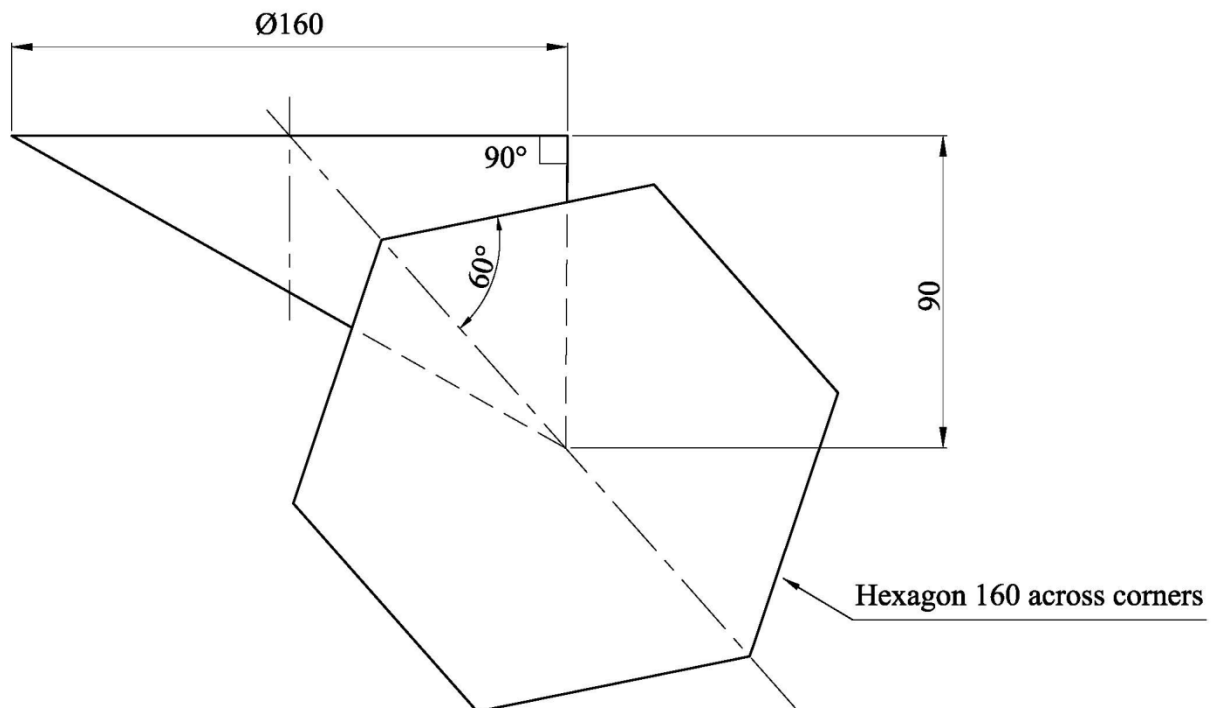

FIG. 3b

**Question 4**

Figure 4a, shows a jib crane, hinged to a vertical tower swivelling crane at its lower end and supported in the position shown by a horizontal cable attached to the jib. The weight of the jib is 120 kN, carries a load of 80 kN at the end of the jib and another load of 160 kN at a distance of 2.5 m from the hinge. The length of the jib is 15 m.

- a) To a scale of 10 mm representing 1 m, copy Figure 4b.
- b) Using a scale of 10 mm representing 20 kN, draw a polar diagram and a link polygon to determine the position of the resultant of the three forces. Indicate the point of intersection of the resultant with the horizontal cable and state the horizontal distance from point T.
- c) Use the triangle of forces principle to determine:
  - i. reaction in the horizontal cable;
  - ii. reaction at the hinge;
  - iii. indicate the direction of each reaction.

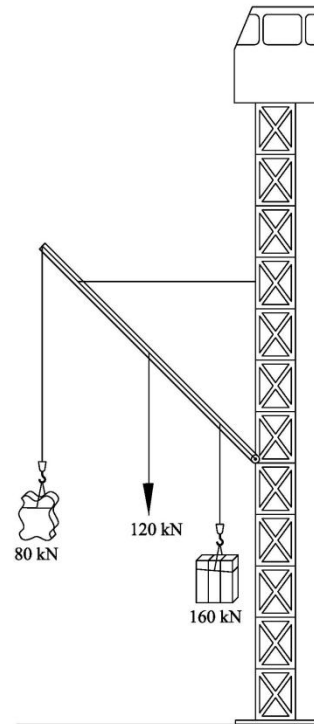

FIG. 4a

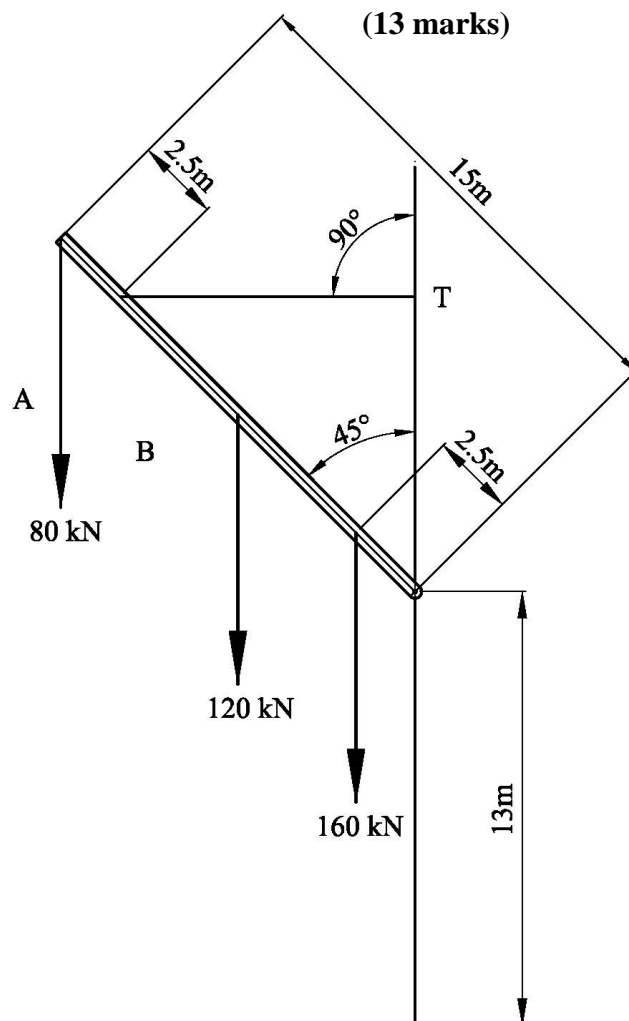

FIG. 4b

**Question 5**

Figure 5a shows a stairs winding around a newel (centre pole). A handrail on the outside is used for safety reasons. Part of the handrail is represented by the semi-circle in the plan shown in Figure 5b.

- Copy, full size, the given elevations shown in Figure 5b.
- Trace the locus of the vertical line PQ as it winds around and up the semi-cylinder, from PQ to RS (half a turn of the handrail). Name the curve representing half a turn of the handrail.
- Using neat projection and construction lines draw the surface development of the hand rail constructed in part b).

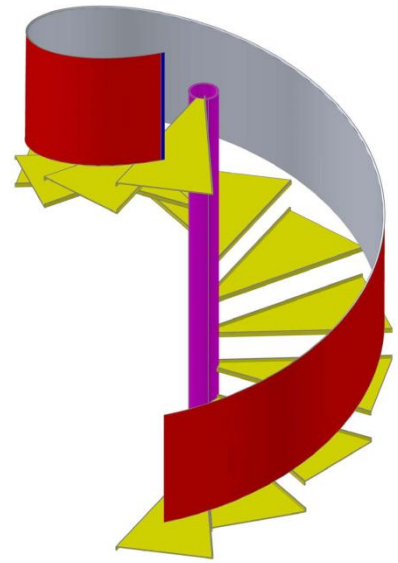

FIG. 5a

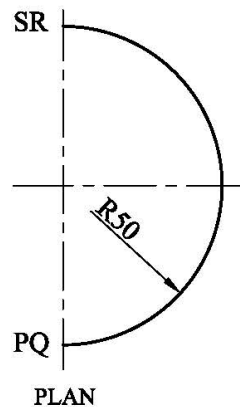
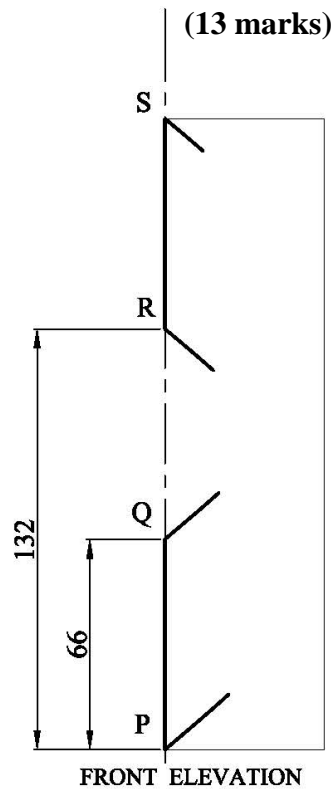

FIG. 5b

## SECTION B

Attempt only **ONE** question from this section.

### Question 6

A Marking Machine is illustrated in Figure 6a. Figure 6b on the attached A3 sheet shows detailed drawings of the various parts of the Marking Machine, which is to be assembled as follows:

- The 20 x 26 diameter cylindrical end of the die (item 2) is a press fit into the 26 mm diameter hole of base (item 1).
- The bush (item 3) is pressed into the 34 mm diameter hole of the frame (item 4). The frame is bolted to the base by four bolts (not shown).
- The wire spring (item 5) is assembled on the 26 mm diameter ram (item 6), the top end of the spring resting against the 40 mm diameter head of the ram.
- The ram complete with the spring, are inserted from the top end of the frame and the ram is a sliding fit into the 26 mm diameter hole of the bush.
- The M12 threaded portion of the marking punch (item 7) is securely screwed into the M12 threaded hole at the lower end of the ram.

Draw, full size, a sectional elevation of the Marking Machine, as indicated by the cutting plane A-A.

All fillet radii are 10 mm unless otherwise stated.

Point R marked on the ram is to be drawn 60 mm above the point F marked on the frame.

The spring is to be shown in a "schematic representation".

Do not show hidden details.

**(24 marks)**

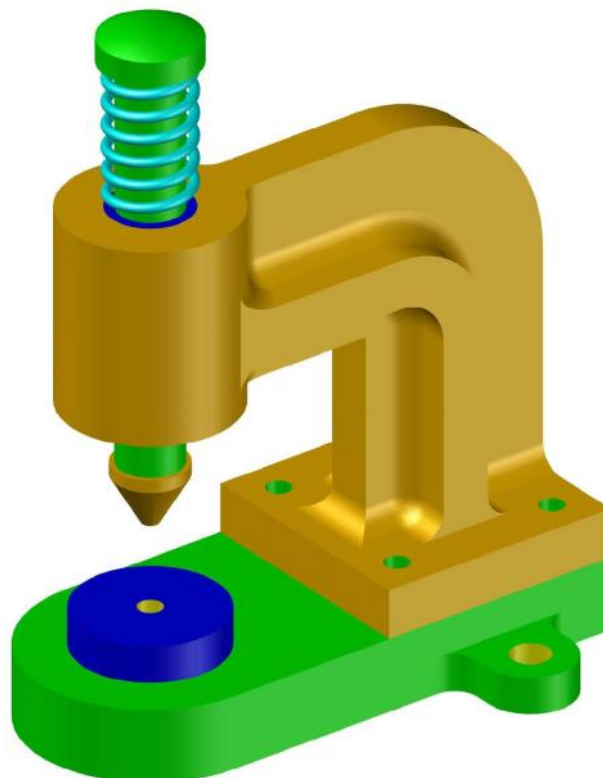

FIG. 6a

### Question 7

An illustration of a 'push-pull' mechanism is shown in Figure 7a. The lever P on the left hand side is connected to the bell crank by a countersunk screw and the lever Q on the right hand side is connected to the bell crank by a hexagonal bolt.

Using the dimensions given in Figure 7b:

- a) Draw the partial section elevation A – A on the left hand assembly, showing;
- the lever assembled on the bell crank end,
  - an elevation of a countersunk head screw above the assembly, having a 32 mm x 2 mm diameter head, a 24 mm diameter x 18 mm cylindrical portion and an M18 external threaded end, 26 mm in length.

When fitted in position the head of the countersunk screw is to be flush with the lever. The edge of the head screw may be flat or rounded but not sharp edged.

(12 marks)

- b) Draw an auxiliary elevation of the end of the right hand assembly showing;
- the partial sectional elevation B – B of the lever assembly on the bell crank end.
  - a suitable hexagonal bolt above the lever, having a hexagonal head 36 mm across the flats and 12 mm head thickness. A cylindrical portion 24 mm diameter x 24 mm in length and an M18 external thread, 26 mm in length.

(12 marks)

(24 marks)

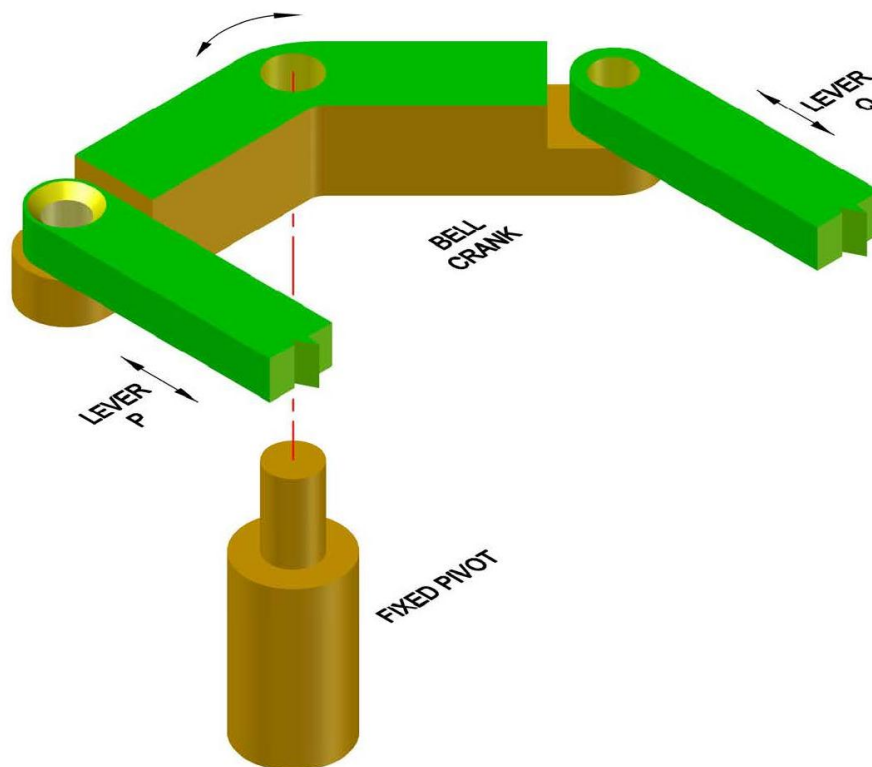

FIG. 7a



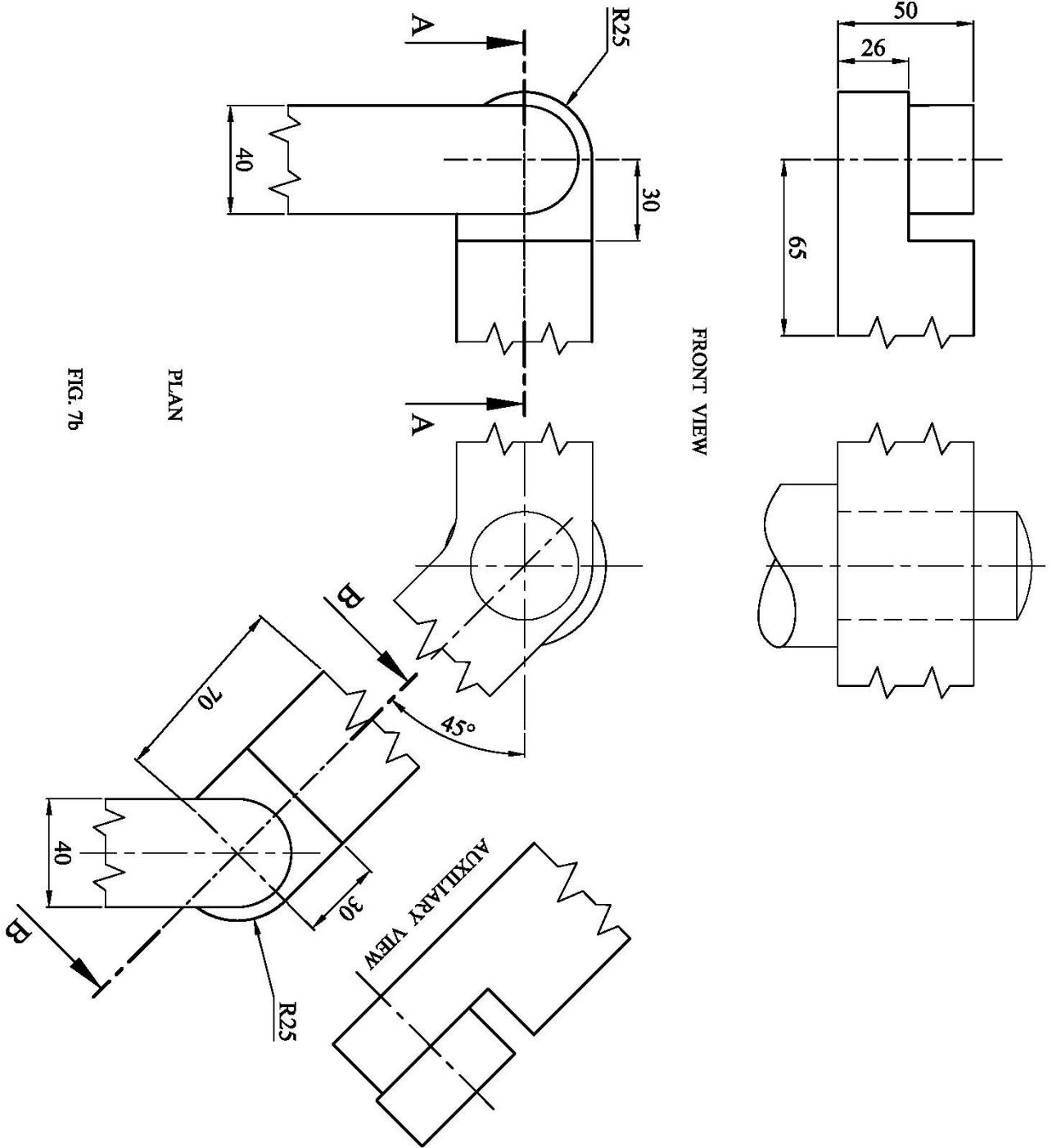

FIG. 7b

PLAN

FRONT VIEW

AUXILIARY VIEW

**SECTION C**

Attempt only **ONE** question from this section.

**Question 8**

Table 8a shows the results from a survey carried out in 2015 (reference year 2014) by the Malta National Statistics Office among 91 active band clubs in Malta and Gozo.

Table 8a.

District	Band club publications by type and district			
	Feast books	Magazines/leaflets	Videos/DVDs	Total
Southern Harbour	20	37	11	68
Northern Harbour	19	13	5	37
South Eastern	22	22	9	53
Western	12	32	4	48
Northern	7	5	3	15
Gozo and Comino	12	27	2	41
<b>Total</b>	<b>92</b>	<b>136</b>	<b>34</b>	<b>262</b>

Design a poster to show the results of the survey;

- Write the title of the poster: Band Clubs;
- Draw an isometric bar chart showing the number of band club publications (feast books, magazines/leaflets and Videos/DVD's) for each district. Label this bar chart 'Band club publications by Type and District';
- Draw a planometric pie chart showing the total band club publications for each district. Label this pie chart 'Band club publications by District'.

Poster design Tips:

- Use colour and shading to render the drawing;
- Make use of typography (fonts);
- Form an attractive presentation, clearly conveying the information.

**(24 marks)**

### Question 9

An isometric sketch showing the layout of a stage is shown in Figure 9a.

The plan and front view of the stage are shown in Figure 9b. The wooden stage features two poles for light fixtures, a large speaker on one side, and two speakers (monitors) pointing towards the performers to help them hear themselves on stage. The flooring on the stage and below it is made from square wooden tiles.

Using a scale of 60 mm representing one floor wooden tile and a scale of 27 mm representing one block from the pole, construct an estimated **single-point perspective** view of the stage.

*Notes:*

- *The viewing direction is indicated by the large arrows at the bottom of Figure 9b.*
- *The suggested vanishing point is indicated in Figure 9b.*
- *Design a backdrop (background) for your stage.*
- *Render your drawing to enhance the solution.*

**(24 marks)**

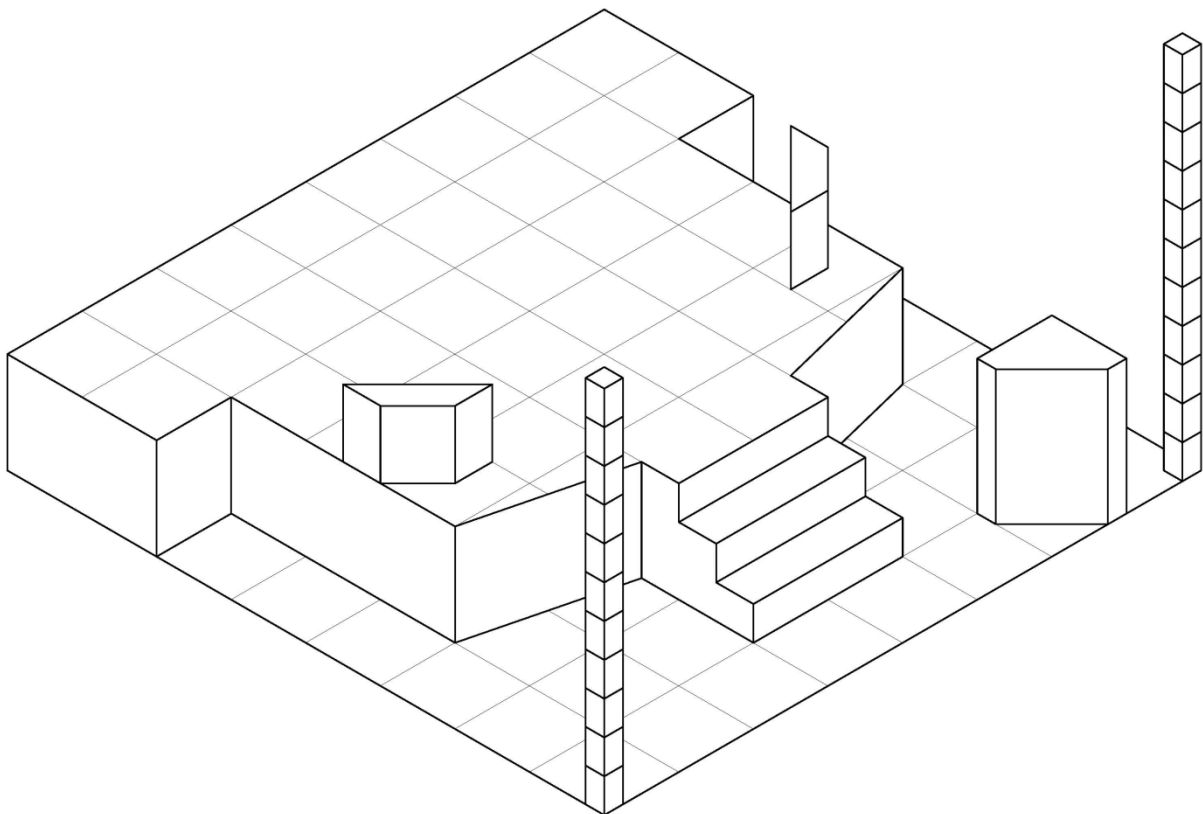

FIG. 9a

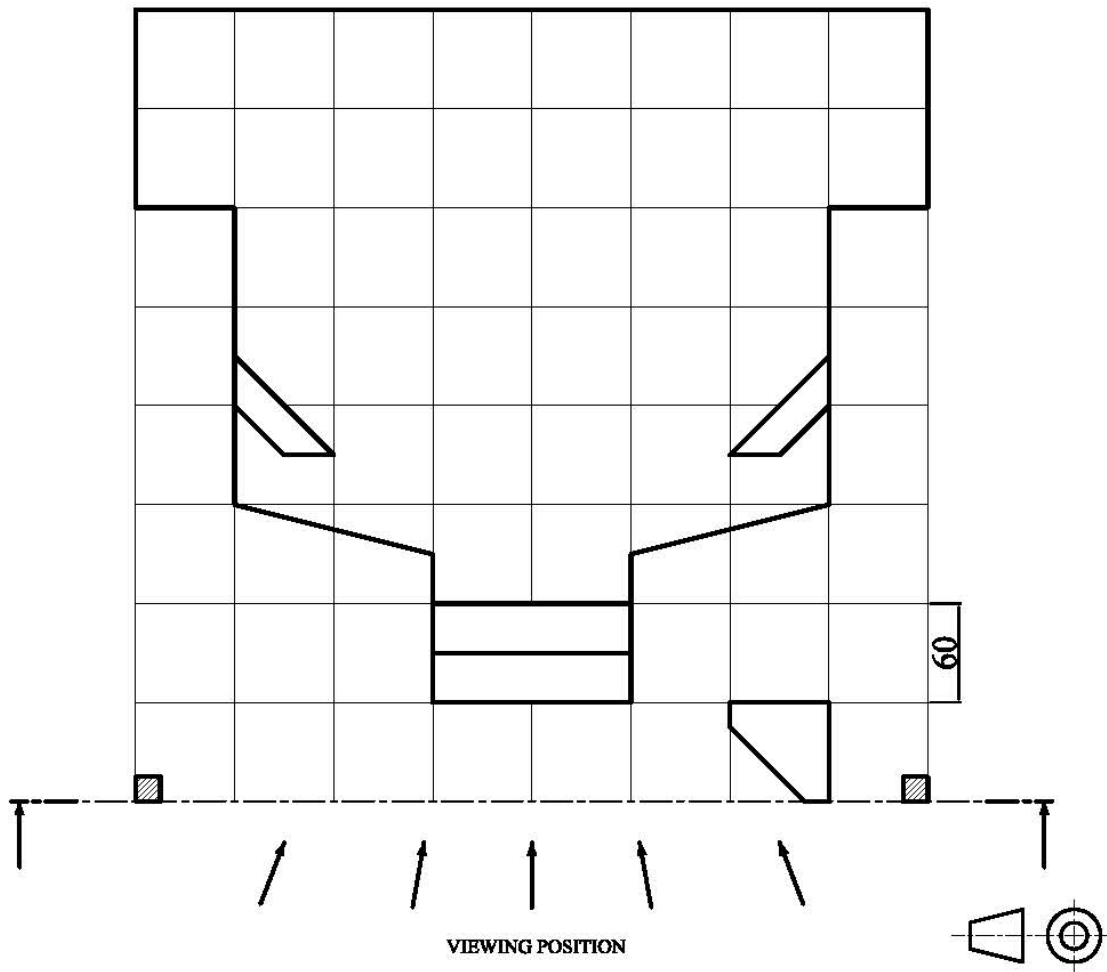
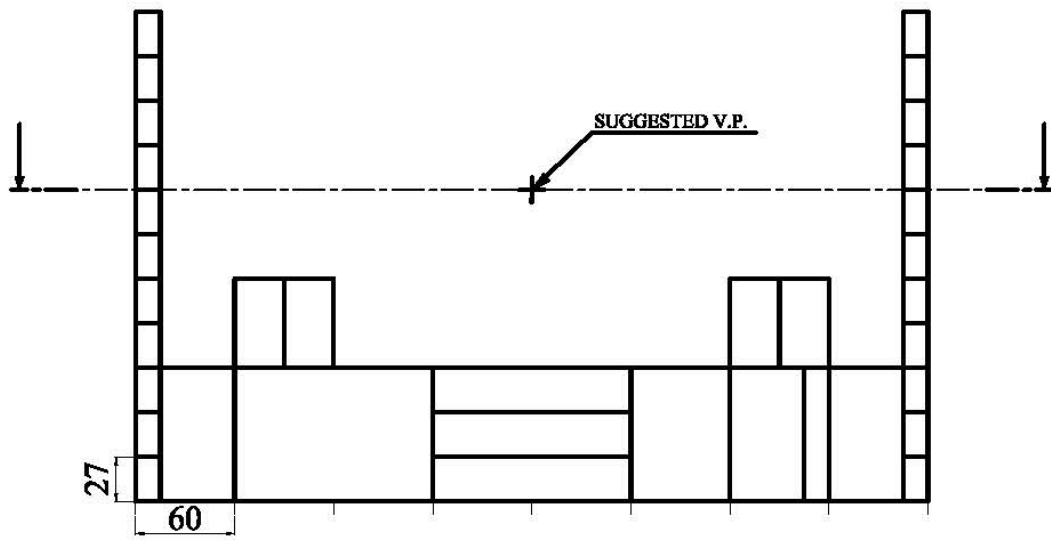
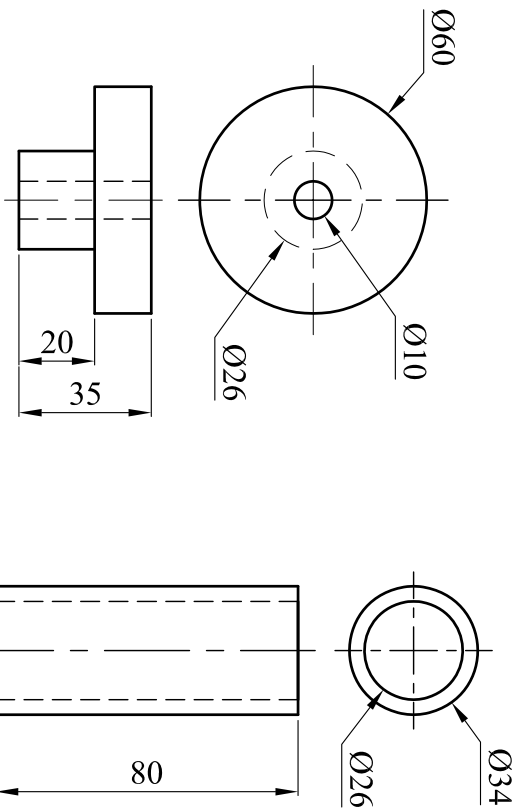
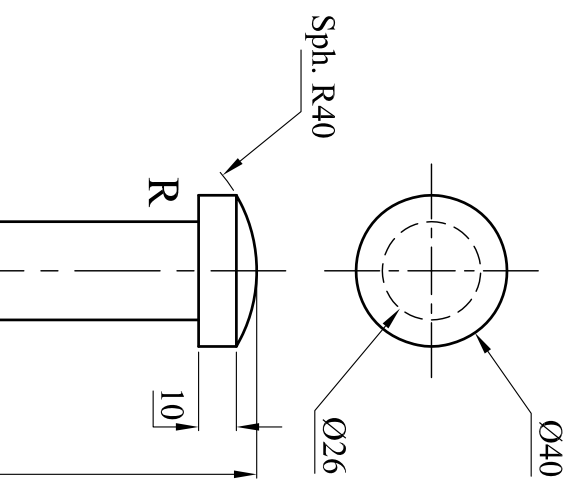

FIG. 9b



DIE (ITEM 2)

BUSH (ITEM 3)



RAM (ITEM 6)

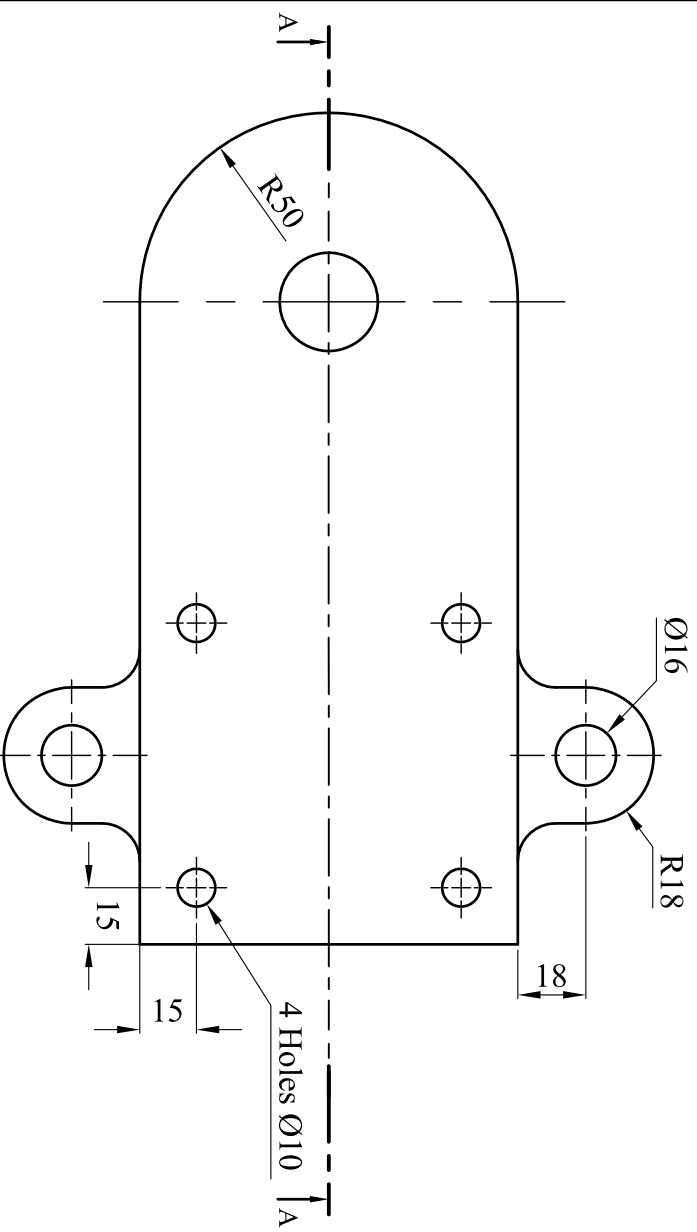

BASE (ITEM 1)

FILLET RADII 10mm unless otherwise stated

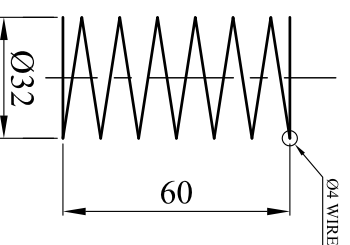
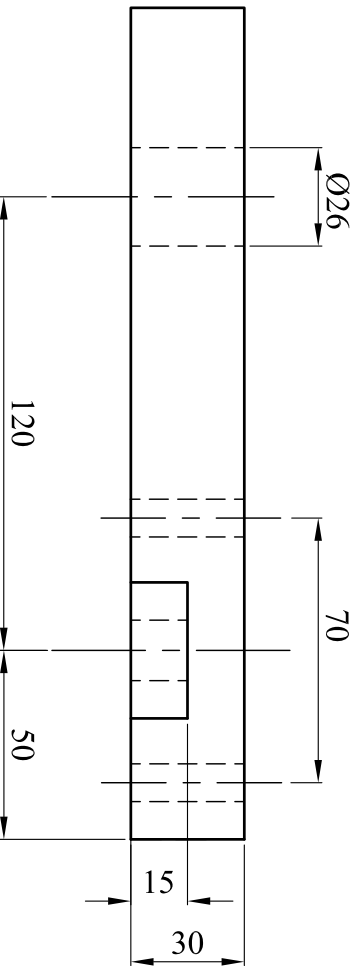

WIRE SPRING (ITEM 5)

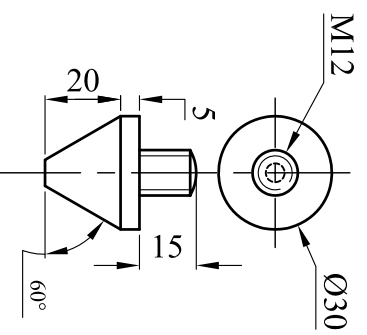

PUNCH (ITEM 7)

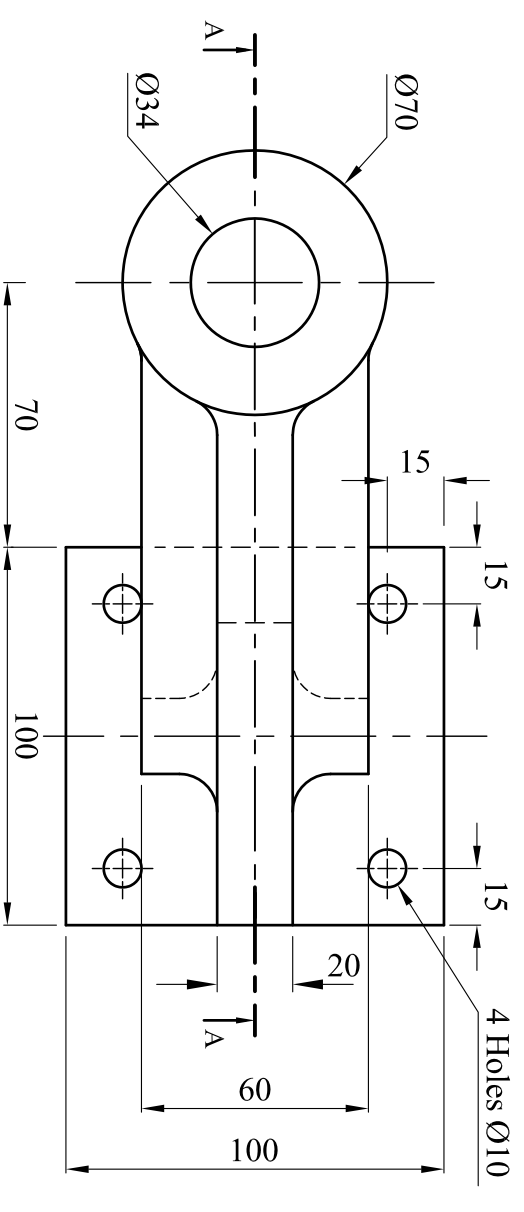

FRAME (ITEM 4)

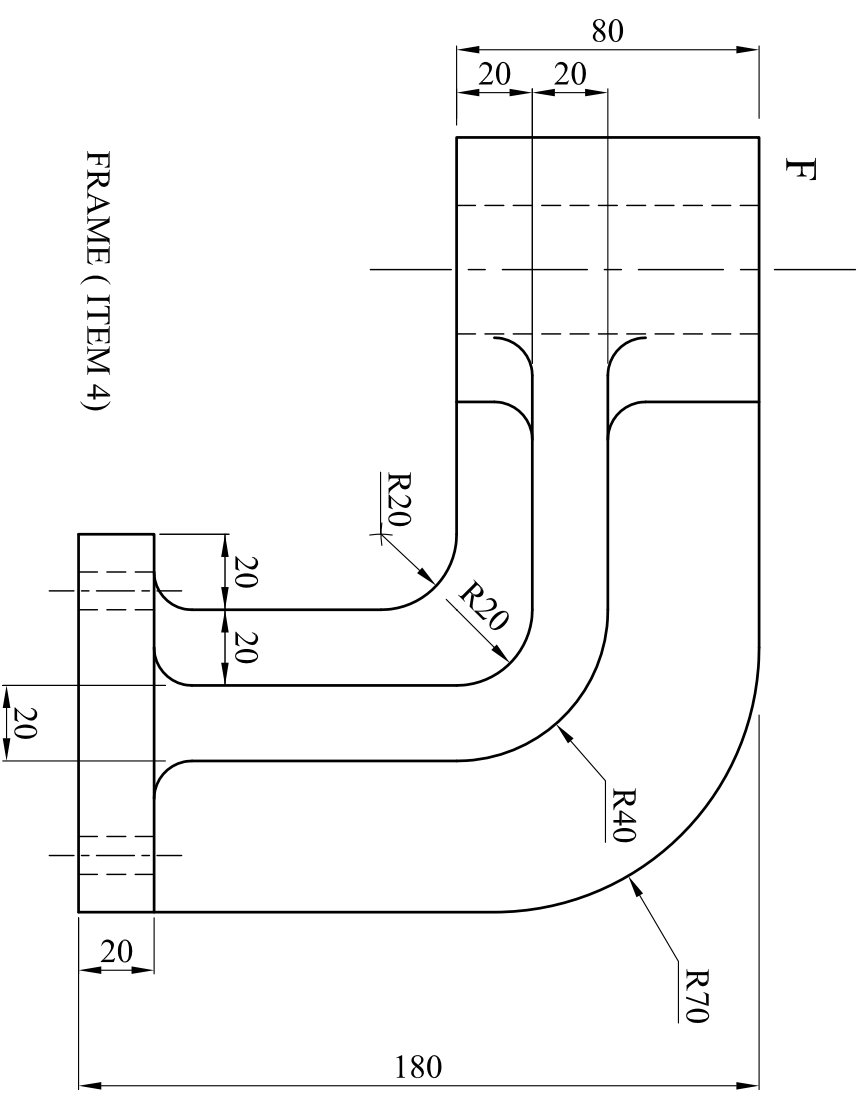

## MARKING MACHINE

