

MATRICULATION AND SECONDARY EDUCATION CERTIFICATE EXAMINATIONS BOARD
UNIVERSITY OF MALTA, MSIDA

MATRICULATION EXAMINATION
INTERMEDIATE LEVEL
MAY 2017

SUBJECT:	ENGINEERING DRAWING AND GRAPHICAL COMMUNICATION
DATE:	3 rd May 2017
TIME:	4:00 p.m. to 7:05 p.m.

Directions to Candidates

Write your index number where indicated at the top of all drawing sheets.

Only scientific calculators may be used. Programmable calculators are not allowed.

Unless otherwise stated:

- B.S. or equivalent (ISO) recommendations should be adopted throughout your answers;
- all dimensions are in millimetres, unless otherwise stated;
- all answers are to be accurately drawn with instruments;
- all construction lines must be left in each solution;
- drawing aids may be used.

Dimensions not given should be estimated.

Careful layout and presentation are important.

Marks will be awarded for accuracy, clarity and appropriateness of constructions.

Colour/shading may be used where appropriate.

Section A: Attempt any **FOUR** questions from five.

Section B: Attempt any **ONE** question from two.

Section C: Attempt any **ONE** question from two.

SECTION A

Attempt only **FOUR** questions from this section.

Question 1

A right octagonal pyramid with a vertical cylinder intersection is illustrated in Figure 1a.

- a) Copy, full size, a half plan of the octagonal pyramid and the cylinder shown in Figure 1b. (2)
- b) Construct and complete the front elevation of the octagonal pyramid and the vertical cylinder showing the curves of intersection. (8)
- c) Project an end elevation in the direction of the arrow X showing the curves of intersection on the pyramid and cylinder. (3)

(Total: 13 marks)

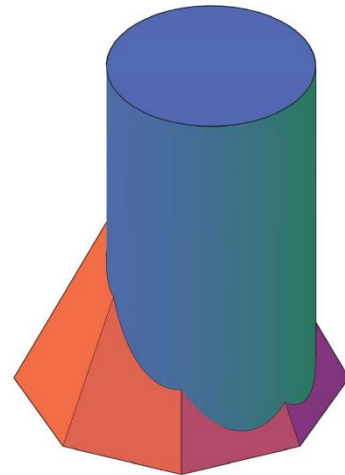

Figure 1a

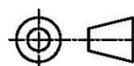
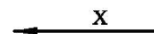
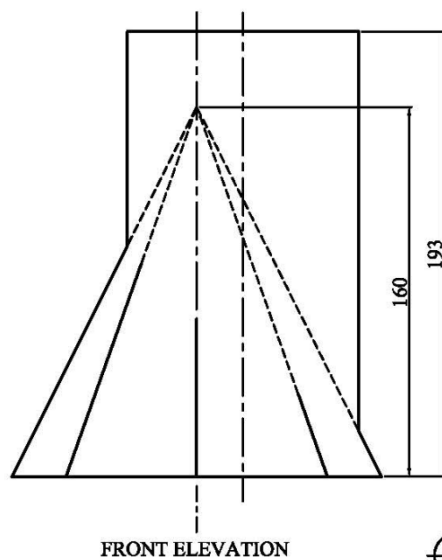
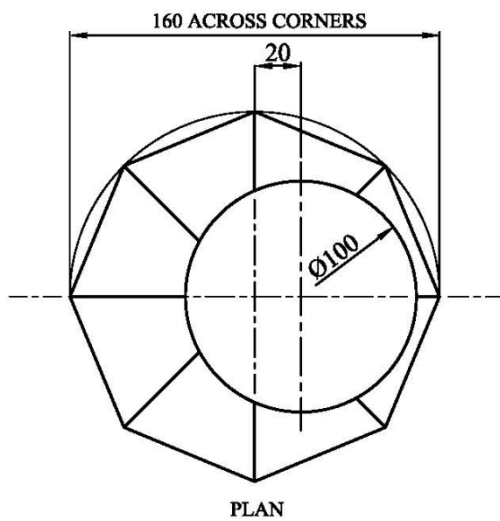

Figure 1b

Question 2

Liquid is diverted from a tapered tank through a funnel as illustrated in Figure 2a. The funnel is shaped and cut from an oblique cone as shown in Figure 2b.

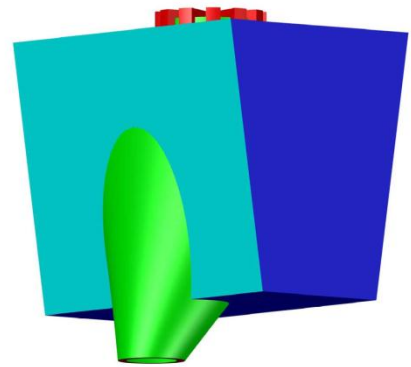

Figure 2a

- a) Copy the given elevation. (3)
- b) Draw and complete the half auxiliary plan. (3)
- c) Construct the necessary true lengths and draw a half surface development of the cut oblique cone. (7)

(Total: 13 marks)

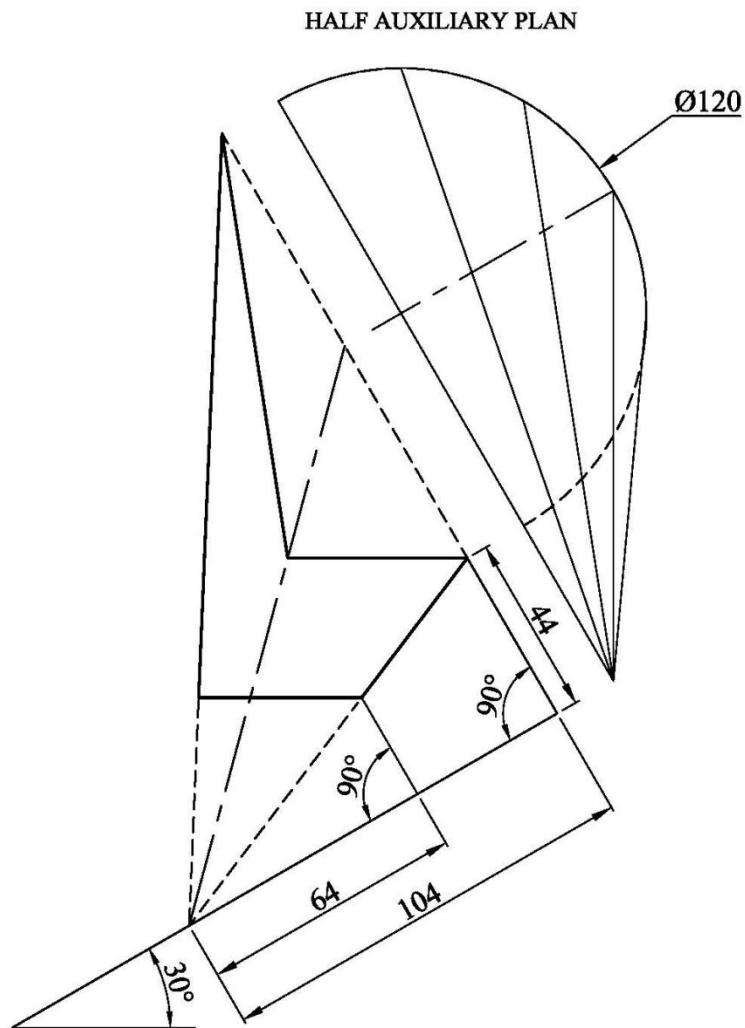

Figure 2b

Question 3

A cantilever supporting three vertical concentrated point loads is shown in Figure 3.

- a) Using a linear scale of 10 mm representing 1 m, a force scale of 15 mm representing 1kN, and a polar distance of 100 mm, construct graphically the shear force and bending moment diagrams for the cantilever. (10)
- b) Determine the:
- maximum bending moment; (1.5)
 - maximum shear force. (1.5)

(Total: 13 marks)

SPACE DIAGRAM

Figure 3

Question 4

An illustration of a gear wheel is shown in Figure 4a.

- a) Obtain the pitch circle diameter and the addendum of a spur gear with a module of 15, the number of teeth on the gear is 20 and the pressure angle is 20° . Construct a true involute profile of the spur gear with the given data. Place the pitch point P passing through the inclined centre line OA as shown in Figure 4b. Show all construction lines. (7)
- b) Using the gear formulae, obtain the dedendum, the circular pitch and the tooth thickness. Draw the tooth curve with the pitch point P intersecting the vertical centre line and complete **TWO** teeth of the gear. (4)
- c) Show all calculations. (2)

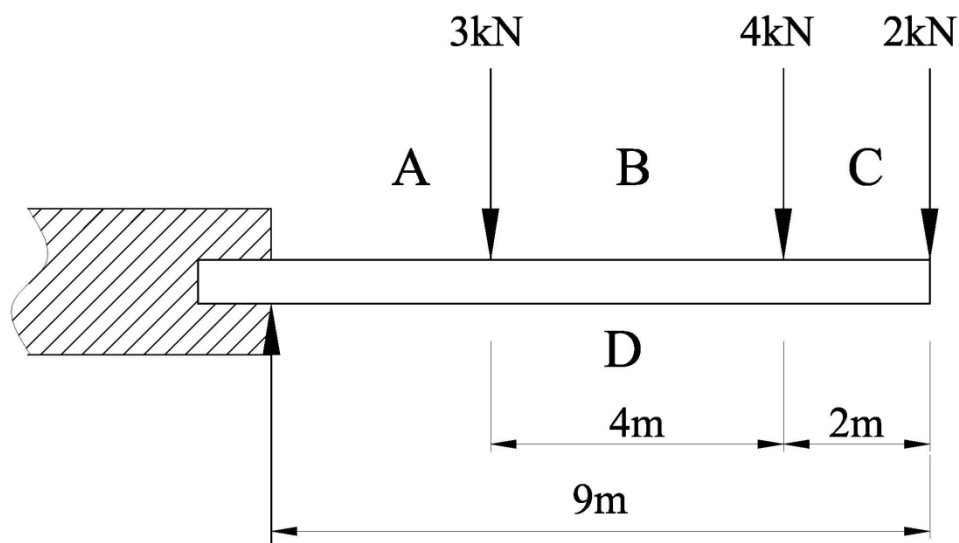
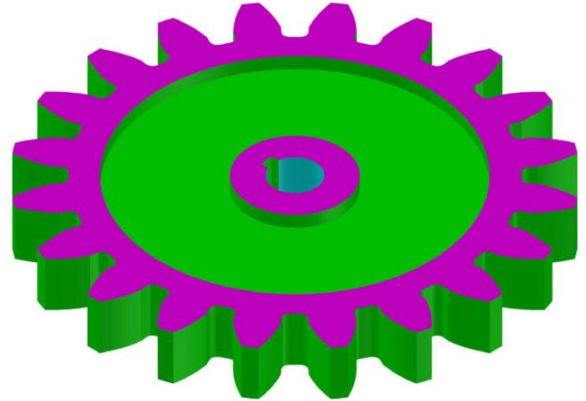

Figure 4a

(Total: 13 marks)

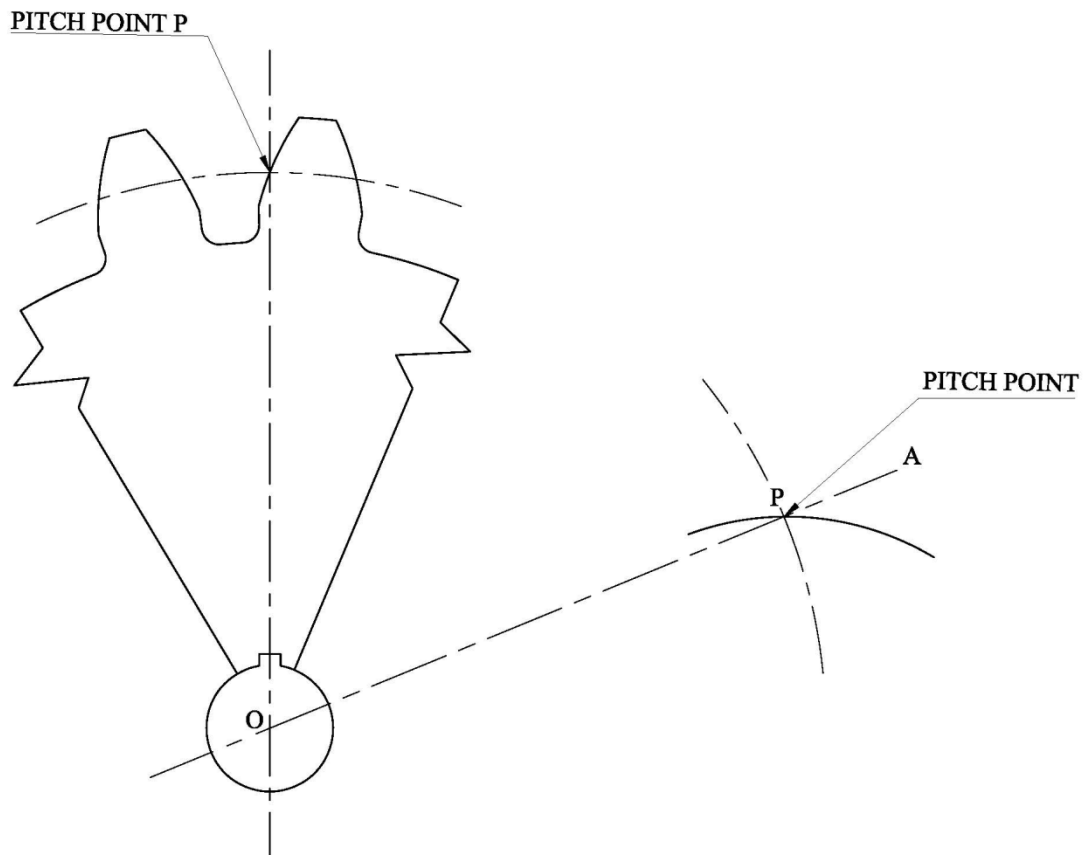
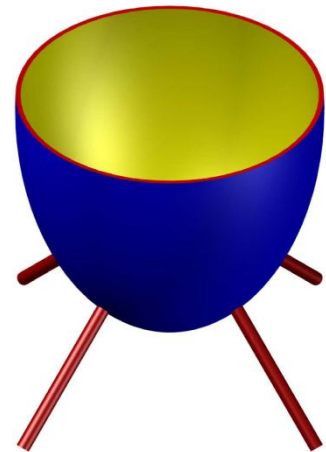

Figure 4b

Question 5

The circular container illustrated in Figure 5a is supported on a base. The vertical cross section of the container is part of an ellipse and the base consists of four legs.



- a) Copy, full size, the directrix and the vertical axis shown in Figure 5b and construct the elevation of the ellipse using an eccentricity of 4:5. The focus of the conic is 63 mm from the directrix. Plot the curve within the lines marked DR and AB. (8)
- b) Draw a normal representing one leg through the point marked N on the curve and extend to the line DR. Determine the centre of curvature for this point. (5)

(Total: 13 marks)

Figure 5a

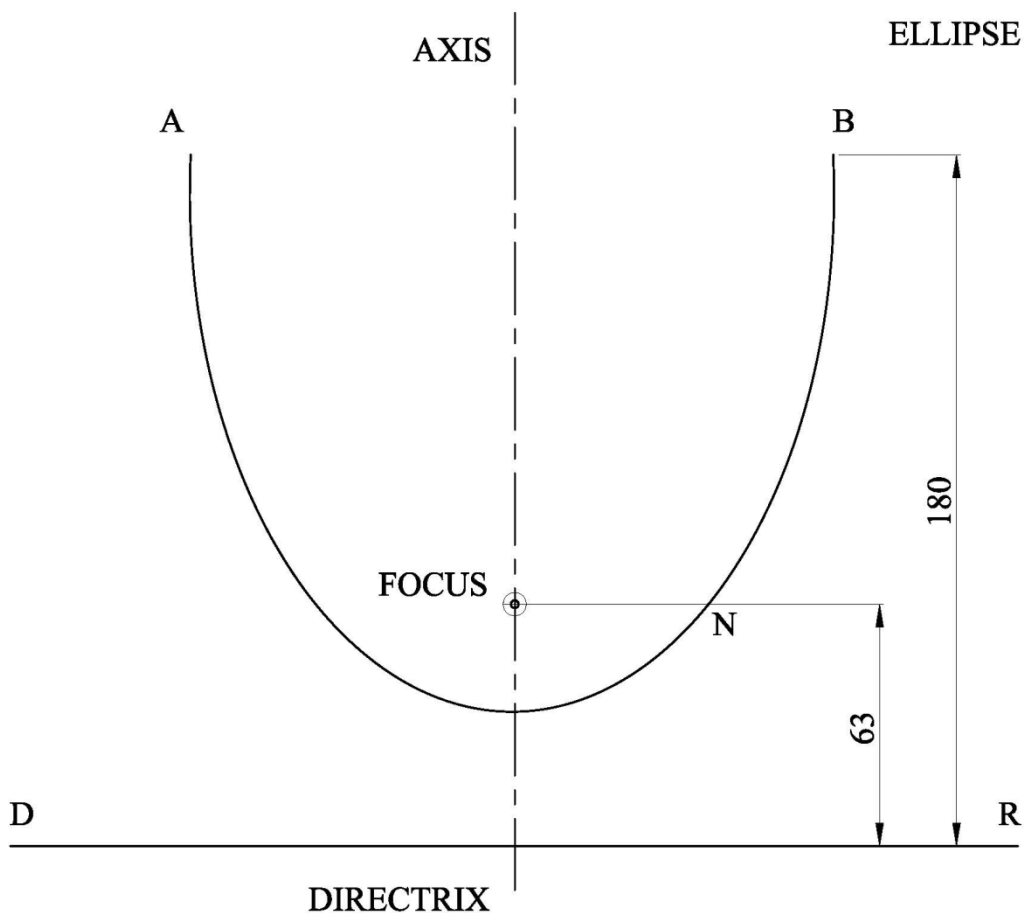

Figure 5b

SECTION B

Attempt only **ONE** question from this section.

Question 6

A diagram and details of a pulley assembly are shown in Figure 6a below and Figure 6b on the attached A3 sheet, and are assembled as follows:

- the 40 mm diameter end of the support (Item 2) fits in the 40 mm diameter bore of the base (Item 1). The face marked A on Item 2 is to be drawn parallel to the 160 mm side of the base (Item 1).
- the M16 round headed bolt (Item 3) is a free fit in the 16 mm diameter holes of the lugs on the base.
- the support is locked in position by means of the M16 bolt, washer and nut (not shown).
- the bush (Item 4) is inserted in the 40 mm diameter hole of the pulley (Item 6).
- the spindle (Item 7) fits in the 30 mm diameter hole of the bush.
- the 64 mm diameter face of the pulley, Face B, is to rest against the head of the round headed spindle (Item 7).
- the sub-assembly of the pulley, bush and spindle is fitted in the 24 mm diameter hole of the support and is locked by means of an M24 washer and nut (not shown).

Draw, full size, a sectional elevation along the horizontal centre line X - X of the complete assembly.

The face marked A on Item 2 is to be drawn parallel to the 160 mm side of the base (Item 1)

The support (Item 2) is **not** to be shown in section.

Do not show hidden detail.

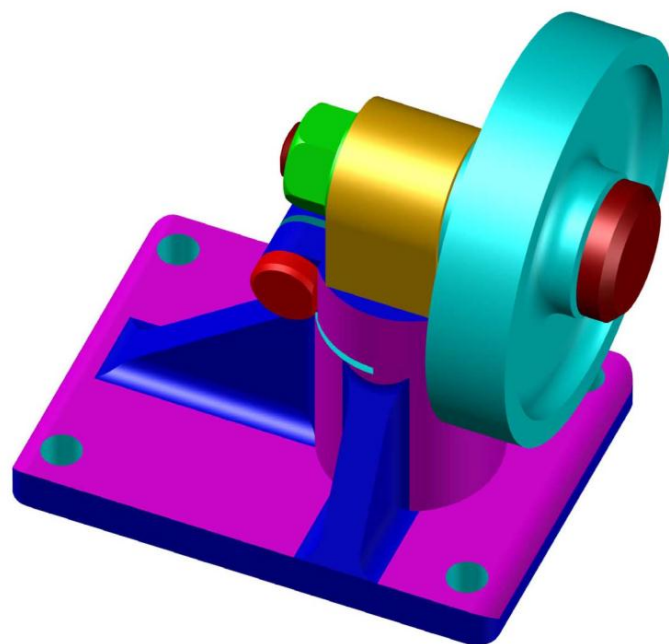

(Total: 24 marks)

Figure 6a

Question 7

A part of a clamping device is illustrated in Figure 7a. The cam lever is pivoted about the centre of the pin. The moveable jaw is spring loaded to keep the jaw always in contact with the cam profile. The cam lever moves the jaw outwards or inwards when the cam lever is turned 90°.

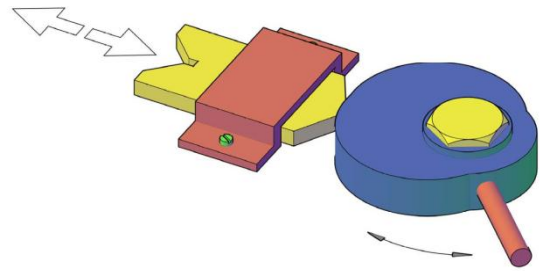

Figure 7a

a) Construct the cam profile to the following particulars:

- from 0° to 60° – rest;
 - from 60° to 150° – jaw moves outwards 36 mm with uniform velocity;
 - from 150° to 210° – jaw remains static;
 - from 210° to 300° – jaw moves inwards 36 mm with uniform velocity;
 - from 300° to 360° – jaw remains static.
- (6)

b) Draw an isometric view of the cam profile, using the details shown in Figure 7b. Place the point marked S as the lowest position of the cam.

(12)

c) Include an isometric view of the pin above the 30 mm hole of the cam lever.

(6)

(Total: 24 marks)

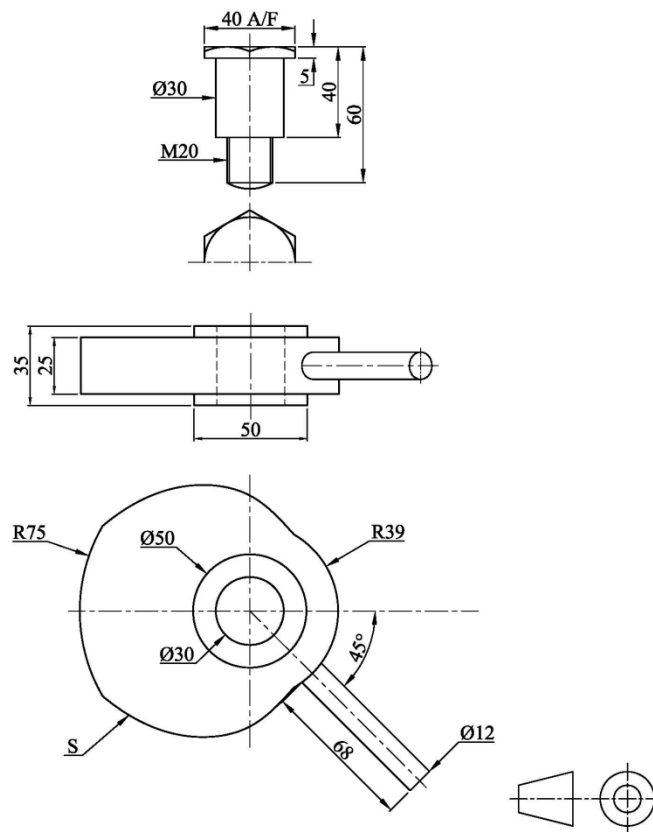

Figure 7b

SECTION C

Attempt only **ONE** question from this section.

Question 8

Table 8a shows the number of University of Malta graduates by field of study for years 2009/2010, 2010/2011 and 2011/2012 (*NSO, 2014*). Note that all figures have been rounded to the nearest multiple of five.

Table 8a. Table of graduates per year in the respective field of study.

Fields of study	University of Malta graduates		
	2009/2010	2010/2011	2011/2012
Humanities and Arts	475	510	420
Social and behavioural science	260	230	345
Law	340	330	360
Computing	170	140	80
Total	1245	1210	1205

Design a poster to show the results of the statistics:

- a) label the poster with the heading “University of Malta”; (2)
- b) draw a pictorial bar chart showing the number of graduates for years 2009/2010, 2010/2011 and 2011/2012, for all the given fields of study. Label this bar chart “Fields of study”; (11)
- c) draw a planometric pie chart showing the total number of graduates for years 2009/2010, 2010/2011 and 2011/2012. Label this pie chart “University of Malta graduates”; (11)

Poster design Tips:

- i. use colour and shading to render the drawing;
- ii. make use of typography (fonts);
- iii. form an attractive presentation, clearly conveying the information.

(Total: 24 marks)

Question 9

A film production house filming an old western film wants to construct a wooden saloon. The front view, end view and the plan are shown in Figure 9c. A pictorial view of the saloon is shown in Figure 9a. The saloon features a wooden foundation, a small room with a swinging door and a window, eight pillars supporting the roof and the sign.

Using the scale given below, construct an estimated two-point perspective view of the wooden saloon. Use the suggested layout of the perspective shown in Figure 9b.

Notes: Render your drawing to enhance the solution.

(Total: 24 marks)

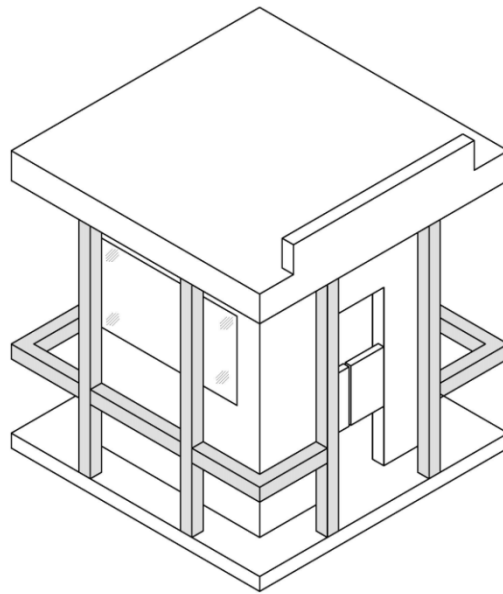

Figure 9a

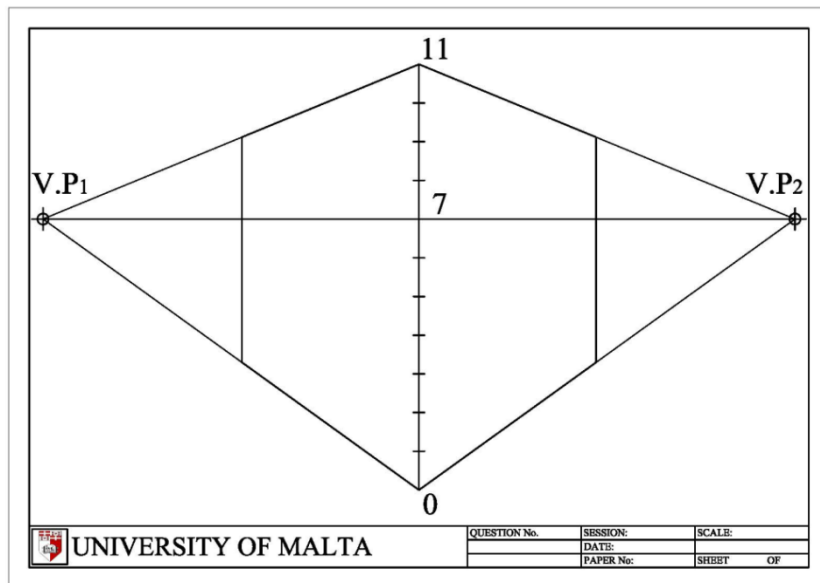

Figure 9b

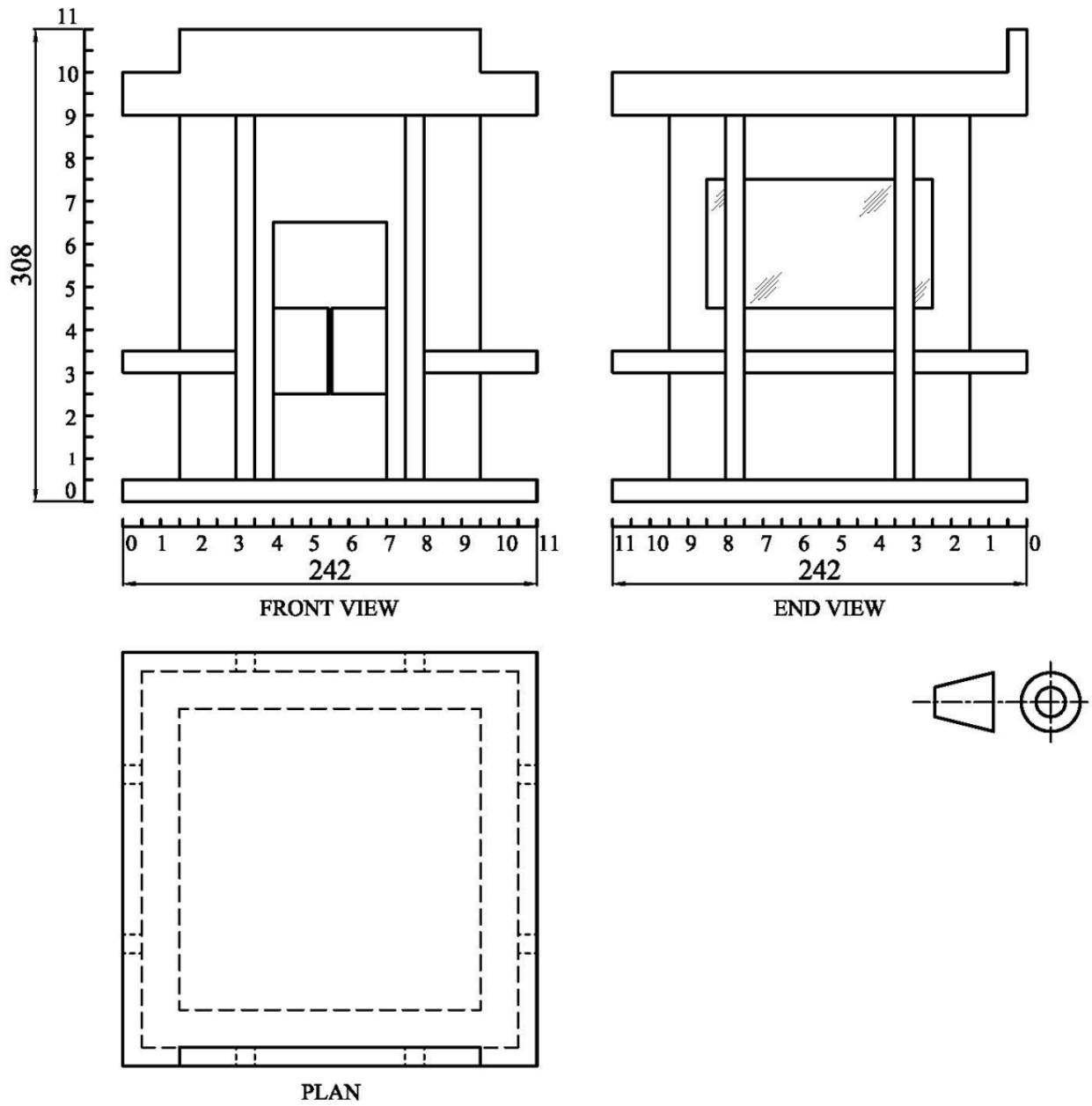
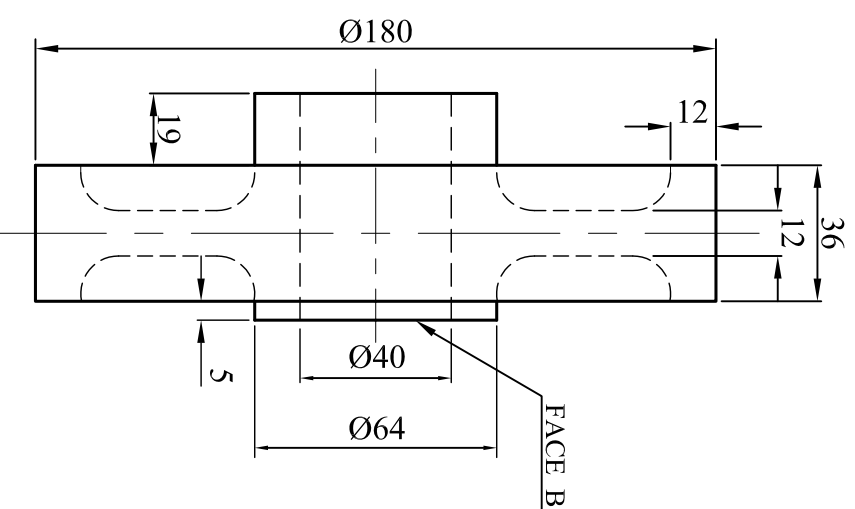
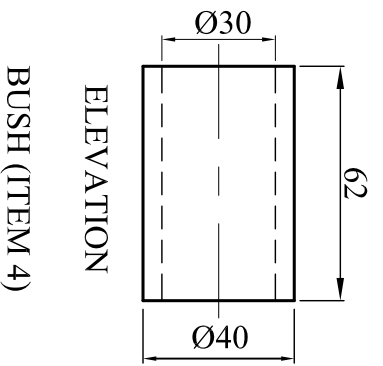
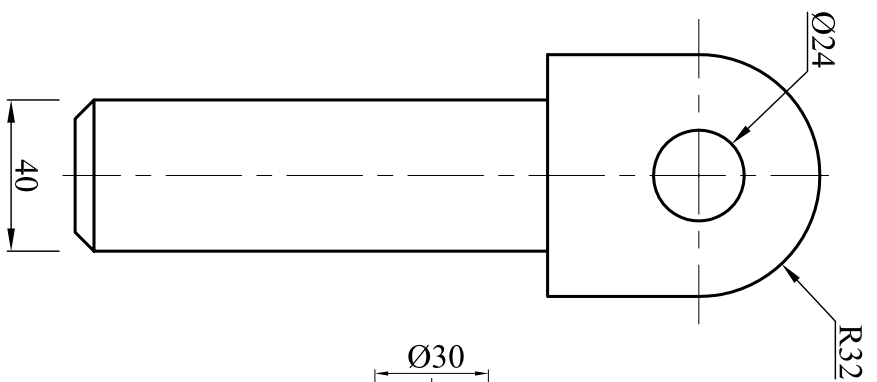
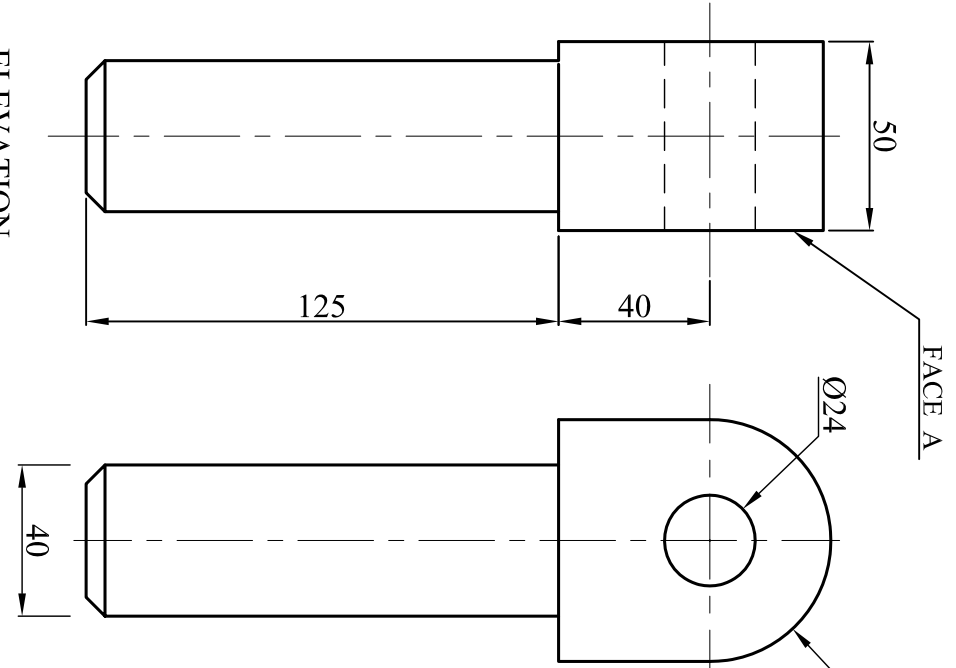
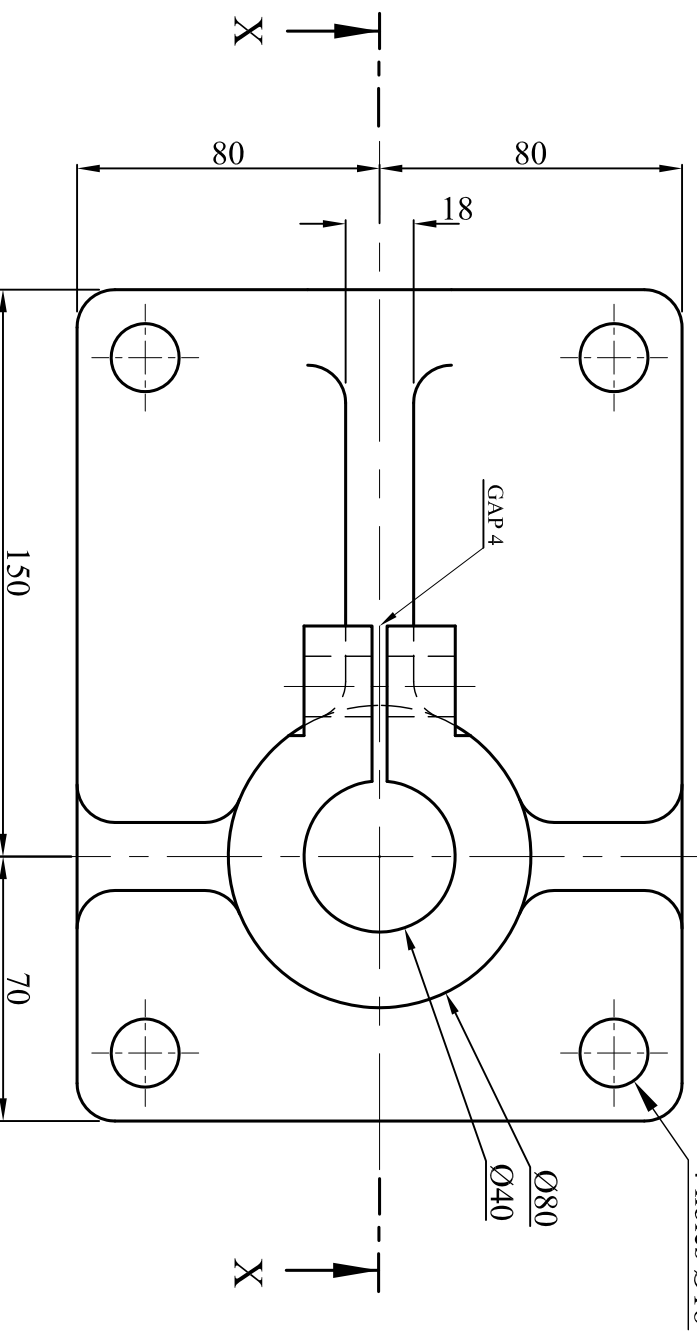
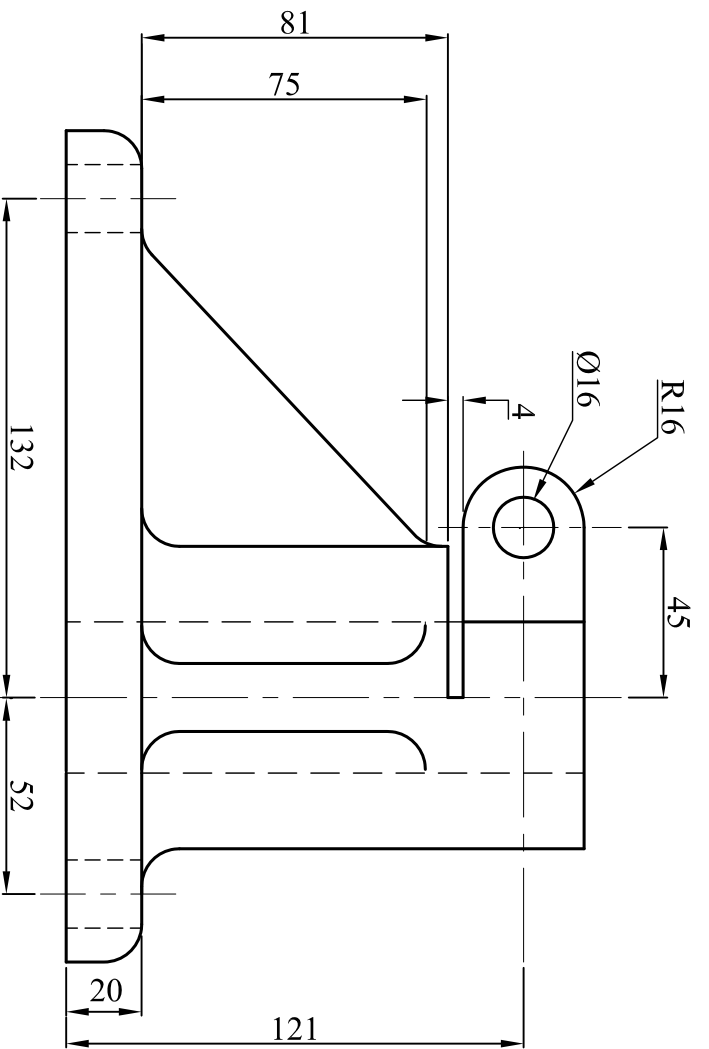

Figure 9c



BASE (ITEM 1)

SUPPORT (ITEM 2)

PULLEY (ITEM 6)

BOLT M16 (ITEM 3)

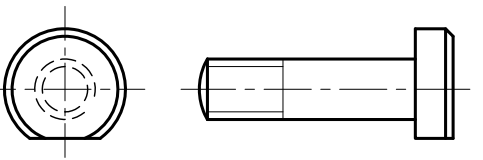

ELEVATION

SPINDLE (ITEM 7)

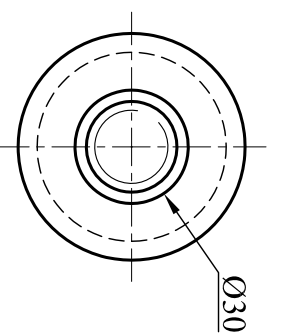
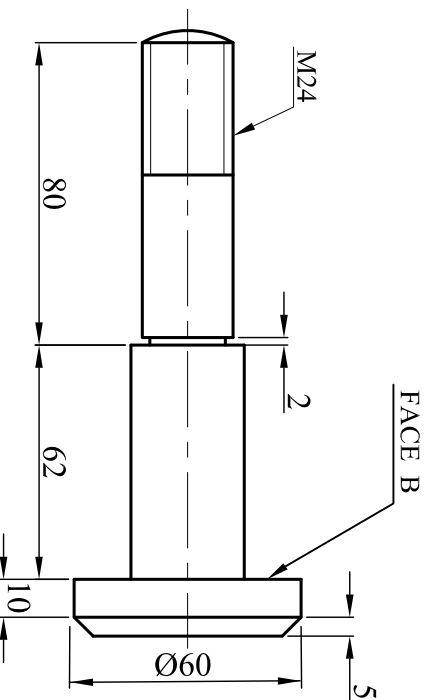

FILLET RADIUS 5

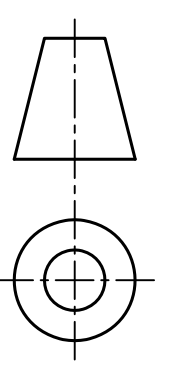

PULLEY ASSEMBLY