



---

SUBJECT:	<b>Engineering Drawing and Graphical Communication</b>
DATE:	5 <sup>th</sup> September 2019
TIME:	4:00 p.m. to 7:05 p.m.

---

**Directions to Candidates**

Write your index number where indicated at the top of all drawing sheets.

Only scientific calculators may be used. Programmable calculators are not allowed.

Unless otherwise stated:

- B.S. or equivalent (ISO) recommendations should be adopted throughout your answers;
- all dimensions are in millimetres, unless otherwise stated;
- all answers are to be accurately drawn with instruments;
- all construction lines must be left in each solution;
- drawing aids may be used.

Dimensions not given should be estimated.

Careful layout and presentation are important.

Marks will be awarded for accuracy, clarity and appropriateness of constructions.

Colour/shading may be used where appropriate.

Section A: Attempt any **FOUR** questions from five.

Section B: Attempt any **ONE** question from two.

Section C: Attempt any **ONE** question from two.

**SECTION A**

Attempt only **FOUR** questions from this section.

**Question 1**

The pictorial drawing of a particular part of machinery in an engineering machine workshop is shown in Figure 1a. The item is ready to be collected by a client together with a detailed illustration drawing.

The item was manufactured from a continuous strip of mild steel and welded to the outside of a mild steel tube.

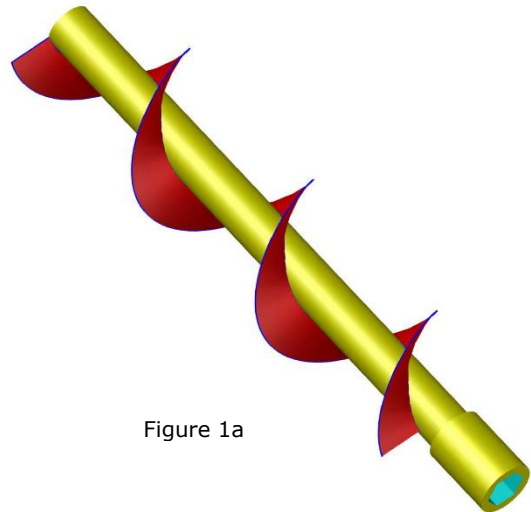

Figure 1a

- a) Construct, full size, the front elevation showing a true projection of the helical screw. Hidden detail may be omitted. (11)
- b) Next to your drawing:
  - i) Label the technical terms. (1)
  - ii) State whether the helix of the helical screw is a right hand or left hand helix. Explain your conclusion. (1)

**(Total: 13 marks)**

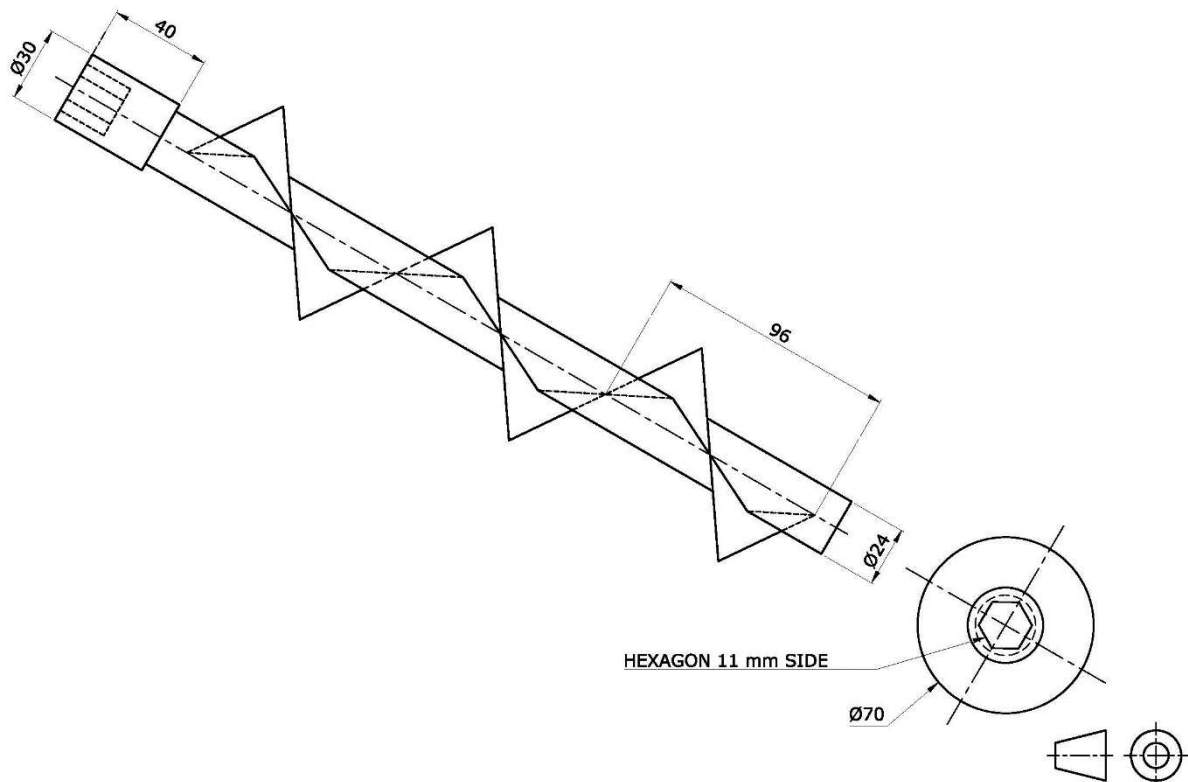

Figure 1b

**Question 2**

A section of a spur gear with 20 teeth is shown in Figure 2a. The gear teeth profiles are of involute form having a pressure angle of  $20^\circ$  and a module of 16 mm.

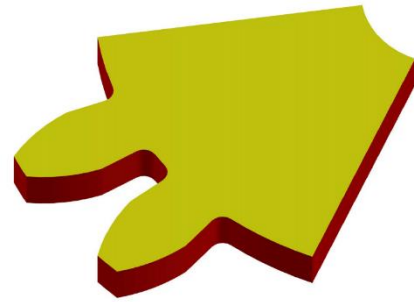

Figure 2a

- a) Write down the gear formulae and, substituting the given gear data, calculate the dimensions required to draw the spur gear teeth. Show the necessary calculations. (2)
- b) Copy, full size, the conventional representations of the gear shown in Figure 2b. Draw the pressure angle passing through the pitch point P and a semi-circle representing the base circle. (2)
- c) Construct one flank face profile of the gear, showing neatly the construction of the involute. The flank face profile of the gear is to be of true involute form. (3)
- d) Draw two teeth, one flank face passing through the pitch point Q. The flank faces of the two teeth are to be constructed using a geometrical approximate construction. (6)

**(Total: 13 marks)**

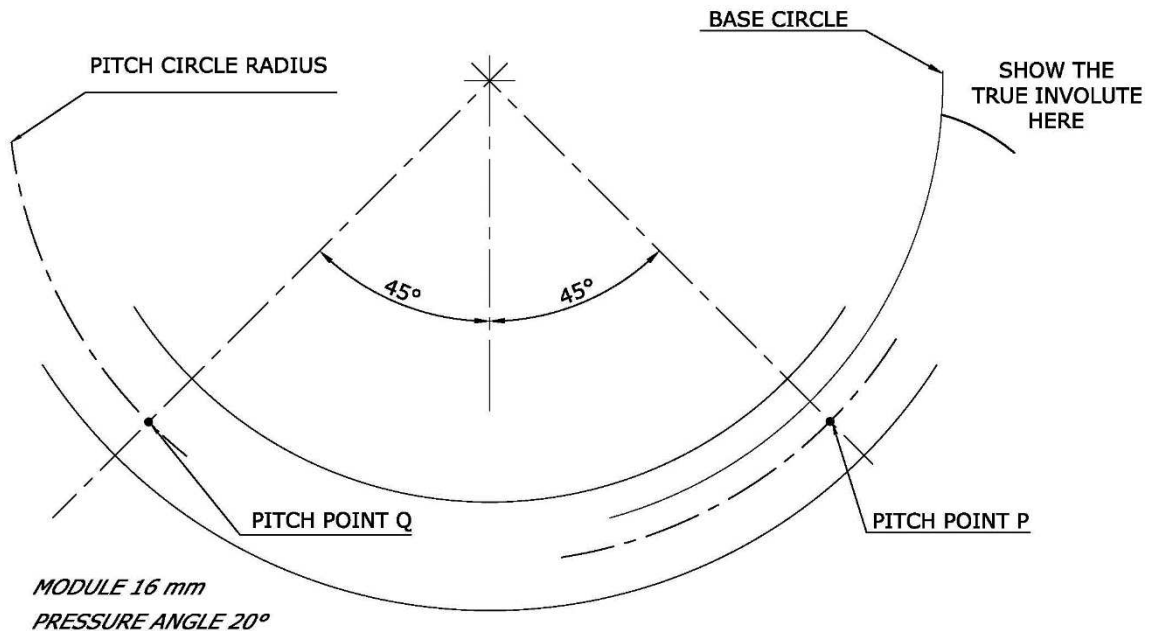

Figure 2b

**Question 3**

A beam loaded with four loads overhangs its supports at both ends is shown in Figure 3a.

- Using a scale of 10 mm representing 1 metre, copy the given space diagram shown in Figure 3b and complete with Bow's notation. (2)
- Using a scale of 10 mm representing 1 kN, draw the vector diagram to find the magnitude, direction and sense of the equilibrant. The polar distance is to be 100 mm. (2)
- Construct the funicular polygon and determine graphically the value of the left and right reaction. Write down the results. (4)
- Draw a shear force diagram. (3)
- Determine the position and distance in mm of the greatest bending moment. (2)

**(Total: 13 marks)**

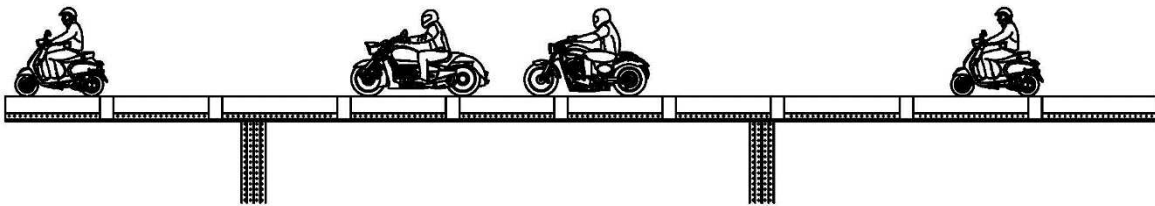

Figure 3a

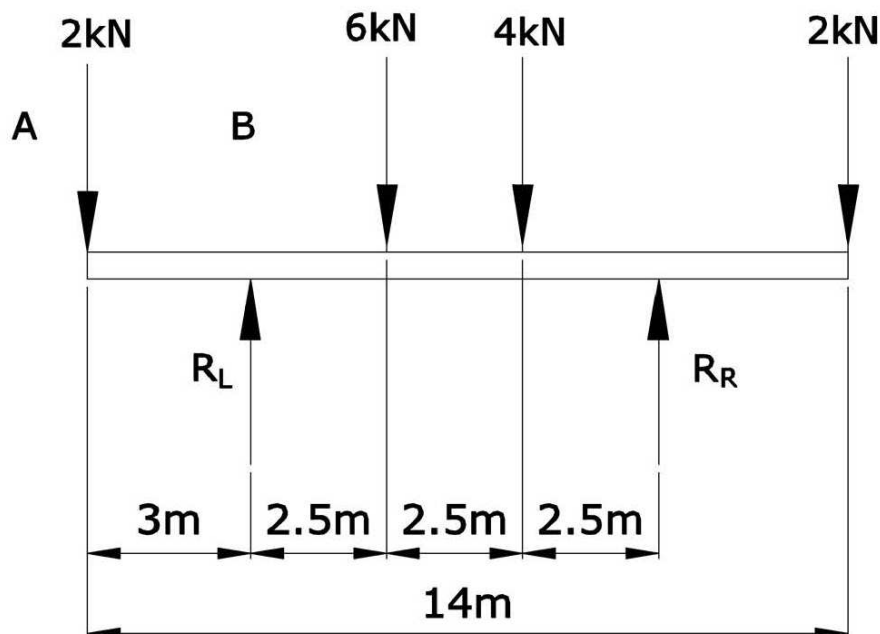

Figure 3b

**Question 4**

A close circuit camera has a body shell of basic geometrical form, a combination of a hollow right cylinder penetrating a right cone. The electronic circuit and camera are housed in the cone and the wiring and connectors, in the cylindrical portion. A mounting bracket is attached to the cylindrical portion. Refer to the illustration in Figure 4a.

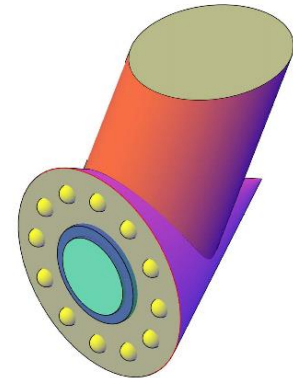

Figure 4a

- a) Copy, full size, the **THREE** given views as shown in Figure 4b. (3)
- b) Construct the curve of intersection between the two geometrical figures. (7)
- c) Present neatly the curve of intersection on the front view and the plan. Include hidden detail. (3)

**(Total: 13 marks)**

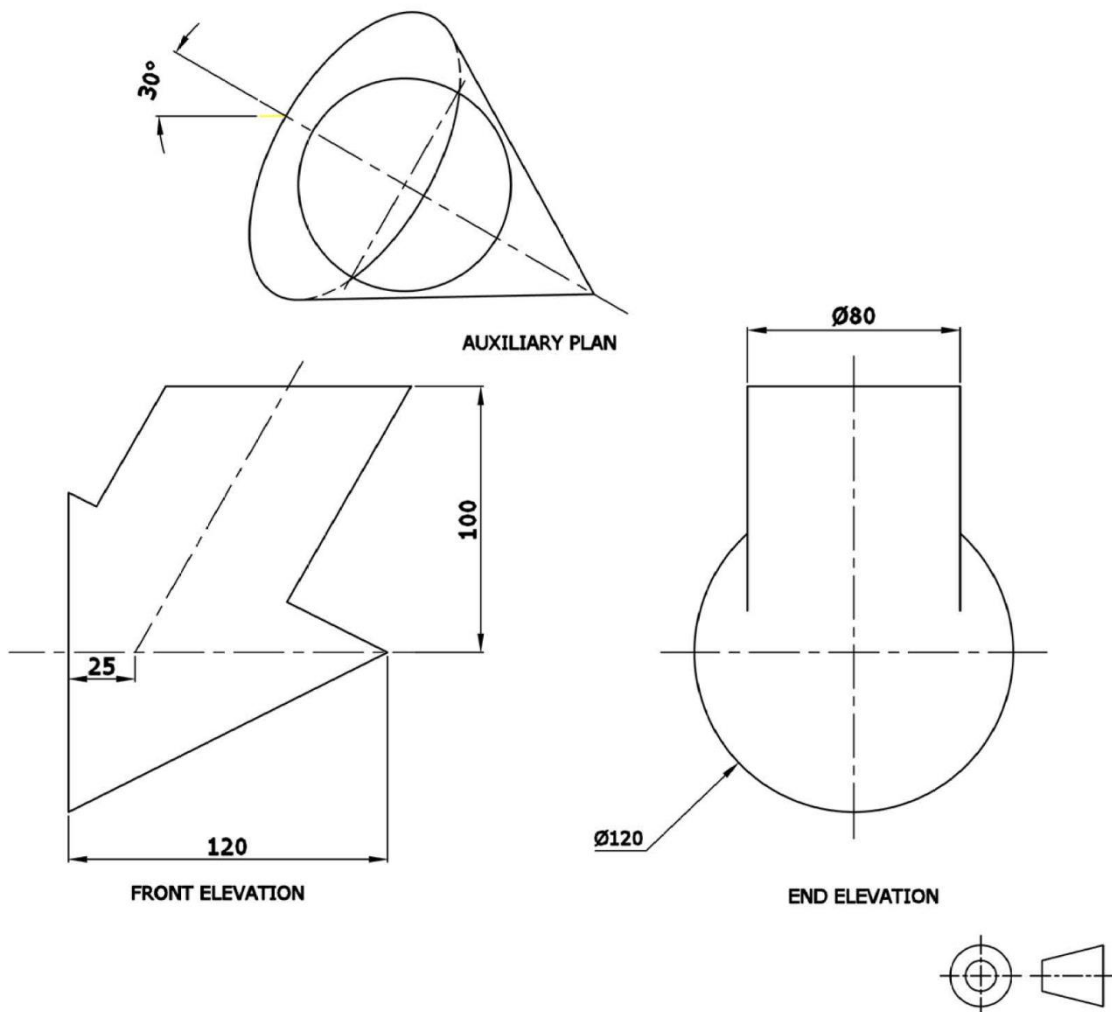

Figure 4b

**Question 5**

A sheet metal ventilation transition piece is illustrated in Figure 5a.

Construct, full size;

- a) the two views, in projection, as shown in Figure 5b; (3)
- b) the necessary true lengths required for the development of the transition piece; (4)
- c) half of the surface development of the transition piece. The joint line is to be made along the line XX. Ignore bending allowance and sheet metal thickness. (6)

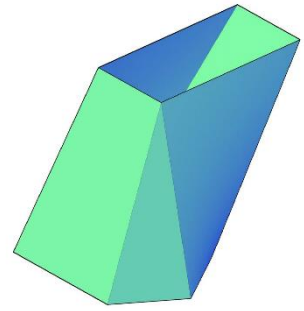
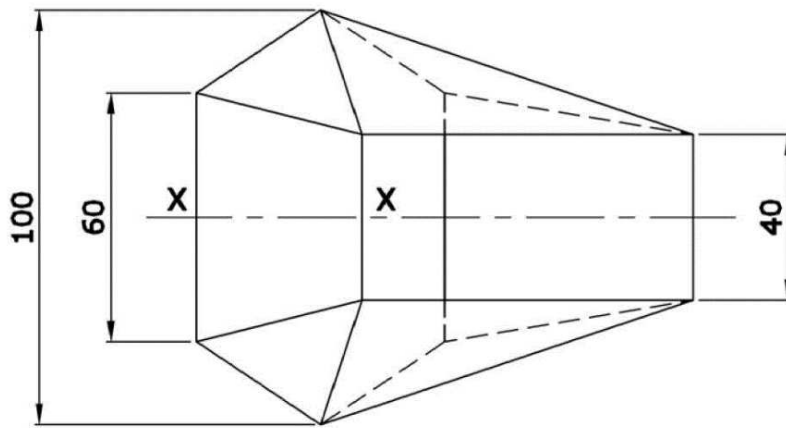
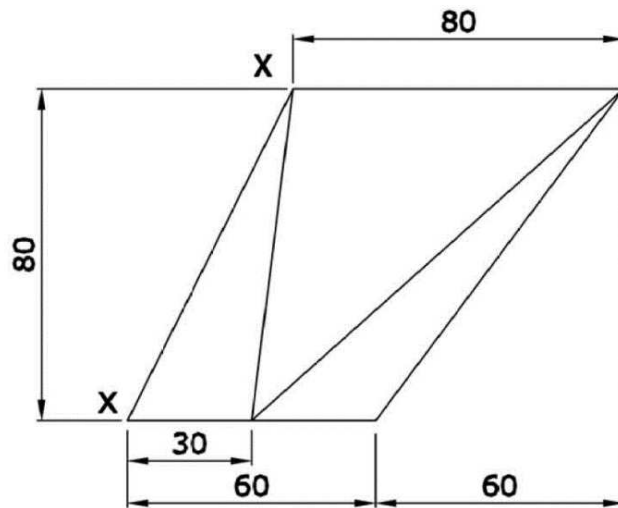

Figure 5a

**(Total: 13 marks)**



PLAN



FRONT ELEVATION

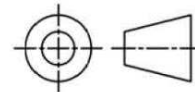

Figure 5b

**SECTION B**

Attempt only **ONE** question from this section.

**Question 6**

The pictorial drawing shown in Figure 6a, represents the components which incorporate a bilge suction strainer. Detail drawings of the bilge suction strainer parts are shown in Figure 6b on the attached A3 papers and the components are assembled as follows.

- A strainer plate 8 mm thick (Item 2) is inserted with the base A-B, into the 10 mm wide and 10 mm deep groove of the inlet compartment of the bilge box (Item 1).
- Two 4 mm diameter x 10 mm dowels (Item 3 & 4) are fitted into the 4 mm holes of the top face of the bilge box flange.
- The reinforced lid with the stiffening webs (Item 5), rests on the upper top face of the bilge flange. The reinforced lid is located by the two 4 mm diameter dowels.
- The M18 threads on the lock-pin studs (Items 6 & 7) are screwed into the two M18 mm tapped holes of the lugs at the upper flange of the box. The lock-pin studs are installed with plain waisted shanks protruding vertically from the lugs, aside of the reinforced lid.
- The 18 mm diameter X 25 mm open ended slots of the swiveling lever (Item 8) are inserted and engaged in the waisted shank 16 mm diameter X 25 mm recess of the lock-pin studs.
- An M18 hexagonal set screw (Item 9) is screwed into the M18 threaded hole of the swiveling lever with the end of the screw pressing on the top surface of the 30 mm diameter face of the reinforced lid.

In operation the fluid flows through the inlet flange into the strainer compartment. The fluid passes through the strainer plate and the fluid flows out through the cylindrical outlet port.

- a) With the bilge suction strainer fully assembled, draw full size, omitting hidden detail, a front view, including the stepped section on the cutting plane X - X. (23)

The outline of the cylindrical outlet port and flange, are not to be drawn.

- b) Add the title. (1)

**(Total: 24 marks)**

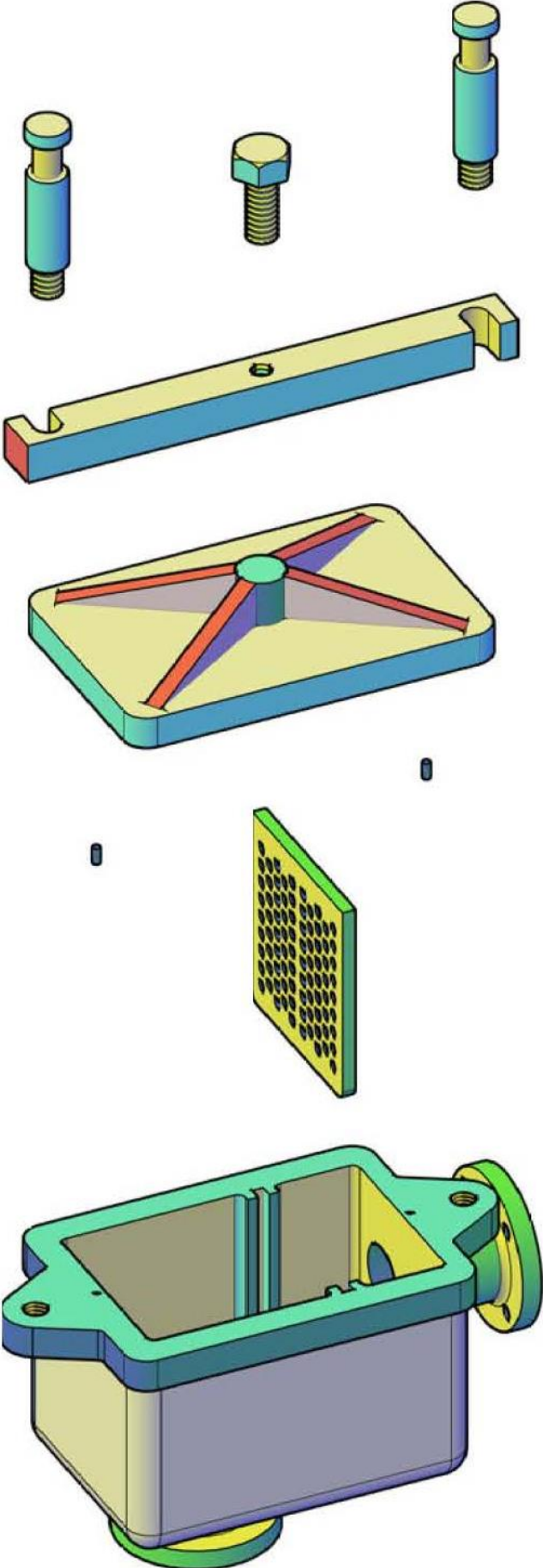

Figure 6a



**Question 7**

Orthographic views of the parts of a Gripper (Figure 7a) are given in Figure 7b overleaf.

a) Present an isometric drawing of the given parts as an illustration for assembly.

Present the main assembly items relatively aligned along the handle centre-line; with the jaws in the lower left corner of the drawing, projected to the upper right corner of the drawing.

- i) For clarity, show the jaws and the side plate aligned but displaced from their assembled position, as an exploded illustration detail. Show only one side plate. Avoid overlap which compromises detail.
- ii) Draw the square head bolt assembled to the handle. Show part of the M14 threaded portion exposed. (Extended approx. 30 mm).
- iii) Do not include the 5 mm diameter spring pins on the drawing. Represent their presence in the assembly by centre lines.

Note: Complete orthographic views are not required, draw ONLY essential parts of the orthographic view detail which are necessary for the construction work for the completion of isometric detail. (22)

b) Print the title; 'ISOMETRIC VIEW OF GRIPPER', centred below the isometric assembly. (2)

**(Total: 24 marks)**

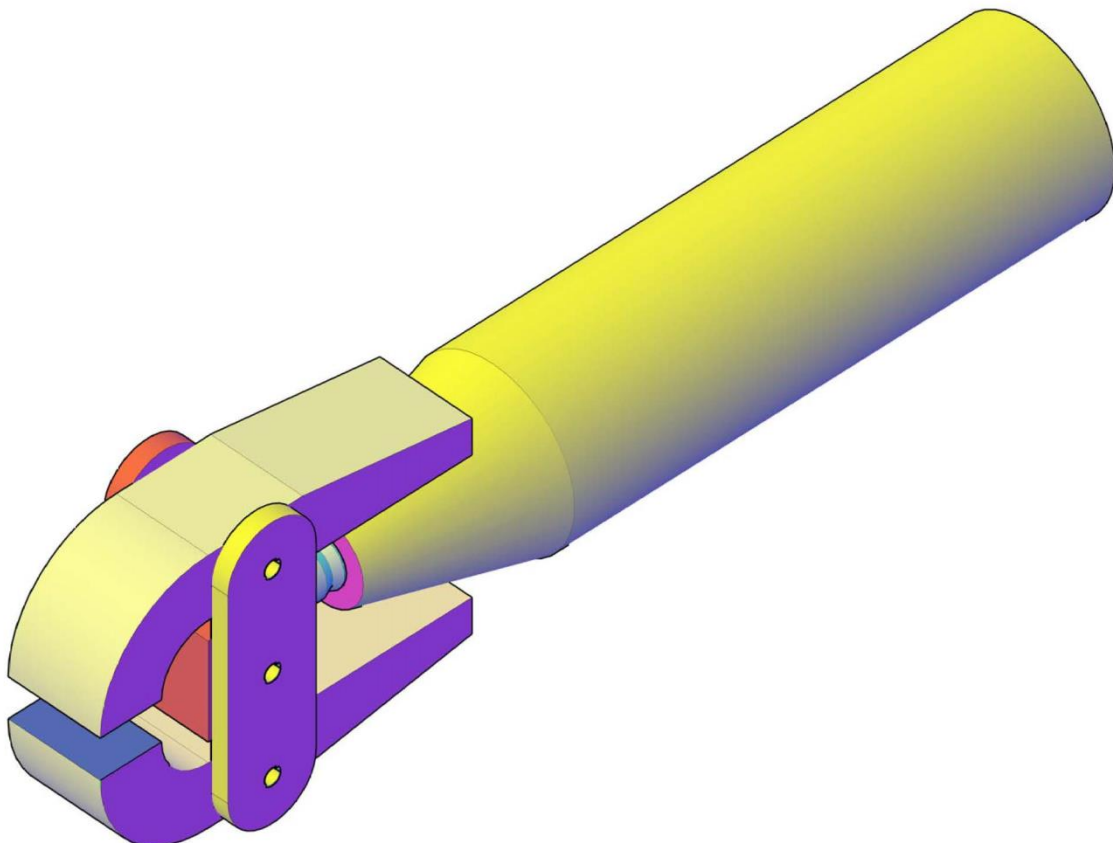
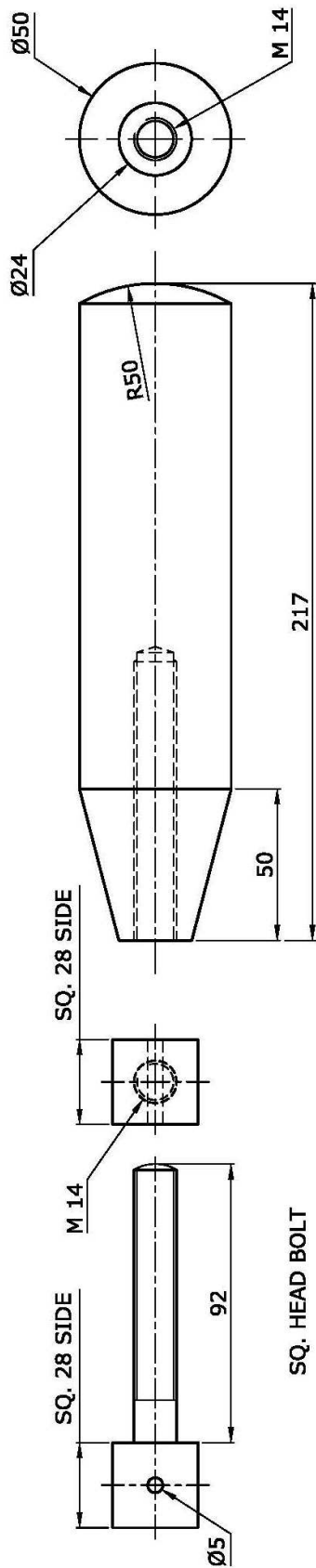
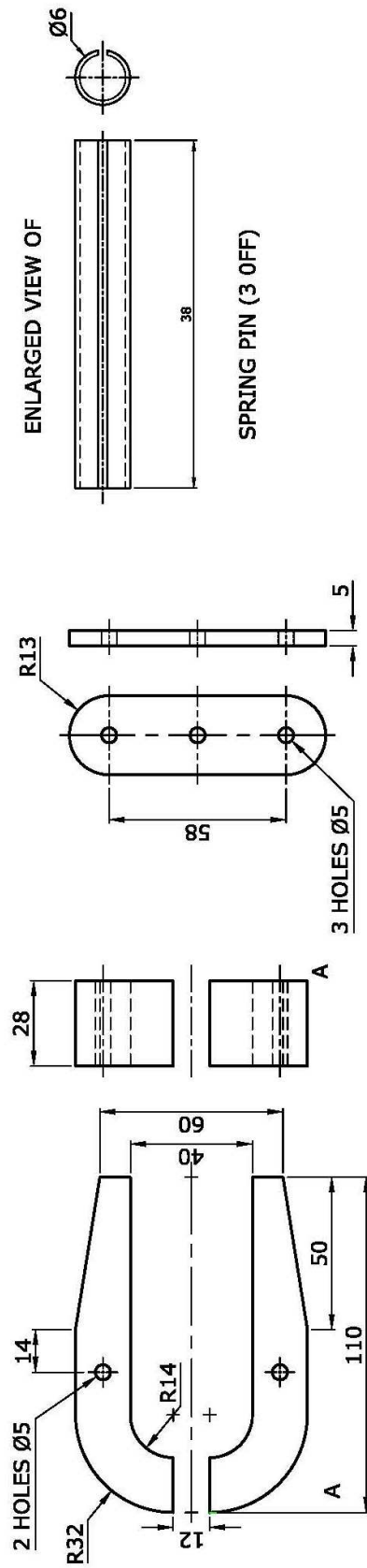

Figure 7a



SQ. HEAD BOLT

HANDLE



JAWS

SIDE PLATE (2 OFF)

ENLARGED VIEW OF

SPRING PIN (3 OFF)

GRIPPER

Figure 7b

**SECTION C**

Attempt only **ONE** question from this section.

**Question 8**

Table 8a shows the number of cruise liner passengers coming from a number of EU Member states for 2017, 2018 and 2019 from January to March while Table 8b shows the number of cruise liner passengers coming from a number of Non EU Member states for 2017, 2018 and 2019 from January to March (*published by NSO, 2019*). Note that all figures have been rounded up.

Table 8a: Number of cruise liner passengers coming from EU Member states for 2017, 2018 and 2019 from January to March

EU Member state	Cruise liner passenger traffic from a number of EU Member states (January-March per year)		
	2017	2018	2019
Germany	8400	8800	6700
Spain	3000	5000	5400
Great Britain	6700	2500	5600

Table 8b: Number of cruise liner passengers coming from Non EU Member states for 2017, 2018 and 2019 from January to March

Non EU Member state	Cruise liner passenger traffic from a number of Non EU Member states (January-March per year)		
	2017	2018	2019
Australia	1400	700	1600
Canada	1400	1000	1700
Japan	2500	3400	2500
<b>Total</b>	<b>5300</b>	<b>5100</b>	<b>5800</b>

Design a poster which displays the statistics shown.

- a) Label the poster with the heading "Cruise Liner Passengers". (3)
- b) Draw a line graph showing the number of passengers coming from Germany, Spain and Great Britain for years 2017, 2018 and 2019. Label this line graph "Cruise liner passengers from EU member states". (7)
- c) Draw a bar chart showing the number of passengers coming from Australia, Canada and Japan for years 2017, 2018 and 2019. Label this bar chart "Cruise liner passengers from Non EU member states". (7)
- d) Draw a planometric pie chart showing the total number of Non EU passengers for years 2017, 2018 and 2019. Label this pie chart "Total number of cruise liner passengers from Non EU members". (7)

Poster design tips:

- i) use colour and shading to render the drawing;
- ii) make use of typography (fonts);
- iii) form an attractive presentation, clearly conveying the information.

**(Total: 24 marks)**

**Question 9**

A furniture company bought an old showroom and intends to renovate it into a modern one.

The front view, end view and the plan are shown in Figure 9a. A pictorial view of the showroom is shown in Figure 9b. The showroom is at a corner, having an offset wall, two side doors, one main door which serves as a main entrance, and six large windows.

a) To a scale of 1:25, construct an estimated two-point perspective view of the showroom. Use the suggested layout of the perspective shown in Figure 9c. (21)

b) Render in colour your drawing to enhance its presentation. (3)

**(Total: 24 marks)**

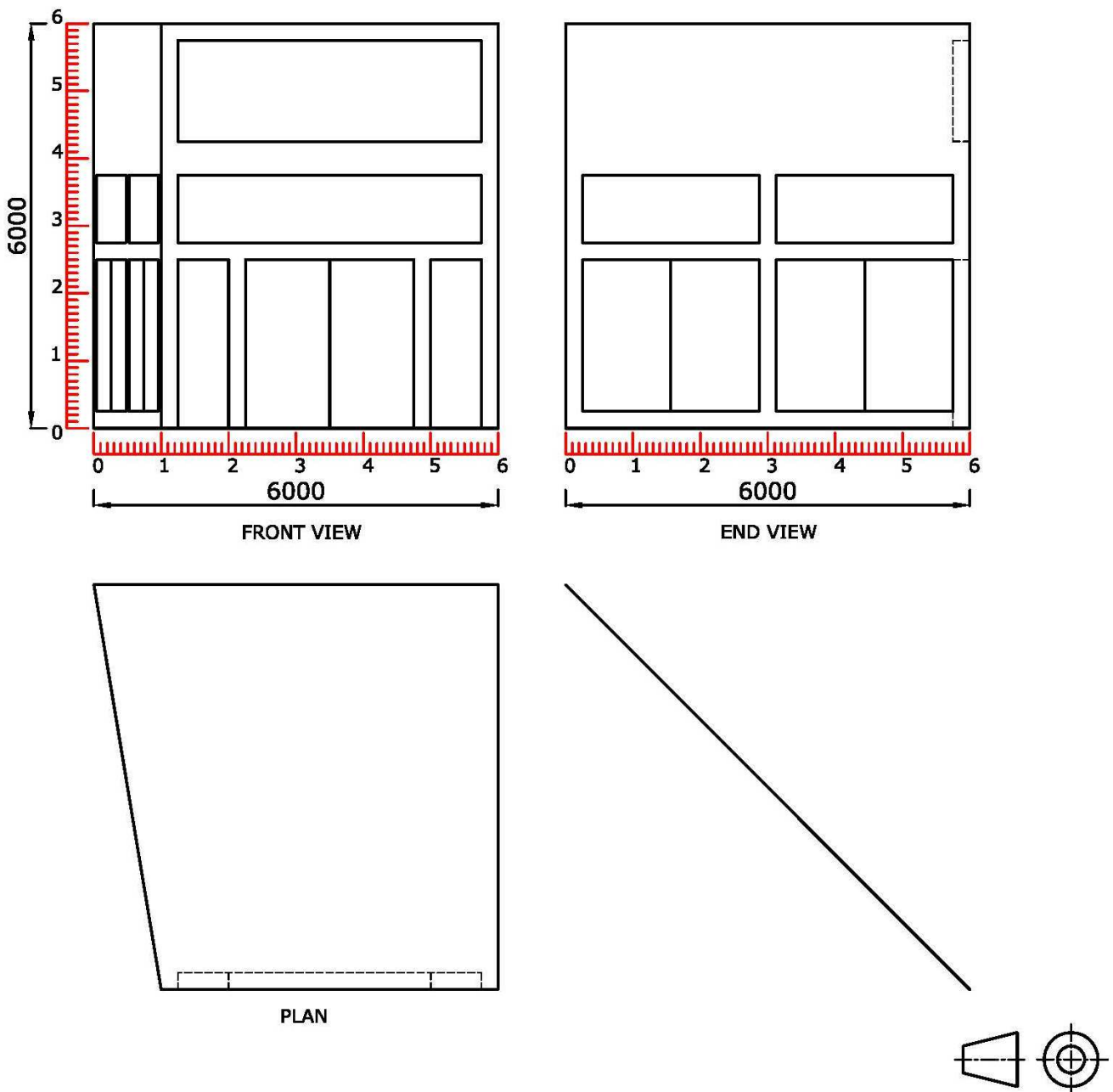

Figure 9a

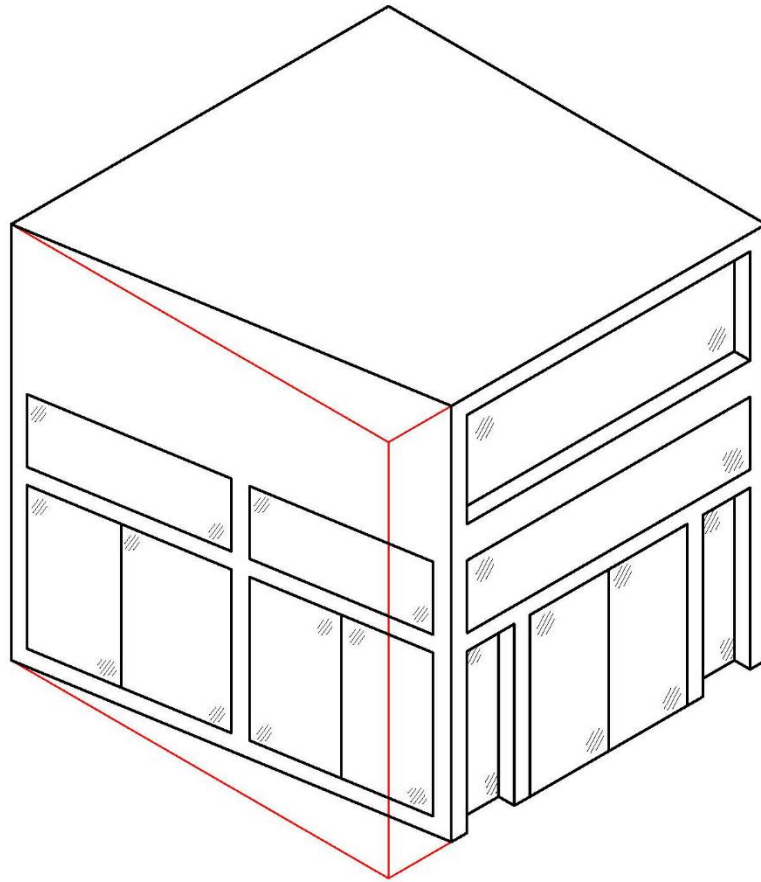

Figure 9b

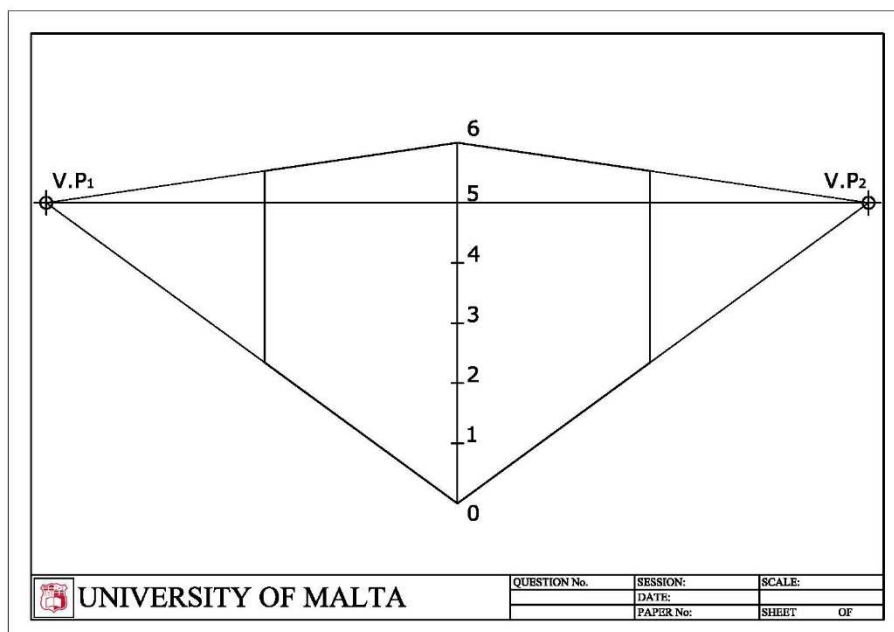
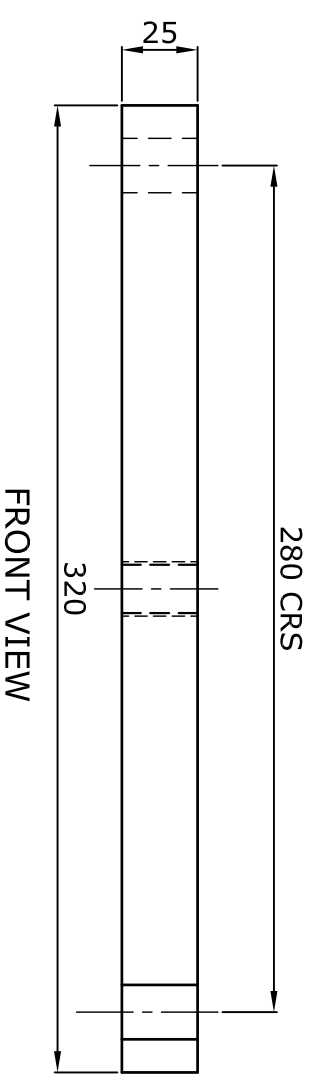
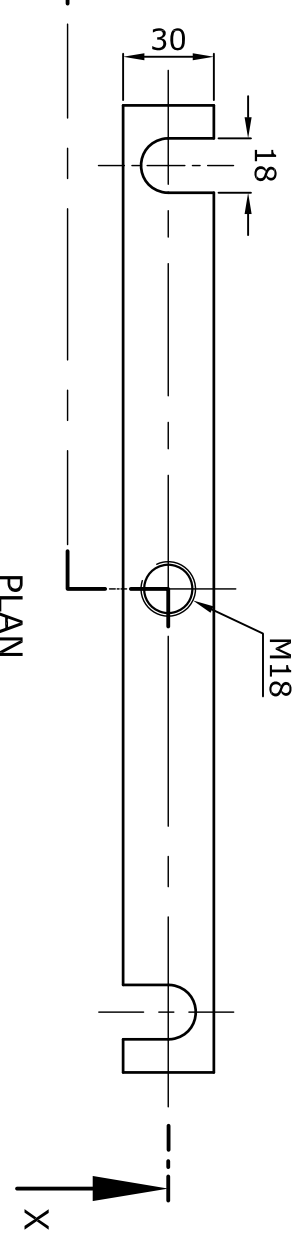

Figure 9c





FRONT VIEW



PLAN

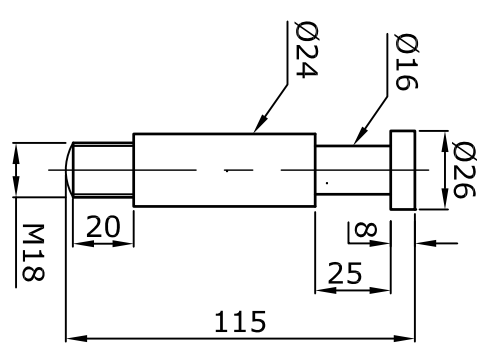

LOCK PIN STUD (ITEM 6 & 7)

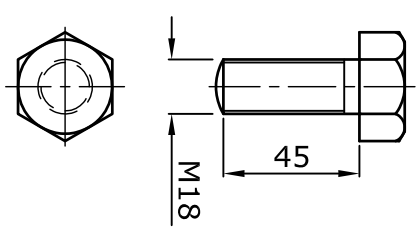

HEX SET SCREW (ITEM 9)

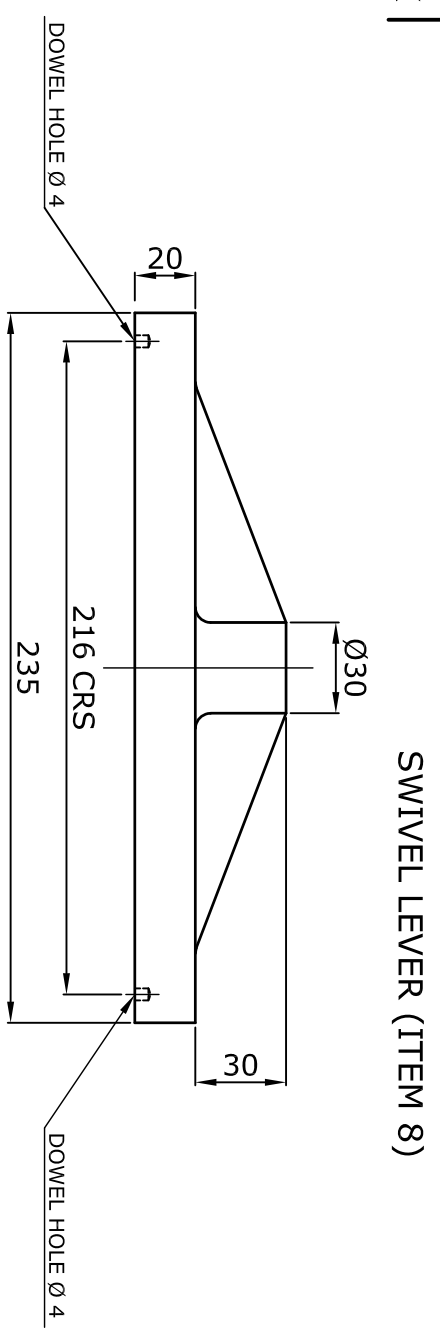

SWIVEL LEVER (ITEM 8)

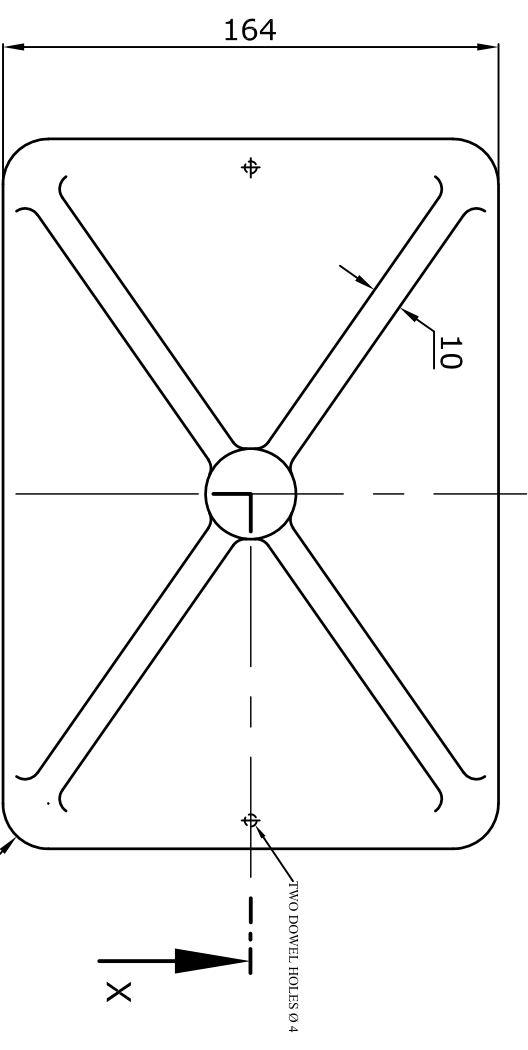

PLAN

COVER LID (ITEM 5)

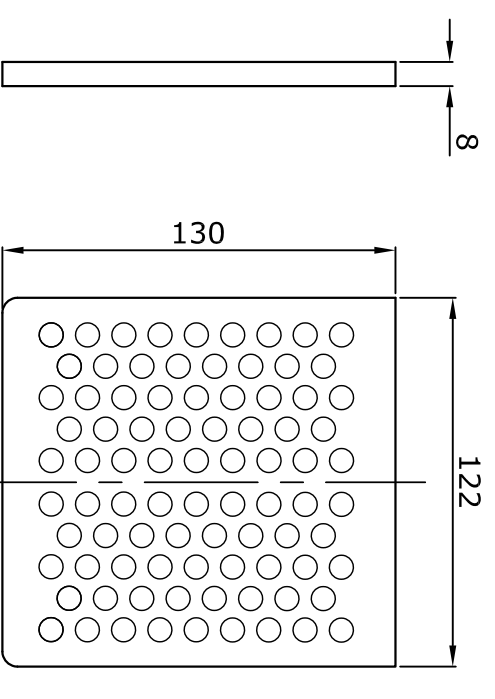

FRONT VIEW

END VIEW

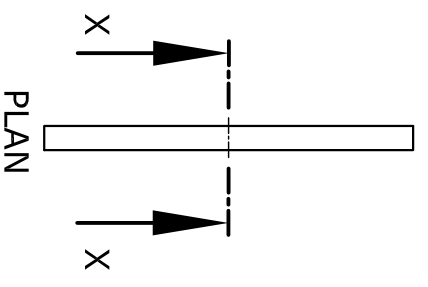

STRAINER PLATE (ITEM 2)

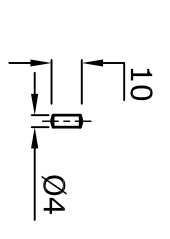

DOWEL (ITEM 3 & 4)

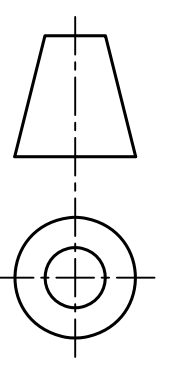

# BILGE SUCTION STRAINER