



SUBJECT:	Engineering Drawing and Graphical Communication
DATE:	12 th October 2021
TIME:	4:00 p.m. to 7:05 p.m.

Directions to Candidates

Write your index number where indicated at the top of all drawing sheets.

Only scientific calculators may be used. Programmable calculators are not allowed.

Unless otherwise stated:

- B.S. or equivalent (ISO) recommendations should be adopted throughout your answers;
- all dimensions are in millimetres;
- all answers are to be accurately drawn with instruments;
- all construction lines must be left in each solution;
- drawing aids may be used.

Dimensions not given should be estimated.

Careful layout and presentation are important.

Marks will be awarded for accuracy, clarity and appropriateness of constructions.

Colour/shading may be used where appropriate.

Section A: Attempt any **FOUR** questions from six.

Section B: Attempt any **ONE** question from three.

Section C: Attempt any **ONE** question from three.

SECTION A

Attempt any **FOUR** questions from this section.

Question 1

A transition piece connecting a hexagonal and circular duct is illustrated in Figure 1a. The top and bottom surfaces of the transition piece are parallel.

- a) Copy, full size, the elevation and plan shown in Figure 1b. (2)
- b) Form on the surface of the transition piece, the necessary triangles on the elevation and plan. Label the points by using numbers and letters. (2)
- c) Establish the true lengths of the required lines by using an appropriate construction. (3)
- d) Form half of the pattern of the transition piece by constructing the surface development using the triangulation method. Draw the joint line along the line 1 - M. (6)

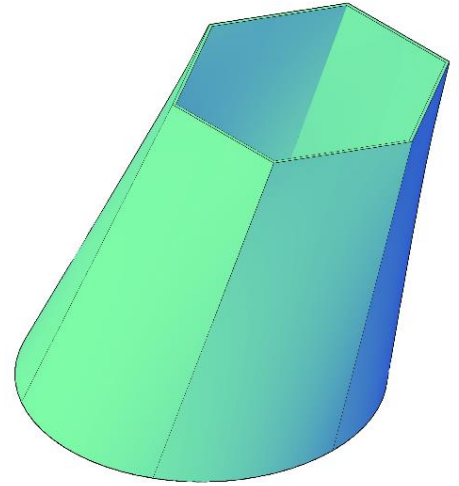

Figure 1a

(Total: 13 marks)

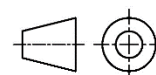
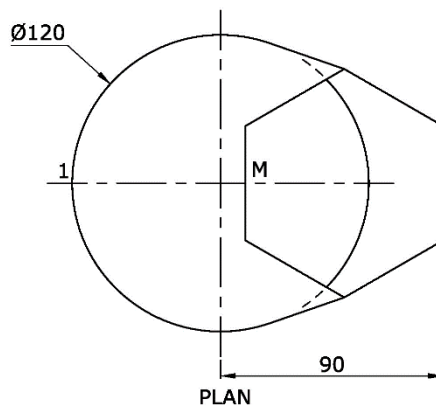
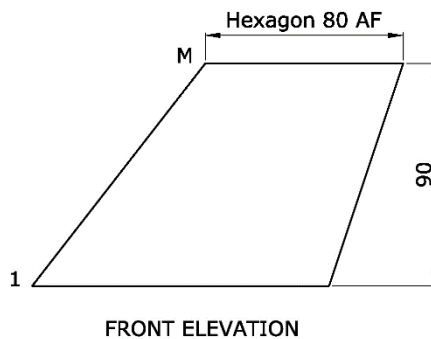

Figure 1b

Question 2

Three spheres rest on the horizontal plane, each touching the other two, as shown in Figure 2a.

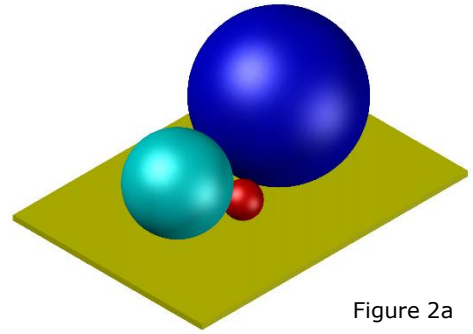

Figure 2a

- a) Copy, full size, Figure 2b, showing how the point of contact between the two spheres is geometrically found on the two views. (4)
- b) A third sphere, 30 mm diameter is placed on the horizontal plane in mutual contact with the other two spheres. Draw a complete plan and elevation of the spheres showing in **each** view **all** points of contact between them. (9)

(Total: 13 marks)

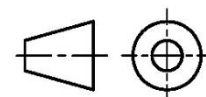
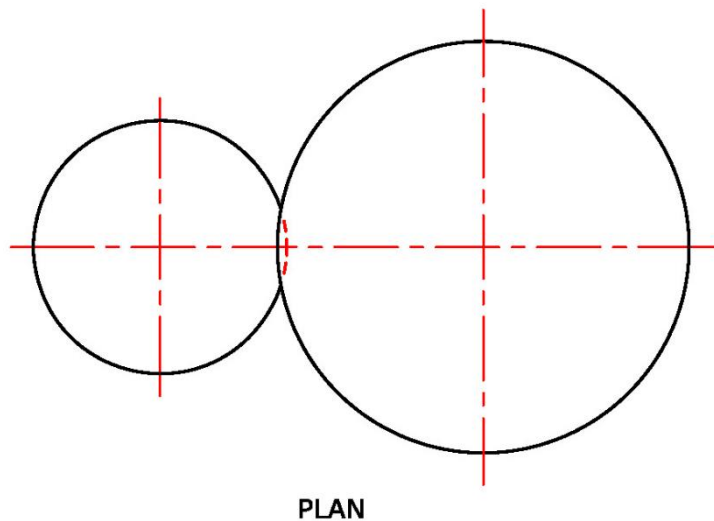
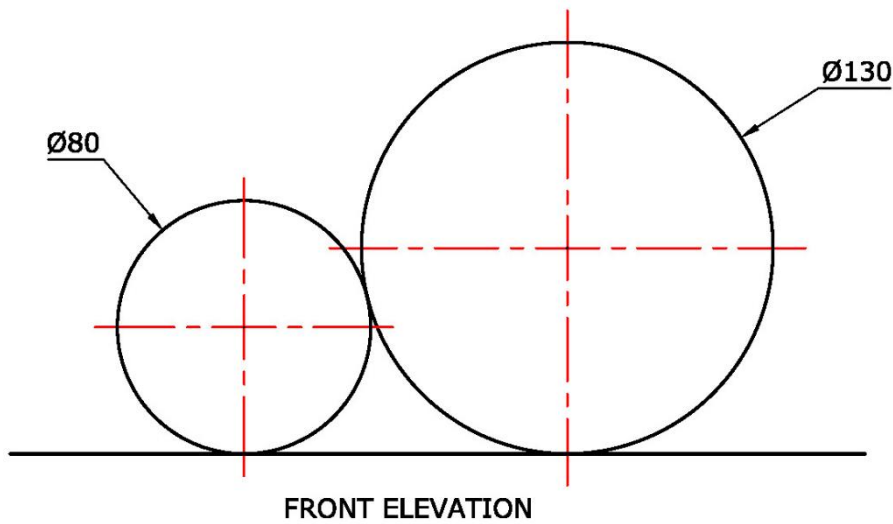

Figure 2b

Question 3

The uniform rod shown in Figure 3b is hinged to a wall at point B and supported by a wire from the wall at point A. The length of the rod is 6 m and the weight of the rod is 100 N. A pictorial representation of the rod is shown in Figure 3a.

- a) Draw the space diagram using a scale of 10 mm representing 0.5 metre. (3)
- b) Find the point of concurrency of the three concurrent forces on the diagram. (2)
- c) Construct a vector diagram using a scale of 10 mm representing 5 N and determine graphically:
 - i. the reaction at the wall at point A; (3)
 - ii. the reaction at the hinge at point B. (5)

State the magnitude, direction and angle to the horizontal plane of **each** reaction.

(Total: 13 marks)

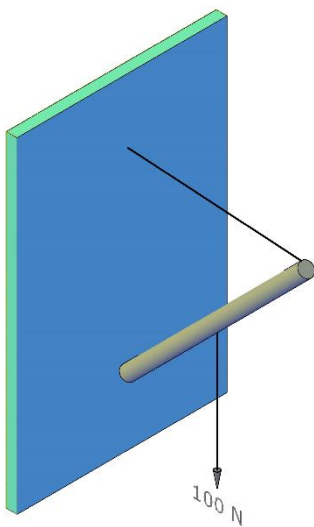

Figure 3a

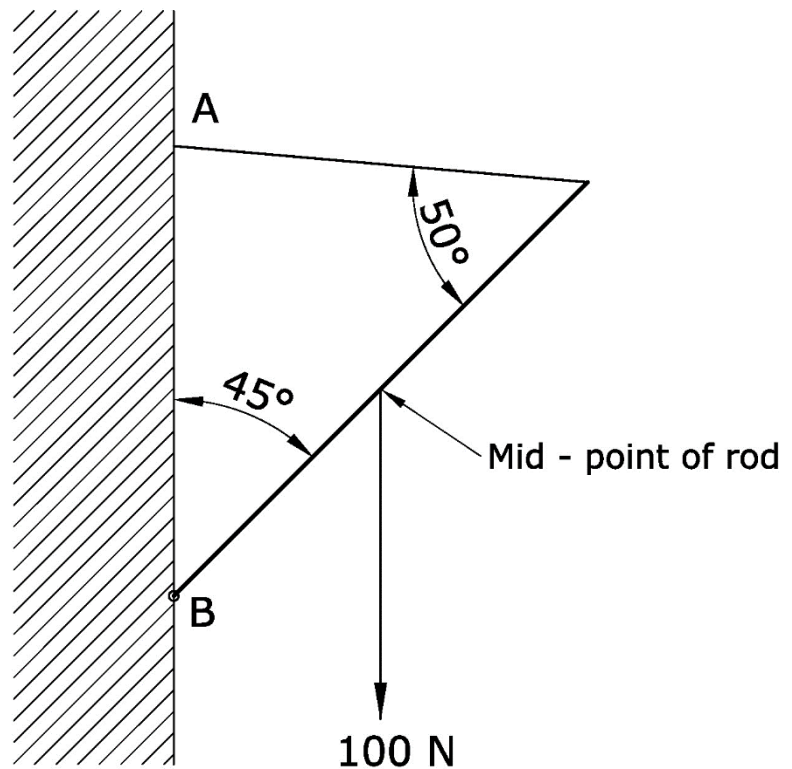

Figure 3b

Question 4

A pictorial view of a spur gear is shown in Figure 4a. The number of teeth of the spur gear is 14 and the module of the spur gear is 20. The pressure angle is 20°.

- a) Using the formulae with the given data, obtain the pitch circle diameter, the addendum, the dedendum the circular pitch and the tooth thickness. (2)
- b) Construct the true involute curve of the gear. (5)
- c) Draw **TWO** teeth of the spur gear. The flanks of **each** tooth may be drawn using an approximate construction; (5)
- d) Indicate on the drawing, the addendum, the dedendum and pitch point of the gear. (1)

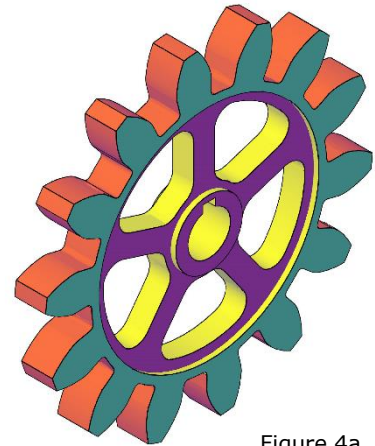

Figure 4a

Note that the solution may be presented as shown in Figure 4b.

(Total: 13 marks)

a) Pitch circle diameter:
 The addendum:
 The dedendum:
 The circular pitch:
 The tooth thickness:

c) Two teeth of the spur gear

d) Indicate

b) True Involute

UNIVERSITY OF MALTA	QUESTION No. 4	SESSION:	SCALE:
		DATE:	
		PAPER No:	SHEET OF

Question 5

A covered entrance to a door-way is illustrated in Figure 5a. This space in front of the entrance of the building, is designed to provide sufficient space for a person to shelter before entering the house.

- a) Reproduce, full size, the front elevation and plan of the porch shown in Figure 5b. (3)
- b) Project an auxiliary elevation on to the X1-Y1 line, showing the view when looking in the direction of the arrow marked S. (10)

(Total: 13 marks)

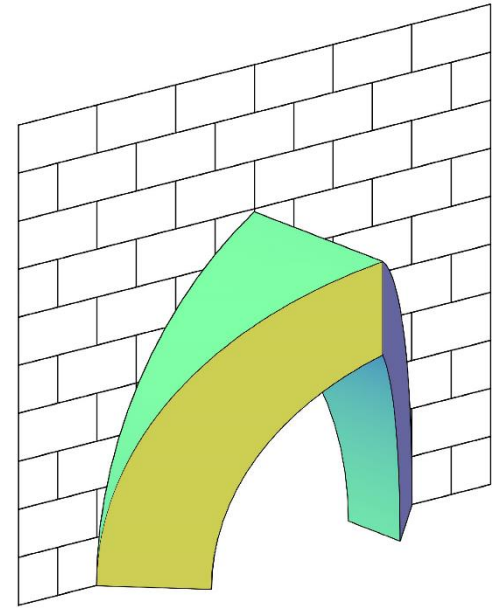

Figure 5a

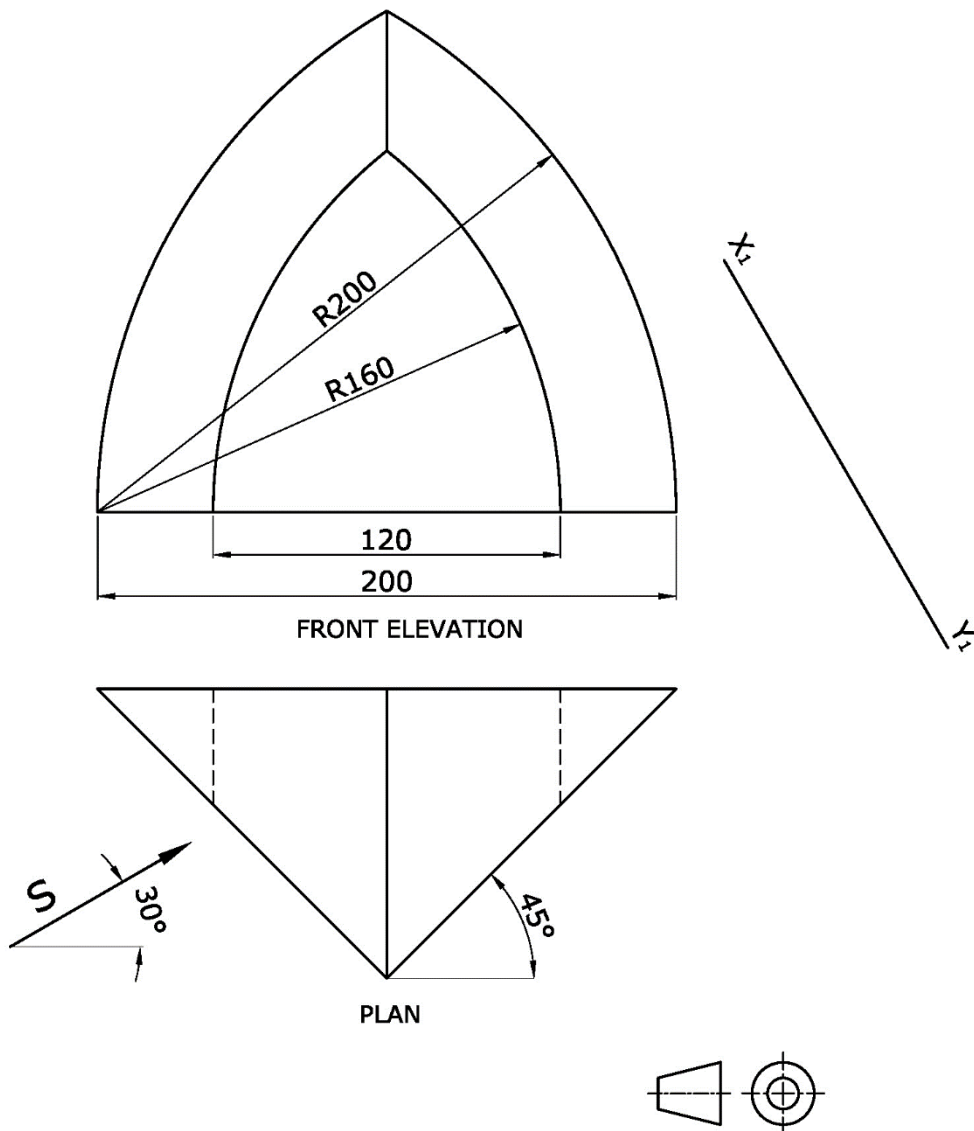

Figure 5b

Question 6

A pictorial view of two intersecting prisms is shown in Figure 6a. The axis of the hexagonal prism is vertical and the axis of the square prism is horizontal. The square prism penetrates the hexagonal prism.

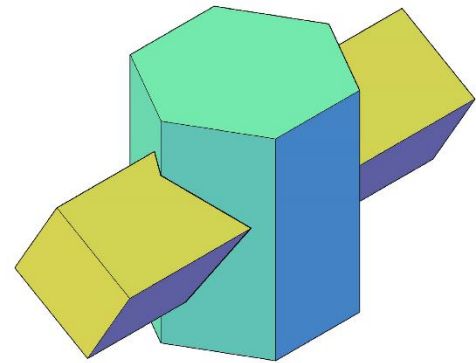

Figure 6a

- a) Copy full size the **THREE** views shown in Figure 6b. (3)
- b) Project, using neat light lines and in the right order, the various points to locate the lines of intersection between the square prism and the hexagonal prism on the front elevation. (6)
- c) Complete the front elevation showing clearly which lines are seen and which lines are hidden. (4)

(Total: 13 marks)

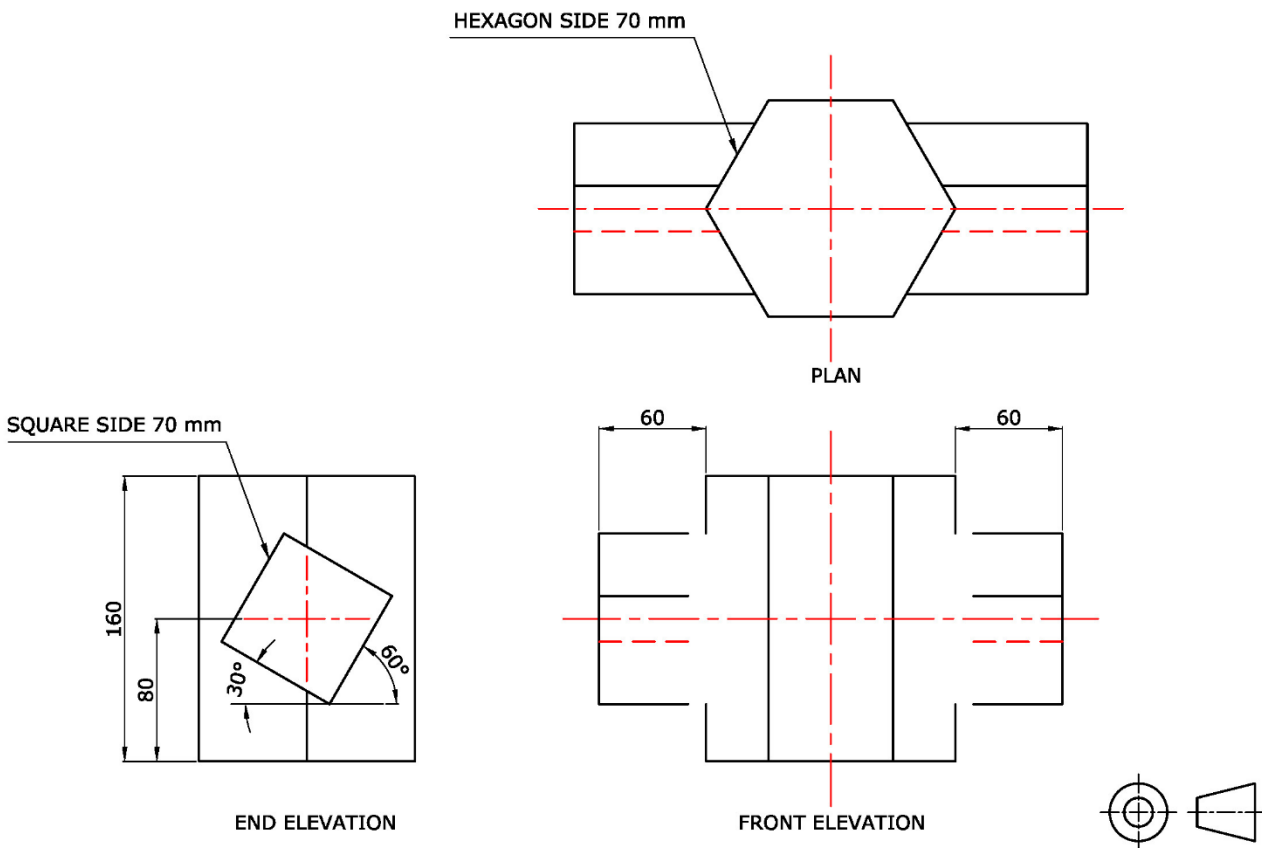

Figure 6b

SECTION B

Attempt only **ONE** question from this section.

Question 7

A drawing of a knuckle joint, with the parts separated from each other is shown in Figure 7a. A knuckle joint is used to connect two round rods. This permits considerable changes in the axial direction of the bars. It may be easily connected and disconnected.

Detailed views of the parts which comprise a knuckle joint are given in Figure 7b on the A3 drawing sheet.

Imagine the parts assembled with the axis of the rods vertical.

- a) Draw an elevation of the assembled knuckle joint showing:
- i. the left - hand half of the end elevation as an outside view; (4)
 - ii. the right - hand half as a sectional end elevation on the section X - X. (6)
- b) Draw an isometric view of the wing nut (Item 3) with the line M - N sloping upwards to the left. (14)

Do **not** include any hidden detail.

(Total: 24 marks)

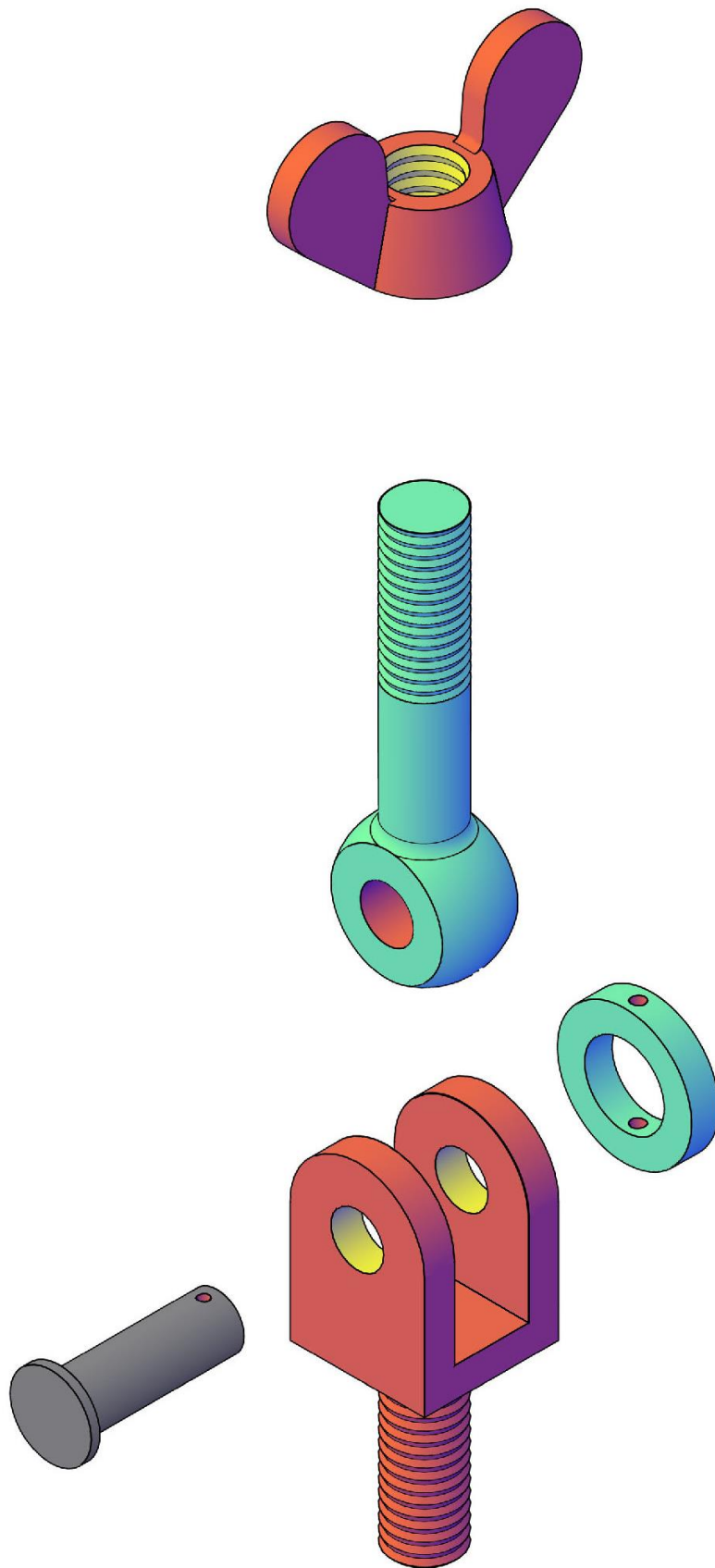

Figure 7a

Question 8

A gear bracket for an engine is illustrated in Figure 8a. Detailed drawing of the component is shown in Figure 8b on the A3 drawing sheet.

Refer to the three dimensional views of the gear bracket shown in Figure 8b and draw full size:

- a) a sectional elevation on the section A - A; (18)
- b) a sectional end elevation on the section B - B. (6)

(Total: 24 marks)

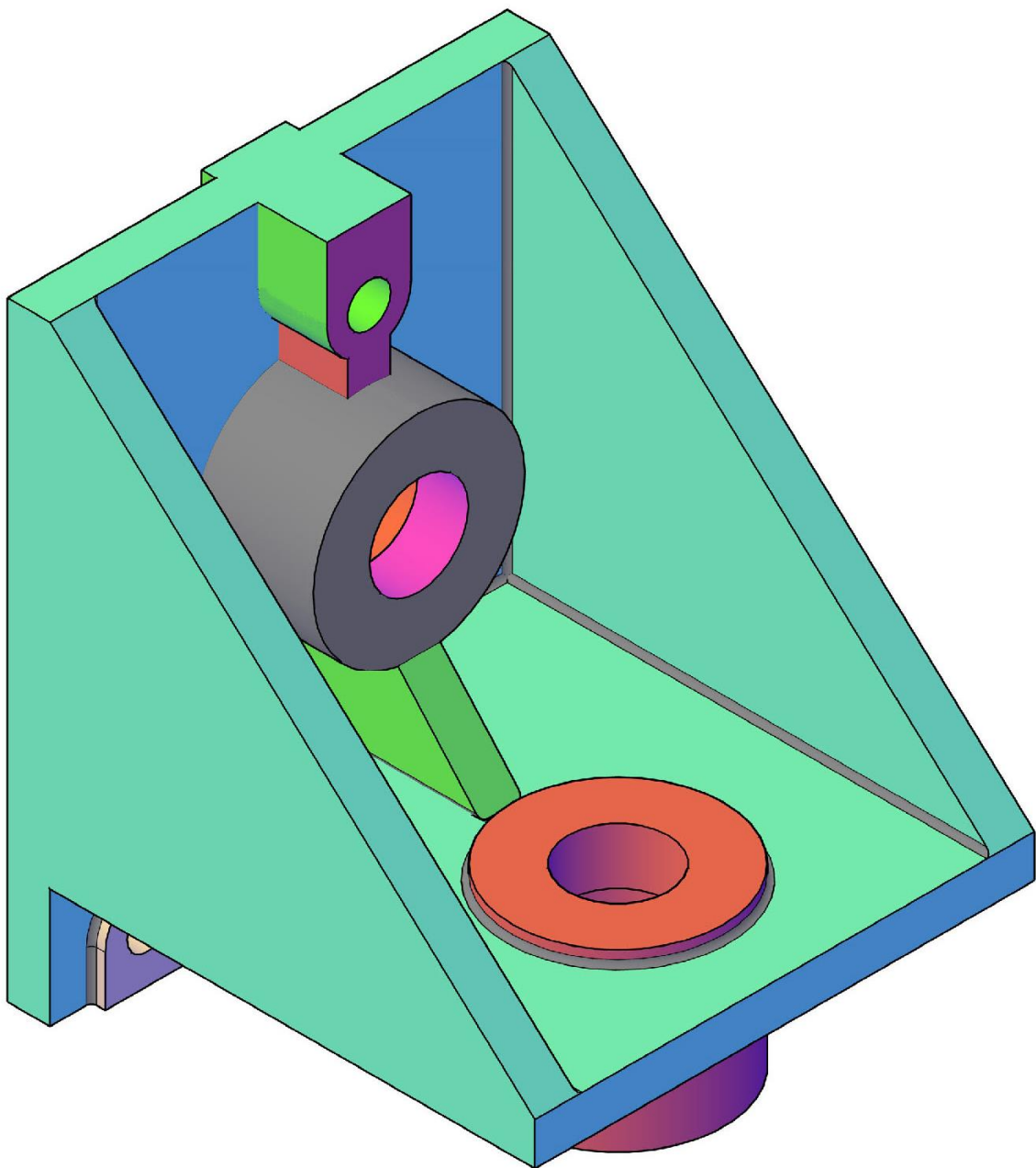

Figure 8a

Question 9

A pictorial view of a particular machine, with the parts pulled apart (exploded view) is shown in Figure 9a.

Detailed dimensioned drawing of the items that when fitted together form an assembly of a manual selector lever mechanism, are shown in Figure 9b, on two attached A3 drawing sheets. The items are assembled in the following manner:

- A handle (Item 1) with a cylindrical tapered knob and an M20 threaded stem, is tightened to the M20 tapped hole of the tapered head swivel (Item 2).
- The swivel (Item 2), with handle (Item 1), is inserted in the 48 mm diameter through hole of the support plate (Item 3), with the 72 mm diameter lower face of the swivel head in contact with the support plate.
- The cam lever (Item 4), 34 mm diameter hole, is fitted in the 34 mm diameter stepped shaft end of the swivel.
- A 6 mm diameter pin (Item 5) is then inserted in the cam lever 6 mm hole, and the aligned hole of the swivel (Item 2). The dowel secures the cam lever to the swivel.
- The assembled handle, swivel and cam lever, are to rotate about the 48 mm diameter hole of the bracket.

Assemble the components shown by

- a) drawing a full-size elevation, showing the front view of the support bracket, with the items included; (6)
- b) projecting a sectional end view on the section X – X, of the complete assembly as seen from the left-hand side. (18)

Do **not** include hidden details.

(Total: 24 marks)

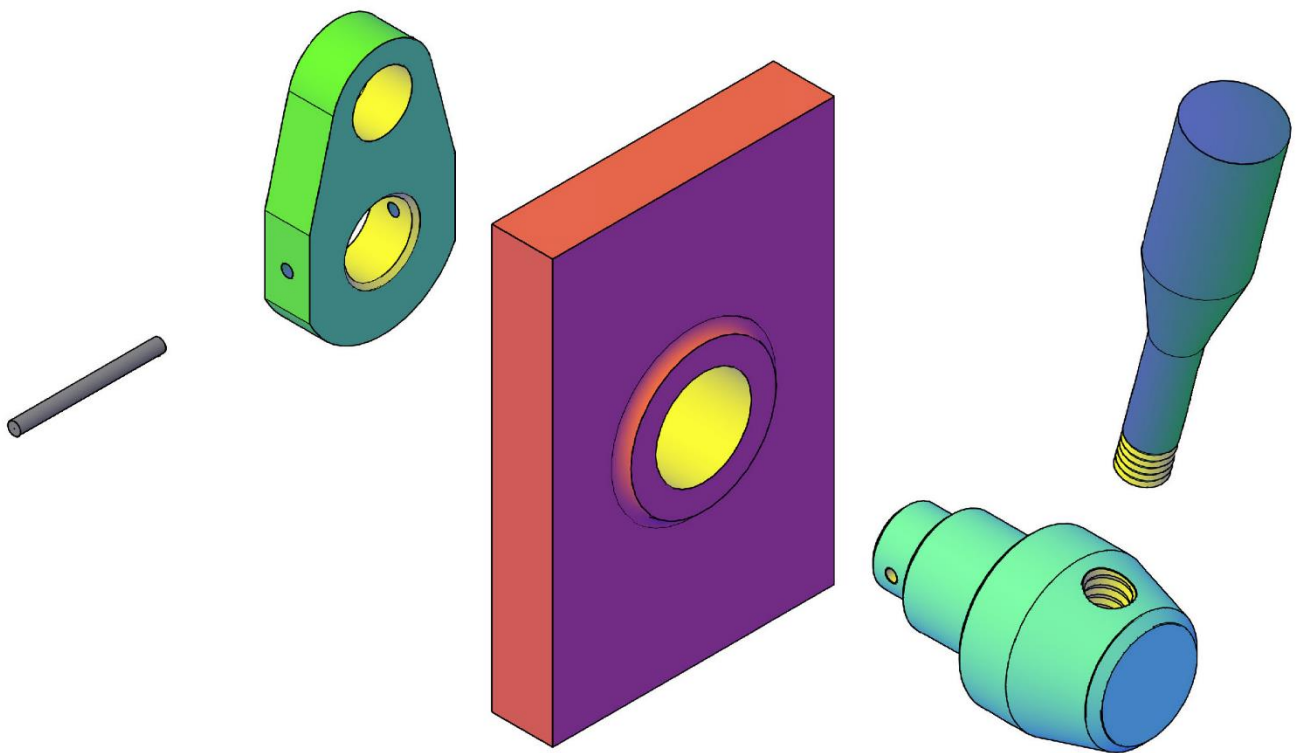

Figure 9a

SECTION C

Attempt only **ONE** question from this section.

Question 10

An isometric drawing of a storage garage is shown in Figure 10a. An orthographic projection of the storage garage is shown in Figure 10b. The storage garage consists of a large free standing wood shelving, four horizontal wall mounted wood shelves, a long cabinet with doors and drawers and a tall cabinet with doors.

- a) Use the dimensions given in the orthographic projection to construct an estimated one-point perspective of the storage garage. The viewing direction required is indicated by the arrow in the plan. Use the suggested vanishing point shown in Figure 10c. (21)
- b) Render in colour your drawing to enhance its presentation. (3)

(Total: 24 marks)

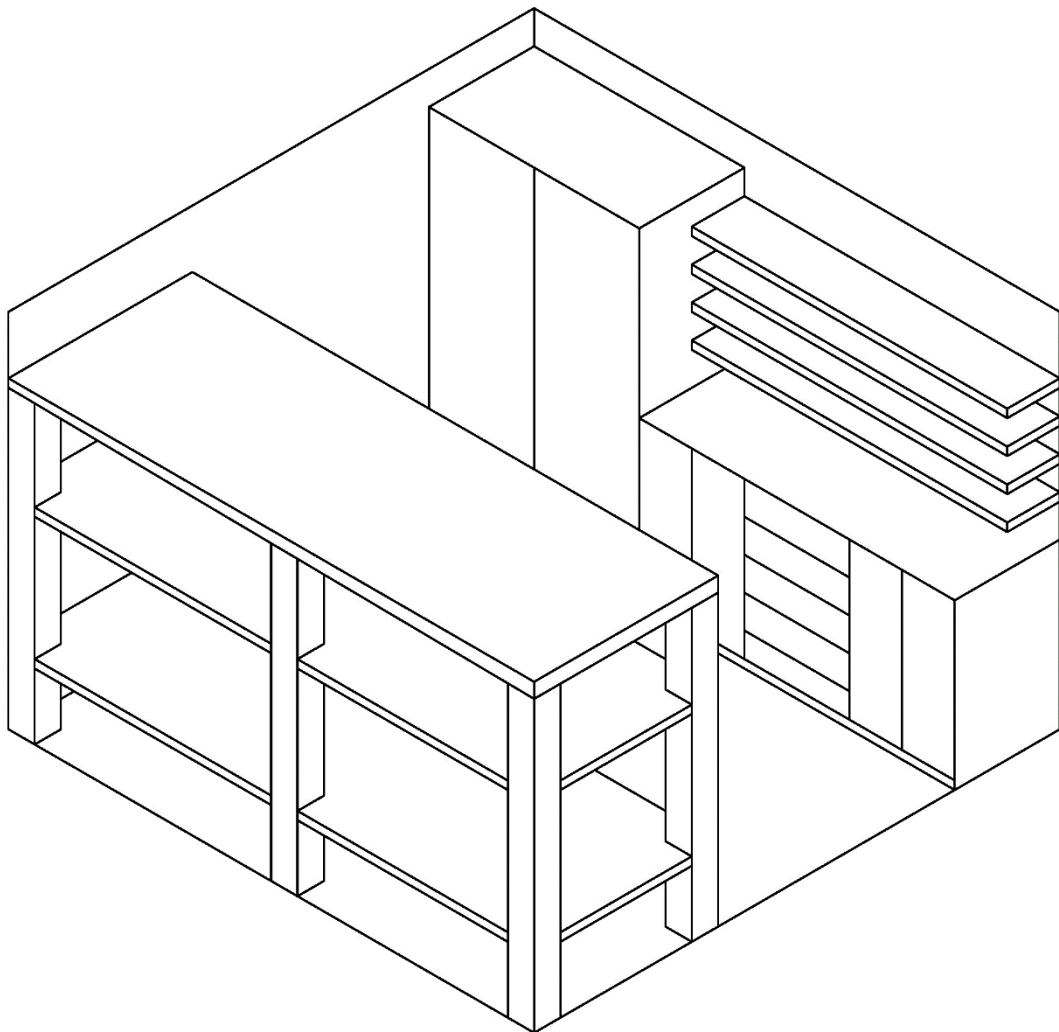
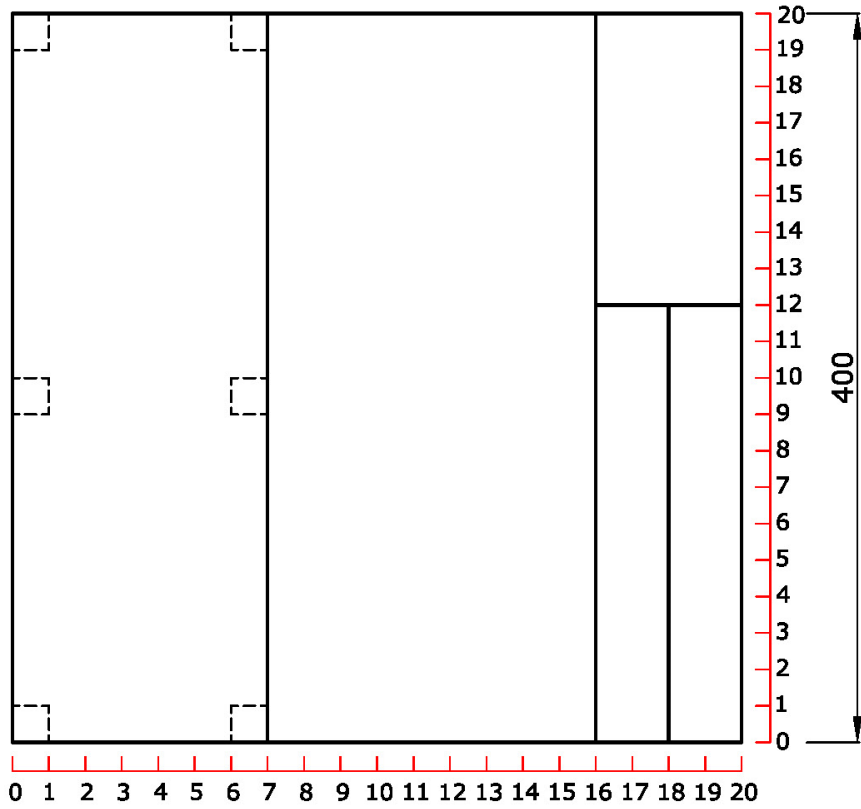
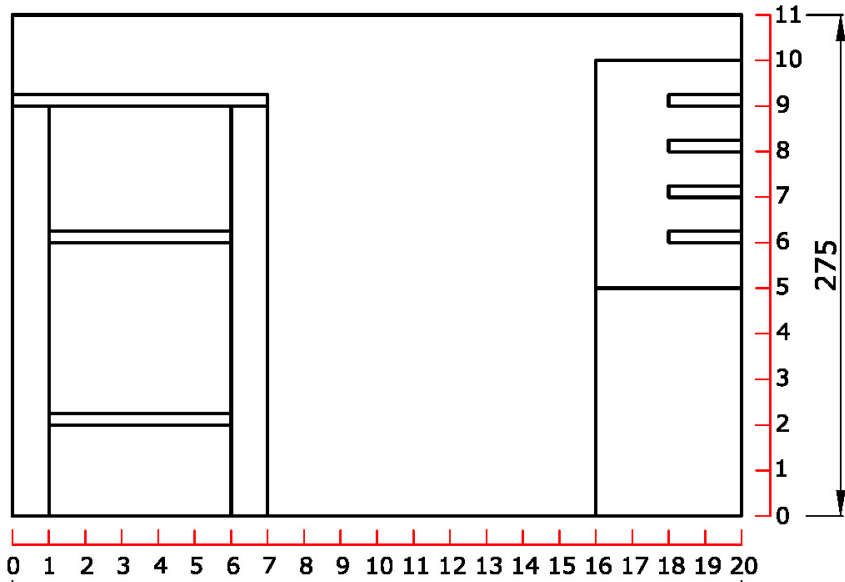

Figure 10a



PLAN

↑
Viewing direction



400
FRONT VIEW

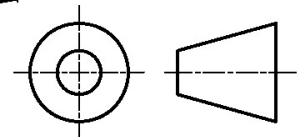

Figure 10b

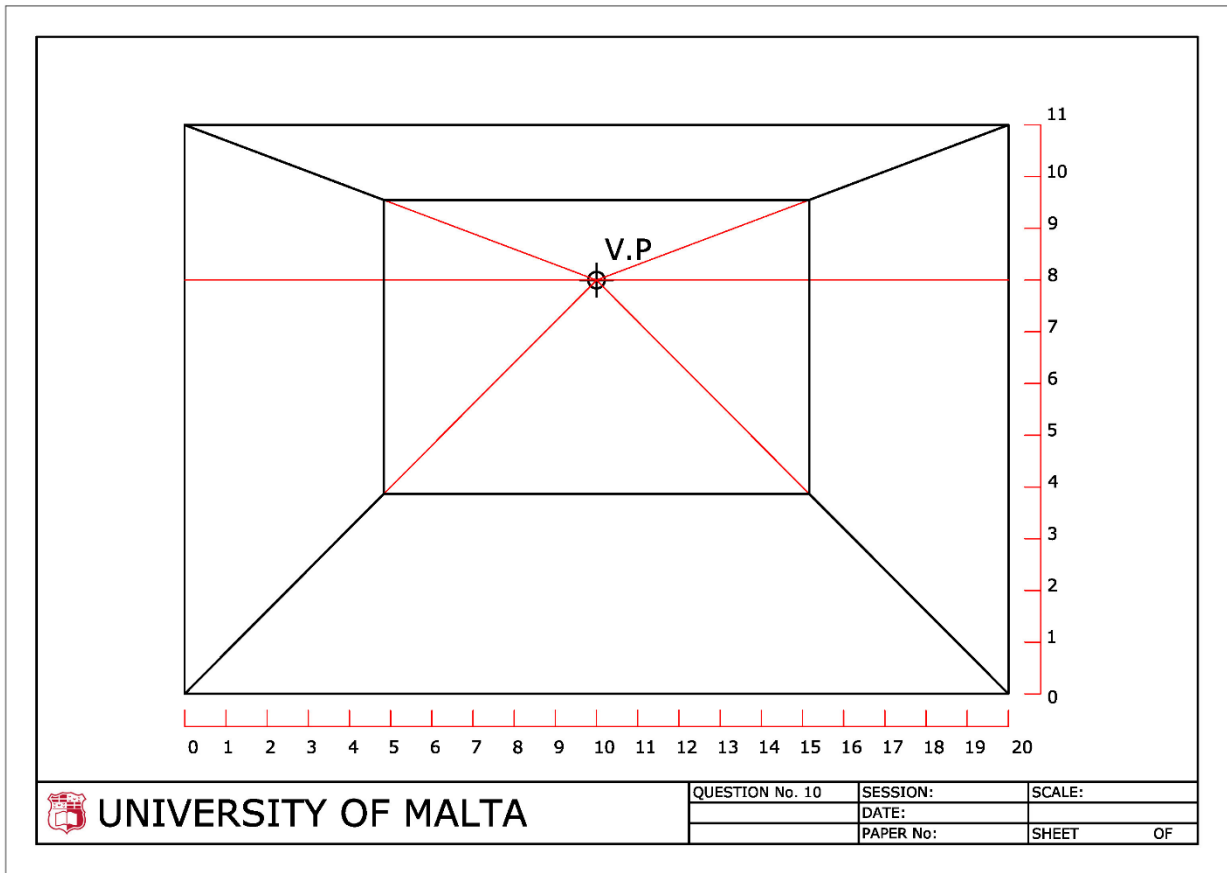

Figure 10c

Question 11

An isometric drawing of a chicken coop inside a small barn is shown in Figure 11a. An orthographic projection of the chicken coop is shown in Figure 11b. The chicken coop consists of wooden nesting boxes with a sloping roof, three horizontal wall mounted wood shelves for storage and a wall mounted wooden box.

Use the dimensions given in the orthographic projection to construct an estimated two - point perspective of the chicken coop. The viewing direction required is indicated by the arrow in the plan. Use the suggested layout of the two - point perspective shown in the Figure 11c. (21)

Render in colour your drawing to enhance its presentation. (3)

(Total: 24 marks)

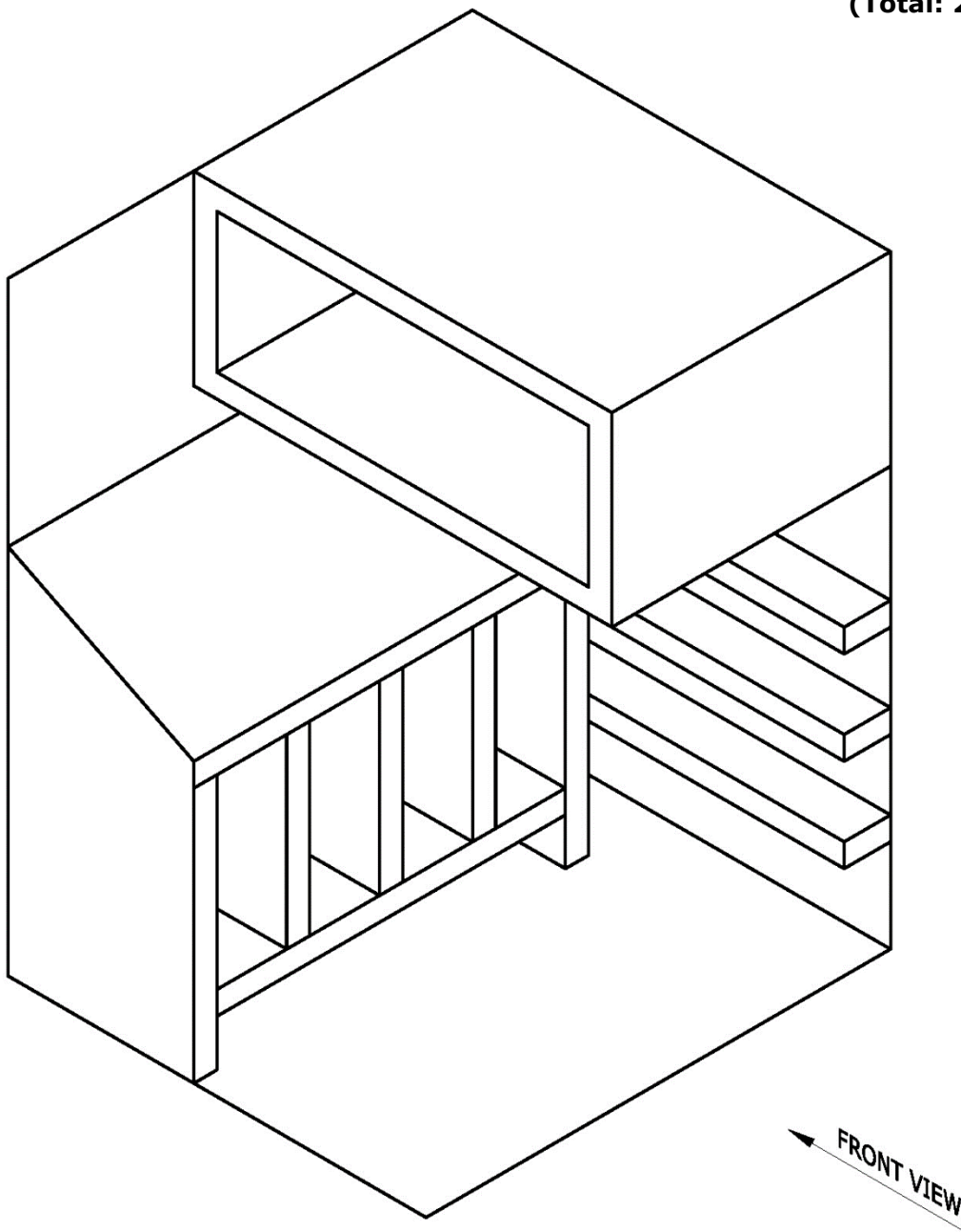

Figure 11a

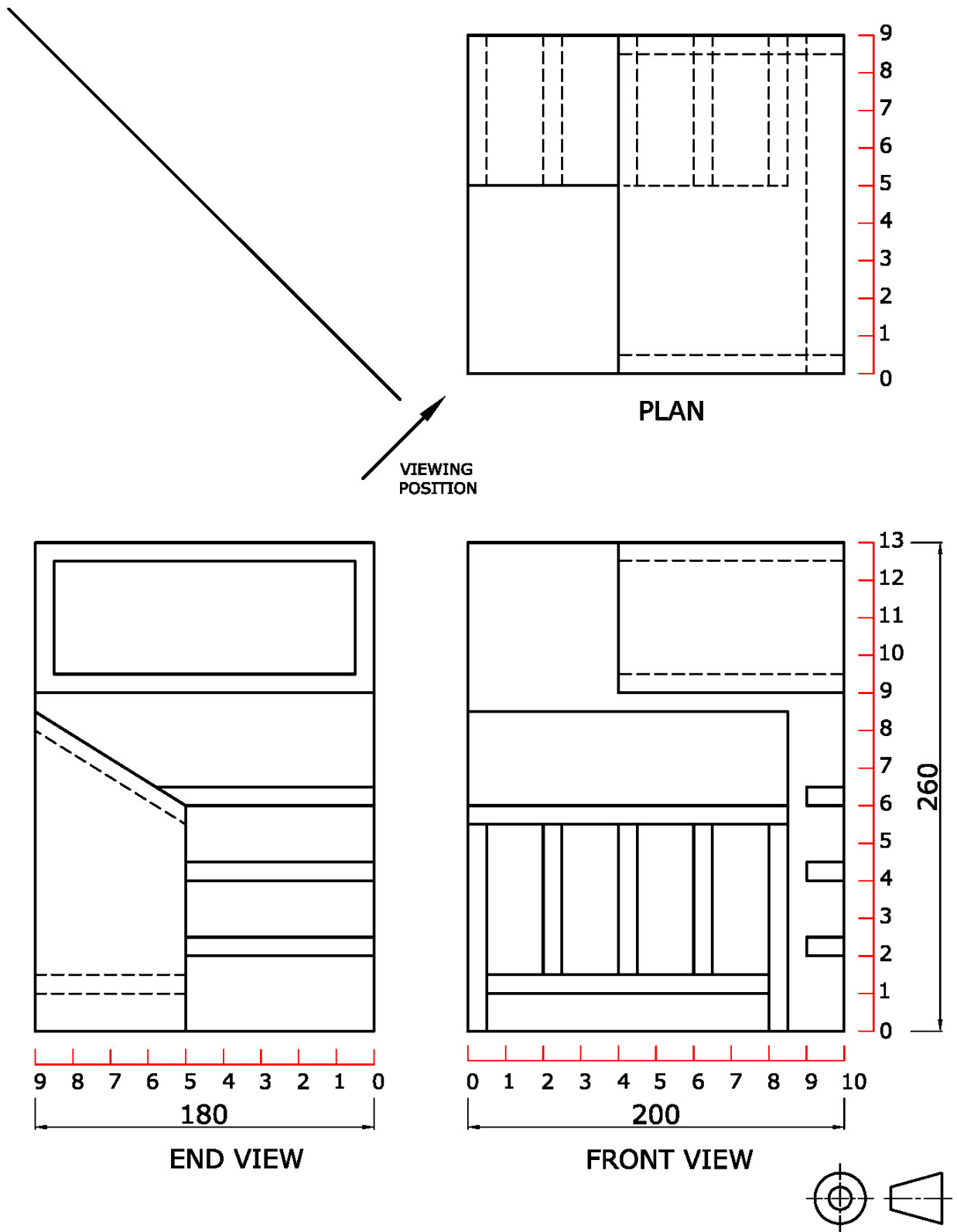

Figure 11b

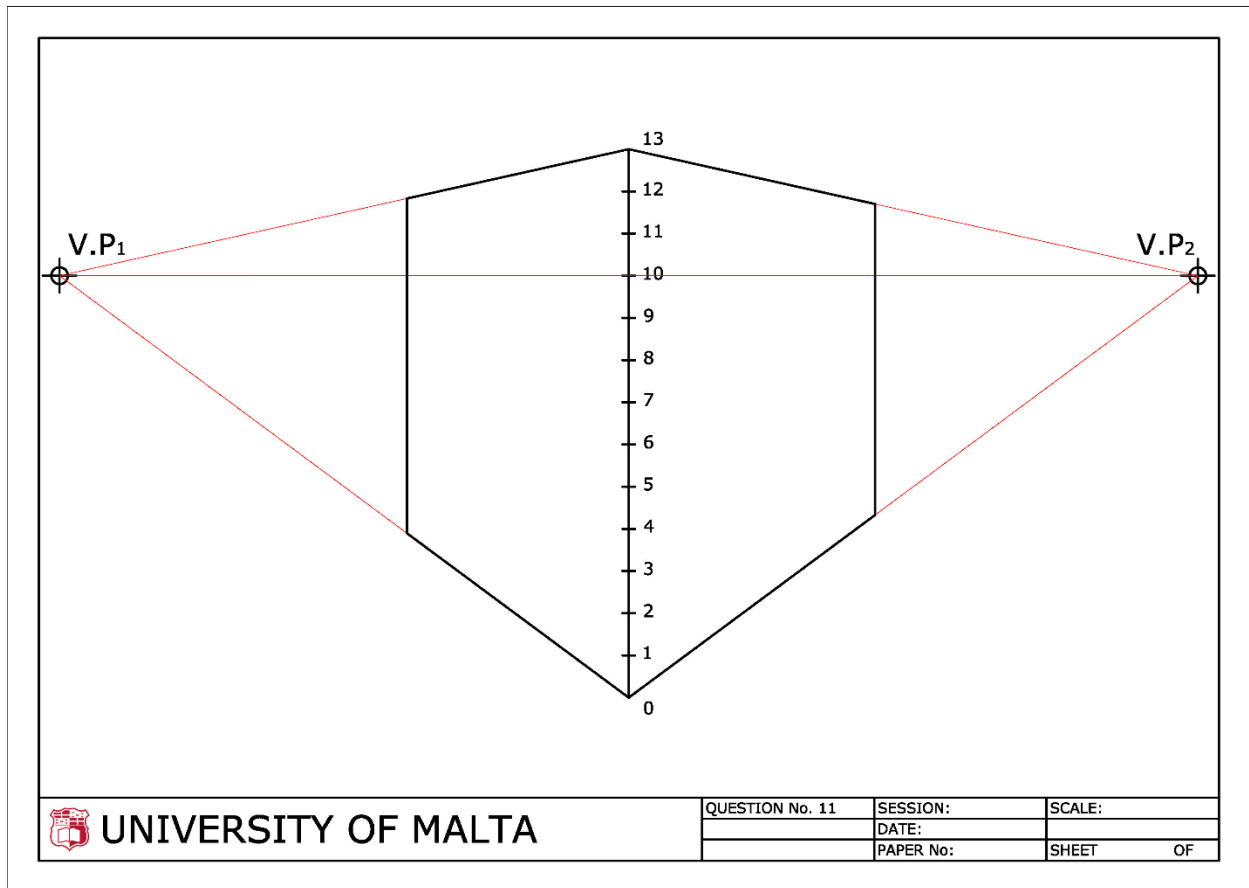

Figure 11c

Question 12

An English language teaching school, 'Speak English Fluently' wants to host and teach English to foreign students in the Maltese Islands. Additional to hosting and teaching, the school wants to offer a range of leisure and educational services inside their premises. The school started analysing data published by Malta National Statistics Office, shown in Table 12.1. Note that all data was rounded to the nearest hundred.

Table 12.1: Foreign students following courses in local licensed English Language Teaching (ELT) schools by year, sex and country of citizenship.
[NSO Teaching English as a Foreign Language 2020]

Country of citizenship	2019			2020		
	Males	Females	Total	Males	Females	Total
Germany	4,100	5,600	9,700	1,000	1,700	2,700
France	3,400	5,500	8,900	700	1,000	1,700
Italy	8,200	10,200	18,400	700	900	1,600
Spain	1,500	2,300	3,800	600	700	1,300

You are required to design a poster. Your presentation must follow the steps given below and organised as suggested in Figure 12a.

- Label the poster with the heading "Speak English Fluently". (2)
- Draw **THREE** pictograms to be used for the location of services the school wants to offer inside their premises. Choose from: Rooftop terrace, kitchen area, computer lab, library, lounge, and student support desk. Sketches to develop ideas can be drawn at the side of your A2 sheet. (8)
- Draw a 2D bar chart on your poster showing the number of foreign males and females students following courses from Germany, France, Italy and Spain in 2019. Label this bar chart clearly showing **all** the necessary information. (6)
- Draw a 2D pie chart showing the total number of students following from Germany, France, Italy and Spain in 2020. Label this pie chart clearly showing **all** the necessary information. (6)
- Finalise your designed poster. The poster is expected to have a visual impact and carry the intended message clearly. (2)

Special consideration is to be given to the following accomplishment:

- the use of colour and shading to render the drawing;
- the use of typography (fonts);
- the clarity in conveying the information.

(Total: 24 marks)

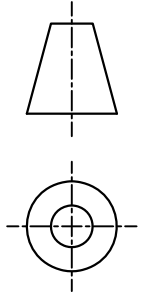
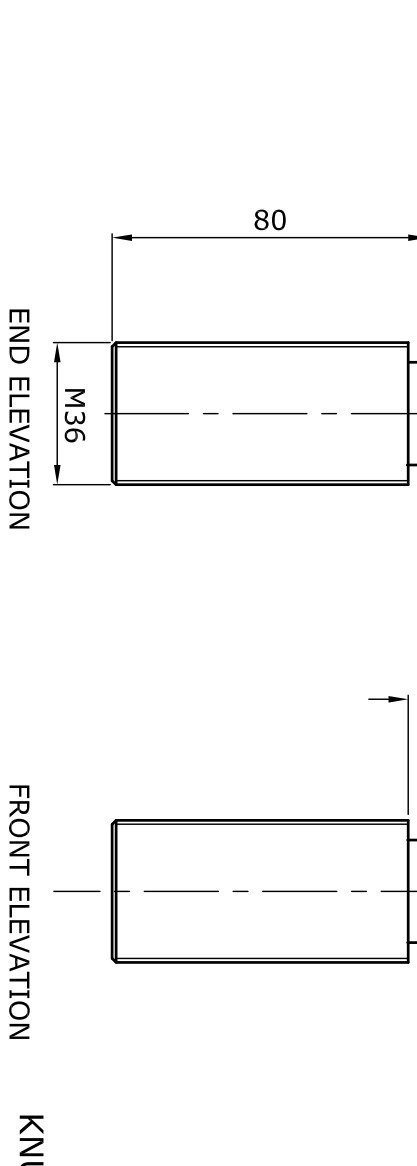
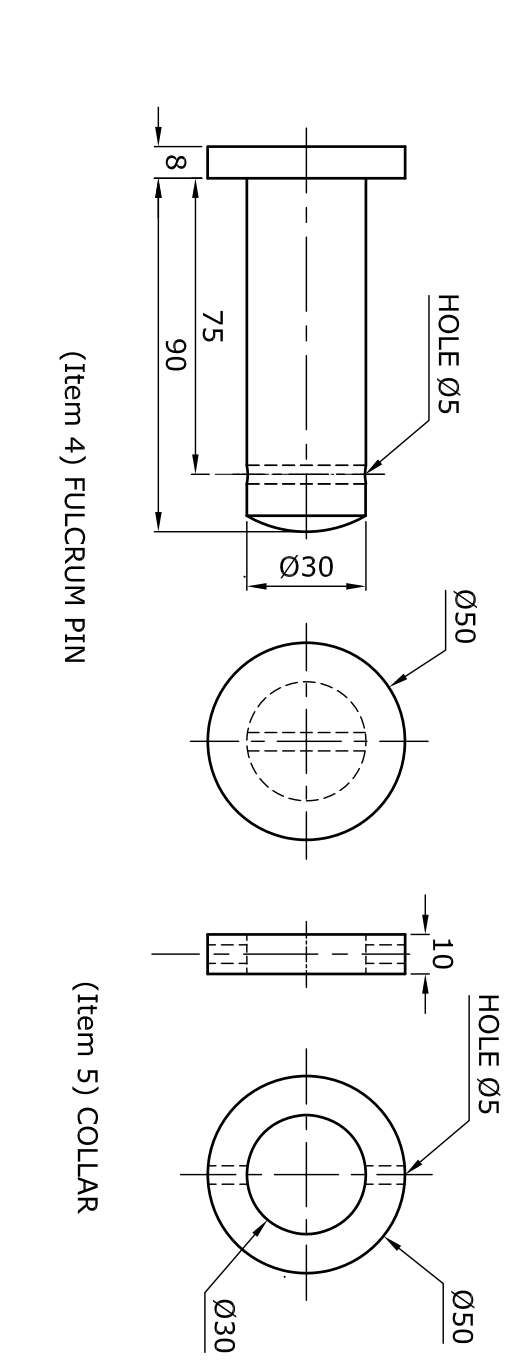
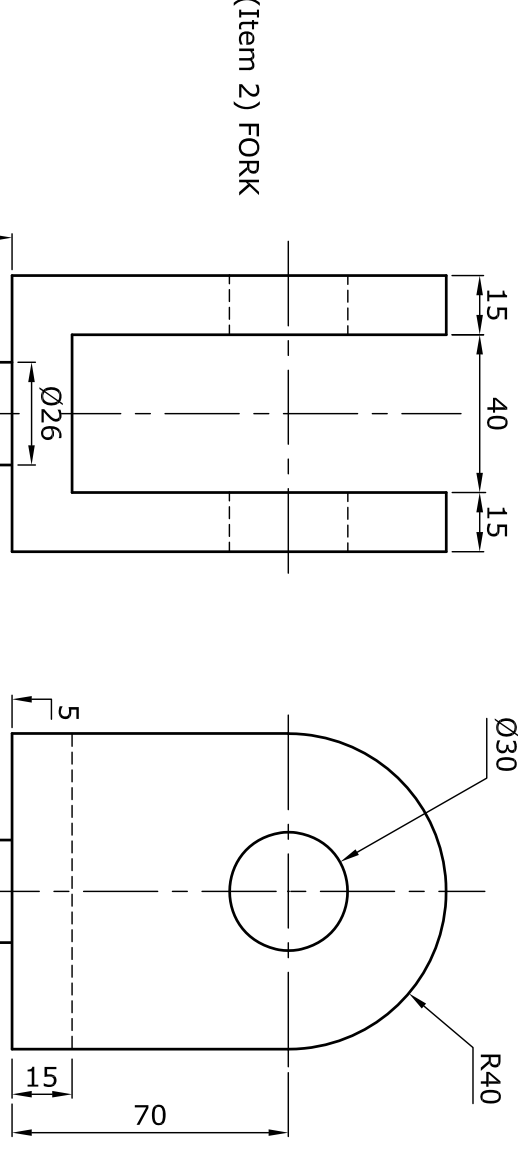
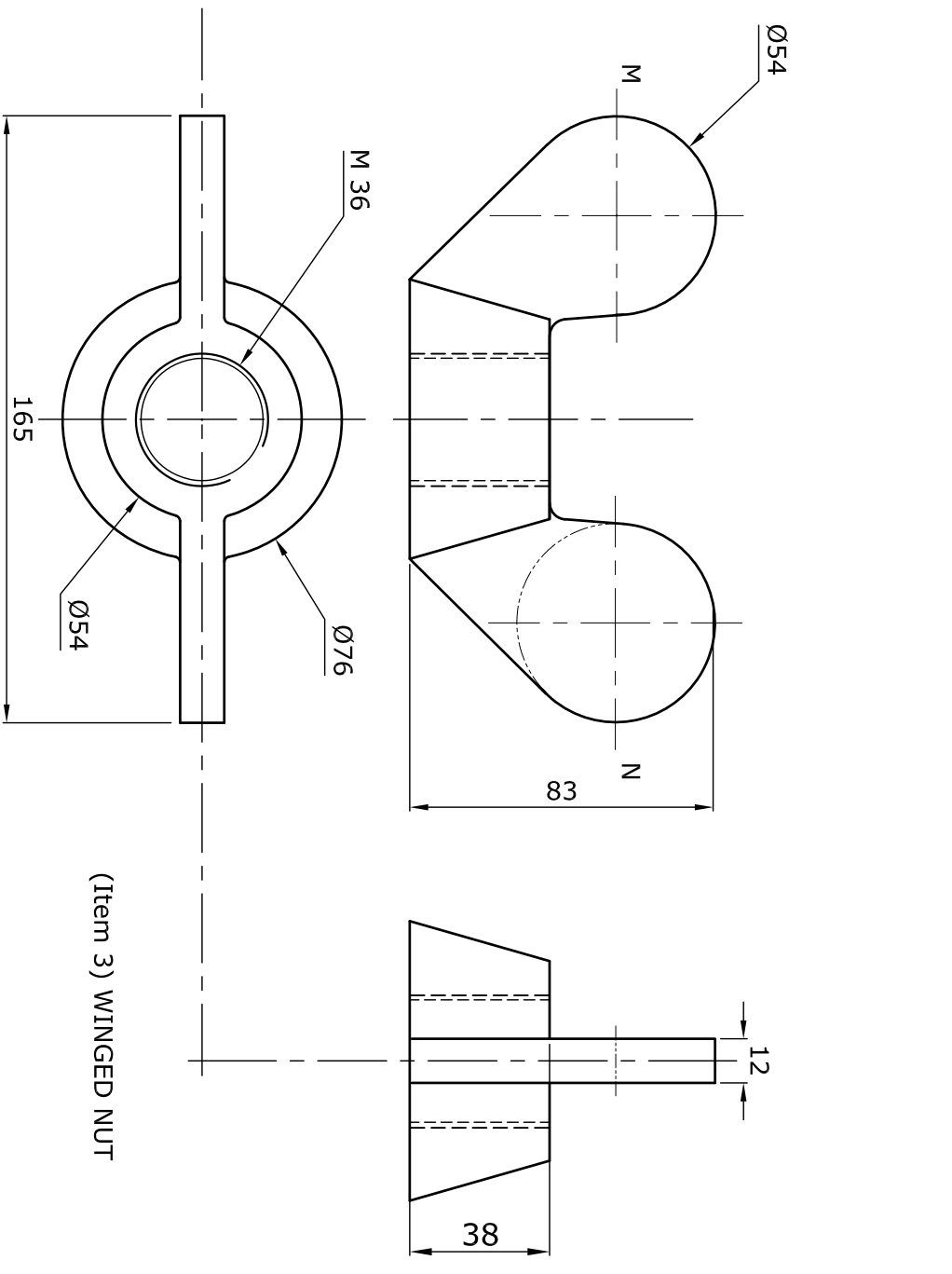
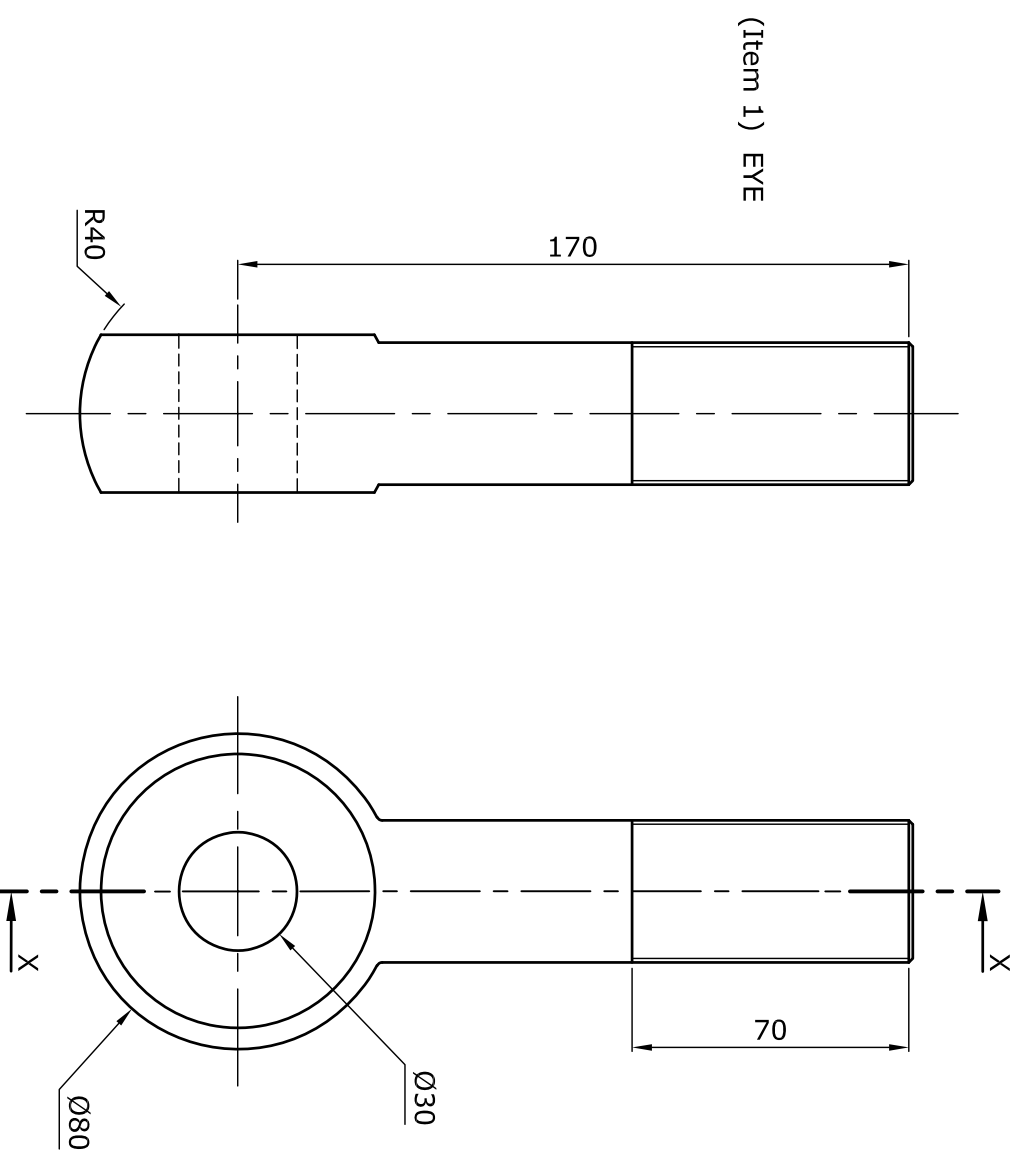

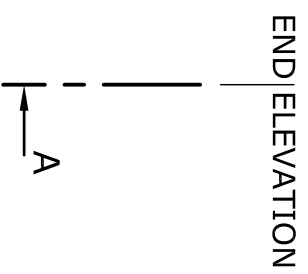
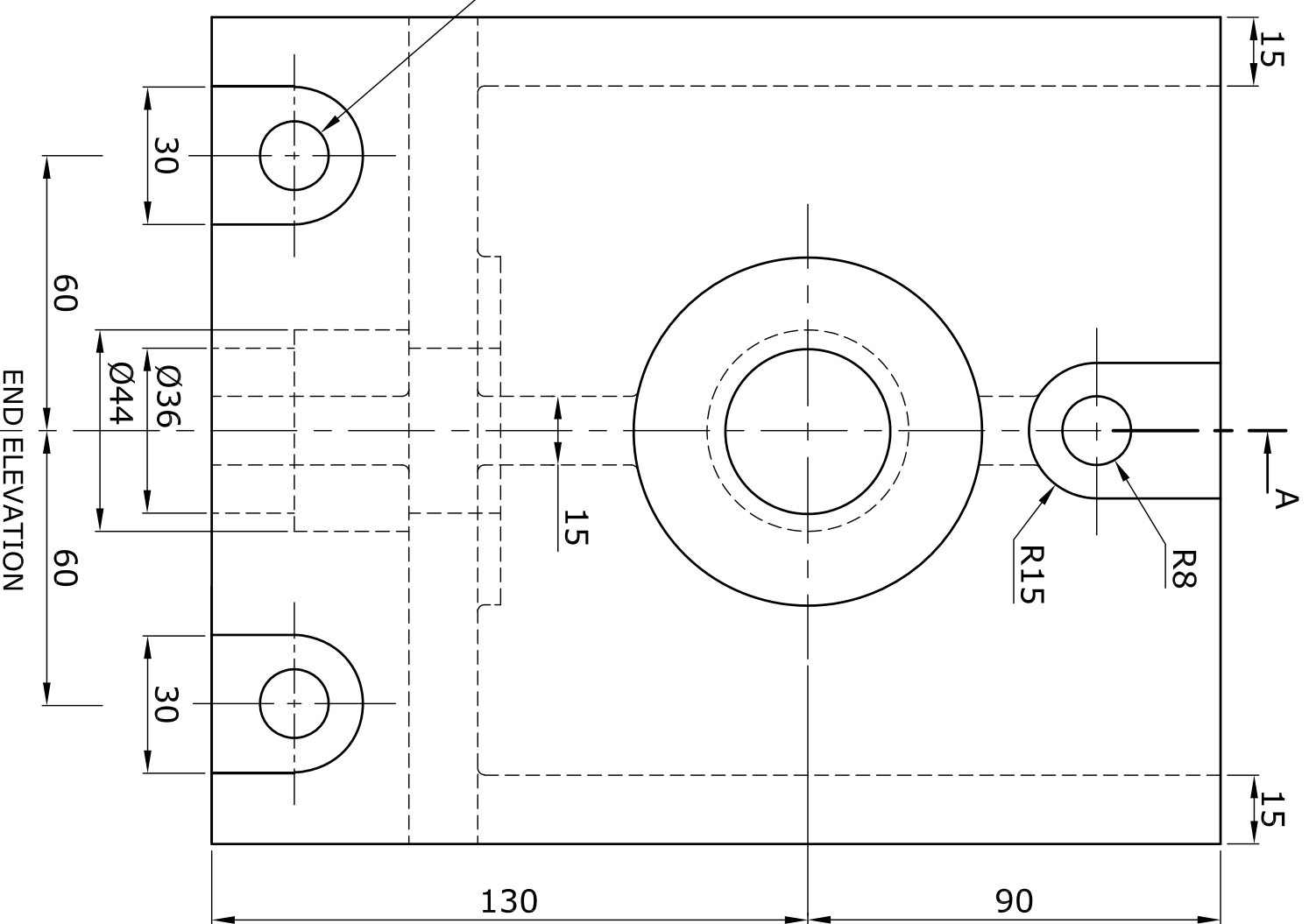
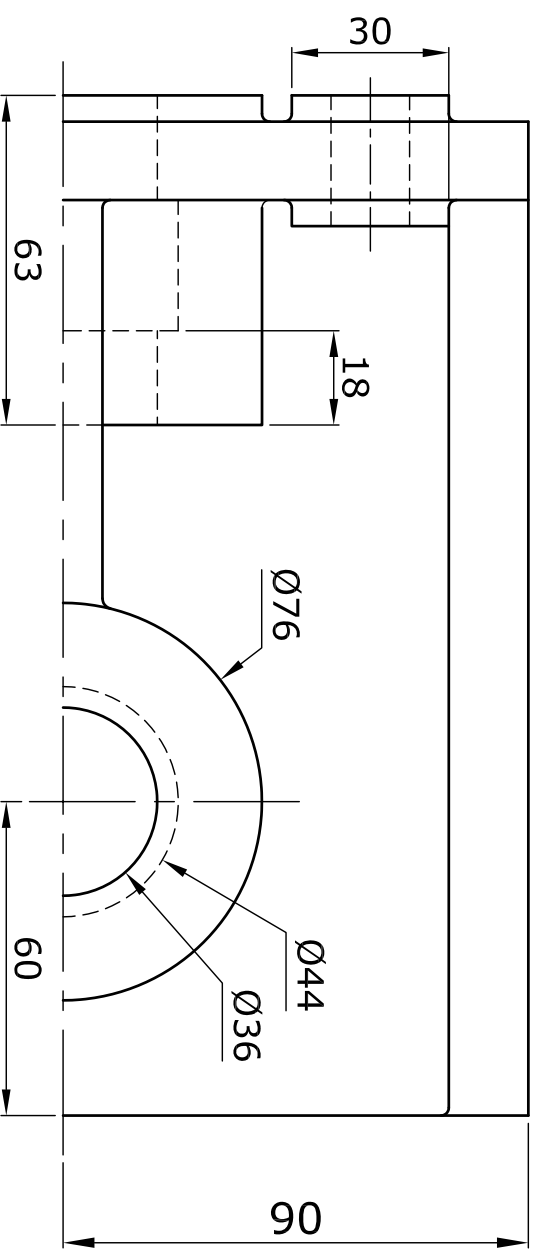
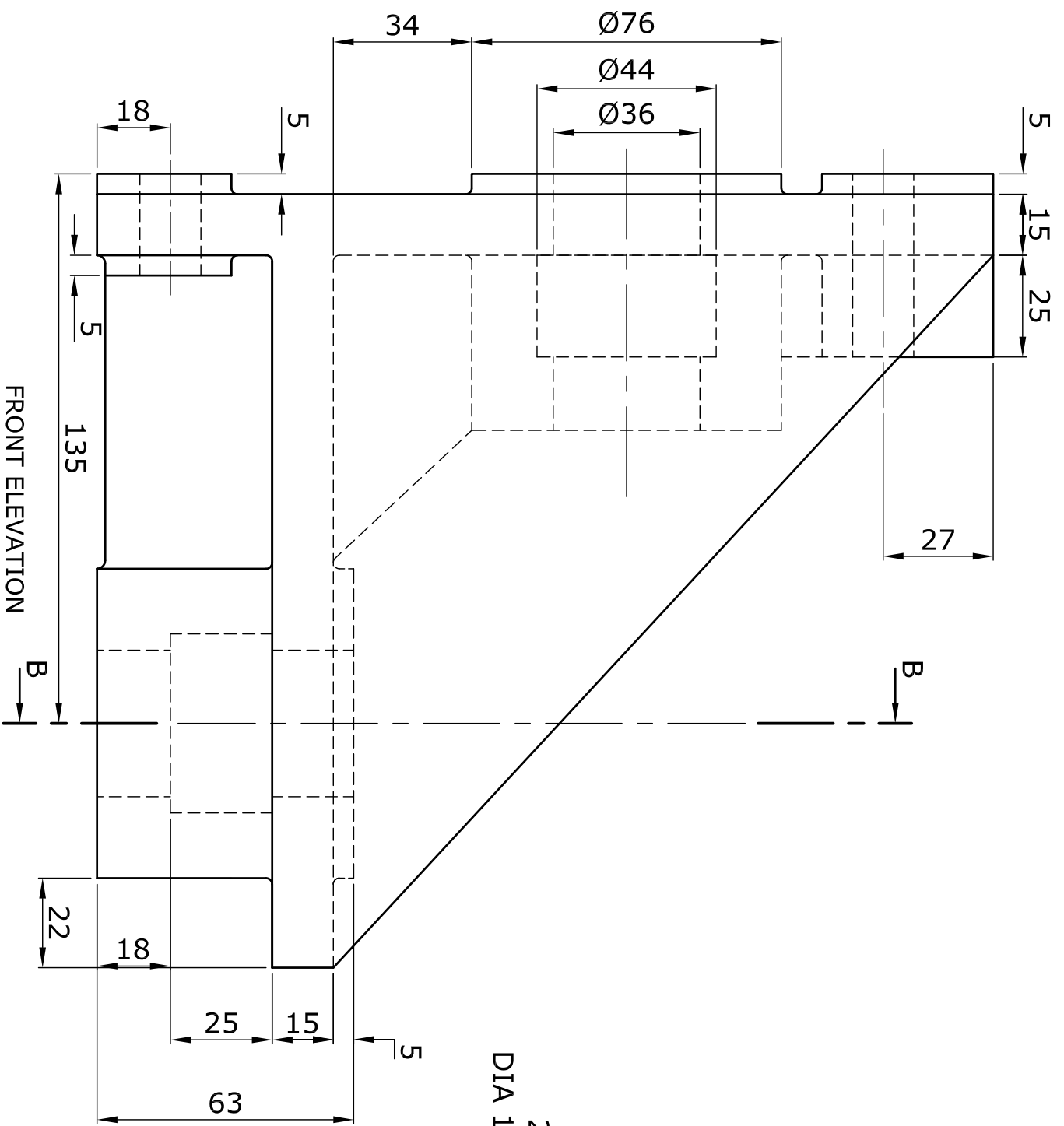

GEAR BRACKET

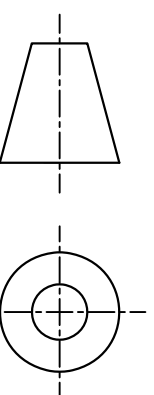

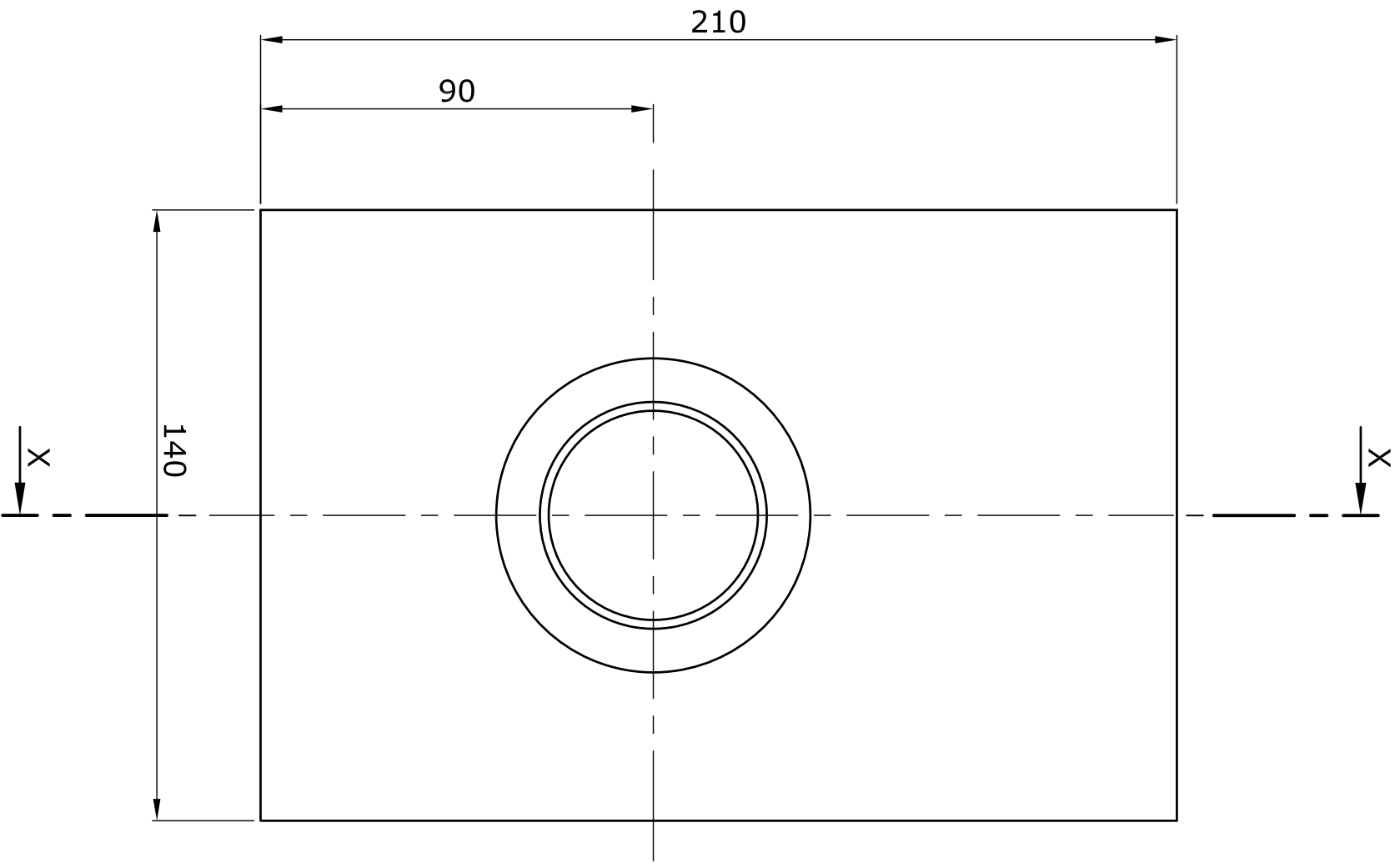

(ITEM 3) SUPPORT PLATE

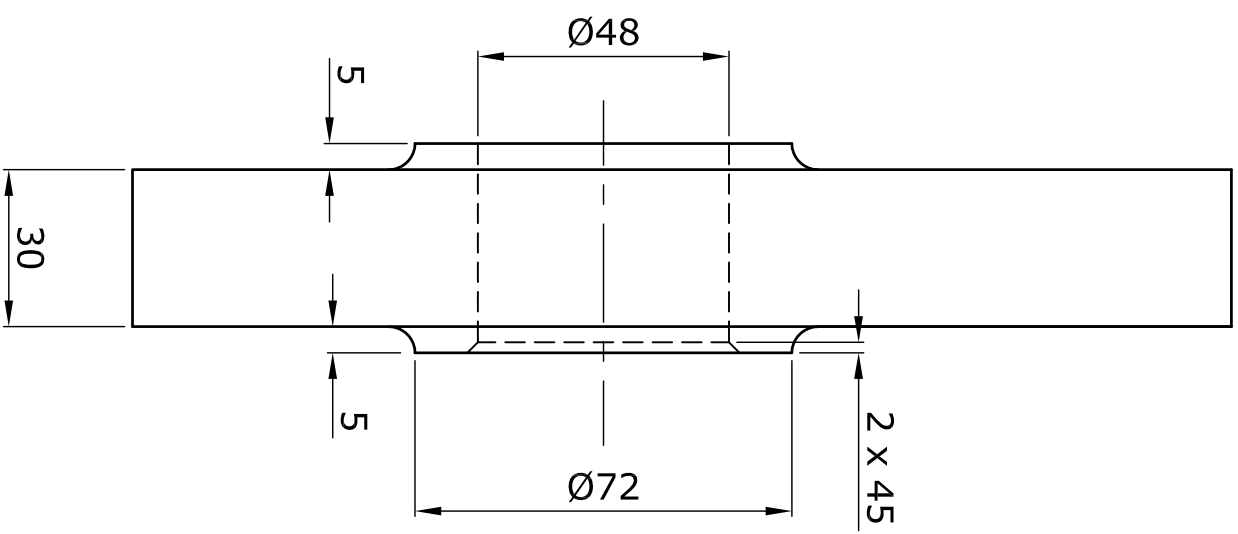

(ITEM 2) SWIVEL

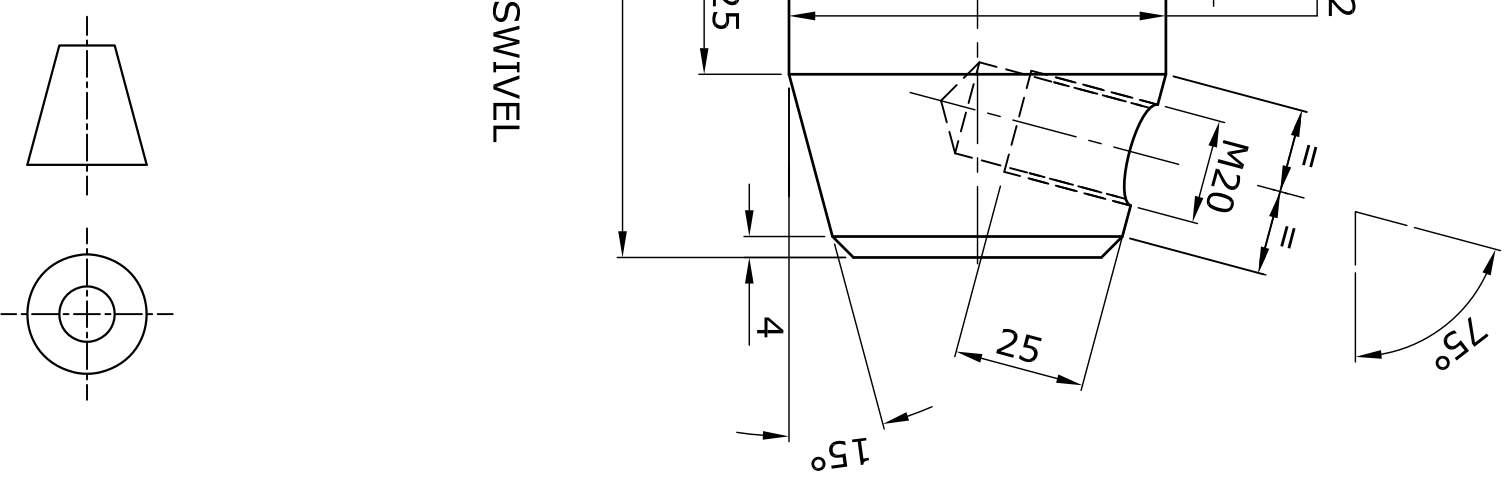

MANUAL SELECTOR

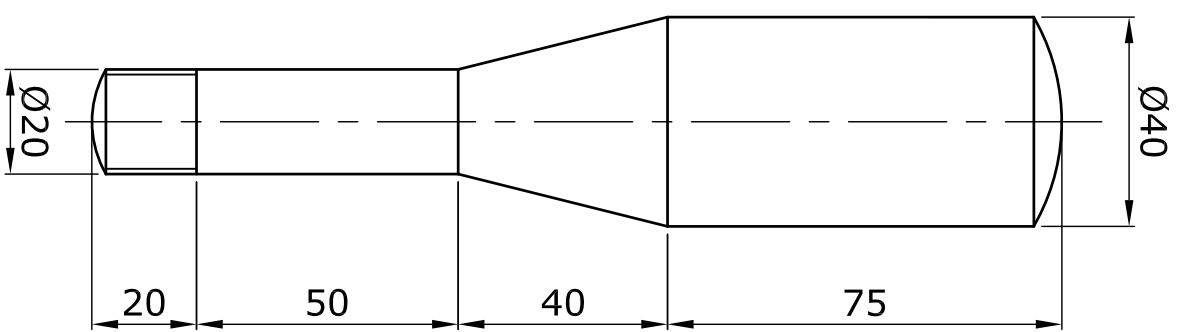

(ITEM 1) HANDLE

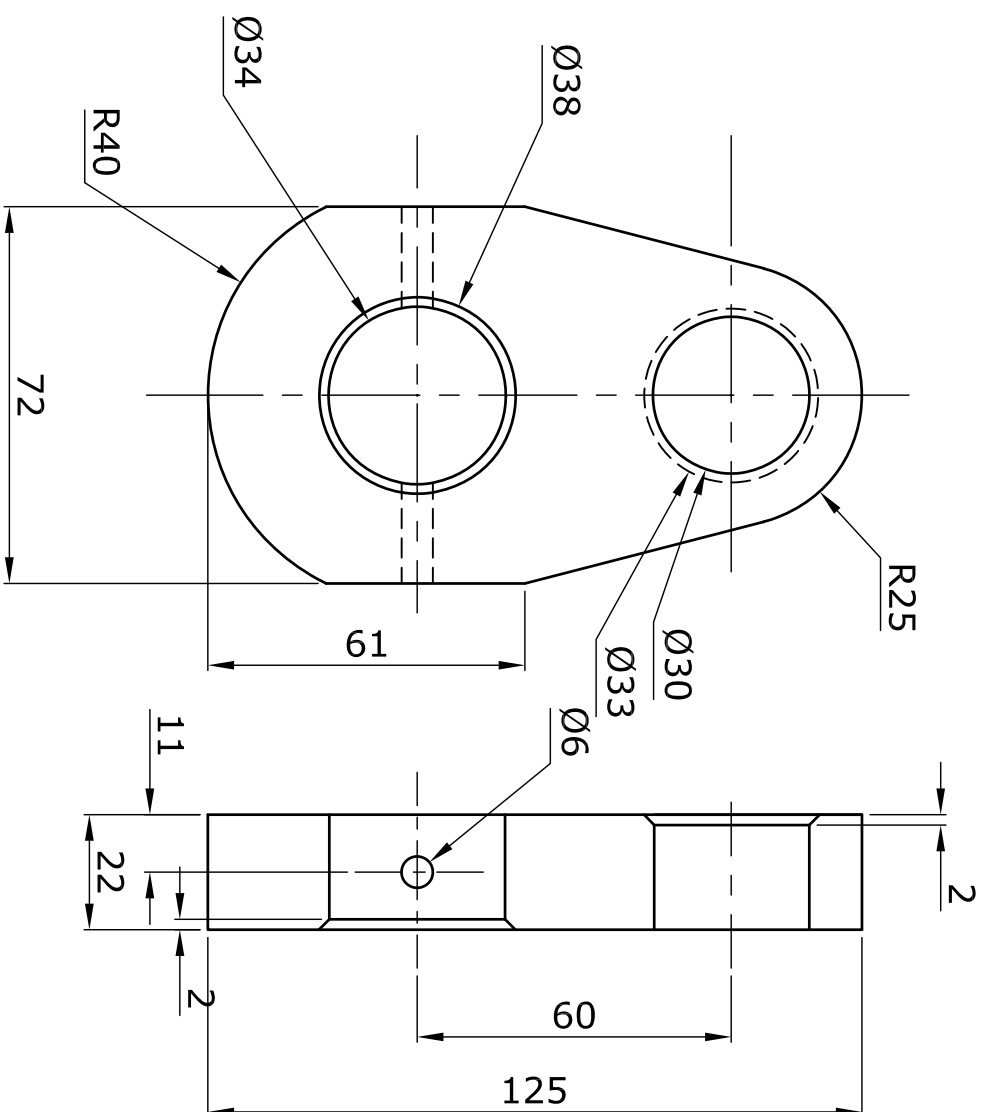

(ITEM 4) CAM LEVER

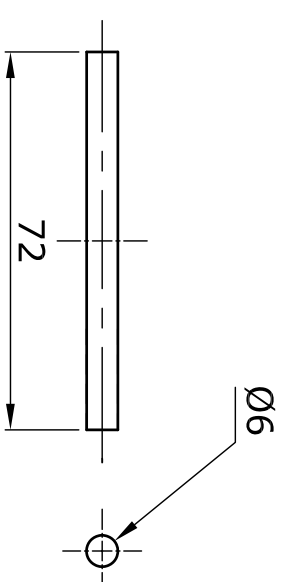

(ITEM 5) PIN

MANUAL SELECTOR

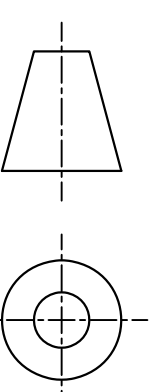

sheet 2 of 2