



| | |
|----------|--|
| SUBJECT: | Engineering Drawing and Graphical Communication |
| DATE: | 31 st May 2022 |
| TIME: | 4:00 p.m. to 7:05 p.m. |

Directions to Candidates

Write your index number where indicated at the top of all drawing sheets.

Only scientific calculators may be used. Programmable calculators are not allowed.

Unless otherwise stated:

- B.S. or equivalent (ISO) recommendations should be adopted throughout your answers;
- all dimensions are in millimetres, unless otherwise stated;
- all answers are to be accurately drawn with instruments;
- all construction lines must be left in each solution;
- drawing aids may be used.

Dimensions not given should be estimated.

Careful layout and presentation are important.

Marks will be awarded for accuracy, clarity and appropriateness of constructions.

Colour/shading may be used where appropriate.

Section A: Attempt any **FOUR** questions from six.

Section B: Attempt any **ONE** question from three.

Section C: Attempt any **ONE** question from three.

SECTION A

Attempt any **FOUR** questions from this section.

Question 1

Two point loads at the free end of a steel beam and a load at the centre of the supports are shown in Figure 1a and in Figure 1b.

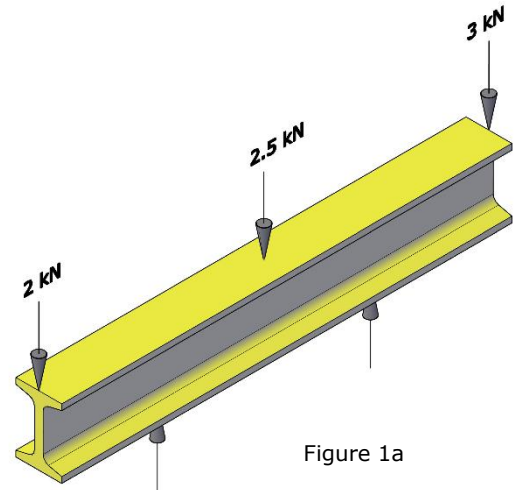

Figure 1a

- a) Copy the given Figure 1b using the scale shown and annotate using Bow's notation. (2)
- b) Include a vector and polar diagram using a scale of 20 mm representing 1 kN. (2)
- c) Construct a funicular polygon. (4)
- d) State the position of the resultant / equilibrant from the left end of the beam. (1)
- e) Find graphically the magnitude of the left and right support. (3)
- f) Complete a shear force diagram. (1)

(Total: 13 marks)

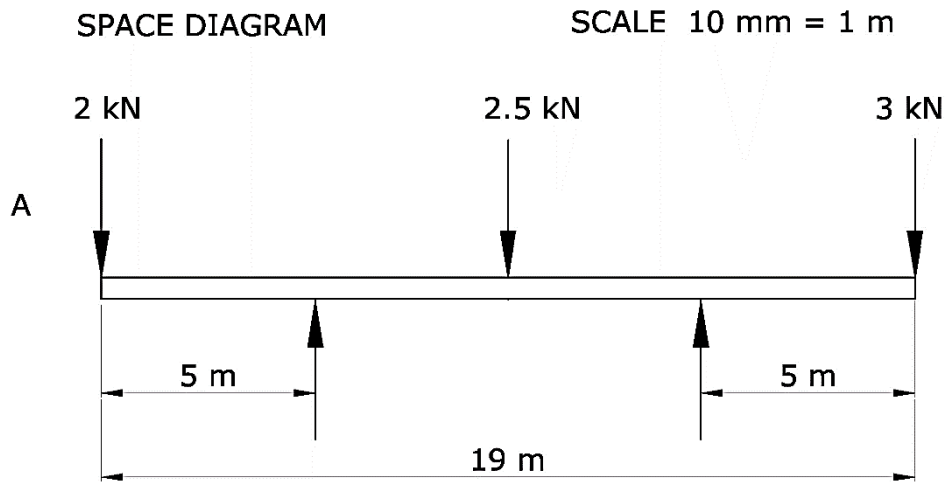

Figure 1b

Question 2

A truncated square pyramid is welded to a hexagonal prism base forming a cast iron stand as shown in Figure 2a.

- a) Copy, full size, the given front elevation shown in Figure 2b. (1)
- b) Complete the plan view of that part of the stand below the section plane A-A. (4)
- c) Construct the auxiliary plan for the section A-A. (8)

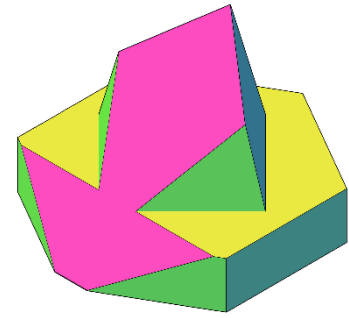

Figure 2a

(Total: 13 marks)

Do **not** show hidden detail.

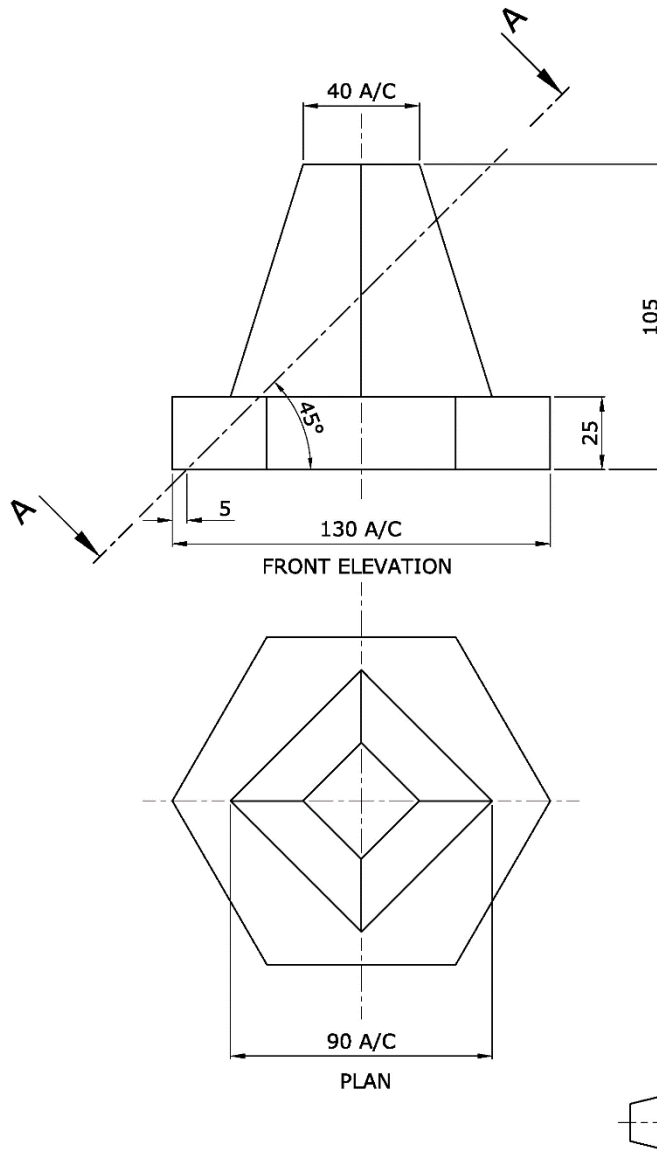

Figure 2b

Please turn the page.

Question 3

A round bar is machined to the specific requirements, as shown in Figure 3a.

- a) Copy, full size, the elevation and plan of the cylindrical solid, shown in Figure 3b. (2)
- b) Project an end elevation in the direction of the arrow S. (6)
- c) Construct the surface development of the curved surface between A and B. (5)

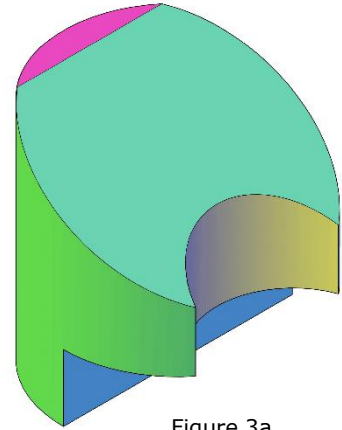

Figure 3a

(Total: 13 marks)

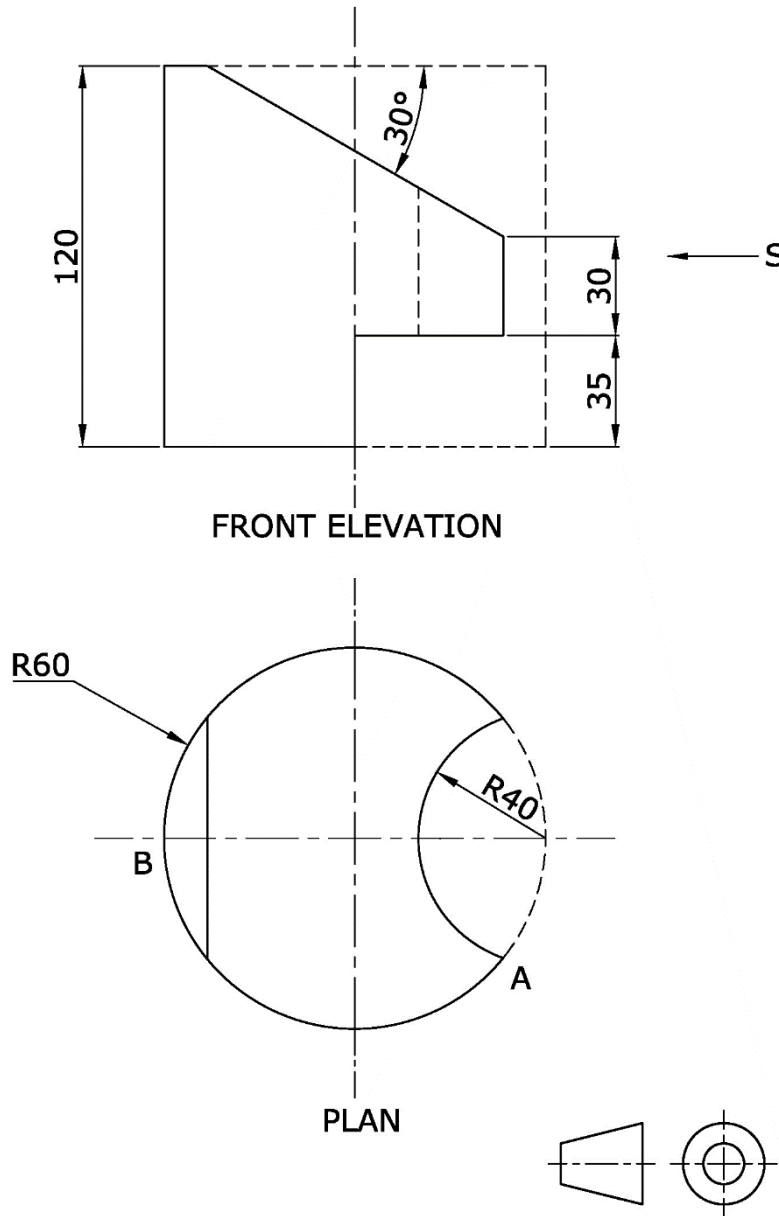

Figure 3b

Question 4

An illustration of a cut oblique cone is shown in Figure 4a. The oblique cone sectioned by a curved plane is shown in the orthographic views presented in Figure 4b. The oblique cone is manufactured from sheet metal.

- a) Copy, full size, the two given views in Figure 4b showing the necessary construction for the cut in the plan. (4)
- b) Show clearly the method used to find the required true lengths, to construct the pattern of the resulting lower part of the oblique cone. (4)
- c) Construct half the surface development of the frustum of the oblique cone using the triangulation method. (5)

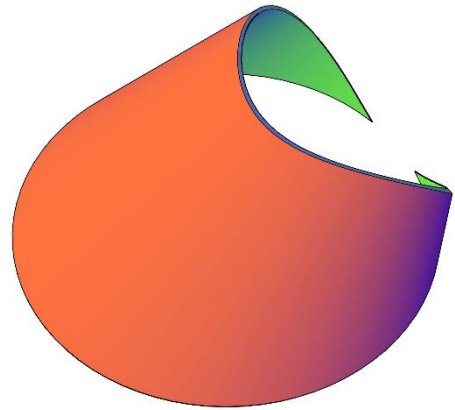

Figure 4a

(Total: 13 marks)

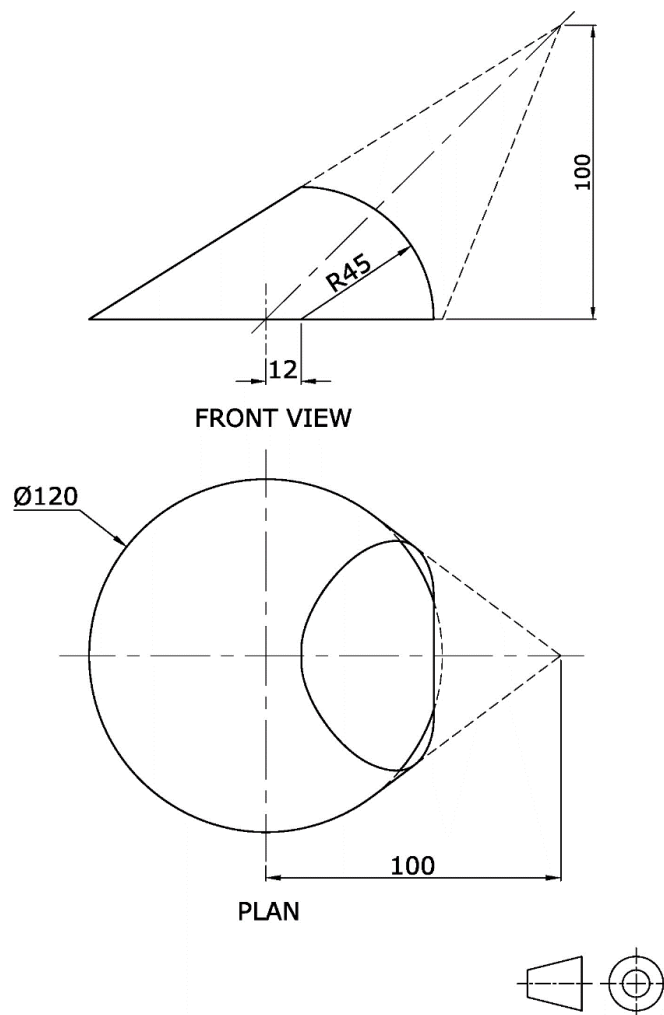

Figure 4b

Please turn the page.

Question 5

A pictorial view of two intersecting prisms is shown in Figure 5a. An elevation of a square prism resting on its base and a triangular prism inclined at 15° to the horizontal plane is shown in Figure 5b. The lines of intersection have been omitted. The true shape of the triangular prism is shown on the auxiliary view. To a scale of 1:1:

- a) copy the given views; (4)
- b) construct the lines of intersection on the front elevation. Indicate how the points of intersection are obtained, showing clearly the visible and hidden lines. Projection lines are to be left on the drawing showing the procedure used. (9)

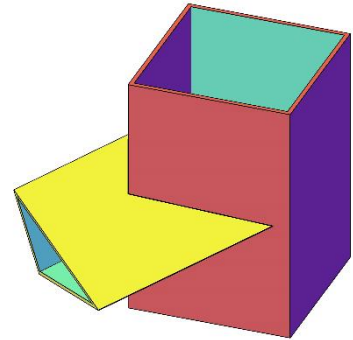

Figure 5a
(Total: 13 marks)

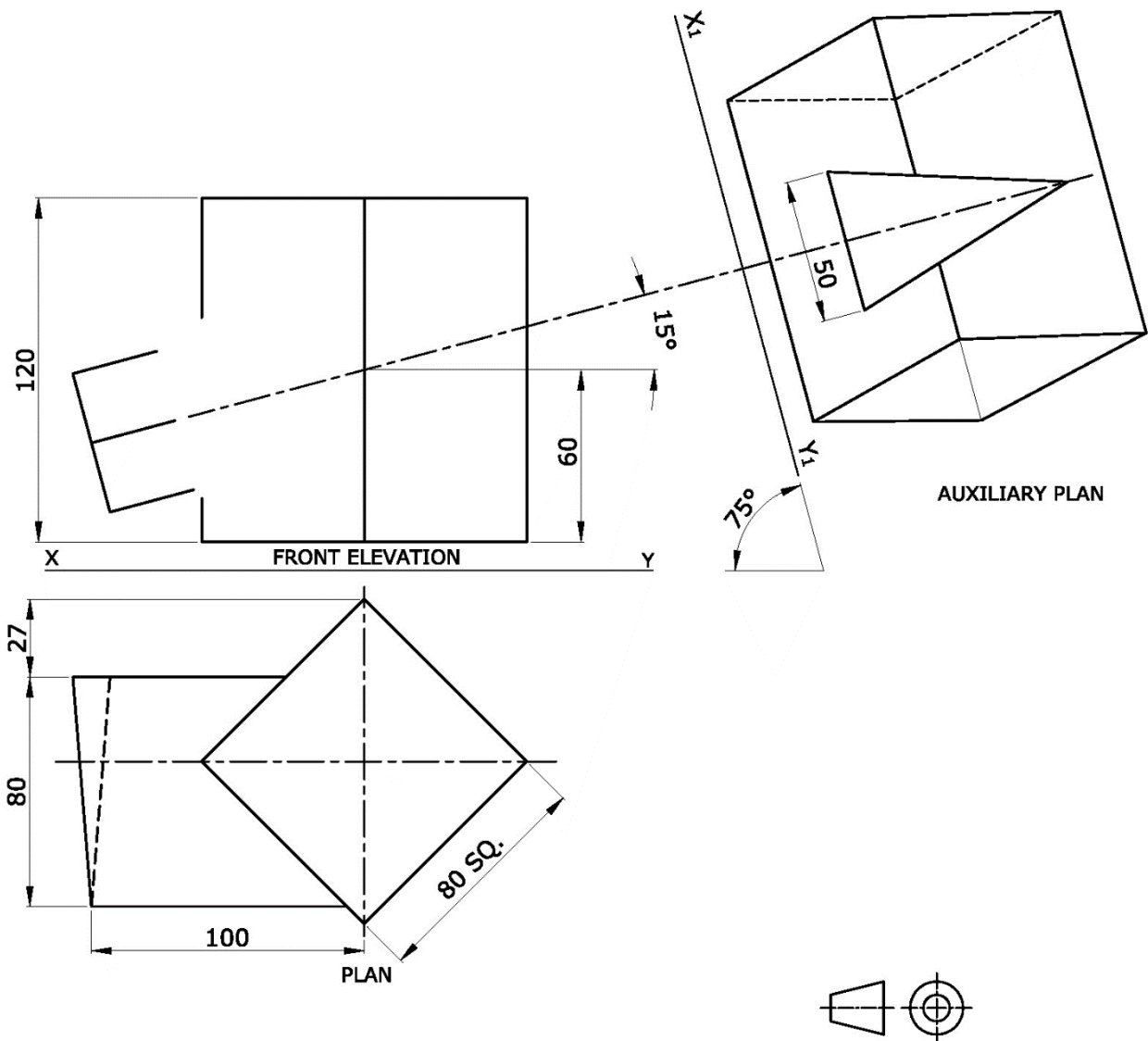

Figure 5b

Question 6

A right-hand helical compression spring is made from a 27 mm square steel is shown in Figure 6a. The outer diameter is 180 mm. A simplified diagram of the square helical spring is shown in Figure 6b. Construct the helical spring including all visible helices for three complete turns of the spring. The pitch is 108 mm. Show the construction of the helix on the first pitch only.

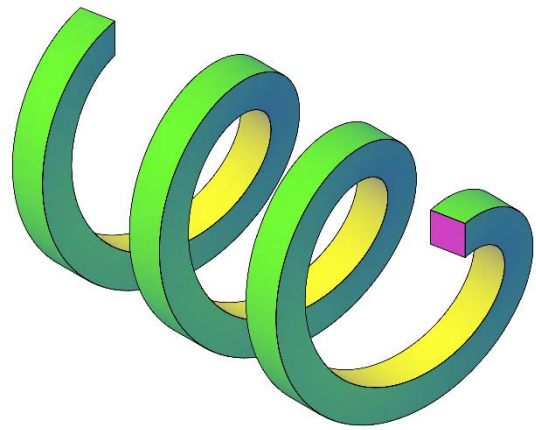

Figure 6a

(Total: 13 marks)

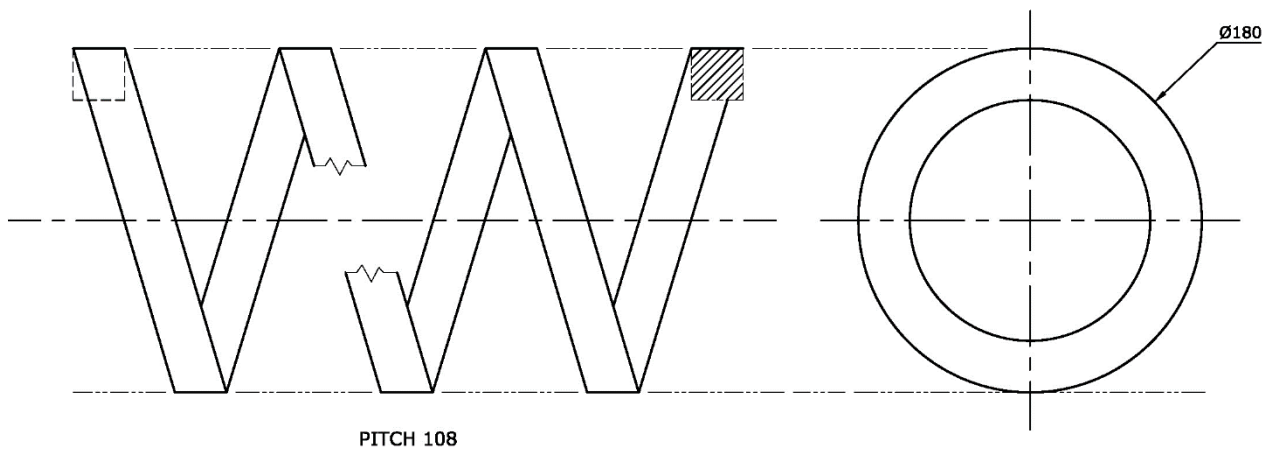

Figure 6b

Please turn the page.

SECTION B

Attempt only **ONE** question from this section.

Question 7

A Balance Lever Assembly is illustrated in Figure 7a, with the various attachments pulled apart. Detail dimensioned drawings of the balance lever and the items which are to be assembled to the lever, are shown in Figure 7b on the attached A3 papers. The parts to be fitted to the lever are assembled as follows.

- the M20 stud (Item 2) is installed with the short thread in the M20 internal thread of the lever (item 1), with the line marked 'P' on the face marked 'Q'.
- an M20 hexagonal nut, (Item 3), is screwed on the M20 stud, the chamfered face of the nut 60 mm from the face marked 'Q'.
- the weight, (Item 4), is screwed onto the M20 threaded portion of the stud, until the face of the 80 mm diameter weight rests against the hexagonal nut.
- another M20 hexagonal nut (Item 5) retains (secures) the weight on the stud.

Draw, to a scale of 1:1, with the parts assembled to the lever:

a) a sectional elevation on the section line X - X; (16)

b) a half sectional end elevation on the section line Y - Y. (8)

Do **not** show hidden details.

(Total: 24 marks)

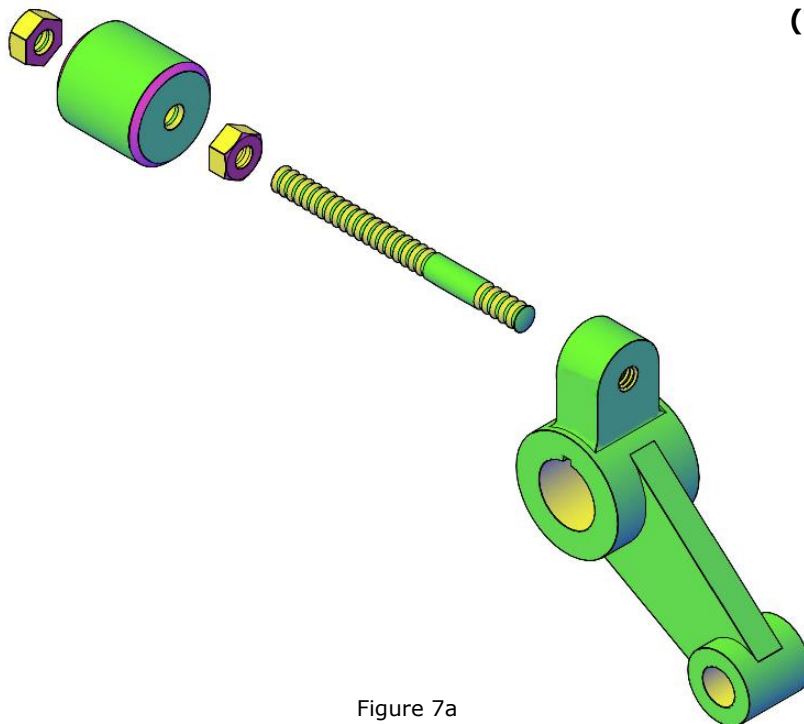

Figure 7a

Question 8

Valves are installed for the purpose of controlling the flow of a fluid in a pipe. An illustration of a valve assembly with the parts pulled apart is shown in Figure 8a. The assembly comprises a valve body, a pin and a handle.

Orthographic drawings of each item that is required for the assembled valve unit are shown on the attached A3 papers, Figure 8b.

The following steps explain how the unit is assembled:

- The valve handle (Item 1) consists of a 200 mm x 24 mm diameter rod with chamfered ends inserted centrally in the 64 mm diameter x 48 mm top portion of the handle.
- A 64 mm x 8 mm diameter pin (Item 2) secures the rod in place. The 8 mm pin is pressed in the 8 mm diameter hole in the centre of the 64 mm diameter portion, through the 8 mm diameter hole.
- The M60 x 60 mm threaded portion of the valve handle (Item 1) is screwed (mounted) into the M60 threaded internal thread of the valve body, (Item 3).
- When the handle is screwed down, the 40 mm diameter end portion of the tapered face seats on the 45° chamfer of the body resting against the tapered 32 mm diameter of the valve body, shutting off the supply of the fluid.

Draw, full size:

- a) an outside front view of the assembled valve handle, pin and valve body. The valve handle is to be shown screwed with the point marked P in line with the 80 mm diameter face marked A of the valve body; (8)
- b) sectional view on the section line X-X, of the assembled valve. (16)

Do **not** show hidden detail. Include suitable fillet radii.

(Total: 24 marks)

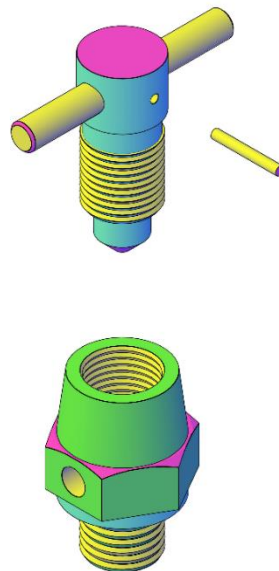

Figure 8a

Please turn the page.

Question 9

An orthographic projection of component for a ratchet assembly is shown in Figure 9. A wrench ratchet is a useful tool for tightening and unscrewing bolts and nuts. It replaces the spanners for it is convenient and saves time, because the bolt or nut may be dismantled without removing the tool from its place.

The two orthographic views of the ratchet show the necessary detail dimensions drawings of the ratchet, which is to be assembled to a wrench ratchet.

Produce, to a scale of 1:1, an isometric projection of the ratchet;
 Present the isometric projection as seen in the direction of the arrow S.
 Constructions lines are to be shown light.

Hidden details are **not** required.

(Total: 24 marks)

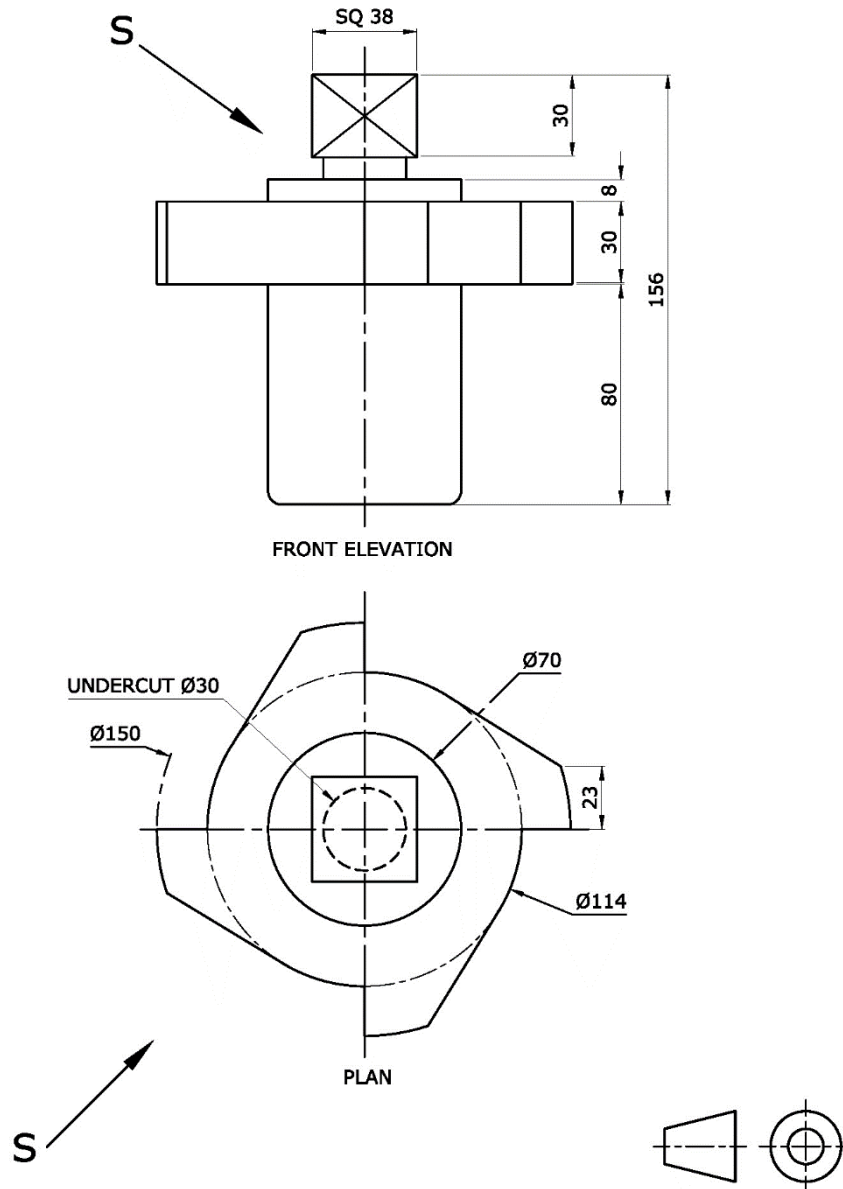

Figure 9

SECTION C

Attempt only **ONE** question from this section.

Question 10

An isometric drawing of a small library is shown in Figure 10a. An orthographic projection of the library is shown in Figure 10b. The library consists of a wooden book display with bottom cupboards and foam square stools.

- a) Use the dimensions given in the orthographic projection to construct an estimated two-point perspective of the library. The viewing direction required is indicated by the arrow in the plan. Use the suggested layout of the two-point perspective shown in the Figure 10c. (21)
- b) Render in colour your drawing to enhance its presentation. (3)

(Total: 24 marks)

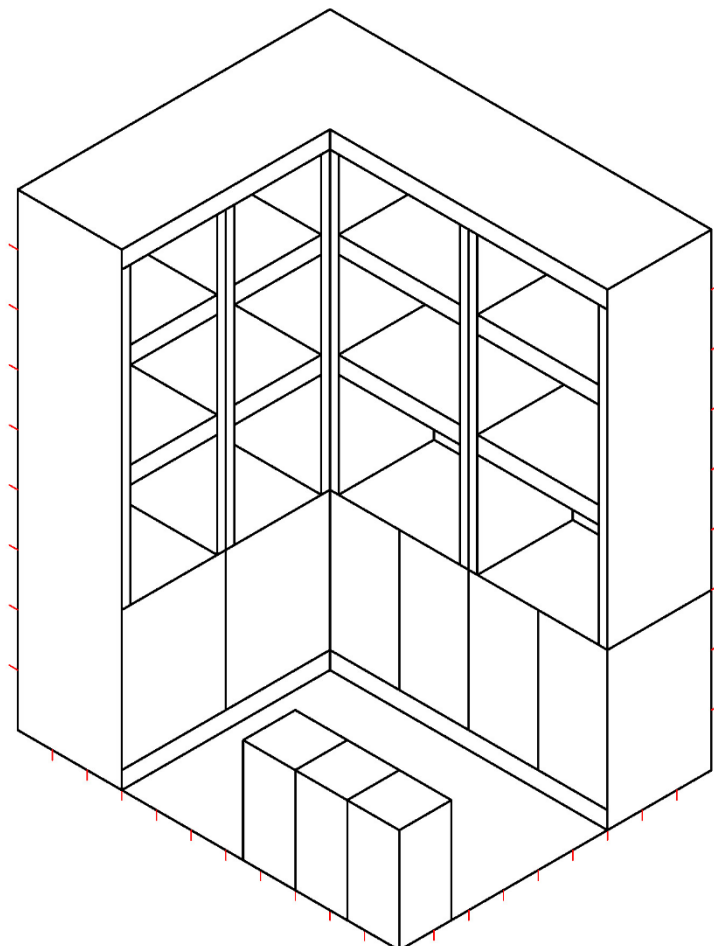

Figure 10a

Please turn the page.

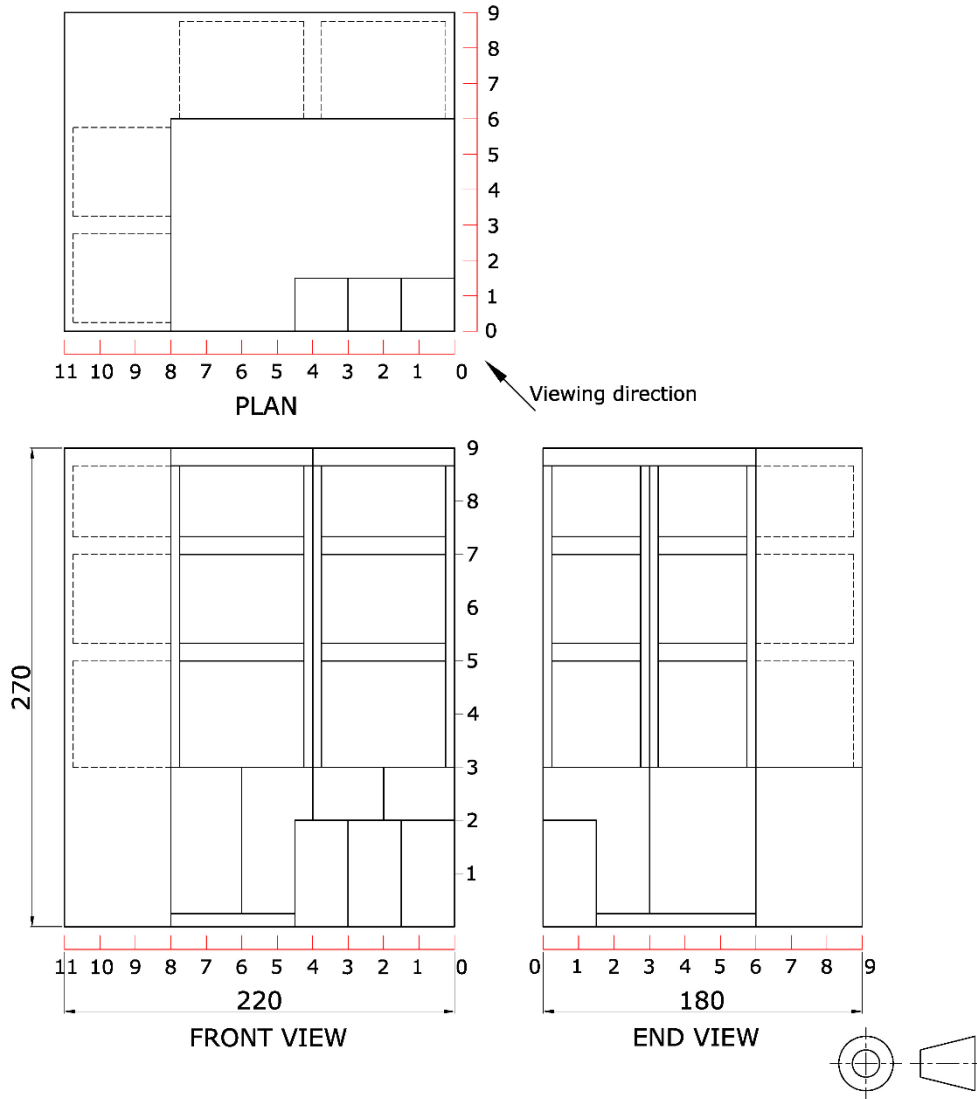

Figure 10b

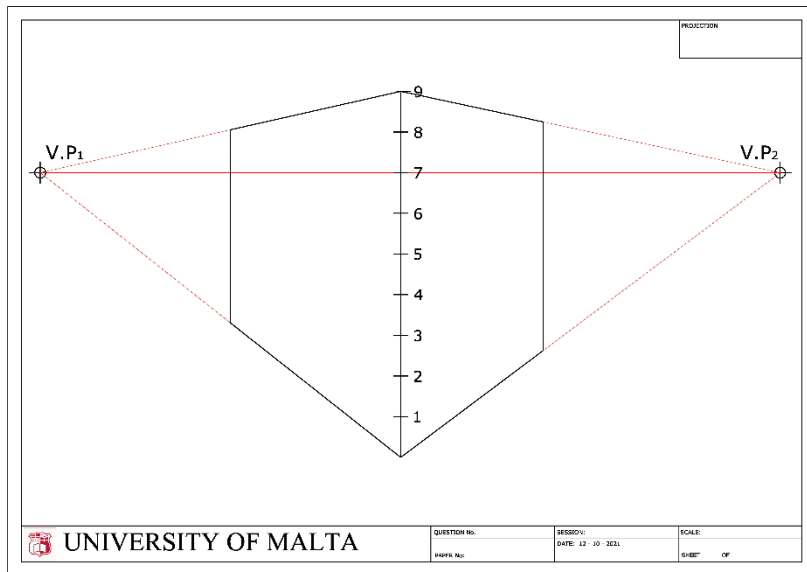

Figure 10c

Question 11

Two isometric views of a room leading to a courtyard is shown in Figure 11a and Figure 11b. An orthographic projection of the room is shown in Figure 11c. The room consists of four concert stairs, a large aluminium door, four wooden shelves and elongated hexagonal windows.

- a) Use the dimensions given in the orthographic projection to construct an estimated one-point perspective of the room. The viewing direction required is indicated by the arrow in the plan. Use the suggested layout for the one-point perspective shown in Figure 11d. (21)
- b) Render in colour your drawing to enhance its presentation. (3)

(Total: 24 marks)

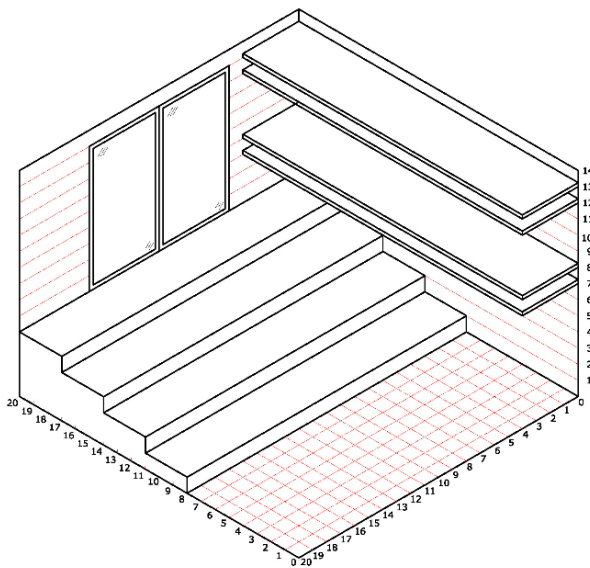

Figure 11a

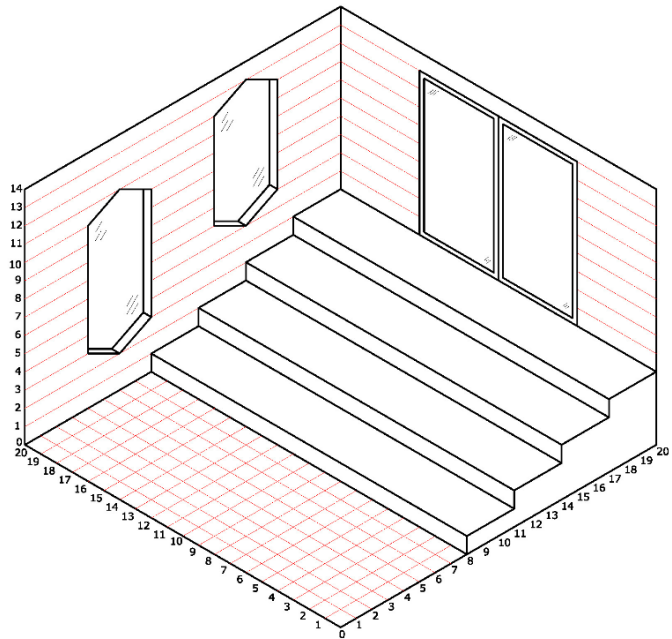

Figure 11b

Please turn the page.

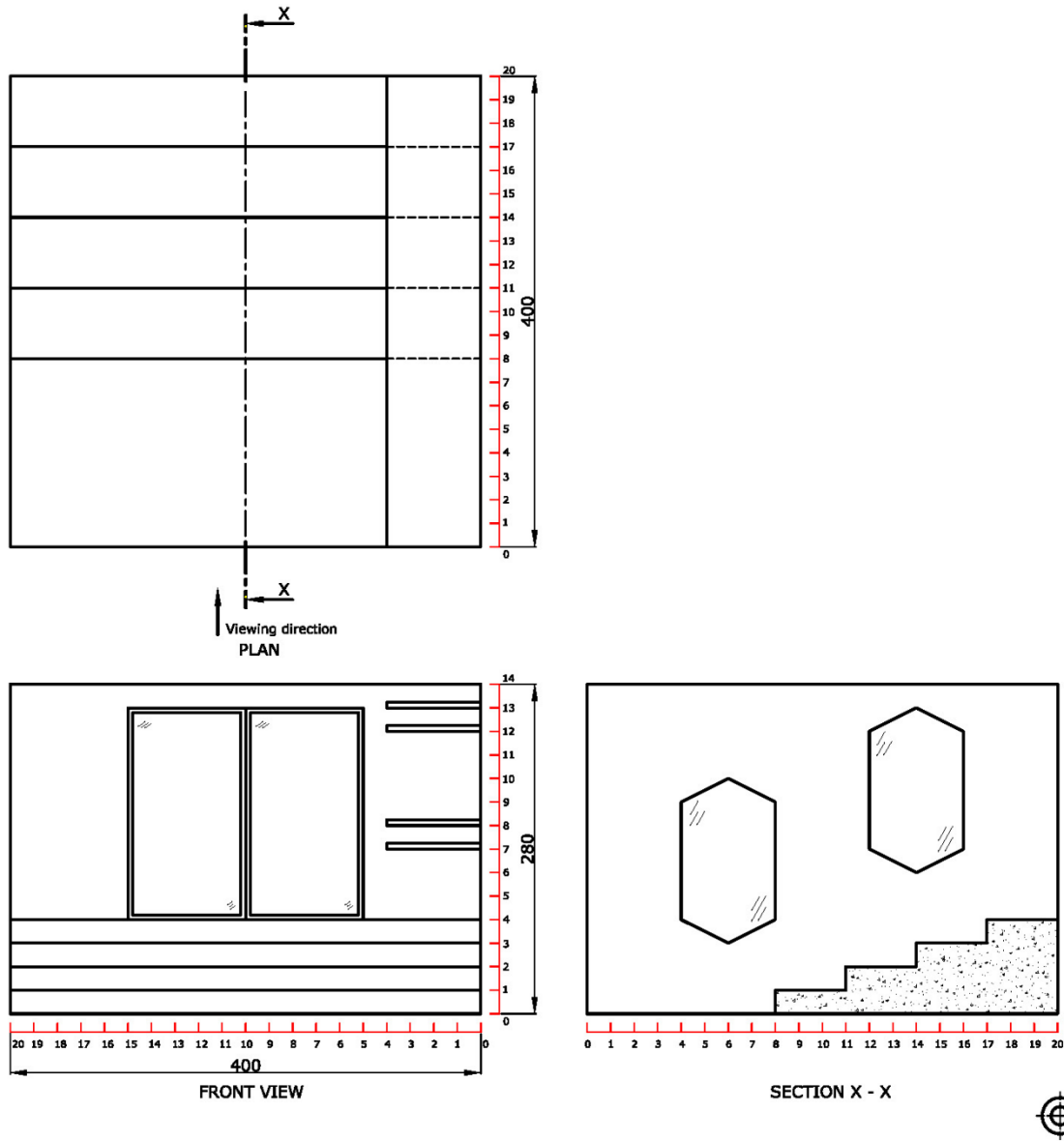

Figure 11c

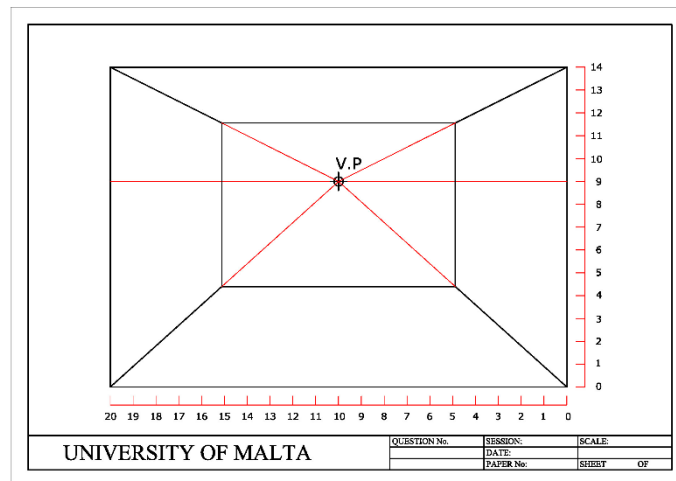

Figure 11d

Question 12

A private company is planning to start operating zero-emission electric buses intended for tourists, operating from Valletta to the Three Cities. The investors are planning to call these buses Merill Buses and they are promising cheap, safe, clean and efficient transport. Their intention is to develop a mobile phone application so that commuters can buy tickets using their mobile phones. In advance of their investment, they analysed some data from the Malta National Statistics Office on Transport Statistics 2020.

Table 12.1: Public transport commuters by routes: August – December 2019
[NSO Transport Statistics reference year 2019]

| Main Route | Public transport commuter | | | | | |
|------------|---------------------------|-----------|---------|----------|----------|---------|
| | August | September | October | November | December | Total |
| Isla | 58,000 | 57,000 | 62,000 | 56,000 | 54,000 | 287,000 |
| Birgu | 40,000 | 43,000 | 48,000 | 41,000 | 40,000 | 212,000 |
| Bormla | 28,000 | 27,000 | 34,000 | 30,000 | 29,000 | 148,000 |

You are required to design a poster. Your presentation must follow the steps given below and organised as suggested in Figure 12.

- Label the poster with the heading "Merill Buses". (2)
- Draw **THREE** graphic app icons to use as a mobile phone application, making it easier for the commuters to find this application on their mobile phone. The icons should be simple and should reflect the company identity. Sketches to develop ideas can be drawn at the side of your A2 sheet. (8)
- Draw a bar chart on your poster showing the number of commuters that have used public transport from August to October, travelling to Isla, Birgu and Bormla. (4)
- Draw a line graph showing the number of commuters that have used public transport from August to December, travelling to Isla, Birgu and Bormla. (4)
- Draw a pie chart showing the total number of commuters that travelled to Isla, Birgu and Bormla. Working to be shown at the side of your A2 sheet. (4)
- Finalise your designed poster. The poster is expected to have a visual impact and carry the intended message clearly. (2)

Notes: All data has been rounded to the nearest thousand.

The Merill is the national bird of Malta, also known as the Blue rock thrush. The Merill is, 21–23 cm in length, with a slim bill and the male has a blue–grey plumage.

Special consideration is to be given to the following:

- the use of colour and shading to render the drawing;
- the use of typography (fonts);
- the formation of an attractive presentation, clearly conveying the information.

(Total: 24 marks)

Please turn the page

| | | | | | | | | | | |
|---|---|--|--------------|----------|-----------|----------------------|--|--------|--|----------|
| <div style="border: 1px solid black; width: 150px; margin: 0 auto; padding: 5px;">a) HEADING</div> | | PROJECTION | | | | | | | | |
| <div style="border: 1px solid black; width: 100%; height: 60px; margin-bottom: 10px;">b) GRAPHIC APP ICON</div> | <div style="border: 1px solid black; width: 100%; height: 60px; margin-bottom: 10px;">b) GRAPHIC APP ICON</div> | <div style="border: 1px solid black; width: 100%; height: 60px; margin-bottom: 10px;">b) GRAPHIC APP ICON</div> | | | | | | | | |
| <div style="border: 1px solid black; width: 100%; height: 100px; margin-bottom: 10px;">c) BAR CHART</div> | | <div style="border: 1px solid black; width: 100%; height: 100px; margin-bottom: 10px;">e) PIE CHART</div> | | | | | | | | |
| <div style="border: 1px solid black; width: 100%; height: 150px;">d) LINE GRAPH</div> | | <div style="border: 1px solid black; width: 100%; height: 150px;">b) SKETCHES TO DEVELOP IDEAS FOR THE GRAPHIC APP ICONS</div> | | | | | | | | |
| <div style="border: 1px solid black; width: 100%; height: 150px;">e) WORKING FOR THE PIE CHART</div> | | | | | | | | | | |
| UNIVERSITY OF MALTA | | <table border="1" style="width: 100%; border-collapse: collapse;"> <tr> <td style="width: 50%; padding: 2px;">QUESTION No.</td> <td style="width: 50%; padding: 2px;">SESSION:</td> </tr> <tr> <td style="padding: 2px;">PAPER No:</td> <td style="padding: 2px;">DATE: 12 - 10 - 2021</td> </tr> <tr> <td style="padding: 2px;"></td> <td style="padding: 2px;">SCALE:</td> </tr> <tr> <td style="padding: 2px;"></td> <td style="padding: 2px;">SHEET OF</td> </tr> </table> | QUESTION No. | SESSION: | PAPER No: | DATE: 12 - 10 - 2021 | | SCALE: | | SHEET OF |
| QUESTION No. | SESSION: | | | | | | | | | |
| PAPER No: | DATE: 12 - 10 - 2021 | | | | | | | | | |
| | SCALE: | | | | | | | | | |
| | SHEET OF | | | | | | | | | |

Figure 12

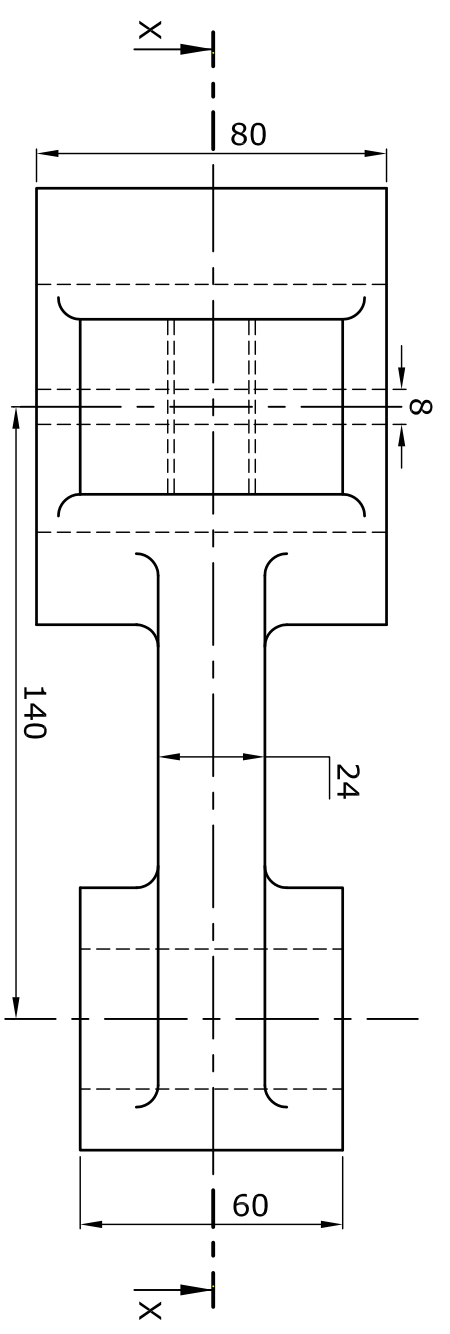

PLAN

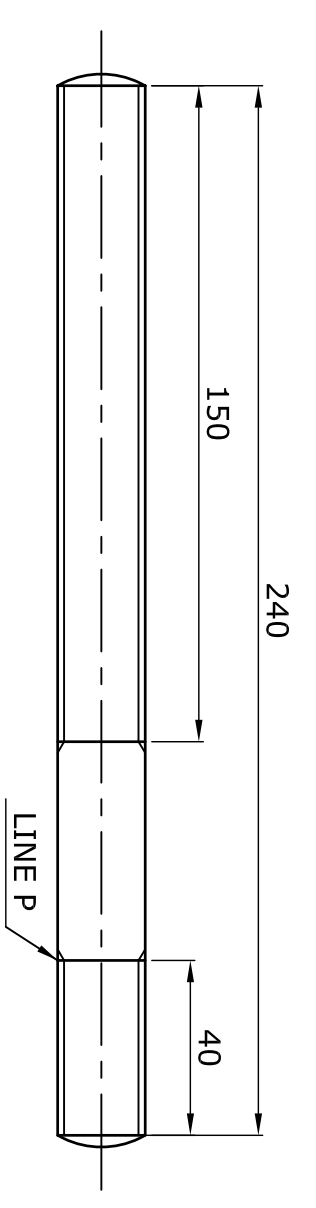

(ITEM 2) M20 STUD

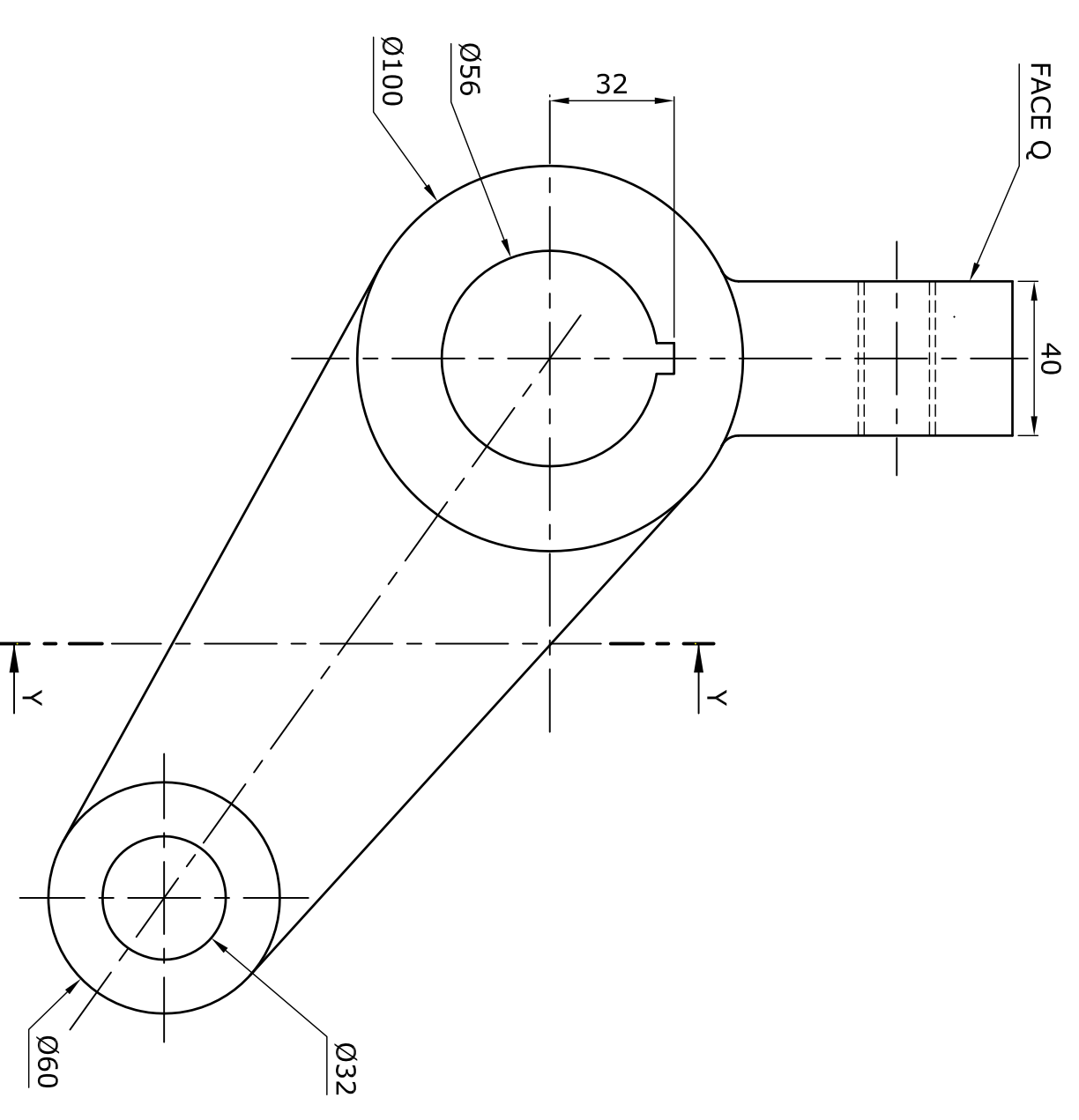

FRONT ELEVATION

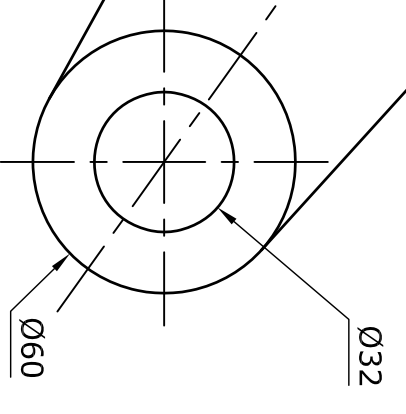

(ITEM 1) LEVER

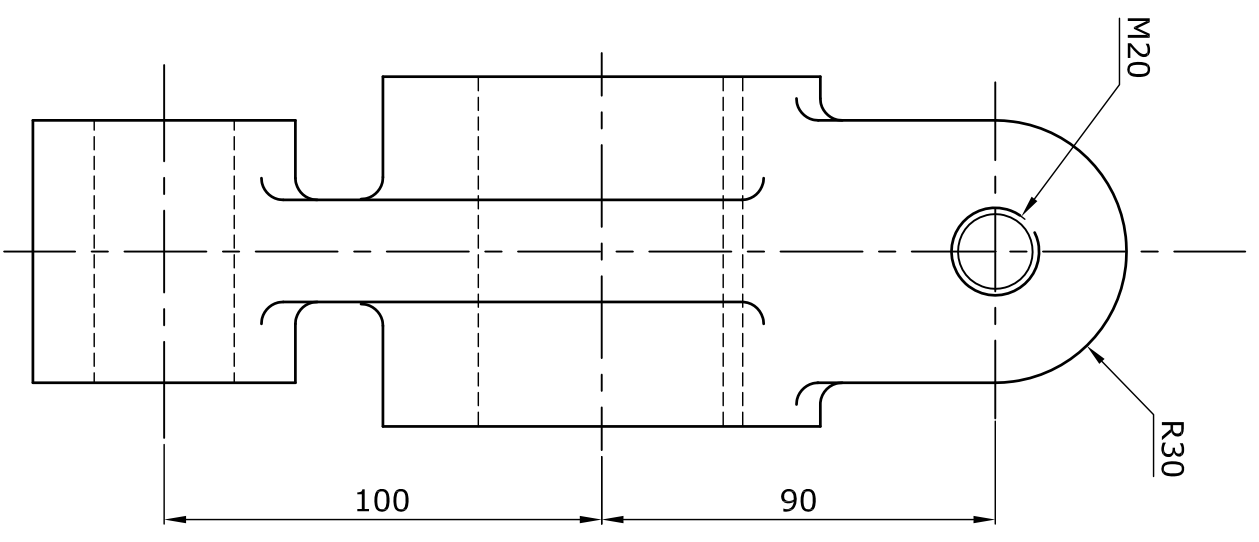

END ELEVATION

BALANCE LEVER

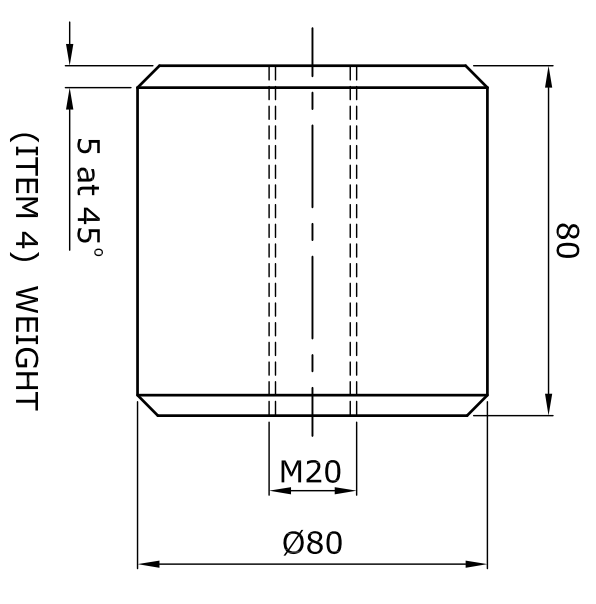

(ITEM 4) WEIGHT

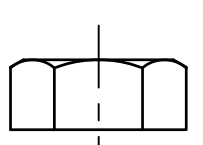

(ITEM 5) M20 NUT

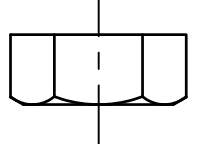

(ITEM 3) M20 NUT

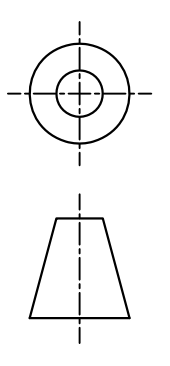

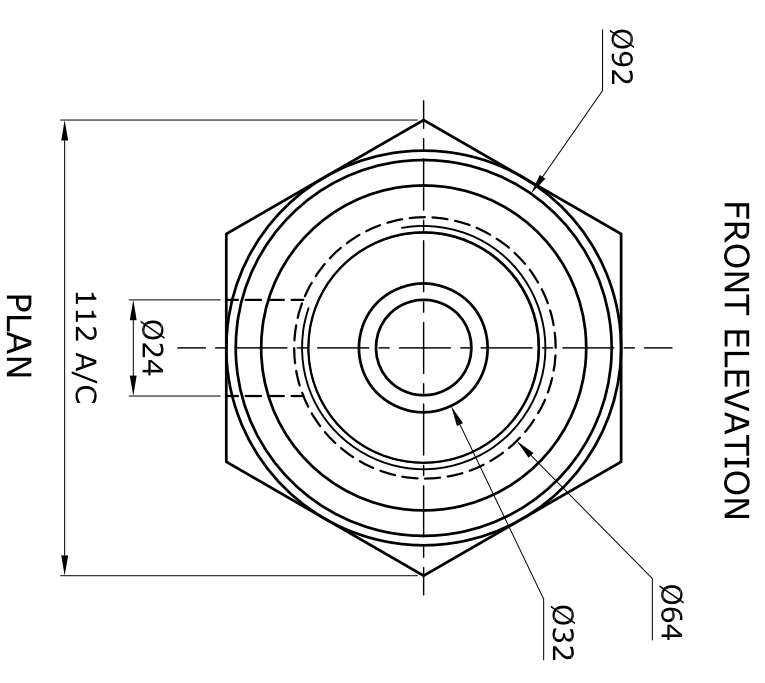
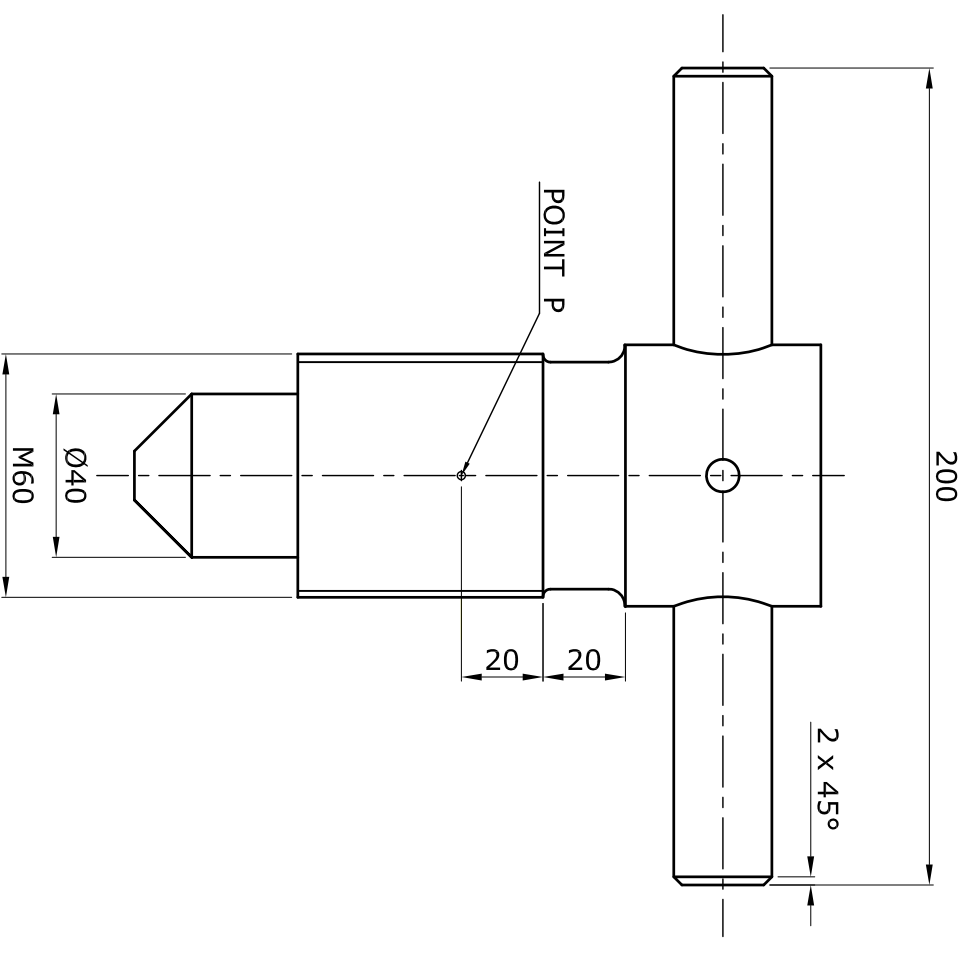
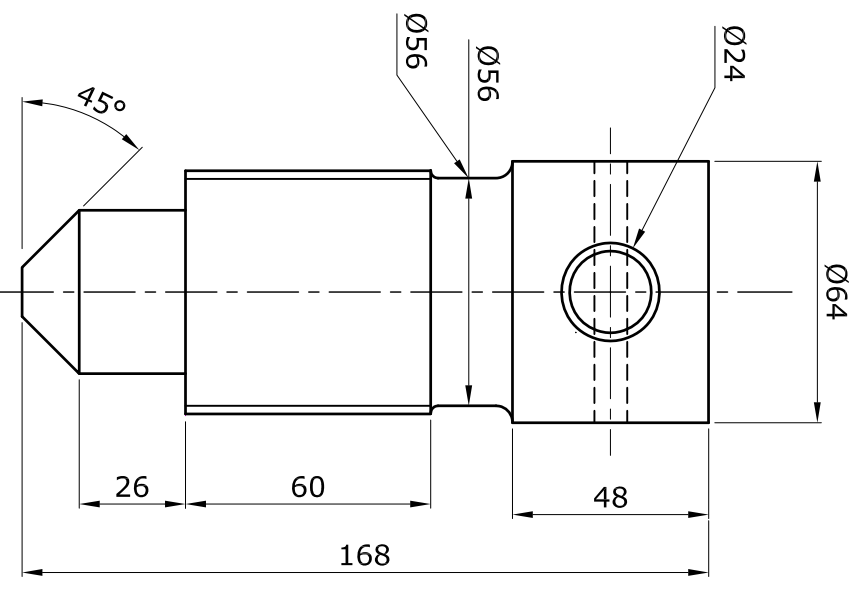
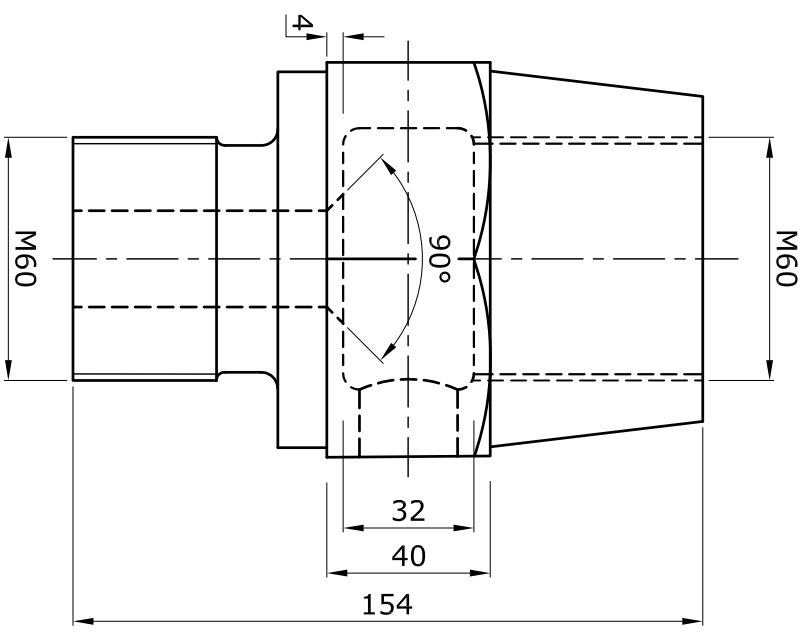
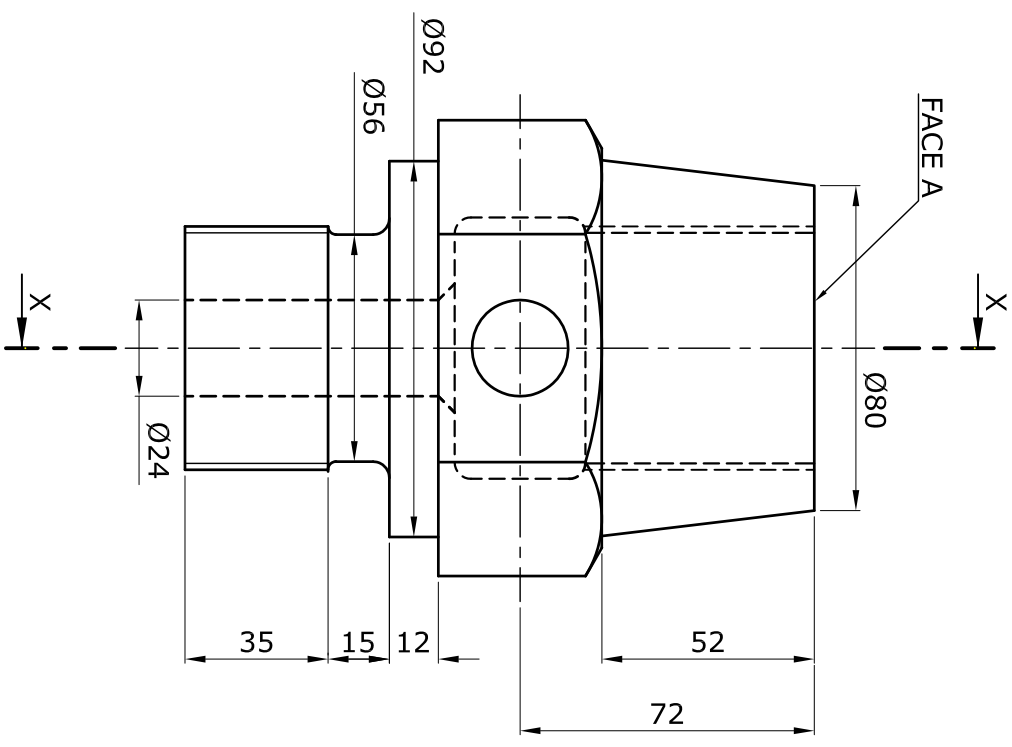

FRONT ELEVATION

END ELEVATION

FRONT ELEVATION

END ELEVATION

VALVE BODY (Item 3)

VALVE HANDLE (Item 1)

