



SUBJECT:	Engineering Drawing and Graphical Communication
DATE:	5 th September 2023
TIME:	9:00 a.m. to 12:05 p.m.

Directions to Candidates

Write your index number where indicated at the top of all Drawing Sheets.

Programmable calculators may **NOT** be used.

Unless otherwise stated:

- B.S. 308 or equivalent (ISO) recommendations should be adopted throughout this paper;
- all dimensions are in millimetres, unless otherwise stated;
- all answers are to be accurately drawn with instruments;
- all construction lines must be left in each solution;
- drawing aids may be used.

Dimensions Number given should be estimated.

Careful layout and presentation are important.

Marks will be awarded for the accuracy, clarity and appropriateness of constructions.

Mark allocations are shown in brackets.

Colour/shading may be used where appropriate.

Section A: Attempt any **FOUR** questions from five.

Section B: Attempt any **ONE** question from two.

Section C: Attempt any **ONE** question from two.

SECTION A

Attempt any **FOUR** questions from this section.

Question 1

The pictorial illustration shown in Figure 1a shows a sheet metal recipient, often referred to as a 'Hopper', designed to fit a horizontal cylindrical pipe. The main part consists of an inverted oblique cone and the end next to the apex manufactured to fit tangentially onto a cylinder.

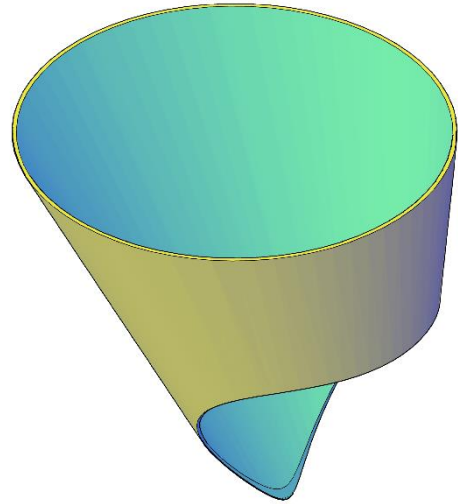
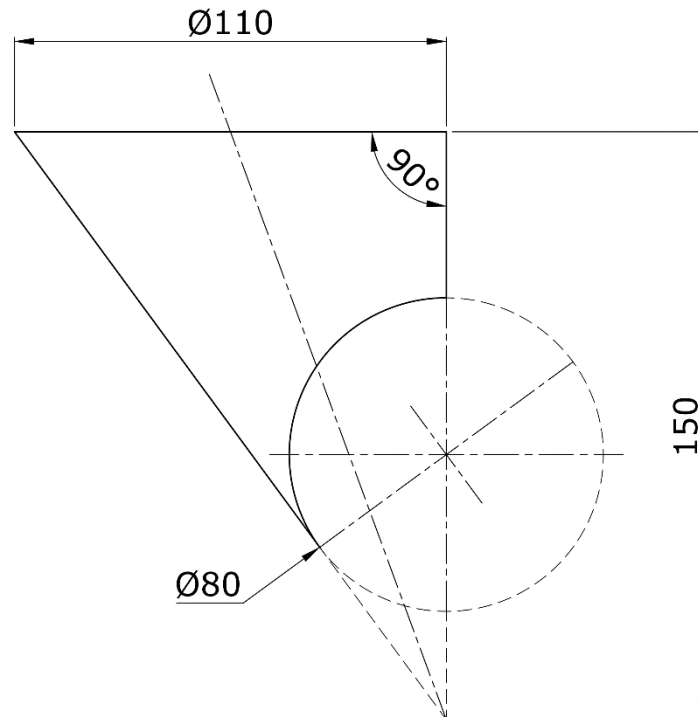

Figure 1a

- a) Copy, full size, Figure 1b showing the truncated inverted oblique cone. The 80 mm diameter cylinder is tangential to the slant height. (2)
- b) Draw a complete plan of the truncated inverted oblique cone. (3)
- c) A pattern of the truncated inverted oblique cone is required. Show clearly how the true lengths of the required generators are obtained. (3)
- d) Construct a half surface development of the truncated inverted oblique cone. (5)

(Total: 13 marks)



FRONT VIEW

Figure 1b

Question 2

A pentagonal prism is machined with a slot to accommodate a rectangular prism as shown in Figure 2a. The rectangular prism is fitted to the pentagonal prism inclined at an angle as shown in the end view of Figure 2b.

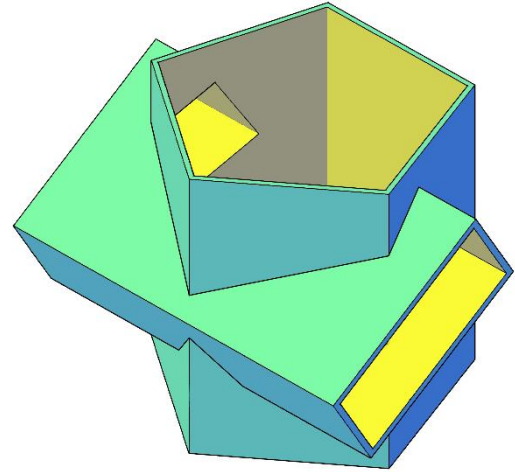

Figure 2a

- a) Copy, full size, the end view and the plan. (3)
- b) Construct the missing visible intersecting lines by bold lines to present a complete front view. (4)
- c) In the front view include the hidden details, represented by dashed lines. (5)

Projection lines showing how the intersecting lines are traced, are to be left on the drawing and represented by light sharp lines. (1)

(Total: 13 marks)

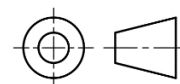
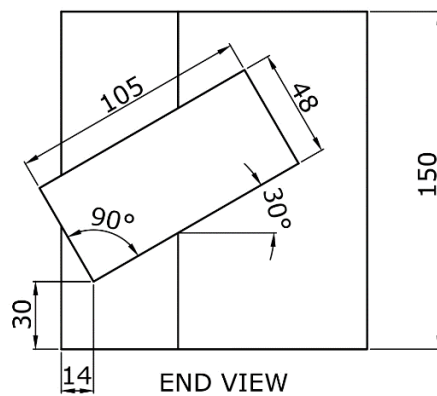
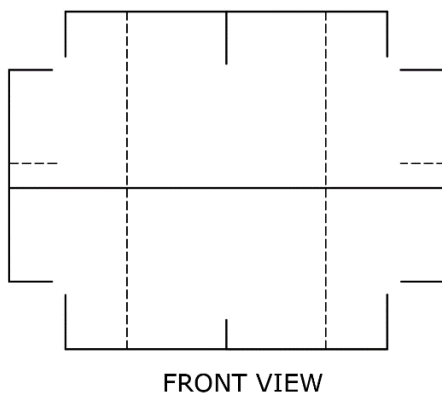
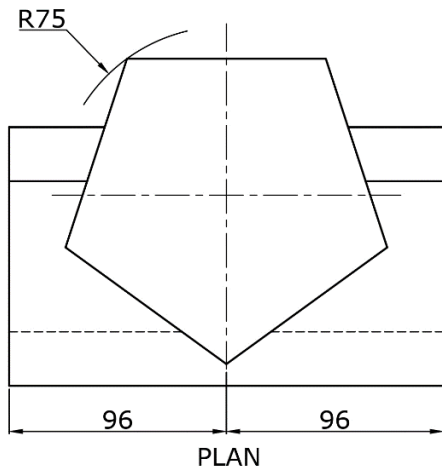

Figure 2b

Please turn the page.

Question 3

A right cone has its 120 mm diameter base, resting on the horizontal plane. A 180 mm diameter hemi-sphere is also resting on the same horizontal plane and in mutual contact with the slant height of the cone, as shown in Figure 3a.

a) Copy, full size, the front view and plan of the cone and place the hemi-sphere resting on the same horizontal plane in mutual contact with the slant height of the cone as shown in Figure 3b. (2)

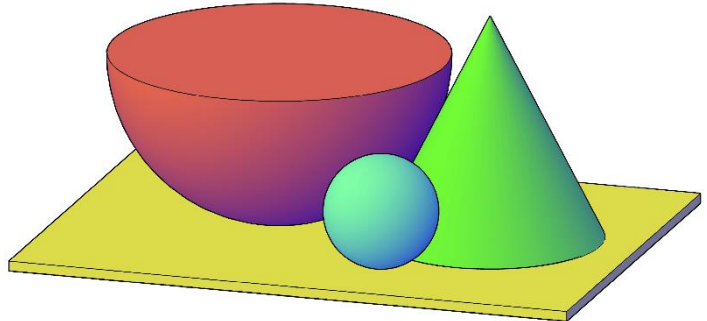

Figure 3a

b) Construct, a front view and the plan of a 60 mm diameter sphere resting on the horizontal plane in mutual contact with the cone and the hemi-sphere. The sphere is to be drawn in front of the cone and the hemi-sphere, clearly visible on the front view. (7)

c) Show all construction neatly, all points of contact and hidden detail. (4)

(Total: 13 marks)

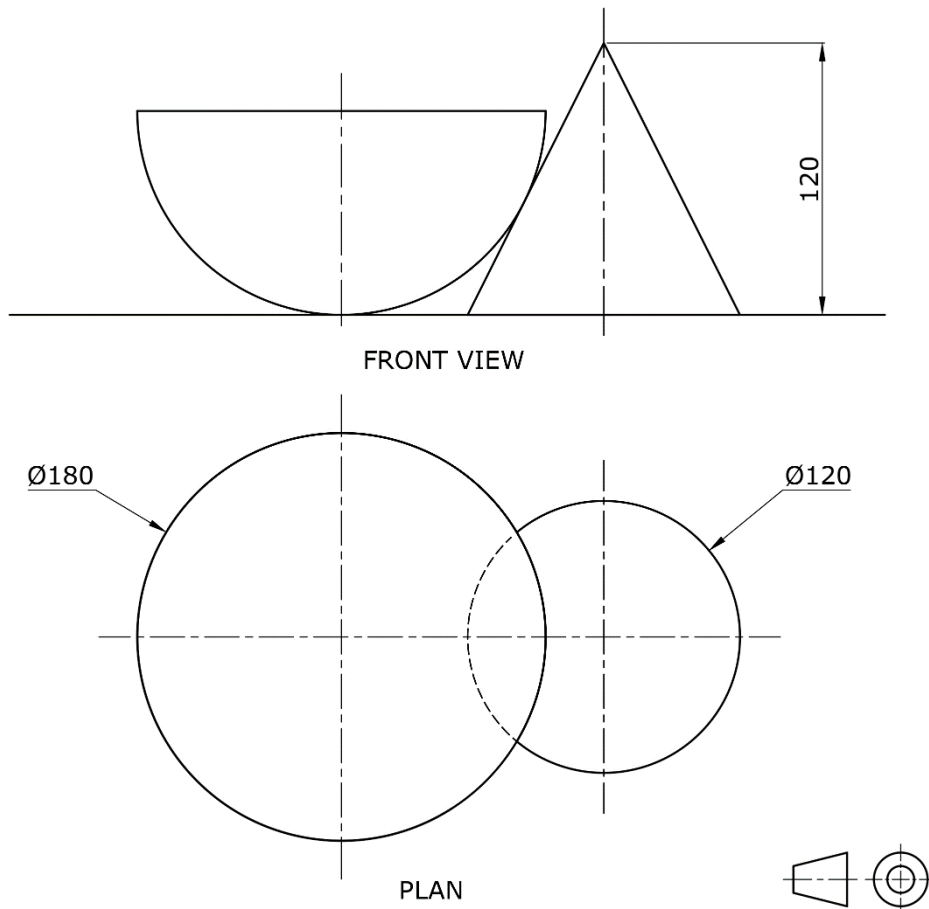

Figure 3b

Question 4

The equilateral triangle standing on the base in the front view represents a cone. Two section planes AB and BC are drawn on the cone as shown in Figure 4b.

- a) Copy, full size, the given front view and the incomplete plan shown in Figure 4b. (2)
- b) Complete the plan. (2)
- c) Construct an auxiliary plan looking in the direction of arrow S. Show hidden detail. (7)
- d) State the name of the conic section AB and BC. (2)

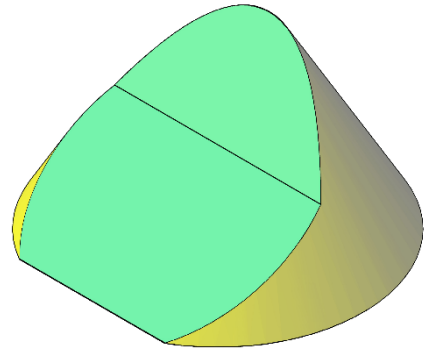

Figure 4a

(Total: 13 marks)

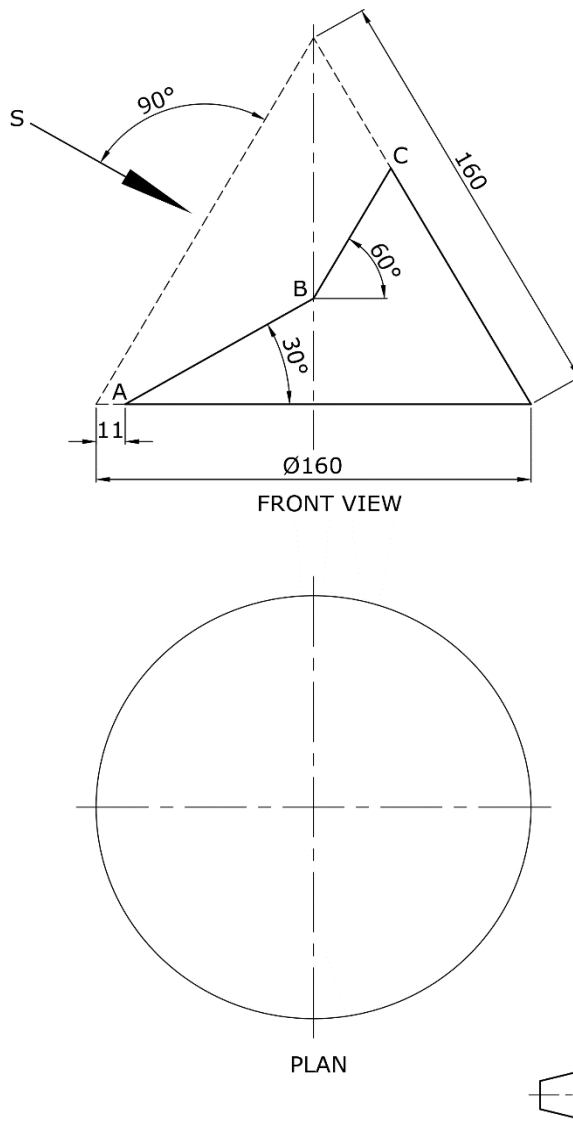

Figure 4b

Please turn the page.

Question 5

A beam loaded with three loads is shown in Figure 5a. The support on the left-hand side is at the end of the beam and the other support on the right is 8 m from the left support.

- a) Copy the space diagram shown in Figure 5b, using the scale indicated and annotate using Bow's notation. (2)
- b) Using a scale of 10 mm representing 20 kN, draw the vector diagram and the polar diagram with the polar distance 100 mm. (3)
- c) Draw the bending moment diagram and determine graphically the values of the left and right supports. State the values. (4)
- d) Construct the shear force diagram. (2)
- e) Indicate the position along the horizontal beam:
 - i. where the bending moment is zero; (1)
 - ii. of the resultant/equilibrant. (1)

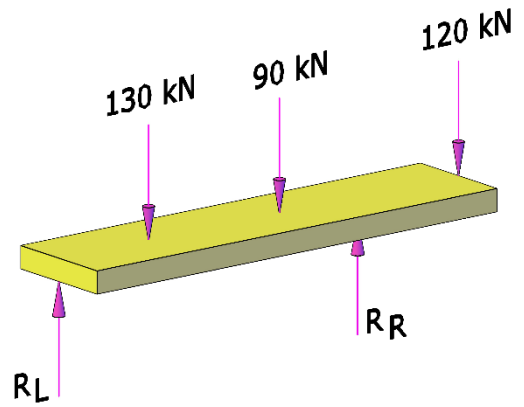

Figure 5a

(Total: 13 marks)

SPACE DIAGRAM: SCALE 20 mm REP 1 m.

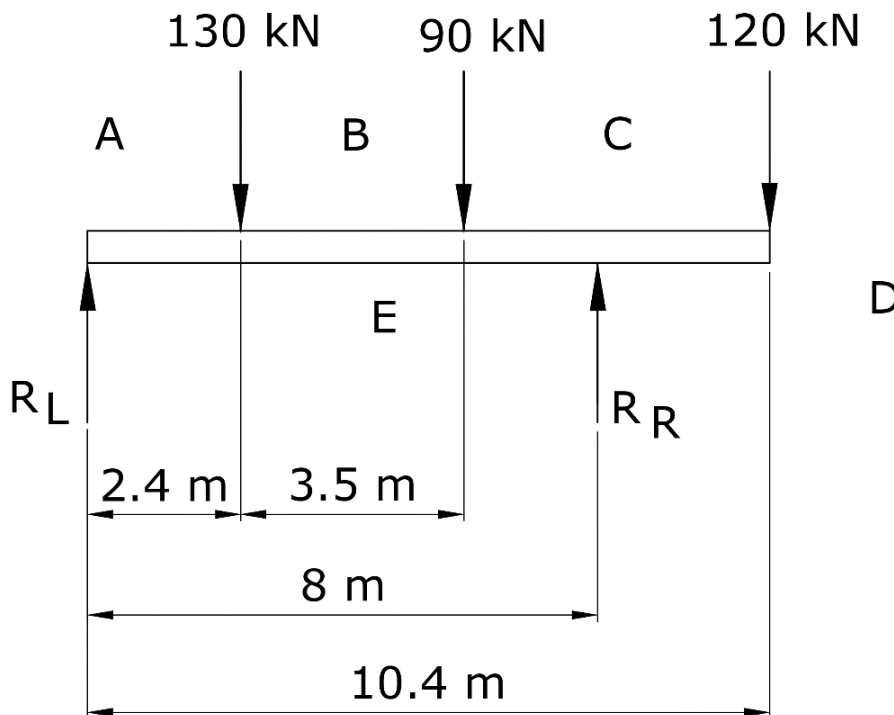

Figure 5b

SECTION B

Attempt only **ONE** question from this section.

Question 6

A three-dimensional exploded view of a shaft support frame is shown in Figure 6a. The parts are to be assembled to form a support for a slow rotating vertical shaft. Orthographic views of each part are shown with the necessary dimensions on the given A3 paper in Figure 6b.

The parts are to be assembled as follows.

- The bronze bush (Item 2) is inserted into the 75 x 60 mm diameter bore of the cast iron frame (Item 1) and rests on the 90 mm horizontal surface of the frame. The bearing (Item 3) is inserted into the inner 40 mm diameter of the bush, with the 40 mm diameter flat face resting on the hollow 60 mm diameter bottom of the frame.
- Four hexagonal headed M10 diameter bolts and nuts secure the shaft support assembly complete with the bush and bearing, from its two 80 x 120 x 15 mm base flanges, to the work top base (Item 4).
- The 40 mm diameter vertical shaft (Item 5) is inserted into the 40 mm diameter bronze bush with the convex end of the shaft resting on the spherical shaped surface of the bearing.

Draw, full size, the following views of the assembled shaft support:

- a) a half sectional view for the section X – X. (14)
Show the right hand side as an outside view.
- b) **ONE** hexagonal bolt and nut securing the frame to the work top base plate, on the hole marked H. (7)
- c) an outside view of the end elevation. (3)

(Total: 24 marks)

Please turn the page.

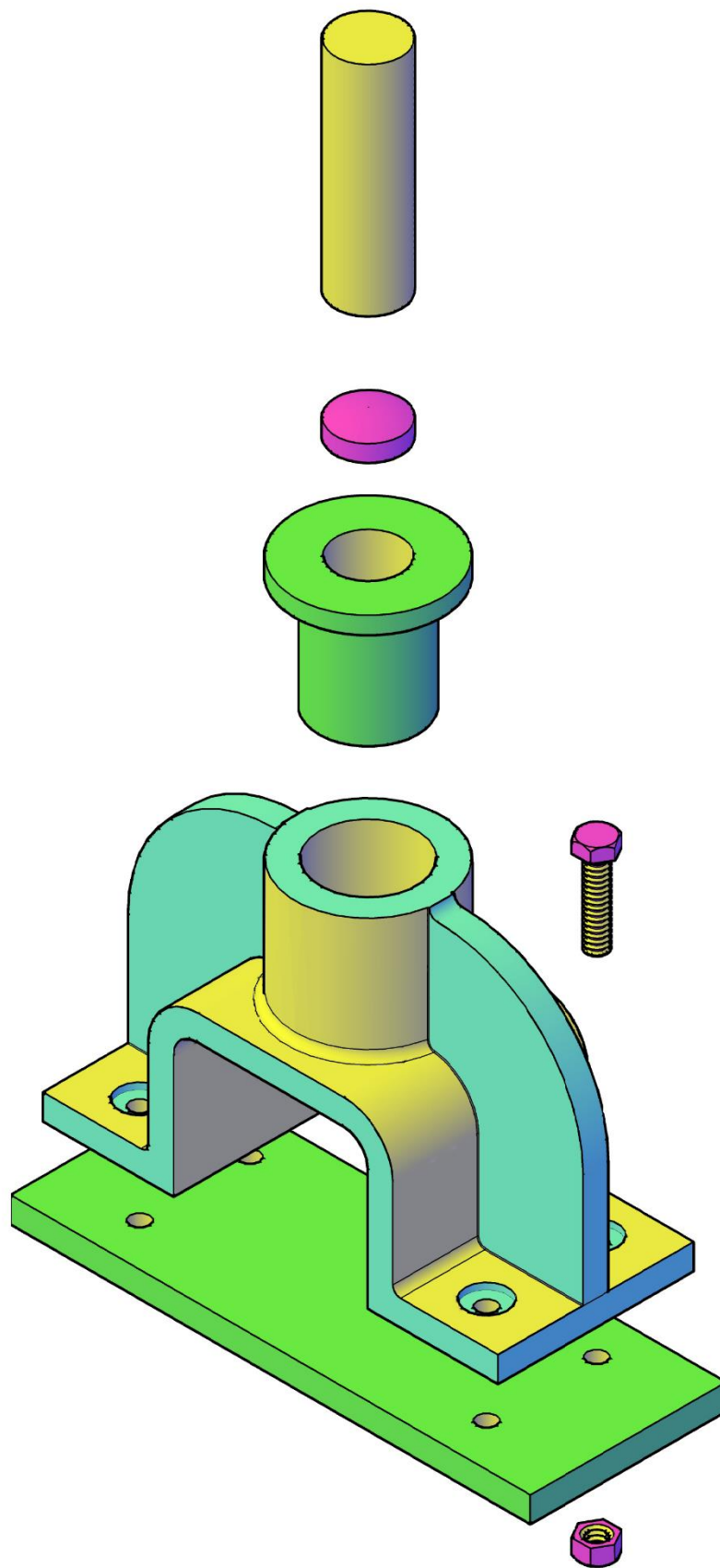

Figure 6a

Question 7

- i. A view of the end of an M20 stud assembled on a machine part is shown in Figure 7a on the attached A3 paper. A positive lock is required to withstand vibration and the lock nut preferred is the castle nut, sometimes referred to as a slotted nut, and secured by a split pin.

Copy, the given views shown in Figure 7a and complete the two views by including the castle nut securing the nut to the stud. (6)

- ii. Part of a disc crank used for a motor cycle engine, consists of two dropped forged steel discs, keyed to the separate parts of the crank shaft as shown in Figure 7b on the attached A3 paper.

The nut securing both the crank shaft and the crank pin is locked by a special locking plate (not shown in the Figure).

Two incomplete orthographic views of the assembled disc and the crank shaft with the hexagonal nut securing the discs are shown in the Figure 7b.

Copy, the two views of the sub-assembly and include on the diagram a complete suitable appropriate locking plate, to prevent the nut from loosening, securing the nut to the shaft. Include the feature showing how the plate is secured to the component. (6)

- iii. When a shaft is used to transmit torque to another shaft or to a member such as a pulley or a gear, a key is used to prevent relative motion between the shaft and the device to which it is joined.

Figure 7c on the attached A3 paper shows orthographic views of a pulley and shaft, which are to be assembled together.

Detailed drawing of the key is not included. The key must include a head feature used to drive the key easily into the keyway and used to facilitate removal.

The head feature shall allow the removal of the key by driving a tapered wedge between the hub face and the head feature of the key.

Draw a sectional view of the assembly showing an appropriate key in position. (5)

Write down the technical term of the key used. (1)

- iv. A front view and an end view of a pulley and two views of a tapered shaft are shown in Figure 7d on the attached A3 paper.

Copy the given view of the shaft and the tapered end and assemble the hub to the tapered shaft. Draw a suitable key to prevent relative motion between the shaft and the hub. The key must be able to rock in the seating and adjust to the tapered shaft. (5)

State the technical term of this particular key. (1)

N.B. Question 7 solutions are to be drawn on **ONE** A2 paper.

(Total: 24 marks)

Please turn the page.

SECTION C

Attempt only **ONE** question from this section.

Question 8

A new real estate company named Heart Dream Homes (HDH) is planning to start marketing and selling private properties in central Malta. Their aim is to showcase properties in Malta for residential use and negotiate the price on behalf of the seller. Heart Dream Homes mission statement is going to be: 'Clients` needs are the heart of our service'. HDH would like to gain the trust of its clients to find their right home. In advance of the investment, HDH analysed some data from the Malta National Statistics Office on final deeds of sale involving buyers in the first three months of 2021, 2022 and 2023. HDH is also analysing data on some central locations in Malta for the first three months of 2023.

Table 8.1: Number of final deeds of sales involving buyers (households) by period of registration.
[NSO Transport Statistics reference March 2023]

Period	Sales involving individual buyers (households)		
	2021	2022	2023
January	930	1,060	1,010
February	900	990	870
March	1,190	1,100	960
Total	3,020	3,150	2,840

Table 8.2: Number of final deeds of sales by period of registration and locality.
[NSO Transport Statistics reference March 2023]

Locality	Final deeds of sales for 2023		
	January	February	March
Birkirkara	42	29	40
Mosta	37	25	55
Naxxar	18	17	28

You are required to design a poster. Your presentation must follow the steps given below and organised as suggested in Figure 8.

- Label the poster with the heading "Heart Dream Homes". (2)
- Draw **THREE** graphic app icons to use as a mobile phone application, subsequently the company may choose the most suitable icon. This app icon should make it easier for customers to find this application on their mobile phone and use the company services. The icons should be simple and should reflect the company identity. Sketches to develop ideas can be drawn at the side of your A2 sheet. (8)
- Draw a bar chart on your poster showing the sales involving individual buyers (households) for the period of January, February and March for 2021, 2022 and 2023. Use Table 8.1. (4)
- Draw a line graph showing the final deeds of sale for 2023 in January, February and March for Birkirkara, Mosta and Naxxar. Use Table 8.2. (4)
- Draw a pie chart showing the total number of sales involving individual buyers (households) for the period of January, February and March. Use Table 8.1. (4)
- Finalise your designed poster. The poster is expected to have a visual impact and carry the intended message clearly. (2)

Special consideration is to be given to the following:

- i. the use of colour and shading to render the drawing;
- ii. the use of typography (fonts);
- iii. the formation of an attractive presentation, clearly conveying the information.

(Total: 24 marks)

<div style="text-align: center; margin-bottom: 20px;"> <div style="border: 1px solid black; display: inline-block; padding: 2px 10px;">a) HEADING</div> </div> <div style="display: flex; justify-content: space-around; margin-bottom: 20px;"> <div style="border: 1px solid black; width: 150px; height: 100px; display: flex; align-items: center; justify-content: center; font-size: 8px;">b) GRAPHIC APP ICON</div> <div style="border: 1px solid black; width: 150px; height: 100px; display: flex; align-items: center; justify-content: center; font-size: 8px;">b) GRAPHIC APP ICON</div> <div style="border: 1px solid black; width: 150px; height: 100px; display: flex; align-items: center; justify-content: center; font-size: 8px;">b) GRAPHIC APP ICON</div> </div> <div style="border: 1px solid black; width: 200px; height: 150px; display: flex; align-items: center; justify-content: center; margin-bottom: 20px; font-size: 8px;">e) PIE CHART</div> <div style="display: flex; justify-content: space-between;"> <div style="border: 1px solid black; width: 300px; height: 200px; display: flex; align-items: center; justify-content: center; font-size: 8px;">c) BAR CHART</div> <div style="border: 1px solid black; width: 300px; height: 200px; display: flex; align-items: center; justify-content: center; font-size: 8px;">d) LINE GRAPH</div> </div>	<div style="border: 1px solid black; width: 100%; height: 40px; margin-bottom: 10px;">PROJECTION</div> <div style="font-size: 8px; margin-bottom: 10px;">b) SKETCHES TO DEVELOP IDEAS FOR THE GRAPHIC APP ICONS</div> <div style="font-size: 8px;">e) WORKING FOR THE PIE CHART</div>						
UNIVERSITY OF MALTA	<table border="1" style="width: 100%; border-collapse: collapse;"> <tr> <td style="width: 50%;">QUESTION No.</td> <td style="width: 50%;">SESSION:</td> </tr> <tr> <td>PAPER No:</td> <td>DATE: 5 - 9 - 2023</td> </tr> <tr> <td></td> <td>SHEET OF</td> </tr> </table>	QUESTION No.	SESSION:	PAPER No:	DATE: 5 - 9 - 2023		SHEET OF
QUESTION No.	SESSION:						
PAPER No:	DATE: 5 - 9 - 2023						
	SHEET OF						

Figure 8

Please turn the page.

Question 9

An isometric drawing of a storeroom in a chemistry lab is shown in Figure 9a. An orthographic projection of the storeroom is shown in Figure 9b. The room consists of a wooden desk, a wooden cabinet with shelves and drawers and a wooden hanging cupboard.

- a) Use the dimensions given in the orthographic projection to construct an estimated two-point perspective of the storeroom. The viewing direction required is indicated by the arrow in the plan. Use the layout of the two-point perspective shown in Figure 9c. (21)
- b) Render in colour your drawing to enhance its presentation. (3)

(Total: 24 marks)

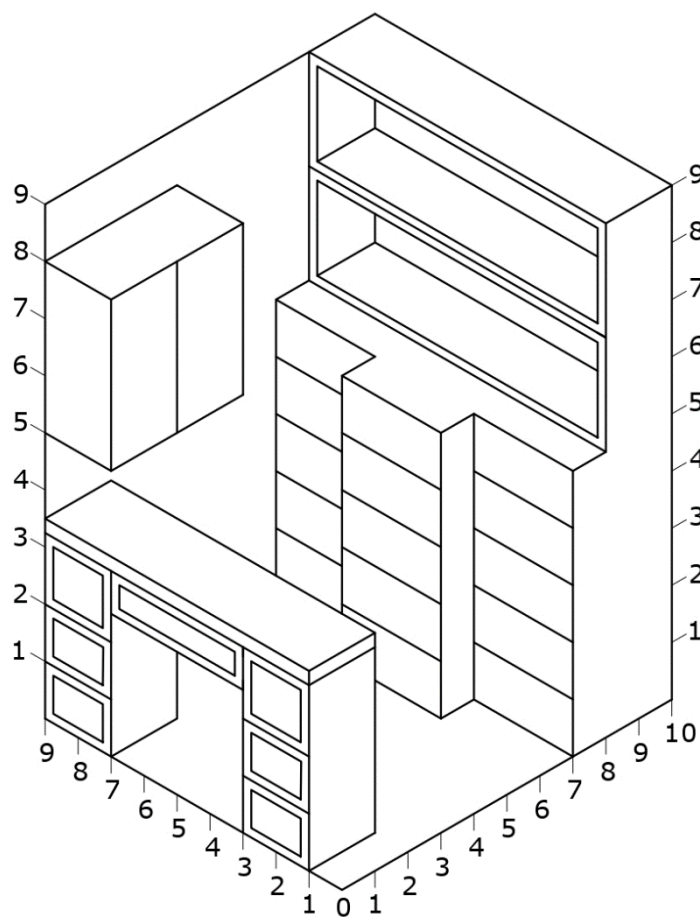

Figure 9a

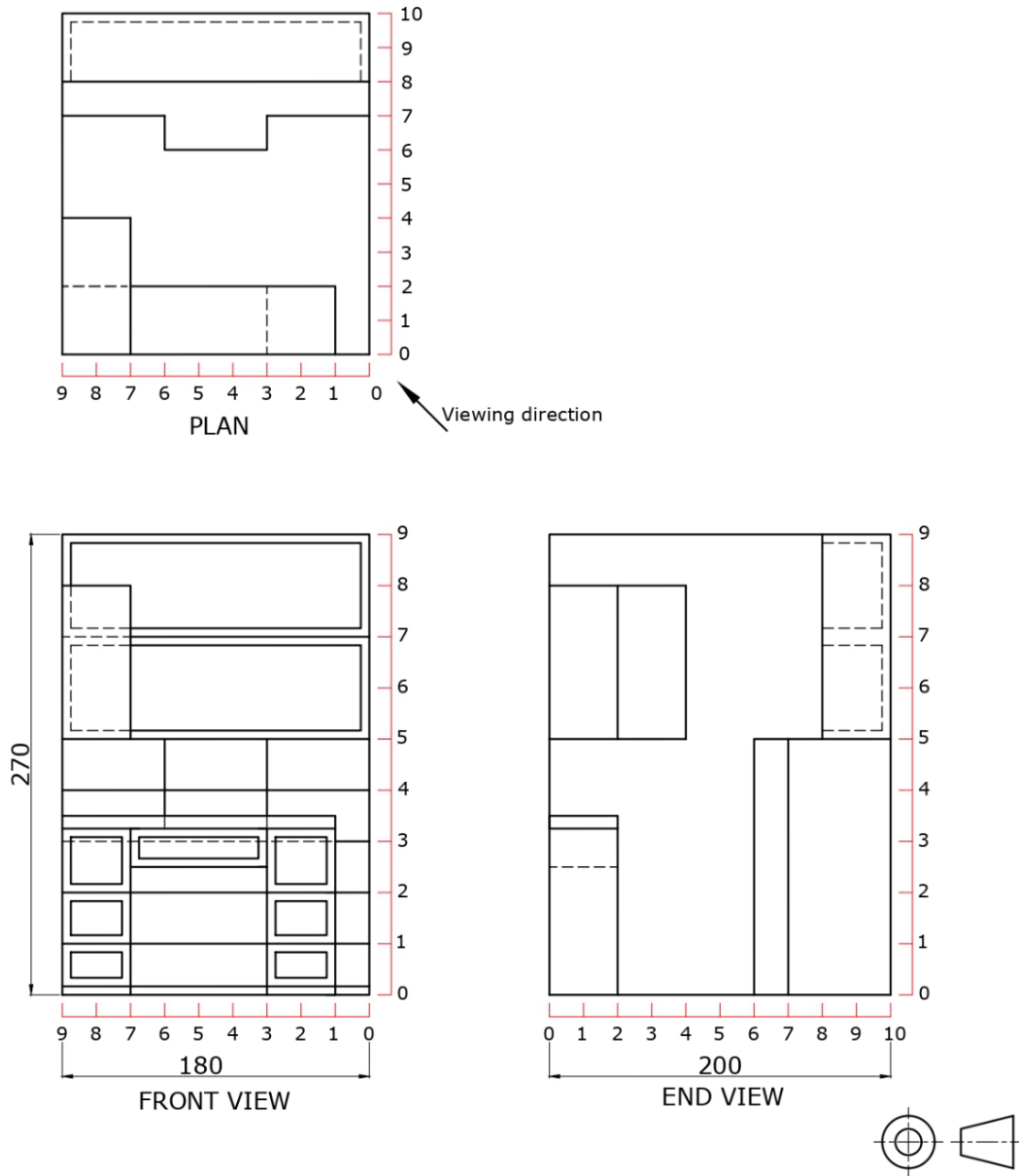

Figure 9b

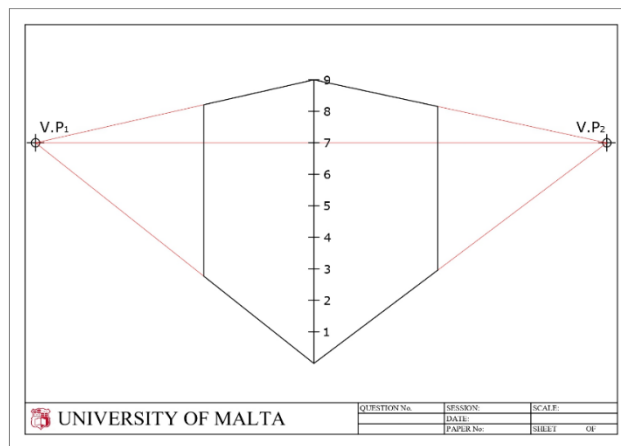
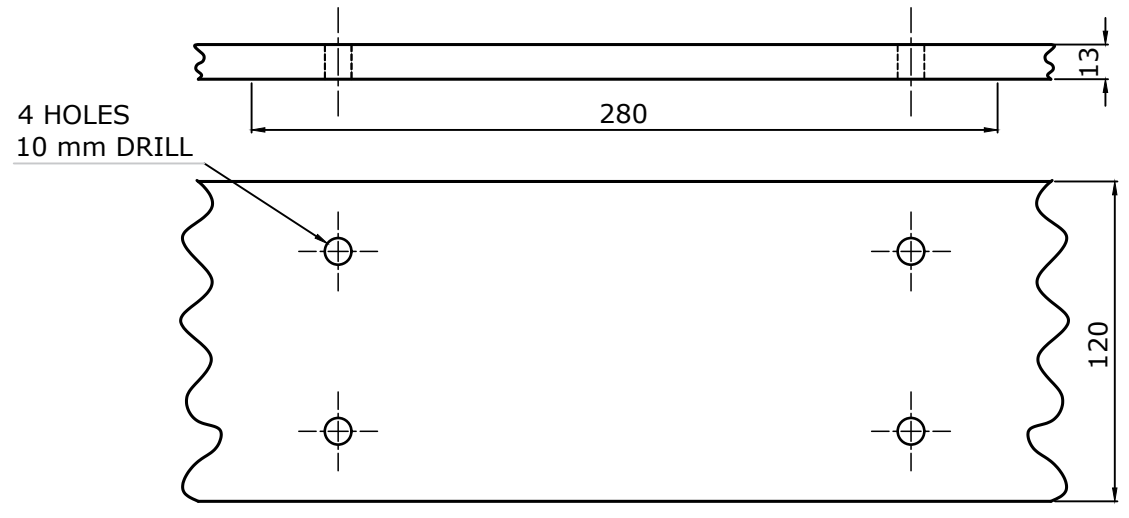
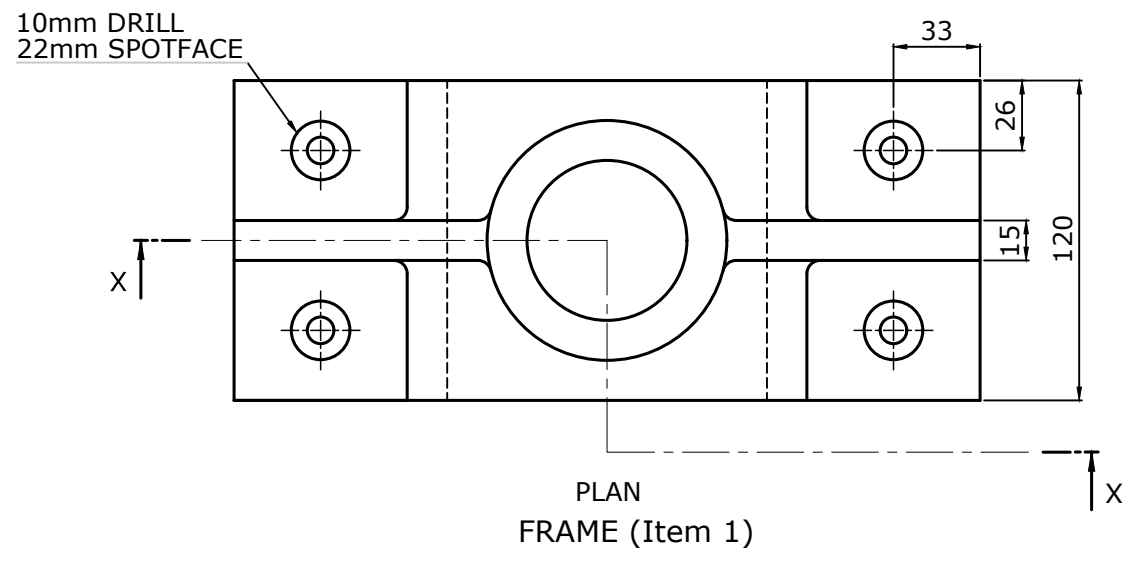
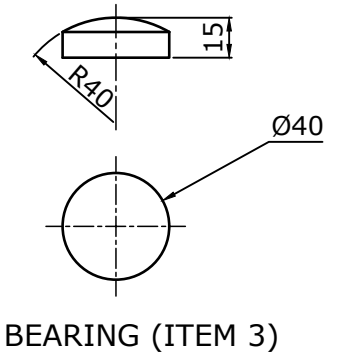
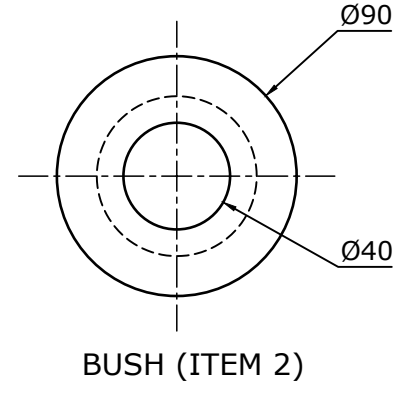
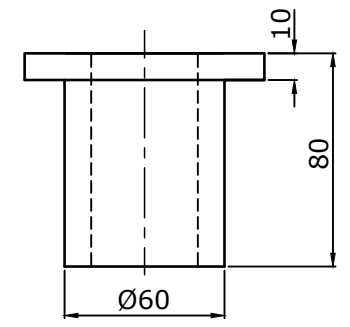
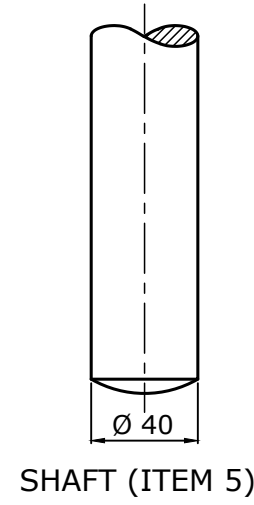
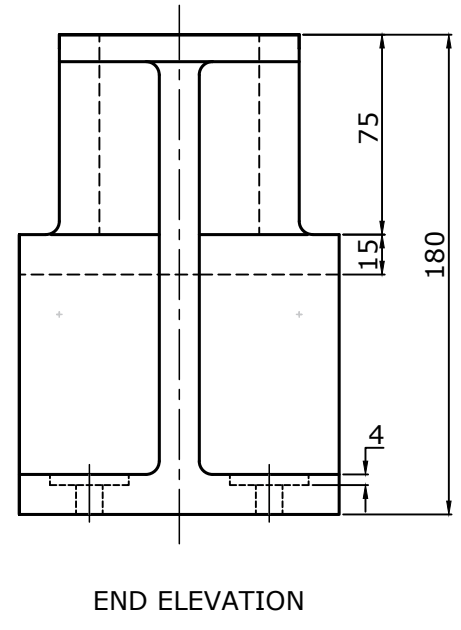
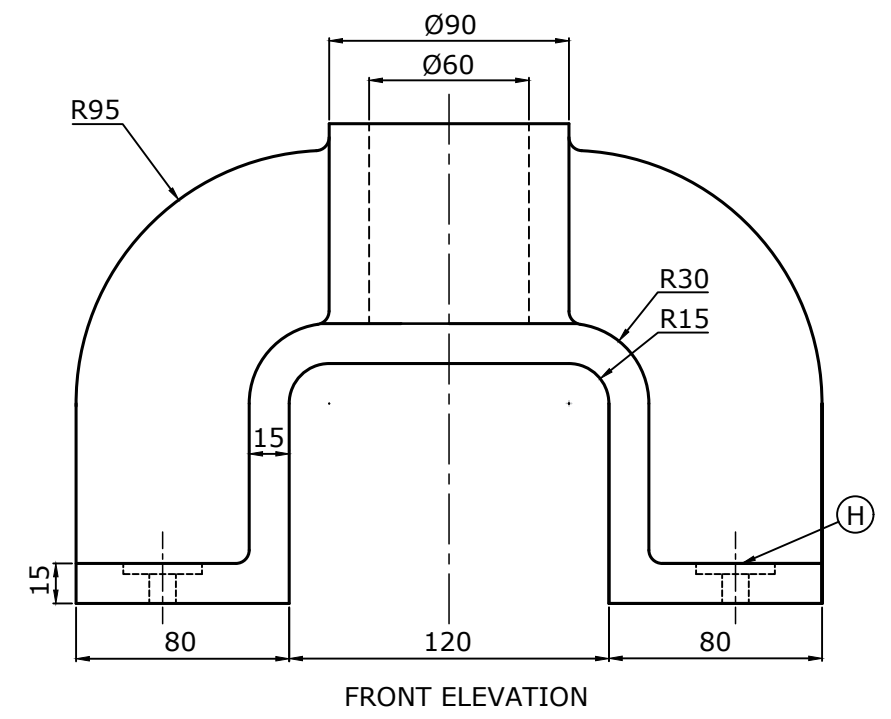
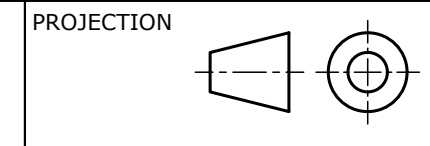

Figure 9c



SHAFT SUPPORT FRAME
Figure 6b



PROJECTION

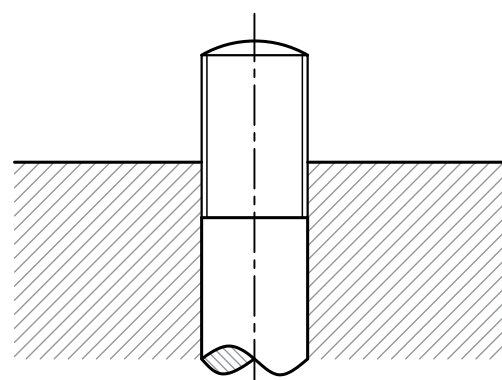
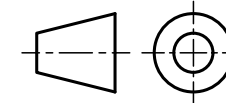

FRONT ELEVATION

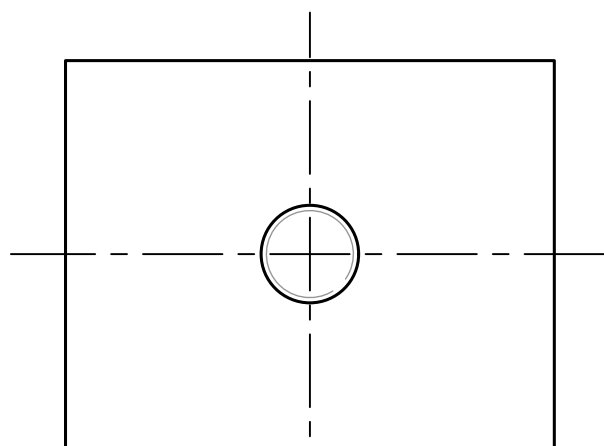

PLAN

Figure 7a

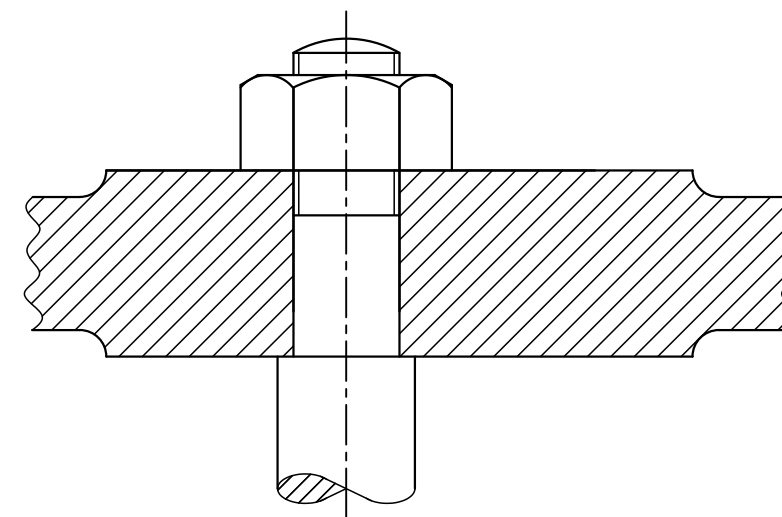

FRONT ELEVATION

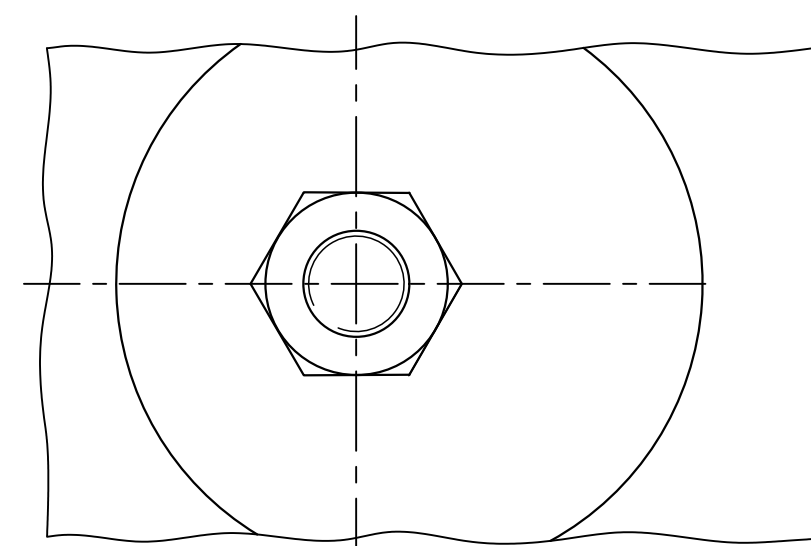

PLAN

Figure 7b



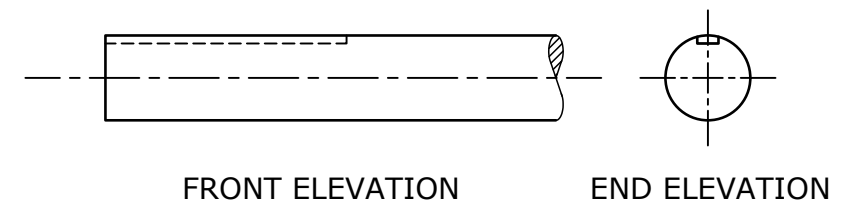
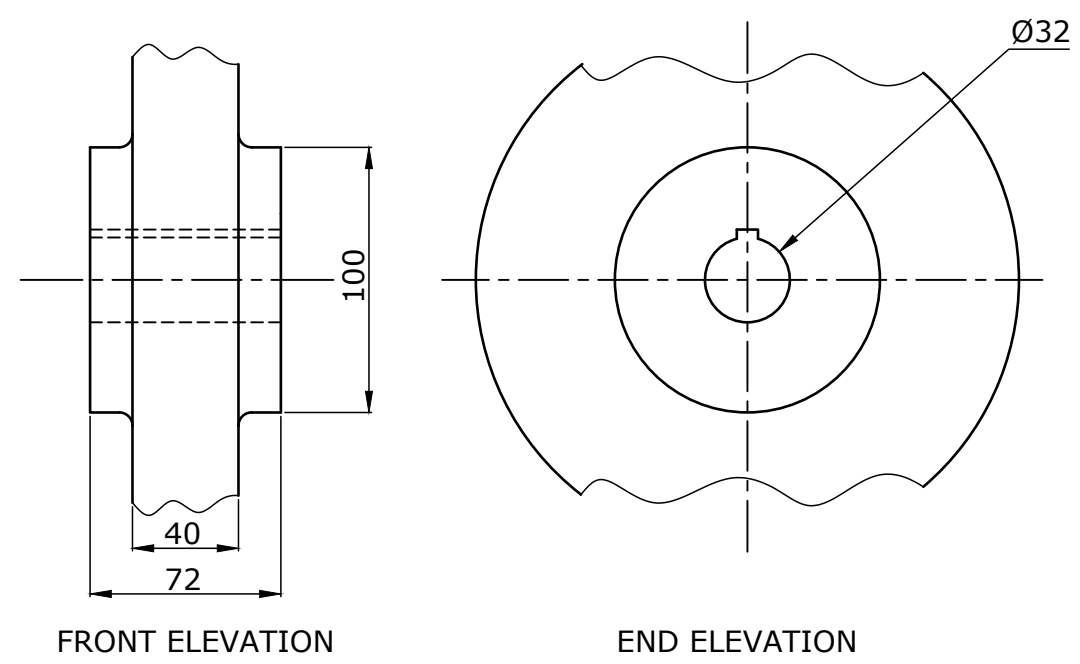

32 mm DIAMETER SHAFT

Figure 7c

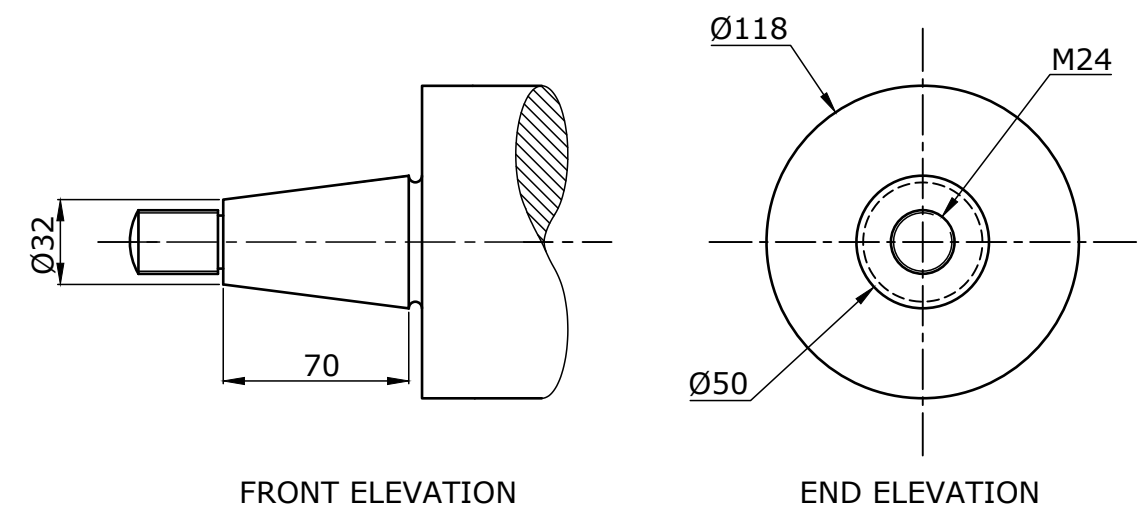
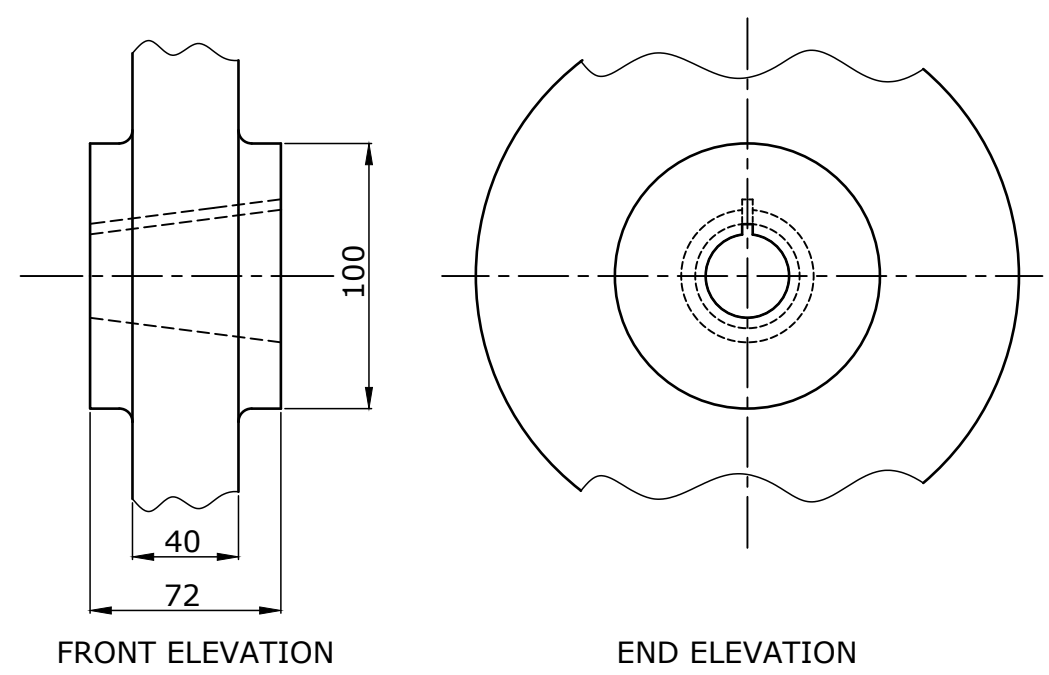

TAPERED END OF SHAFT

Figure 7d



QUESTION No. 7	SESSION:	SCALE:
PAPER No: IM09.23s	DATE: 5 - 9 - 2023	SHEET OF