



SUBJECT:	Pure Mathematics
DATE:	11 th October 2021
TIME:	4:00 p.m. to 7:05 p.m.

Directions to Candidates

Answer **ALL** questions. There are **10** questions in all.
 The total number of marks for all the questions in the paper is 100.
 Graphical calculators are **not** allowed.
 Scientific calculators can be used, but all necessary working must be shown.
 A booklet with mathematical formulae is provided.

1. (a) Show that

$$\frac{x^2}{(2x+1)(x+2)^2} \equiv \frac{1}{9(2x+1)} + \frac{4}{9(x+2)} - \frac{4}{3(x+2)^2}.$$

[3]

(b) Hence find $\int \frac{x^2}{(2x+1)(x+2)^2} dx$.

[3]

(c) Find the value of the integers a , b and c such that

$$\int_0^1 \frac{x^2}{(2x+1)(x+2)^2} dx = \frac{1}{18}(a \ln 2 + b \ln 3 + c).$$

[4]

[Total: 10 marks]

2. (a) Solve the differential equation

$$\sin 2x \frac{dy}{dx} = (y + 1) \cos 2x,$$

where $0 < x < \frac{1}{2}\pi$, given that $y = 0$ when $x = \frac{1}{12}\pi$.

[5]

(b) A curve is given by the equation $y = x^3 - 2x^2 + 5$.

(i) Find the gradient of the normal to the curve at the point (2, 5).

(ii) Find the equation of the normal to the curve at the point (2, 5).

[3, 2]

[Total: 10 marks]

3. The figure shows a tank in the shape of a cone filled with water. The tank leaks water at a constant rate of $2 \text{ m}^3/\text{hr}$. The radius of the top of the tank is 5 m and the height of the tank is 14 m.

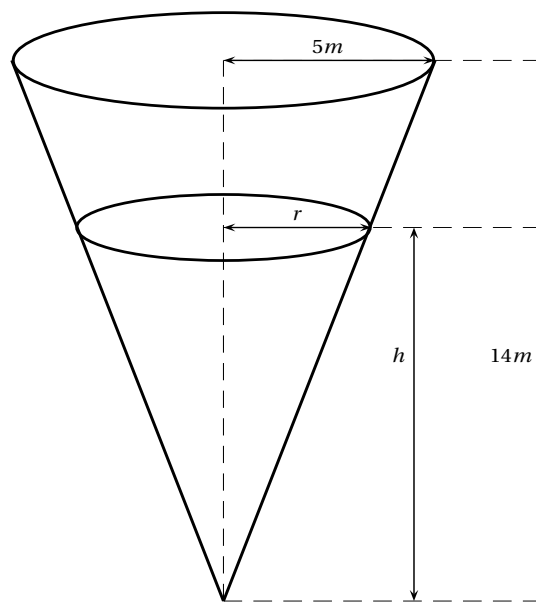

(a) The water in the tank forms a smaller cone. If h is the height of the water at time t , find the radius r of the top of the water in terms of h .

[2]

(b) Find the rate of change of the height of the water in the tank at the instant when the height of the water is 6 m. Give your answer correct to four significant figures.

[5]

(c) Find the rate of change of the radius of the top of the water in the tank when the height of the water is 6 m. Give your answer correct to four significant figures.

[3]

[Total: 10 marks]

4. (a) The third and ninth terms of a geometric progression are 8 and $\frac{1}{8}$, respectively.
- (i) Find the possible values of the common ratio.
 - (ii) Given that the second term is positive, find the sum to infinity of the progression. [2, 2]
- (b) In a bag there are four white (W) disks, six black (B) discs and five red (R) discs, all of the same size. Jeff takes one disc out of the bag at random, writes down on a piece of paper 'W', 'B' or 'R' according to its colour, and puts it back in the bag. This procedure is repeated three times to obtain a 3-letter code. Giving your answer correct to three decimal places, find the probability that the 3-letter code obtained contains:
- (i) the three letters W, B and R (in any position).
 - (ii) only one letter W and this is in the first position. [3, 3]

[Total: 10 marks]

5. (a) Write down the matrix **A** representing a reflection in the line $y = -x$. [2]
- (b) Write down the matrix **B** representing a reflection in the line $y = 0$. [2]
- (c) Find the matrices **C** = **AB** and **D** = **BA**. [4]
- (d) Interpret the two matrices **C** and **D** geometrically. [2]

[Total: 10 marks]

6. (a) Prove that if $x^2 > k(x - 2)$ for all real x , then $0 < k < 8$. [4]
- (b) Find the value of k if $2x + 1$ is a factor of $f(x) = 2x^3 + 5x^2 + kx - 24$ and hence factorise $f(x)$ fully. [6]

[Total: 10 marks]

7. (a) Rationalise the denominator of $\frac{\sqrt{15}}{3-\sqrt{5}}$. [2]
- (b) Giving your answer correct to two decimal places, solve $2^{x+2} = 3^{x-1}$. [3]
- (c) The logarithm of the area of a sector is equal to half the logarithm of its arc length.
- (i) Show that the radius r and the angle θ that is subtended at the centre of the sector satisfy $r^3\theta = 4$.
- (ii) Find the values of θ and r given that the area of this sector is equal to its arc length. [3, 2]
- [Total: 10 marks]**

8. (a) Solve the following equation for all values of $\theta \in [-180^\circ, 180^\circ]$.
- $$1 + 2 \sin \theta \cos \theta - \cos^2 \theta = 0$$
- Give your answer correct to two decimal places. [5]
- (b) Find the area enclosed between the curve $y = x^2 - 2$ and the line $y = x$. [5]
- [Total: 10 marks]**

9. (a) Find the derivative of $\ln x \cos^2 x$. [2]
- (b) Let $f(x) = (a + bx)^n$ where a, b and n are positive integers. Given that the binomial expansion of $f(x)$ is equal to
- $$16 + px + qx^2 + rx^3 + 81x^4,$$
- find the values of n, a, b, p, q and r .
- Hence, evaluate $(-2 - \sqrt{3})^4$, giving your answer in surd form. [5, 3]
- [Total: 10 marks]**

10. (a) On the same set of axes draw the graphs $y = \cos x$ and $y = \sin x$ for $0 \leq x \leq 2\pi$. [3]
- (b) Find the values of $x \in [0, 2\pi]$ for which $\sin x = \cos x$. Use your graphs to find the values $x \in [0, 2\pi]$ for which $\sin x \geq \cos x$. [2]
- (c) Calculate the area above the x-axis and under the graph of $y = \sin x - \cos x$ for $0 \leq x \leq 2\pi$. [5]
- [Total: 10 marks]**