



SUBJECT:	Engineering Technology
UNIT:	2
ASSIGNMENT:	3 – Controlled
TITLE:	Mechanical Systems
DATE SET:	25 th April 2022
DEADLINE:	23 rd May 2022

General Instructions

- Lines provided for sub-questions (a) and (b) indicate the length expected in candidate's answers.
- Students are to autonomously answer sub-questions (c). Therefore, lines provided do **not** necessarily indicate the length and depth of the expected answer.
- Application criteria will be assessed in class.
- The time required to complete practical tasks will be communicated by the teacher.
- Answers may be either in English or in Maltese.

Candidate's Declaration of Authenticity

I, the undersigned, _____ (*Name and Surname*), declare that all the work I shall submit for this assignment will be my own.

I further certify that if I use the ideas, words, or passages from existing sources, I will quote those words or paraphrase them and reference them by making use of a reference system.

I am aware that should I submit work which is not mine, or work which has been copied from one or more sources, I will be penalised as per MATSEC Examinations Board policies related to plagiarism.

Candidate's Signature: _____

I.D. Card No.: _____

Date: _____

General Scenario

- An engineering company would like to employ several technicians.
- You applied for this job.
- The following test was given to assess knowledge on mechanical systems.
- Complete the following test by answering **ALL** the questions in the space provided.

SECTION A – WRITE-ON

Question 1

K-8 (4 marks)

A mechanical linkage is created by using several systems. It is used to manage force and movement.

a. Label the different lever classes given in Table 1.

Table 1 - Lever Types

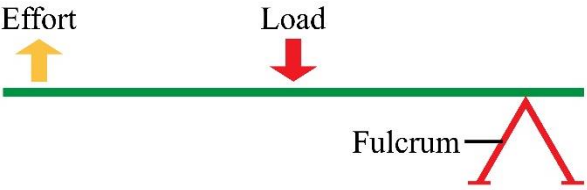
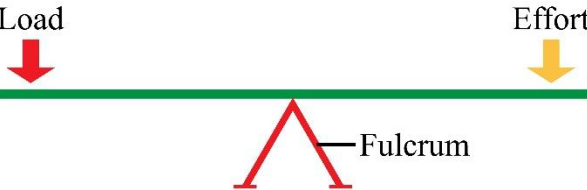
	Type of Levers	Lever Class
i.		<hr/>
ii.		<hr/>

(Source: <https://www.shutterstock.com/>)

b. Identify the different linkages in lever systems given in Table 2. Use words from the ones provided below.

reversing parallel motion bell crank push-pull

Table 2 – Linkages in lever systems

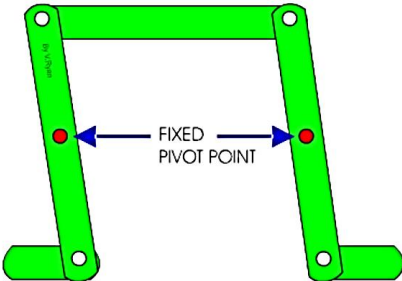
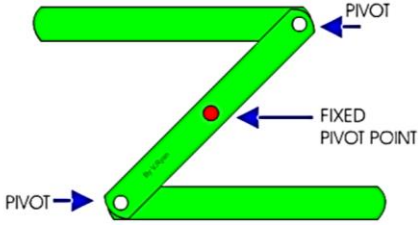
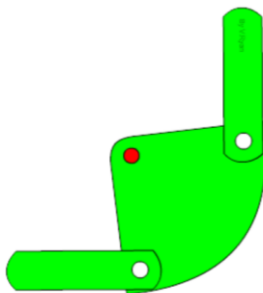
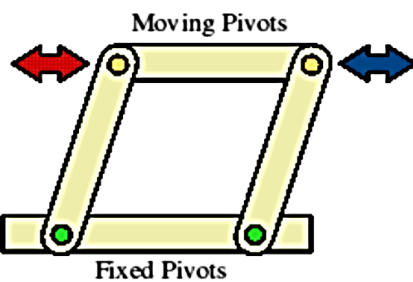
	Lever Systems	Type of Linkage
i.		<hr style="width: 80%; margin: 0 auto;"/>
ii.		<hr style="width: 80%; margin: 0 auto;"/>
iii.		<hr style="width: 80%; margin: 0 auto;"/>
iv.		<hr style="width: 80%; margin: 0 auto;"/>

(Source: <https://technologystudent.com/cams/link1.htm>)

c. Describe the output for the linkage system given in Figure 1.

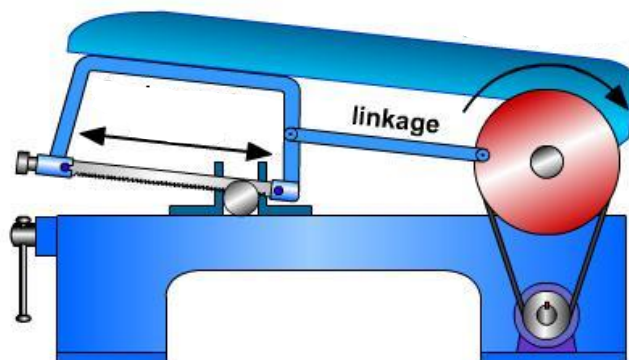
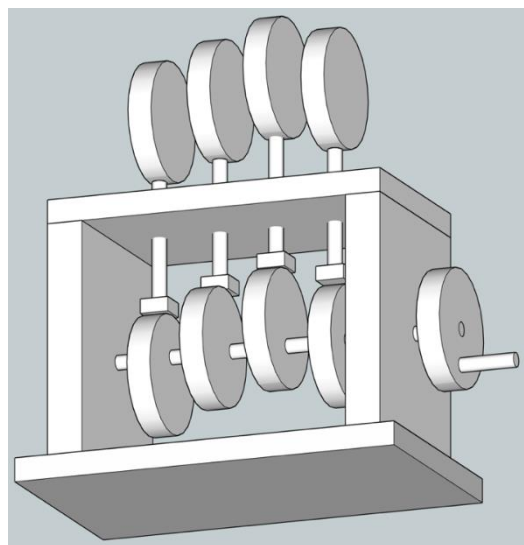
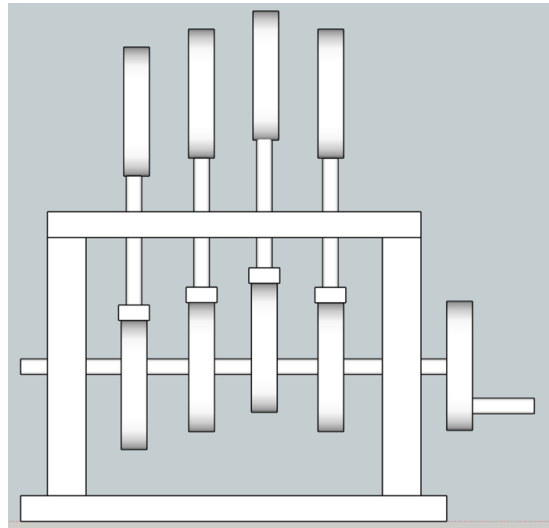
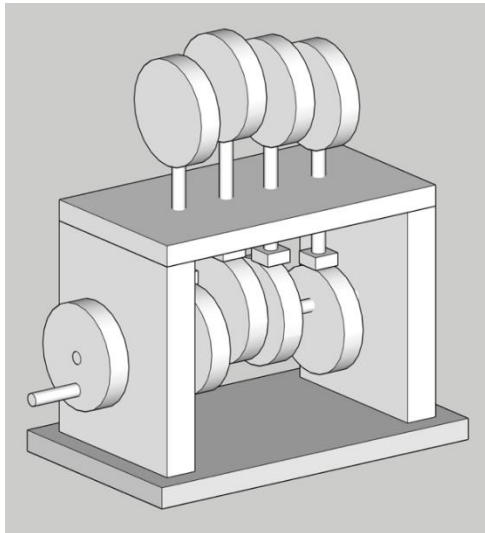

Figure 1: Linkage system

(Source: <https://www.notesandsketches.co.uk/Linkages.html>)

SECTION B - PRACTICAL**Background Information**

- You are requested to construct appropriate cams and crank systems to assemble and form the following cam toy shown in the images below.
- You are required to:
 - Construct the housing for the cam and crank systems to given specifications.
 - Construct appropriate cams and crank assemblies according to given specifications.
- The teacher will provide you with the necessary tools, equipment and material required to conduct this exercise.
- During this practical task, you should observe all Health and Safety Procedures and use your own adequate PPE.



SECTION B – PRACTICAL

Question 1

A-4 (10 marks)

- a. From the tools available in the workshop prepare the appropriate tools/equipment and the necessary PPEs for their use during the task.

The following are Questions 1b. and 1c. and should be worked out together.

- Construct the housing for the cam and crank system;
- Construct appropriate cams and crank assemblies to complete the toy.

The teacher will be giving you the necessary materials to construct the housing and the mechanical parts. Use the drawings given below as reference.

- i. Drill necessary holes at the sides and top of the housing as shown in Diagram 1.

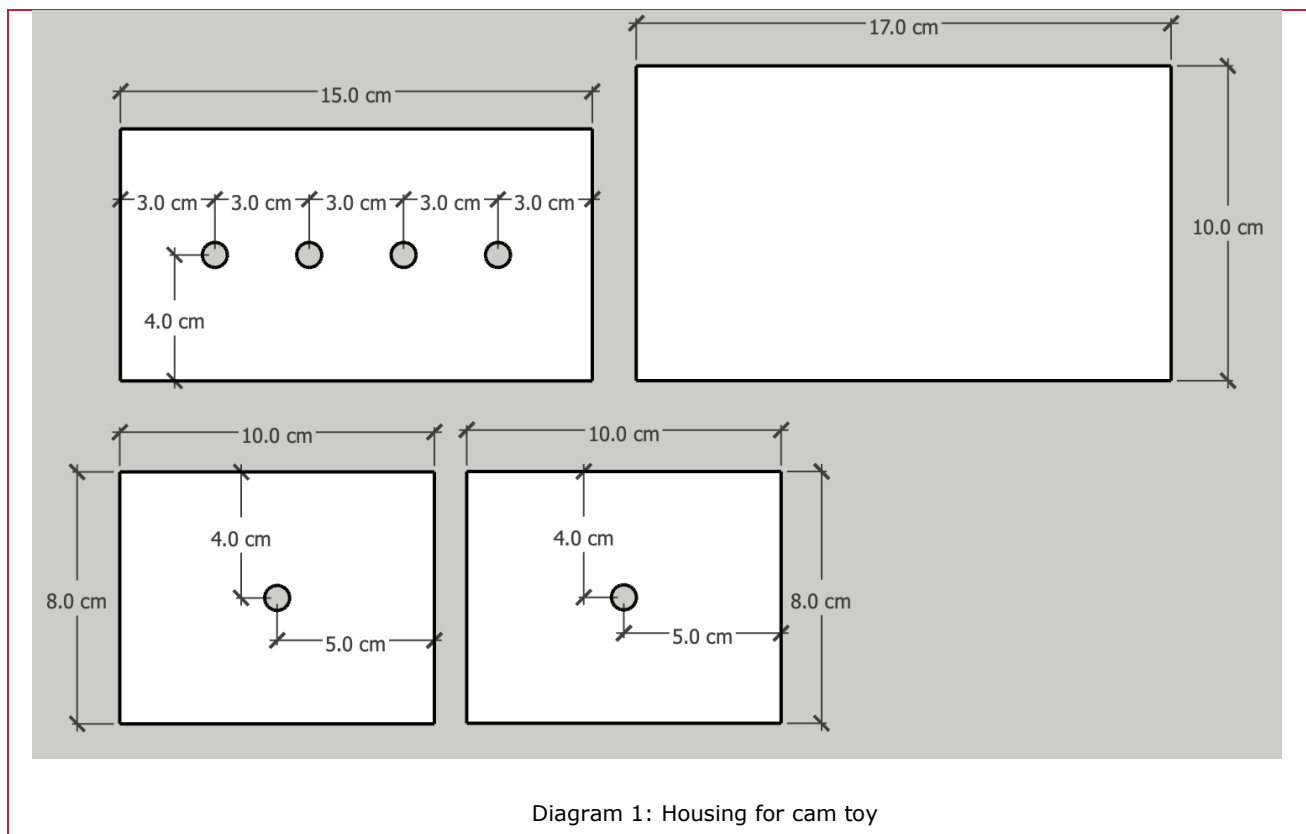

- ii. Construct the first part forming the housing for the cam system. Ensure precise and accurate work to a tolerance $\pm 5\text{mm}$ as shown in Diagram 2.

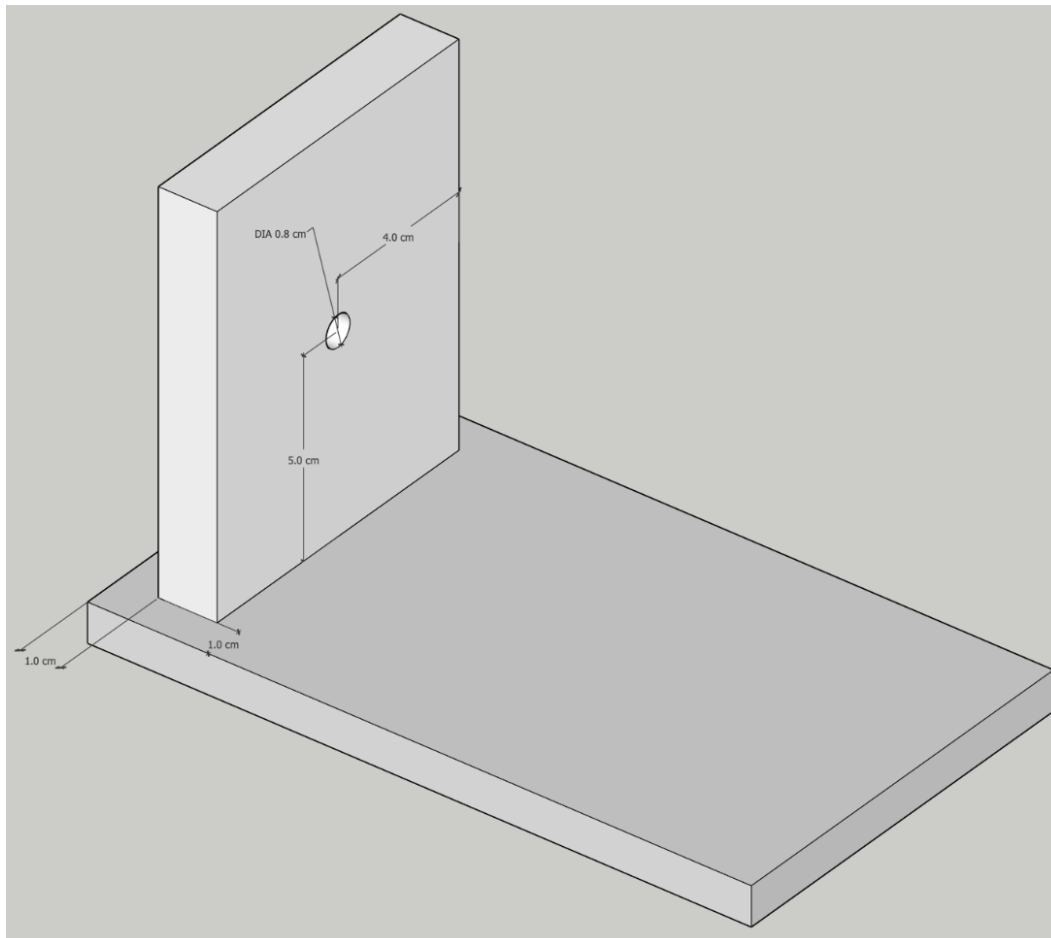

Diagram 2: Housing for cam toy

- iii. Use glue to mount the cams to the shaft according to the dimensions shown in Diagram 3.

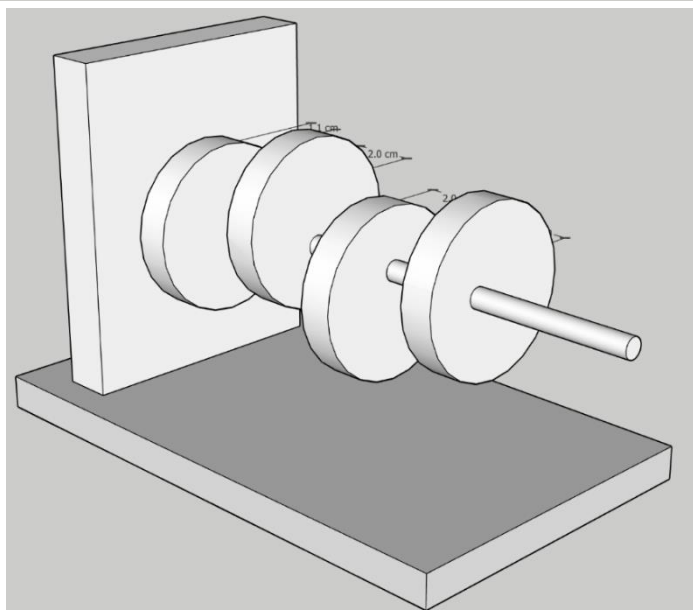
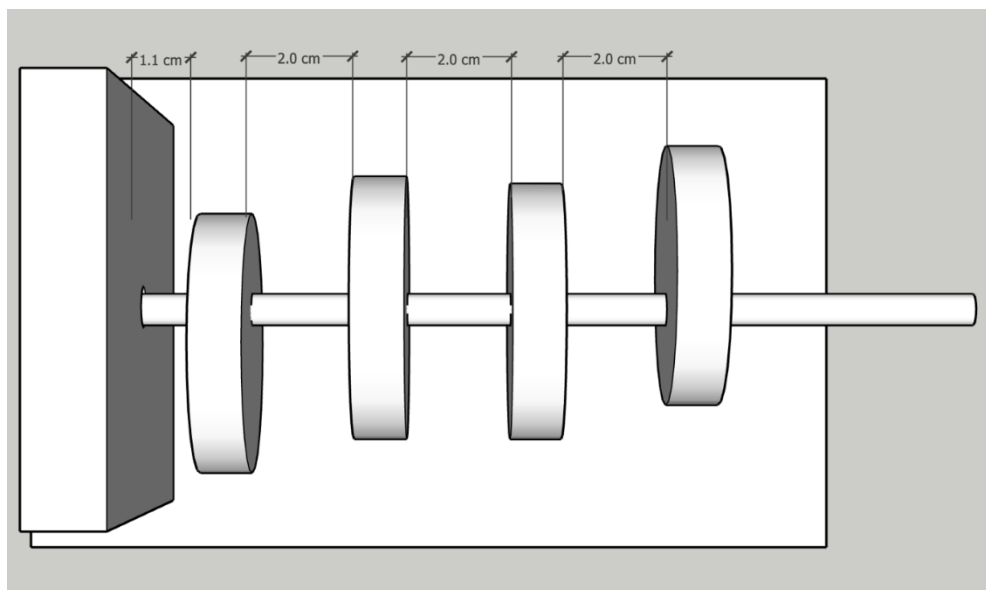

Diagram 3: Mounting cam to shaft

- iv. Mount and glue the followers to the dowels as shown in Diagram 4 and prepare the top cover.

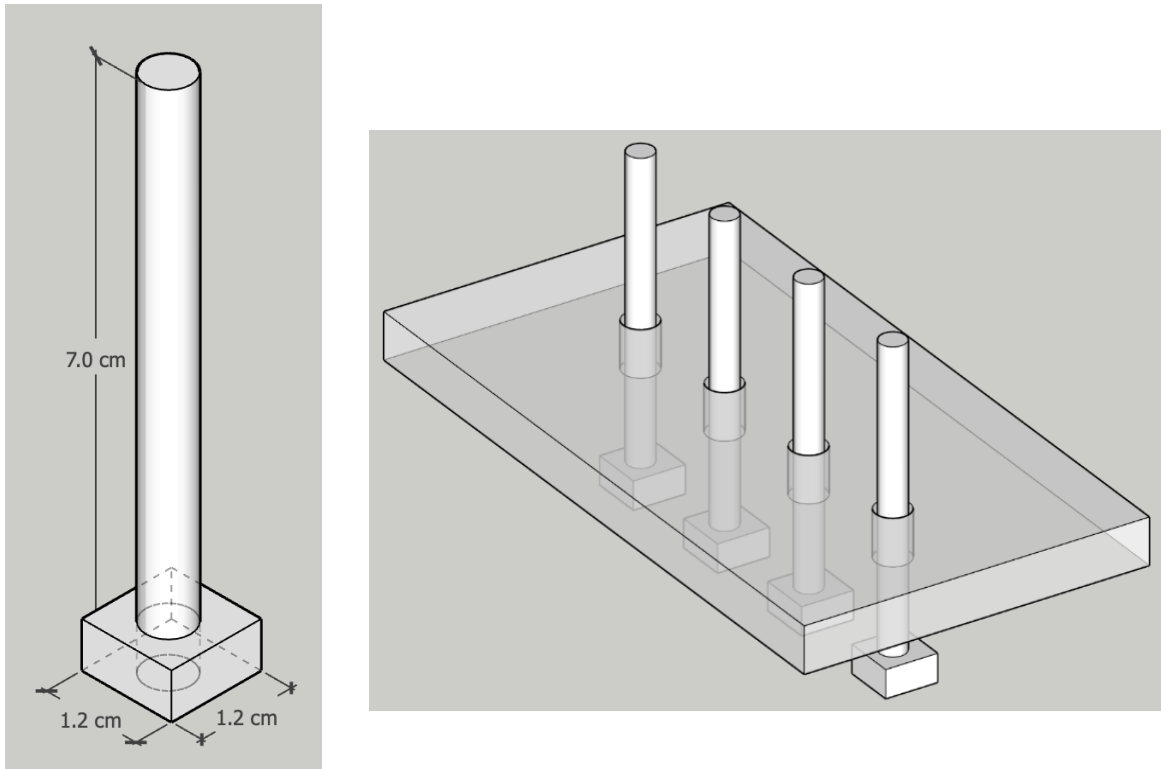

Diagram 4: Mounting followers to dowels

- v. Drill holes of suitable diameter on the edge of the **FOUR** circles to be used for the top part as shown in Diagram 5.

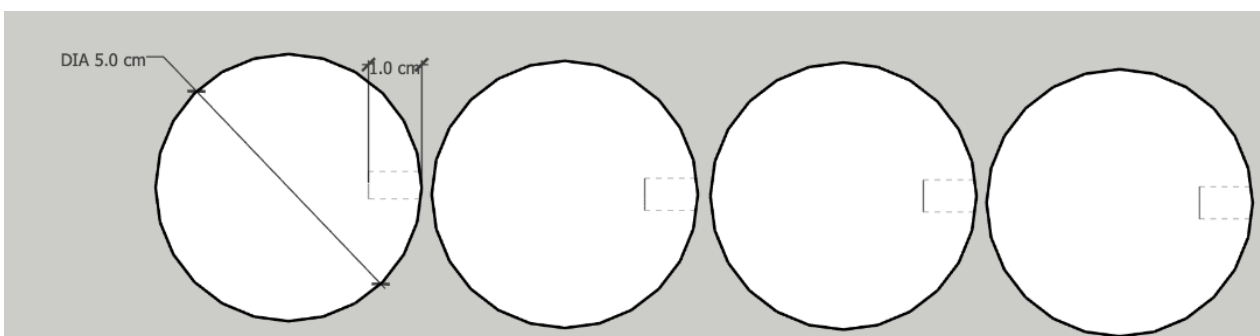

Diagram 5: Top circles

- vi. Complete the toy by gluing the top circles and the control circle and its lever.
- vii. Affix the top cover, front and followers to the remaining of the toy as shown in Diagram 6.
- viii. Ensure the functionality of the toy.

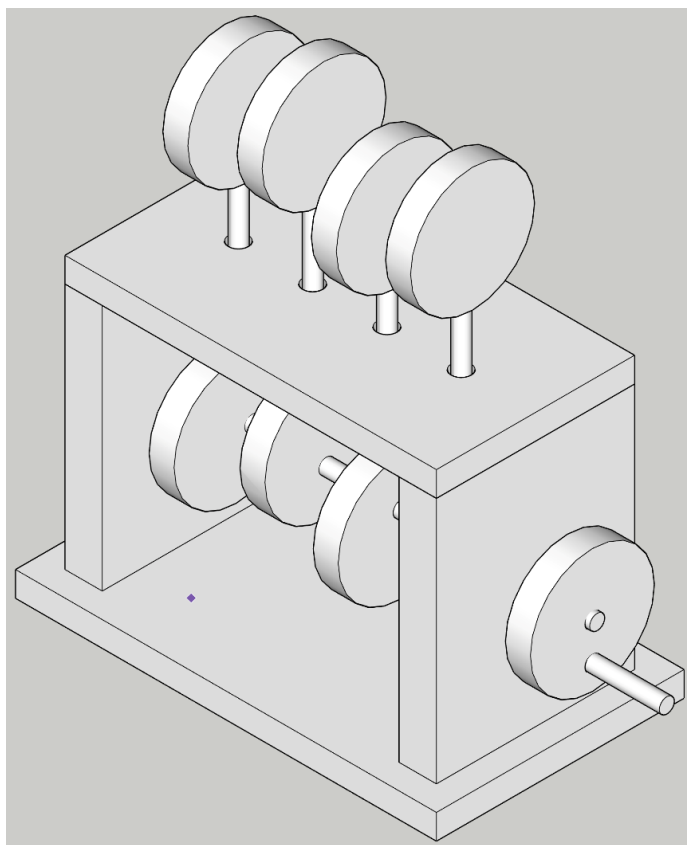
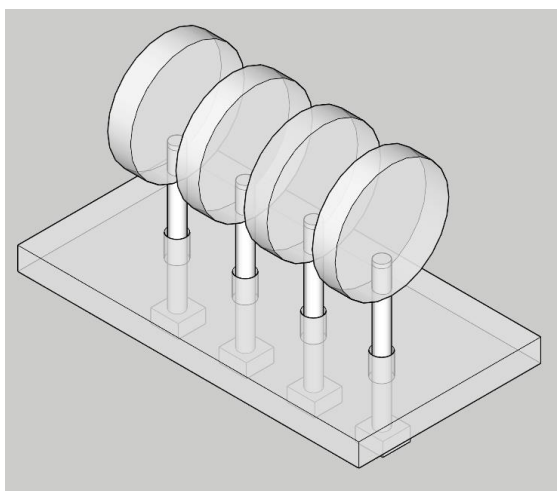
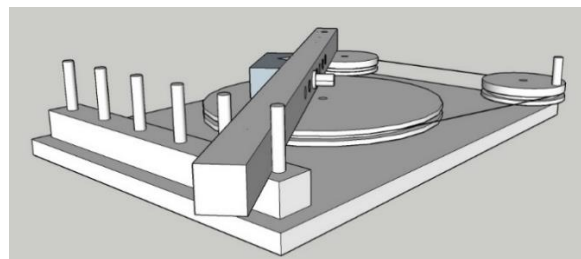
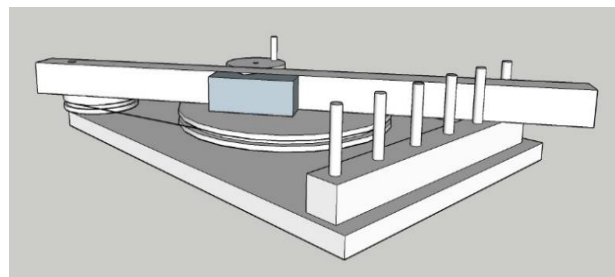
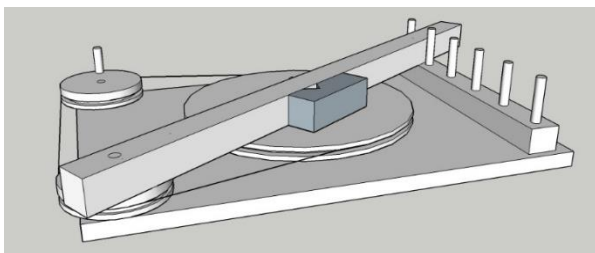
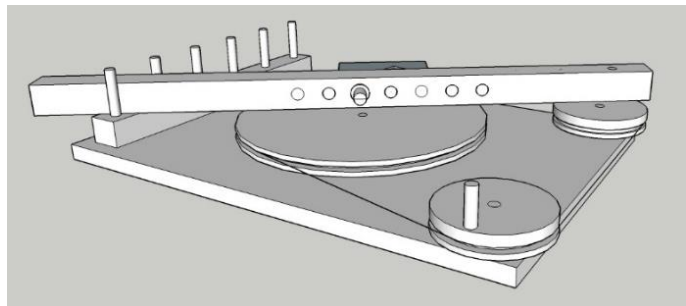
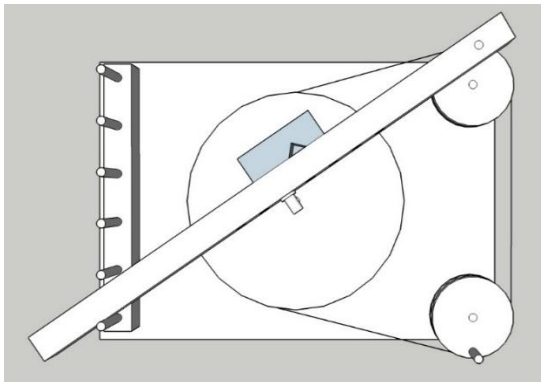

Diagram 6: Complete cam toy

SECTION C - PRACTICAL

Background Information

- You are requested to construct a drawing machine composed of a number of mechanical sub-systems. The following drawings showing the machine from different angles. A labelled drawing (Diagram 7) is also included.
- You are required to follow the instructions and:
 - Construct the housing for the different mechanical sub-systems.
 - Construct a mechanical system composed of different mechanical sub-systems.
 - Assemble all parts. The machine should produce patterns according to the setting of the moving arm.
- The teacher will provide you with the necessary tools, equipment and material required to conduct this exercise.
- During this practical task, you should observe all Health and Safety Procedures and use your own adequate PPE.



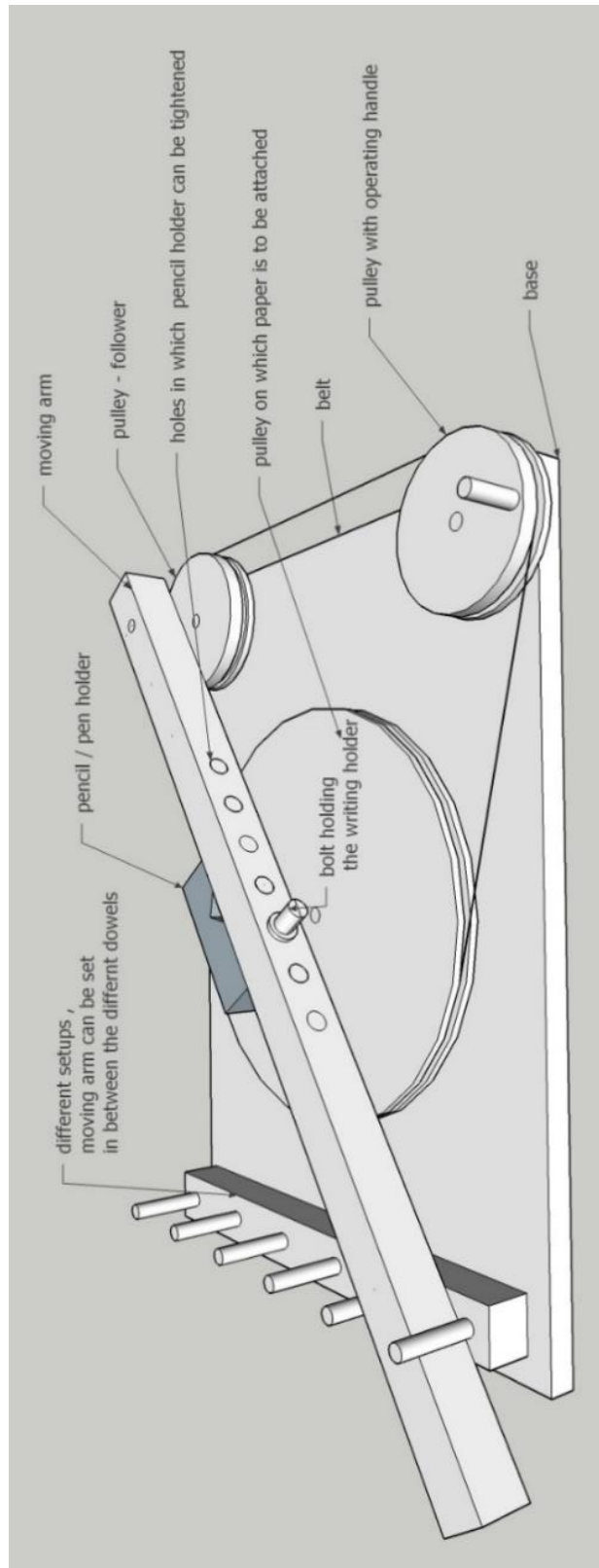

Diagram 7: Drawing machine

SECTION C - PRACTICAL

Question 1

A-5 (10 marks)

- a. From the tools available in the workshop prepare the appropriate tools/equipment, material and the necessary PPEs for their use during the task.

The following are Questions 1b. and 1c. and should be worked out together.

- Construct the housing for the mechanical systems.
- Build the drawing machine composed of different mechanical sub-systems.

The teacher will be giving you the necessary materials to construct the housing and the mechanical parts. Ensure precise and accurate work to a tolerance of +/- 5mm. Use the drawings given below as reference to:

- i. Drill holes in the side bar and housing (base). Use the drawings in Diagram 8 as reference.

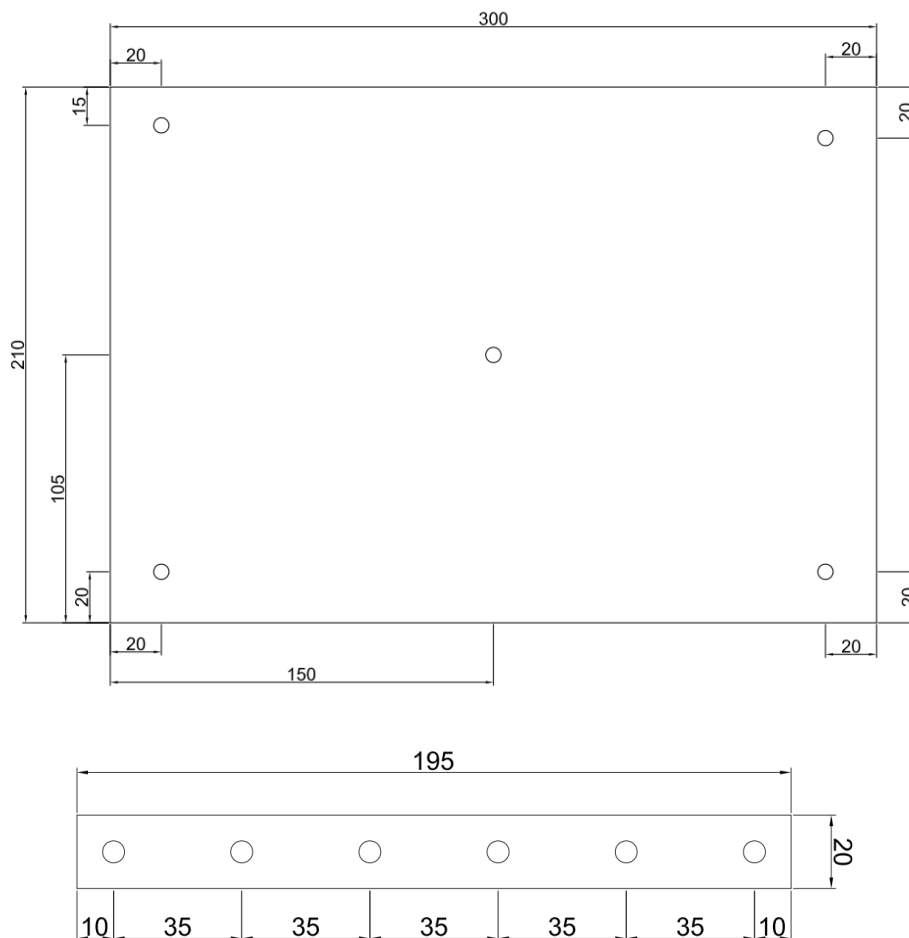

Diagram 8: Side bar and housing (base)

- ii. Insert and glue the M6 dowels.
 - 47mm dowels for the end holes of the side bar
 - 57mm dowels for the remaining holes

- iii. Drill the appropriate holes in the provided circles as shown in Diagram 9.
Ensure precise and accurate work to a tolerance of $\pm 5\text{mm}$ and $\pm 3^\circ$.

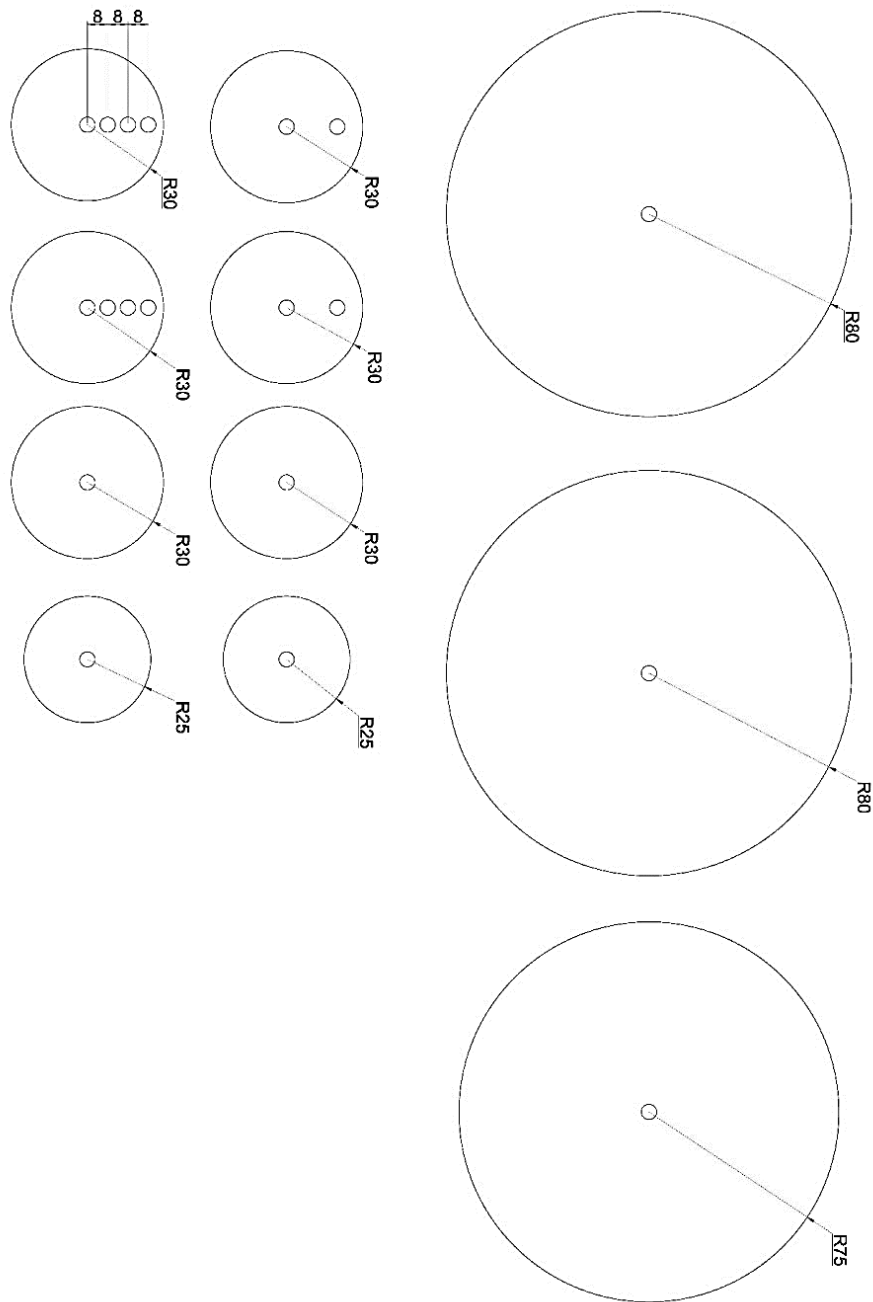

Diagram 9: Circles for pulleys

- iv. Glue the circles to form the pulley with the operating handle – be careful to align the centre.
 - 2x R30 (with two holes)
 - 1x R25 (with one hole)
 - 1x R30 (with one hole)

- v. Glue the circles to form the follower pulley – be careful to align the centre.
 - 2x R30 (with four holes)
 - 1x R25 (with one hole)
 - 1x R30 (with one hole)

- vi. Glue the large circles to form the pulley on which paper is to be attached – be careful to align the centre.
 - 2x R80 (with one hole)
 - 1x R75 (with one hole)

- vii. Glue the dowel to form the crank on the pulley with the operating handle.

- viii. Construct the moving arm according to the dimensions given in Diagram 10 below:
 - Prepare the arm to length
 - Drill indicated holes

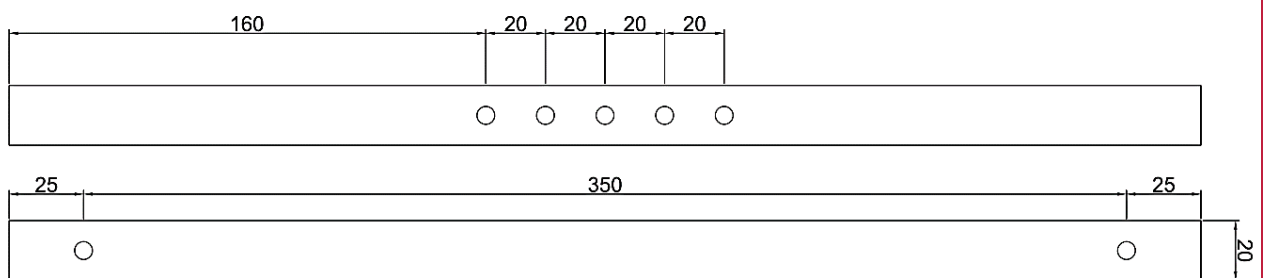
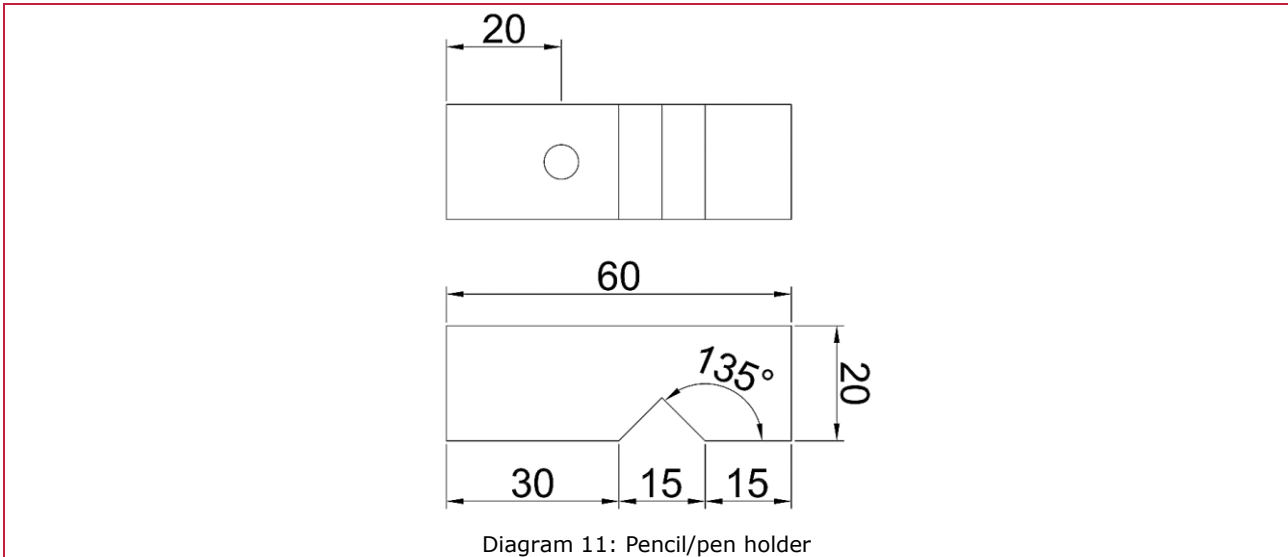

Diagram 10: Moving arm

ix. Construct the Pencil/pen holder according to the dimensions given in Diagram 11 below:

- Cut to shape as indicated
- Drill indicated hole



x. Assemble all parts according to drawing in Diagram 7:

- Mount rubber band
- Fix a piece of paper on the biggest pulley with masking tape
- Assemble a pen/pencil

xi. Ensure functionality - Machine should produce patterns according to the setting the moving arm is set at.

SECTION D – WRITE-ON

Question 1

C-3 (6 marks)

Different mechanical systems were used to construct the drawing machine. Answer the following questions using the mechanical system constructed in Section C Question 1.

- a. Classify the given parts into the following parameters: 'input and output' or 'process' by ticking ✓ the corresponding boxes below.

	Input and/or output	Process
Pulley with operating handle	<input type="checkbox"/>	<input type="checkbox"/>
Moving arm	<input type="checkbox"/>	<input type="checkbox"/>

- b. Describe the parameters of the mechanical system you constructed in Section C Question 1.

Input and Output: _____

Process: _____

- c. Explain the parameters of the mechanical system constructed in Section C Question 1 by stating how and why the sub-mechanical systems work to produce the required result.

