

MATRICULATION AND SECONDARY EDUCATION CERTIFICATE EXAMINATIONS BOARD  
UNIVERSITY OF MALTA, MSIDA

**SECONDARY EDUCATION CERTIFICATE LEVEL**

**SEPTEMBER 2017 SESSION**

---

SUBJECT:	Chemistry
PAPER NUMBER:	I
DATE:	30 <sup>th</sup> August 2017
TIME:	9:00 a.m. to 11:05 a.m.

---

**Useful data:**

Relative atomic masses: H = 1; O = 16; Cl = 35.5; Cu = 63.5; Ba = 137

$Q = It$

1 Faraday = 96500 C

Standard temperature and pressure (stp): 0 °C and 1 atm

The molar volume for gases at stp = 22.4 dm<sup>3</sup>

---

**Directions to Candidates**

- Write your index number in the space at the top left-hand corner of this page.
  - Answer **ALL** questions. Write all your answers in the spaces provided in this booklet.
  - Write all your answers in the spaces provided in this booklet.
  - The mark allocation is indicated at the end of each question. Marks allocated to parts of questions are also indicated in brackets.
  - You are reminded of the necessity for orderly presentation in your answers.
  - In calculations you are advised to show all the steps in your working, giving your answer at each stage.
  - The use of electronic calculators is permitted.
  - A Periodic Table is printed on the back of this booklet.
- 

**For examiners' use only:**

Question	1	2	3	4	5	6	7	8	9	10	11	12	Total
Score													
Maximum	6	6	6	6	6	6	6	6	6	6	20	20	100

**SECTION A**

Answer ALL questions in this Section. Write your answers in the spaces provided.

1. Table 1 below shows several substances. Next to each of them, write element, compound or mixture as appropriate. The first one has been filled in as an example.

Table 1

	Substance	Element, compound, or mixture
	steam	compound
(a)	sodium	
(b)	iron filings and sulfur in a test tube	
(c)	iodine	
(d)	sulfuric acid	
(e)	air	
(f)	ozone	

(Total: 6 marks)

6

2. Chlorine-35 and Chlorine-37 are isotopes of chlorine.

(a) What are isotopes?

\_\_\_\_\_ (2)

(b) Which **ONE** of the two isotopes of chlorine is normally present in larger amounts?

\_\_\_\_\_ (1)

(c) Hydrogen and chlorine react together to form gaseous hydrogen chloride.

(i) Give a balanced equation for the reaction.

\_\_\_\_\_ (2)

(ii) Why must there be **no** water or water vapour present?

\_\_\_\_\_ (1)

(Total: 6 marks)

6

3.

(a) Draw dot-cross diagrams, showing outer electrons only, to clearly show the bonding in:

(i) sodium chloride, NaCl;

(2)

(ii) ammonia, NH<sub>3</sub>.

(2)

(b)

(i) Name the type of bonding present in ammonia.

(1)

(ii) Why is ammonia a non-conductor of electricity?

(1)

**(Total: 6 marks)**

4.

(a) Copper metal reacts with silver nitrate, AgNO<sub>3</sub>, solution.

(i) Give a balanced equation for this reaction.

(2)

(ii) What is the type of chemical reaction in part (a)(i) called?

(1)

(b) Copper(II) oxide, being a base, can react with acids.

(i) Give a balanced equation for the reaction of copper(II) oxide, CuO, with dilute sulfuric acid, H<sub>2</sub>SO<sub>4</sub>.

(2)

(ii) Although copper(II) oxide is a base, it shows **no** effect on red litmus paper. Explain.

(1)

**(Total: 6 marks)**

6

6

5.

- (a) Sodium carbonate crystals are efflorescent. Give a balanced chemical equation to explain the meaning of efflorescent using sodium carbonate crystals,  $\text{Na}_2\text{CO}_3 \cdot 10\text{H}_2\text{O}$ , as an example.

\_\_\_\_\_ (2)

- (b) Calculate the percentage of barium chloride in  $\text{BaCl}_2 \cdot 2\text{H}_2\text{O}$ .

\_\_\_\_\_

\_\_\_\_\_

\_\_\_\_\_ (3)

- (c) When table salt, sodium chloride, is placed in an open container, after some time, the crystals seem to stick together and the total mass increases. Give **ONE** reason for this behaviour.

\_\_\_\_\_ (1)

**(Total: 6 marks)**

6

6. Sodium and iron are both metals but they behave very differently when they are in contact with water.

(a)

- (i) A very small piece of sodium is very carefully added to some water in a boiling tube. Give a balanced equation to show the reaction of sodium with cold water.

\_\_\_\_\_ (2)

- (ii) What effect, if at all, will there be if, after the reaction in part (i), red and blue litmus papers are placed in the boiling tube?

• Effect on red litmus paper: \_\_\_\_\_

• Effect on blue litmus paper: \_\_\_\_\_

(2)

- (b) Iron, unlike sodium, does **not** react with cold water but reacts with steam. Give a balanced equation for this reaction.

\_\_\_\_\_ (2)

**(Total: 6 marks)**

6

7. Energy level diagrams, (energy profiles), are a convenient way of representing the energy changes that take place during exothermic and endothermic reactions.

(a) In the space below draw a labelled energy level diagram for an exothermic reaction. The diagram must clearly show the (i) reactants, (ii) products, (iii) heat of reaction (enthalpy change), and (iv) activation energy.

(4)

(b) On the same diagram in part (a), draw an unlabelled energy level diagram if a catalyst is used for the reaction in part (a).

(1)

(c) In the space below draw an unlabelled energy level diagram for an endothermic reaction.

(1)

**(Total: 6 marks)**

6

*Please turn the page.*

8. The structural formulae of three hydrocarbons are shown in Table 2.

(a) Complete Table 2 to give the name of each substance.

Table 2

	Substance A	Substance B	Substance C
Formula	$\begin{array}{c} \text{H} \\   \\ \text{H}-\text{C}-\text{H} \\   \\ \text{H} \end{array}$	$\begin{array}{ccccc} \text{H} & \text{H} & \text{H} & & \\   &   &   & & \\ \text{H}-\text{C} & -\text{C} & -\text{C}-\text{H} & & \\   &   &   & & \\ \text{H} & \text{H} & \text{H} & & \end{array}$	$\begin{array}{ccccccccc} \text{H} & \text{H} & \text{H} & \text{H} & \text{H} & & & & \\   &   &   &   &   & & & & \\ \text{H}-\text{C} & -\text{C} & -\text{C} & -\text{C} & -\text{C}-\text{H} & & & & \\   &   &   &   &   & & & & \\ \text{H} & \text{H} & \text{H} & \text{H} & \text{H} & & & & \end{array}$
Name			

(3)

(b) These substances belong to a particular homologous series. Give the name of this series.

(1)

(c) Substances **A**, **B**, and **C** have different physical properties.

(i) Write compounds **A**, **B**, and **C** in order of increasing boiling point.

(1)

(ii) Explain your answer.

(1)

**(Total: 6 marks)**

9. The temperature, volume, and pressure of a gas are related to one another.

(a) Calculate:

(i) the new pressure exerted when a sample of  $50 \text{ cm}^3$  of methane at a pressure of  $1.5 \text{ atm}$  is expanded to a volume of  $150 \text{ cm}^3$  at constant temperature;

(2)

(ii) the new volume occupied by  $25.0 \text{ cm}^3$  of nitrogen at a temperature of  $273 \text{ K}$  when heated to  $300 \text{ K}$  at constant pressure.

(2)

6

- (b) Explain in terms of particles why the pressure exerted by a sample of oxygen in a closed container increases when the sample is heated.

6

(2)

**(Total: 6 marks)**

10. The equation for the reaction between ethanol and ethanoic acid is given below.

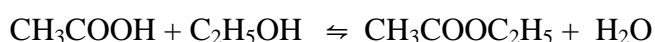

(a)

- (i) What type of substance is formed in this reaction besides water?

(1)

- (ii) What is the chemical name of this substance?

(1)

- (b) When carried out in the laboratory, this reaction reaches a state of equilibrium. What does this mean?

(1)

(c)

- (i) Give **ONE** way by which the position of the equilibrium can be changed so as to favour the formation of more product.

(1)

- (ii) Give a reason for your answer to part (c)(i).

(1)

- (d) During this reaction a catalyst is used. Why is a catalyst used?

(1)

**(Total: 6 marks)**

6

*Please turn the page.*

**SECTION B**

Answer ALL questions in this section. Write your answers in the spaces provided.

11.

(a) What range of pH values would each of the following solutions have?

Table 3

	<b>Solution</b>	<b>Range of pH values</b>
(i)	A strong acid	
(ii)	A weak acid	
(iii)	A neutral solution	
(iv)	A weak alkali	
(v)	A strong alkali	

(5)

(b) On adding lemon juice to a tea solution, the solution changes colour. Frank thinks that a tea solution could act as an acid-base indicator.

(i) Explain the term ‘indicator’.

(1)

(ii) Give steps for a simple experiment to test whether tea can act as an acid-base indicator.

(2)

(c) A winemaker uses a pH meter to measure the pH of red grape juice before fermentation. This has a value of 3.2.

(i) Why is it not practical to use a universal indicator to measure the pH of red grape juice?

(1)

(ii) As the juice ferments, the concentration of H<sup>+</sup> ions decreases slightly. Underline the pH of the wine after fermentation: 1.0 / 2.8 / 3.6 / 9.8

(1)



- (d) Table 4 shows chemical equations for the dissociation of some common laboratory acids. Complete Table 4 and use the information in Table 4 to answer the following questions.

Table 4

Hydrochloric acid	$\text{HCl (aq)} \rightarrow \text{H}^+ + \text{Cl}^-$
Nitric acid	$\text{HNO}_3 \text{ (aq)} \rightarrow \text{H}^+ + \text{NO}_3^-$
Ethanoic acid	$\text{CH}_3\text{COOH (aq)}$
Sulfuric acid	

(4)

- (i) Which of the above acids is a weak acid? Explain your answer.

\_\_\_\_\_

\_\_\_\_\_ (2)

- (ii) If all of the above acidic solutions have the same concentration, two of the above acids would have the same concentration of  $\text{H}^+$  ions. Identify these **TWO** acids. Explain your answer.

\_\_\_\_\_

\_\_\_\_\_ (2)

- (iii) If all of the above acidic solutions have the same concentration, which acid would have the highest concentration of  $\text{H}^+$  ions? Explain your answer.

\_\_\_\_\_

\_\_\_\_\_ (2)

**(Total: 20 marks)**

20

*Please turn the page.*

12. Consider the electrolysis of the following substances:

- A. dilute sulfuric acid solution;
- B.  $2 \text{ mol dm}^{-3}$  hydrochloric acid solution;
- C.  $2 \text{ mol dm}^{-3}$  sodium chloride solution;
- D. dilute copper(II) sulfate solution.

(a) Complete Table 5 below to give the name of the products that would be formed at the cathode and the anode when each of the solutions shown above were electrolysed using inert electrodes.

Table 5

	Solution being electrolysed	Product at the	
		cathode	anode
(i)	dilute sulfuric acid solution		
(ii)	$2 \text{ mol dm}^{-3}$ hydrochloric acid solution		
(iii)	concentrated sodium chloride solution		
(iv)	dilute copper(II) sulfate solution		

(8)

(b) Purification of copper is carried out by means of electrolysis as shown in the diagram below. A current of 2 A is passed through the solution for 10 minutes.

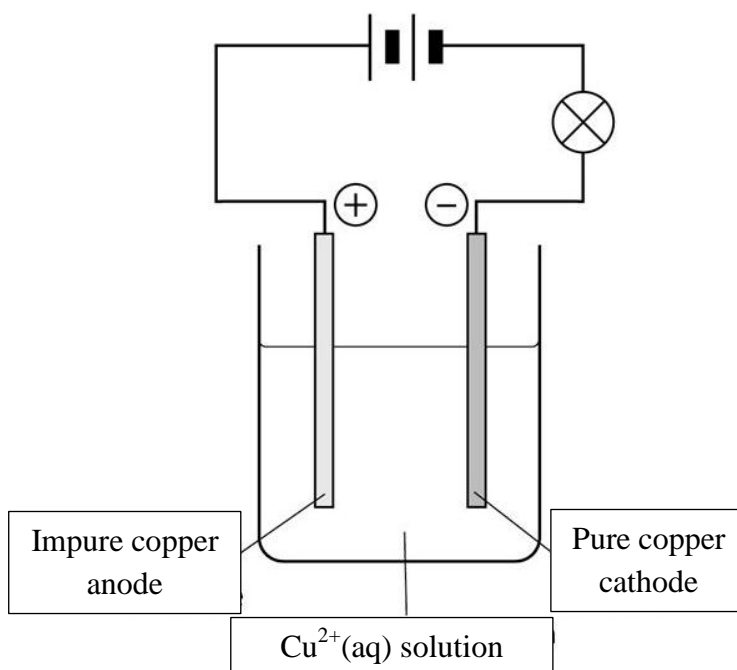

Adapted from: <http://slideplayer.com/slide/6109892/>

---

(i) Suggest a solution containing  $\text{Cu}^{2+}$  ions to be used for this experiment.

---

(1)

(ii) Give the half equation for the change taking place at the cathode.

---

(2)

(iii) If a current of 2 A is used for 10 minutes, calculate:

- the total charge used;

---

(2)

- the amount (in moles) of electrons used;

---

(2)

- the mass of copper deposited at the cathode.

---

(2)

(c) What would be observed after 24 hours if zinc powder is added to a:

(i) sodium chloride solution;

---

(1)

(ii) copper(II) sulfate solution.

---

(2)

**(Total: 20 marks)**

20

PERIODIC TABLE

I	II	III	IV	V	VI	VII	VIII
1 H 1	2 He 2						
3 Li 3	4 Be 4	5 B 5	6 C 6	7 N 7	8 O 8	9 F 9	10 Ne 10
11 Na 11	12 Mg 12	13 Al 13	14 Si 14	15 P 15	16 S 16	17 Cl 17	18 Ar 18
19 K 19	20 Ca 20	21 Sc 21	22 Ti 22	23 V 23	24 Cr 24	25 Mn 25	26 Fe 26
37 Rb 37	38 Sr 38	39 Y 39	40 Zr 40	41 Nb 41	42 Mo 42	43 Tc 43	44 Ru 44
55 Cs 55	56 Ba 56	57 La 57	58 Ce 58	59 Pr 59	60 Nd 60	61 Pm 61	62 Sm 62
87 Fr 87	88 Ra 88	89 Ac 89	90 Th 90	91 Pa 91	92 U 92	93 Np 93	94 Pu 94
101 Fm 101	102 Md 102	103 Lr 103	104 No 104	105 Nh 105	106 Fl 106	107 Mc 107	108 Lv 108
111 B 11	112 C 12	113 Al 13	114 Si 14	115 P 15	116 S 16	117 Cl 17	118 Ar 18
119 In 49	120 Sn 50	121 Sb 51	122 Te 52	123 I 53	124 Xe 54	125 At 85	126 Rn 86
133 Cs 55	134 Ba 56	135 La 57	136 Ce 58	137 Pr 59	138 Nd 60	139 Pm 61	140 Sm 62
151 Eu 63	152 Gd 64	153 Tb 65	154 Dy 66	155 Ho 67	156 Er 68	157 Tm 69	158 Yb 70
171 Lu 71	172 Hf 72	173 Ta 73	174 W 74	175 Re 75	176 Os 76	177 Ir 77	178 Pt 78
181 Au 79	182 Hg 80	183 Tl 81	184 Pb 82	185 Bi 83	186 Po 84	187 At 85	188 Rn 86
201 Hg 80	202 Tl 81	203 Pb 82	204 Bi 83	205 Po 84	206 At 85	207 Rn 86	208 Fr 87
223 Fr 87	224 Ra 88	225 Ac 89	226 Th 90	227 Pa 91	228 U 92	229 Np 93	230 Pu 94
239 Pu 94	240 Am 95	241 Cm 96	242 Bk 97	243 Cf 98	244 Es 99	245 Fm 100	246 Md 101
251 No 102	252 Lr 103	253 Nh 104	254 Fl 105	255 Mc 106	256 Lv 107	257 Ts 108	258 Og 109

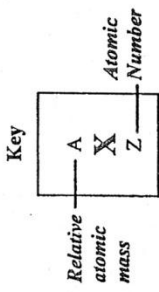

MATRICULATION AND SECONDARY EDUCATION CERTIFICATE EXAMINATIONS BOARD  
UNIVERSITY OF MALTA, MSIDA

**SECONDARY EDUCATION CERTIFICATE LEVEL**

**SEPTEMBER 2017 SESSION**

---

SUBJECT:	Chemistry
PAPER NUMBER:	IIB
DATE:	30 <sup>th</sup> August 2017
TIME:	4:00 p.m. to 6:05 p.m.

---

**Useful data:**

Relative atomic masses: H = 1; C = 12; O = 16; S = 32; Cl = 35.5

$$\Delta H = mc\Delta\Theta$$

Standard temperature and pressure (stp): 0 °C and 1 atm

The molar volume for gases at stp = 22.4 dm<sup>3</sup>

---

**Directions to Candidates**

- Write your index number in the space at the top left-hand corner of this page.
  - Answer **ALL** questions in Section A.
  - Answer **TWO** questions from Section B.
  - Write all your answers in the spaces provided in this booklet.
  - The mark allocation is indicated at the end of each question. Marks allocated to parts of questions are also indicated in brackets.
  - You are reminded of the necessity for orderly presentation in your answers.
  - In calculations you are advised to show all the steps in your working, giving your answer at each stage.
  - The use of electronic calculators is permitted.
  - A Periodic Table is printed on the back of this booklet.
- 

**For examiners' use only:**

Question	1	2	3	4	5	6	7	8	9	10	11	12	13	14	Total
Score															
Maximum	6	6	6	6	6	6	6	6	6	6	20	20	20	20	100

**SECTION A**

**Answer ALL questions in this Section. Write your answers in the spaces provided.**

1. The blast furnace is an industrial process that produces iron on a large scale. Using the words and phrases in the table below, label the diagram of the blast furnace.

molten iron	compressed hot air	haematite
limestone	molten slag	waste hot air

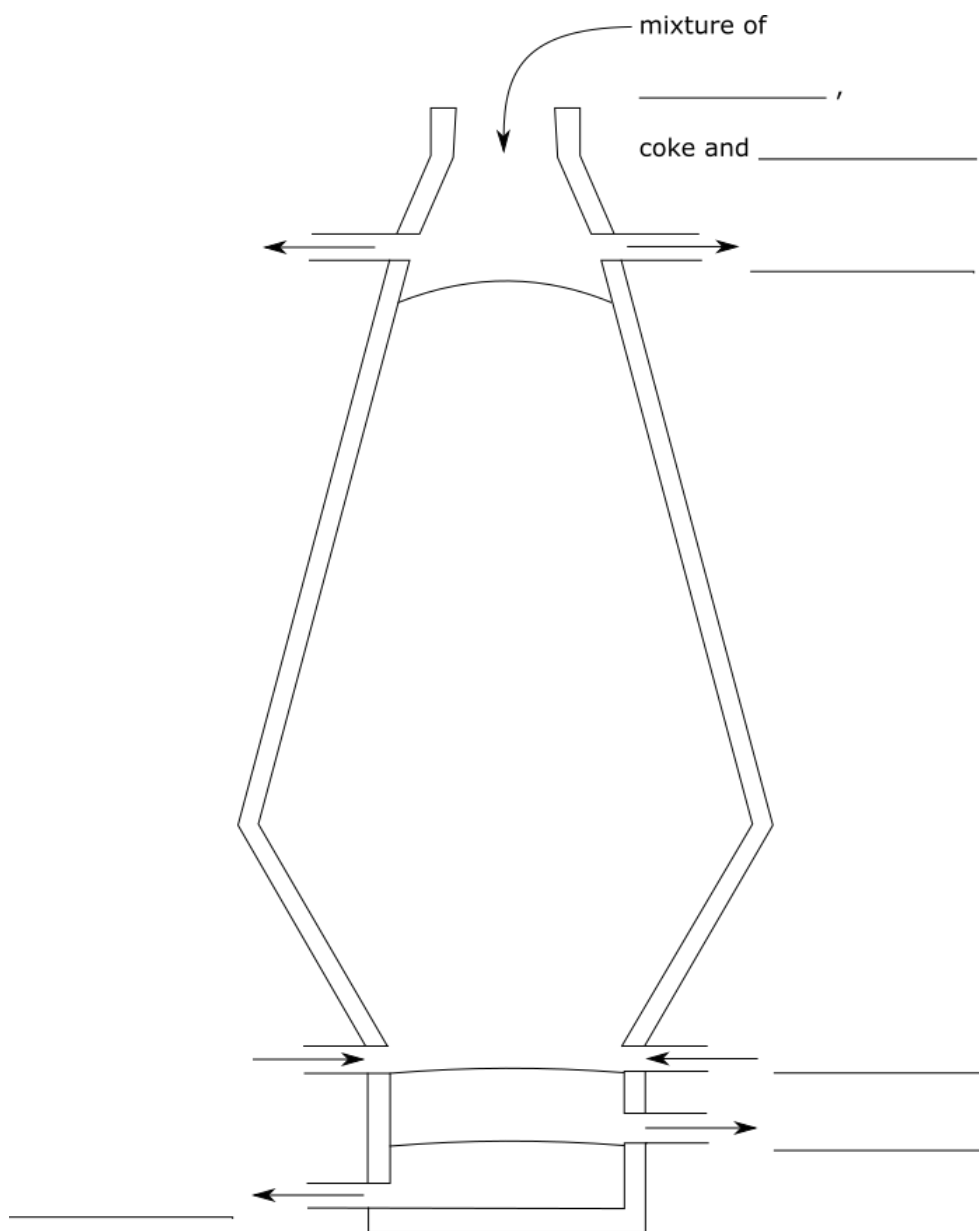

6

**(Total: 6 marks)**

2. Oxygen is prepared in the laboratory by the catalytic decomposition of hydrogen peroxide.

(a) Name the catalyst that is used in this reaction.

\_\_\_\_\_ (1)

(b) What is the function of the catalyst?

\_\_\_\_\_ (1)

(c) Write a balanced chemical equation for this reaction.

\_\_\_\_\_ (2)

(d) Give **ONE** physical property of oxygen gas.

\_\_\_\_\_ (1)

(e) Describe a test for oxygen and state the result expected.

\_\_\_\_\_ (1)

(Total: 6 marks)

6

3. Whitewashers use a mixture of slaked lime,  $\text{Ca(OH)}_2$ , and water to paint stone walls. They buy quick lime,  $\text{CaO}$ , from hardware stores who in turn get their quick lime from manufacturers. These manufacturers operate lime kilns in which limestone,  $\text{CaCO}_3$ , is converted to quick lime.

(a) Write a balanced chemical equation for the conversion of limestone to quicklime.

\_\_\_\_\_ (2)

(b) What is needed to convert limestone to quick lime?

\_\_\_\_\_ (1)

(c) When whitewashers mix quicklime with water, they know that they must be very careful when handling the mixture. Name **ONE** precaution that whitewashers should take.

\_\_\_\_\_ (1)

(d) Slaked lime,  $\text{Ca(OH)}_2$ , turns from colourless to white through a reaction with carbon dioxide found in air. Write a balanced chemical equation for this reaction.

\_\_\_\_\_ (2)

(Total: 6 marks)

6

4. Name the gases in the tests below:

(a) A colourless, odourless, non-toxic gas which extinguishes a lighted splint.

\_\_\_\_\_ (1)

(b) A gas which burns with a pop in the presence of a lighted splint.

\_\_\_\_\_ (1)

(c) A gas which turns moist red litmus paper to blue.

\_\_\_\_\_ (1)

(d) A gas which turns acidified potassium dichromate solution from orange to green.

\_\_\_\_\_ (1)

(e) A gas which reacts with ammonia to form a white solid.

\_\_\_\_\_ (1)

(f) A brown gas which turns moist blue litmus paper to red.

\_\_\_\_\_ (1)

**(Total: 6 marks)**

6

5. Acids are a class of compounds that react with bases.

(a) Define the term 'acid'.

\_\_\_\_\_ (1)

(b) Define the term 'base'.

\_\_\_\_\_ (1)

(c) What happens to the temperature of an acidic solution when it reacts with a base?

\_\_\_\_\_ (1)



(d) When acids react with bases, they produce salts. For the following combinations of acids and bases, name the salt that would be produced in each case.

(i) Hydrochloric acid and potassium hydroxide: \_\_\_\_\_ (1)

(ii) Sulfuric acid and ammonia solution: \_\_\_\_\_ (1)

(e) What is the name given to the reaction that happens between acids and bases?  
 \_\_\_\_\_ (1)

**(Total: 6 marks)**

6

6. The reactivity of the halogens can be investigated by using displacement reactions. These reactions involve solutions of halide salts that are mixed with different halogen elements.

(a) Join lines between the solutions on the left with the halogens on the right to show which combinations would result in a chemical reaction.

NaI (aq)

Br<sub>2</sub> (l)

NaCl (aq)

I<sub>2</sub> (s)

NaBr (aq)

Cl<sub>2</sub> (g)

(1)

(b) Write a balanced ionic equation for **ONE** of the reactions.

\_\_\_\_\_ (2)

(c) From the reaction you chose in part (b), which substance was:

(i) reduced; \_\_\_\_\_ (1)

(ii) oxidised. \_\_\_\_\_ (1)

(d) What is the oxidation number of the iodide ion in sodium iodide?  
 \_\_\_\_\_ (1)

**(Total: 6 marks)**

6

*Please turn the page.*

7. A student neutralized  $25.0 \text{ cm}^3$  of  $0.2 \text{ mol dm}^{-3}$  of sodium carbonate solution with hydrochloric acid. The student carried out the experiment three times and obtained the following results.

	Experiment 1	Experiment 2	Experiment 3
Volume of acid used	$10.60 \text{ cm}^3$	$10.05 \text{ cm}^3$	$9.95 \text{ cm}^3$

- (a) The student calculated the volume of acid used by taking the average of the volume of acid used in Experiment 2 and Experiment 3. Explain why the first reading was **not** considered.

\_\_\_\_\_ (1)

- (b) Calculate the amount (moles) of  $0.2 \text{ mol dm}^{-3}$  sodium carbonate in the  $25.0 \text{ cm}^3$  sample which was neutralised by the hydrochloric acid.

\_\_\_\_\_ (1)

- (c) How many moles of hydrochloric acid, HCl, react with 1 mole of sodium carbonate,  $\text{Na}_2\text{CO}_3$ ?

\_\_\_\_\_ (1)

- (d) What amount (moles) of hydrochloric acid took part in this reaction?

\_\_\_\_\_ (1)

- (e) Calculate the concentration of the hydrochloric acid used in this reaction in  $\text{mol dm}^{-3}$ .

\_\_\_\_\_ (2)

(Total: 6 marks)

6

8. The structural formula of the polymer polyethene is shown below.

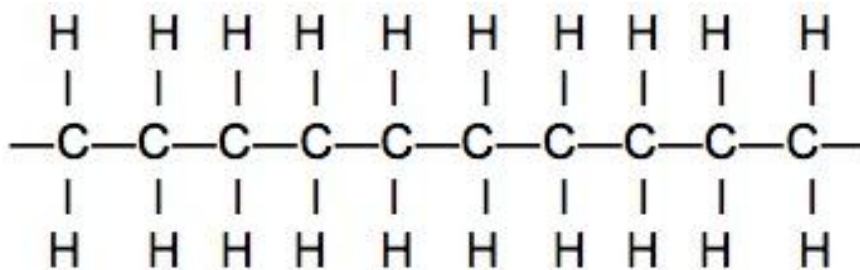

(a) Define the term ‘polymer’.

\_\_\_\_\_ (1)

(b) Why does the structural formula of polyethene has a free bond at each end?

\_\_\_\_\_ (1)

(c)

(i) Write the structural formula of the monomer from which polyethene is made.

\_\_\_\_\_ (1)

(ii) What is the state in which the monomer is found at room temperature and atmospheric pressure?

\_\_\_\_\_ (1)

(iii) What is the state in which polyethene is found at room temperature and atmospheric pressure?

\_\_\_\_\_ (1)

(d) Give **ONE** use of polyethene.

\_\_\_\_\_ (1)

(Total: 6 marks)

6

*Please turn the page.*

9. A student performed tests on three unknown substances. Identify these substances from the student's observations:

- (a) Substance **A** was a green powder which turned black when heated strongly. The remaining black powder reacted with dilute hydrochloric acid and produced a blue solution.

The green powder reacted with effervescence when mixed with dilute hydrochloric acid.

Substance **A** was \_\_\_\_\_ (2)

- (b) Substance **B** was a white crystalline substance which dissolved readily in water. On performing a flame test, a brilliant yellow flame was seen.

When a few drops of acidified silver nitrate were added to the remaining solution, a white precipitate was obtained which darkened in the presence of sunlight.

Substance **B** was \_\_\_\_\_ (2)

- (c) Substance **C** was a white powder which dissolved in water to produce a clear solution. When a few drops of sodium hydroxide solution were added to a sample of this solution, a white precipitate was seen. On adding more sodium hydroxide solution to this precipitate, the precipitate dissolved to form a clear solution. On addition of a few drops of potassium iodide to the original clear solution, a yellow precipitate was produced.

When substance **C** was heated gently in a solution of sodium hydroxide and then some aluminium powder was added, ammonia was produced.

Substance **C** was \_\_\_\_\_ (2)

(Total: 6 marks)

6

10.

- (a) A hydrocarbon is made up of 85.71 % carbon and 14.29 % hydrogen. Work out the empirical formula of this substance.

---

---

---

---

---

---

---

---

---

---

(3)

- (b) If the relative molecular mass of this substance is 42, find the molecular formula of this hydrocarbon.

---

---

(2)

- (c) Draw the structural formula of this hydrocarbon.

(1)

6

**(Total: 6 marks)***Please turn the page.*

**SECTION B**

Answer **TWO** questions from this section. Write your answers in the lined pages provided. Clearly indicate the question numbers being answered.

11. Chlorine may be prepared in the laboratory by the action of concentrated hydrochloric acid on manganese(IV) oxide according to the equation



- (a) Give **TWO** tests, which may be physical or chemical, to show that chlorine is produced in the reaction. (2)
- (b) Give **TWO** methods for collecting the chlorine gas. Explain why one of the two methods is better than the other. (3)
- (c) In this reaction, is  $\text{MnO}_2$  acting as a catalyst or an oxidising agent? Explain. (2)
- (d) Starting with 73.0 g of HCl dissolved in water, calculate the number of moles of chlorine that will be formed in the reaction. (4)
- (e) Consider the following unbalanced equations that show the unknown substances **X** and **Y**.

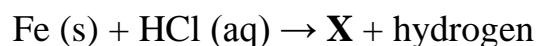

- (i) Give the names or formulae of substances **X** and **Y**. (2)
- (ii) Give **ONE** chemical test that can distinguish between solutions of **X** and **Y**. Give also the expected observations. (3)
- (iii) Why does iron give different products when it reacts separately with hydrochloric acid and with chlorine? (1)
- (f)
- (i) 'Unlike iron, when magnesium reacts separately with hydrochloric acid and with chlorine the same product is obtained'. Explain this statement. (1)
- (ii) Is the reaction of iron powder with dilute hydrochloric acid more or less vigorous than the reaction of magnesium powder with the same hydrochloric acid? Explain your answer. (2)

**(Total: 20 marks)**

12. Ethanol,  $C_2H_6O$ , is a flammable substance. When it burns, it produces carbon dioxide, water vapour, and heat energy. The theoretical change in heat of combustion of ethanol is  $-1360 \text{ kJ mol}^{-1}$ .

- (a) Write a balanced chemical equation, including state symbols, for the combustion of ethanol. (3)
- (b) Describe, in terms of bonds and energy requirements, what happens during the combustion of ethanol. (4)
- (c) During an investigation, a student heated some water in a copper can using a spirit lamp filled with ethanol. To find the change in heat of combustion of ethanol, the student measured the following results:
- mass of ethanol burned: 3 g;
  - mass of water: 100 g;
  - change in temperature of water:  $48 \text{ }^\circ\text{C}$ .

Calculate:

- (i) the RMM of ethanol; (1)
- (ii) the amount (moles) of ethanol used in this experiment; (1)
- (iii) the energy absorbed by the water given that the value of the specific heat capacity of water is  $4.18 \text{ J g}^{-1} \text{ }^\circ\text{C}^{-1}$ ; (1)
- (iv) the change in heat (enthalpy) of combustion per mole of ethanol, using your answers to parts (c)(i) and (c)(iii). (1)
- (d) Compare the change in heat of combustion obtained in part (c)(iv) with the theoretical value of  $-1360 \text{ kJ mol}^{-1}$ .
- (i) Give **TWO** reasons why these values are so different from each other. (2)
- (ii) Using your answer to part (c), calculate the percentage accuracy of the experiment. (1)

(e) Ethanol can be prepared by the hydration of ethene obtained either from the cracking of long chain alkanes or by fermentation, as shown in the following diagram.

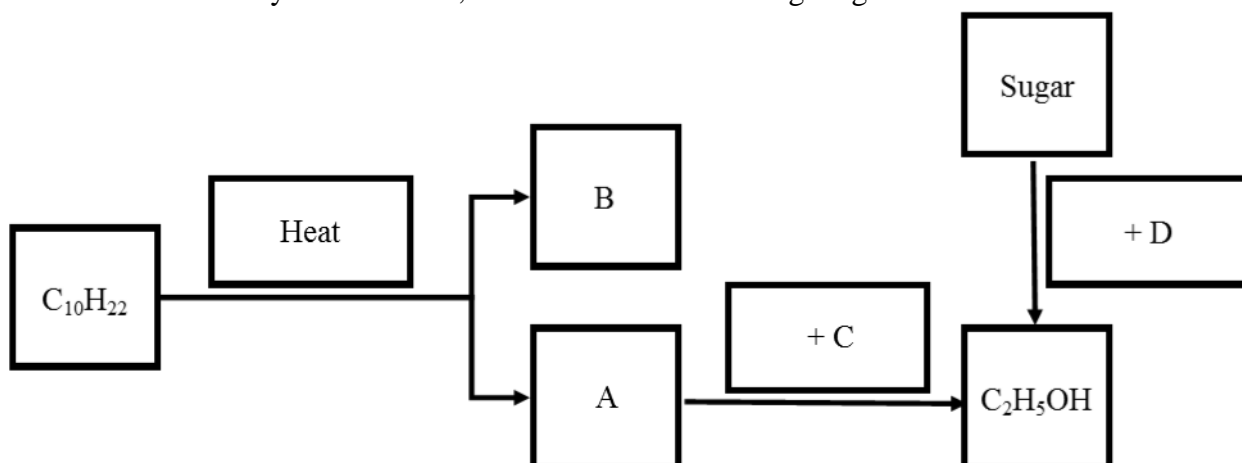

- (i) Label substances **A** to **D**. (4)
- (ii) Which **ONE** of the organic substances in the above schematic diagram is unsaturated? Explain your answer. (2)

**(Total: 20 marks)**

13. Carbon dioxide is a gas which is found naturally in the atmosphere. However, due to burning of fossil fuels, its concentration in air has been increasing since the industrial revolution.

(a) Describe briefly how carbon dioxide can be produced and collected in a gas jar in the laboratory using limestone chips and hydrochloric acid. Your description should include:

- (i) a labelled diagram of the apparatus used in the laboratory; (4)
- (ii) the steps needed to prepare carbon dioxide and collect it in a gas jar; (4)
- (iii) a balanced chemical equation, including state symbols, for the reaction taking place. (3)

(b) Many gases including carbon dioxide and methane are greenhouse gases. Methane is a more powerful greenhouse gas than carbon dioxide. These greenhouse gases contribute towards global warming.

- (i) What is a greenhouse gas? (1)
- (ii) Why is carbon dioxide given most of the blame for global warming? (1)

(c) Cars are fitted with catalytic converters which convert carbon monoxide to carbon dioxide.

- (i) Why is carbon monoxide converted to carbon dioxide? (1)
- (ii) Name **ONE** other pollutant gas the presence of which is reduced by a catalytic converter. (1)

(d) A large amount of carbon dioxide dissolves in sea water. The solubility curve for carbon dioxide is shown below.

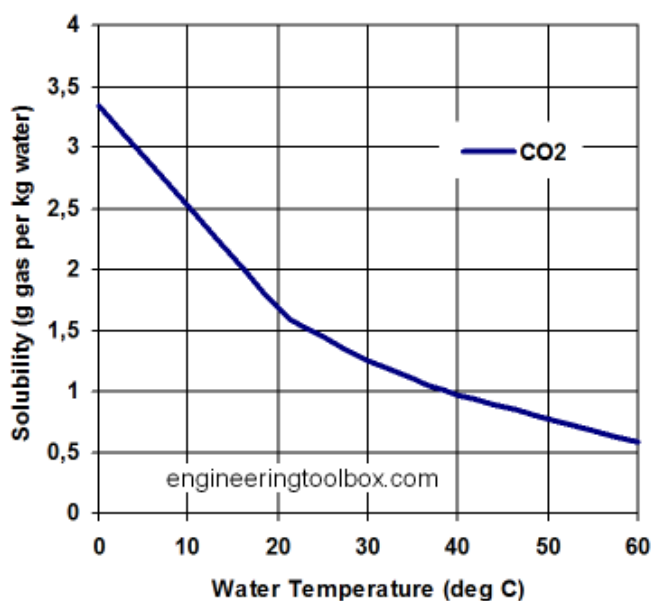

- (i) Estimate the solubility of carbon dioxide in water at 10 °C. (1)
- (ii) Name the product formed when carbon dioxide reacts with water. (1)
- (iii) What happens to the pH of sea water when carbon dioxide dissolves in it? (1)
- (iv) Scientists are afraid that higher levels of global warming will cause changes in the amount of carbon dioxide dissolved in the oceans which will, in turn, have an effect on global warming. Use the figure above to explain this hypothesis. (2)

**(Total: 20 marks)**



14. The Contact process for the manufacture of sulfuric acid involves a series of steps. Two of the reactions are the following:

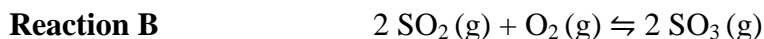

- (a) In **Reaction A**, sulfur is converted into sulfur dioxide.
- (i) From the equation, what is the mole ratio between sulfur and sulfur dioxide? (1)
  - (ii) If a mass of 40.0 g of sulfur is used, calculate the amount (moles) of sulfur used. (2)
  - (iii) From your answers to parts (i) and (ii), calculate the mass of sulfur dioxide produced in the reaction. (3)
- (b) **Reaction B** shows how sulfur dioxide is converted into sulfur trioxide. A catalyst is needed for this part of the process.
- (i) Name the catalyst normally used in this reaction. (1)
  - (ii) Besides using a catalyst, give **TWO** ways to ensure a high rate of reaction for **Reaction B**. (2)
- (c) **Reaction B** sets up an equilibrium in which the forward reaction gives out heat.
- (i) What is the effect on the position of equilibrium when a catalyst is used in the process? (1)
  - (ii) In which direction will the equilibrium shift if the temperature is lowered? Explain your answer. (2)
- (d) The sulfur trioxide produced in **Reaction B** is **not** added directly to water to produce sulfuric acid. Give **TWO** equations to show how sulfur trioxide is converted into sulfuric acid. (4)
- (e) Sulfuric acid has several uses in chemistry.
- (i) Give the names or formulae of the products when concentrated sulfuric acid reacts with glucose,  $C_6H_{12}O_6$ . (2)
  - (ii) What property of sulfuric acid is shown by the reaction in part (e)(i)? (1)
  - (iii) In some gas preparations, before the gas is collected, the gas required is first allowed to pass through a flask which contains concentrated sulfuric acid. What is the purpose of using concentrated sulfuric acid in such experiments? (1)

**(Total: 20 marks)**

*Please turn the page.*







DO NOT WRITE ABOVE THIS LINE

---

---

---

---

---

---

---

---

---

---

---

---

---

---

---

---

---

---

---

---

---

---

---

---

---

---

---

---

---

---





**PERIODIC TABLE**

I	II	III	IV	V	VI	VII	VIII
---	----	-----	----	---	----	-----	------

1		2					4
7	9	11	12	14	16	19	20
Li	Be	B	C	N	O	F	Ne
3	4	5	6	7	8	9	10
23	24	27	28	31	32	35.5	40
Na	Mg	Al	Si	P	S	Cl	Ar
11	12	13	14	15	16	17	18
39	40	70	73	75	79	80	84
K	Ca	Ga	Ge	As	Se	Br	Kr
19	20	31	32	33	34	35	36
85	88	115	119	122	128	127	131
Rb	Sr	In	Sn	Sb	Te	I	Xe
37	38	49	50	51	52	53	54
133	137	204	207	209	209	210	222
Cs	Ba	Tl	Pb	Bi	Po	At	Rn
55	56	81	82	83	84	85	86
223	226	81	82	83	84	85	86
Fr	Ra	Tl	Pb	Bi	Po	At	Rn
87	88	81	82	83	84	85	86

140	141	144	147	150	152	157	159	162	165	167	169	173	175
Ce	Pr	Nd	Pm	Sm	Eu	Gd	Tb	Dy	Ho	Er	Tm	Yb	Lu
58	59	60	61	62	63	64	65	66	67	68	69	70	71
232	231	238	237	244	243	247	247	251	252	257	258	259	260
Th	Pa	U	Np	Pu	Am	Cm	Bk	Cf	Es	Fm	Md	No	Lr
90	91	92	93	94	95	96	97	98	99	100	101	102	103

Relative atomic mass

—	A
X	X
Z	Z

Atomic Number

—	Z
---	---

Key