



L-Università  
ta' Malta

MATRICULATION AND SECONDARY EDUCATION  
CERTIFICATE EXAMINATIONS BOARD

**SECONDARY EDUCATION CERTIFICATE LEVEL  
2023 SUPPLEMENTARY SESSION**

SUBJECT: **Mathematics**  
DATE: 2<sup>nd</sup> September 2023

PAPER: I – Section A (Non-Calculator Section)  
TIME: 20 minutes

Attempt **ALL** questions.

Write your answers in the space available on the examination paper.

The use of calculators and protractors is **not** allowed.

It is not necessary to show your working.

This paper carries a total of 20 marks.

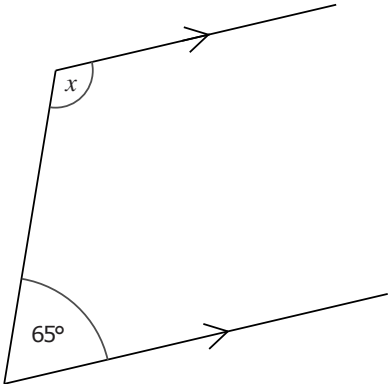
<p style="text-align: center;"><b>QUESTIONS AND ANSWERS</b> <b>ALL QUESTIONS CARRY ONE MARK</b></p>	<p style="text-align: center;"><b>SPACE FOR ROUGH WORK (IF NECESSARY)</b></p>
<p>1 Put these numbers in order, starting from the smallest:</p> <p style="text-align: center;">0.229, 0.1119, 0.3</p> <p style="text-align: center;"><b>Ans</b> _____</p>	
<p>2 Work out the size of the angle marked <math>x</math>.</p> <div style="text-align: center;">  <p style="text-align: right;"><i>Diagram not drawn to scale</i></p> </div> <p style="text-align: center;"><b>Ans</b> _____</p>	
<p>3 How many cubic centimetres are there in <math>3\frac{1}{2}</math> litres?</p> <p style="text-align: center;"><b>Ans</b> _____</p>	

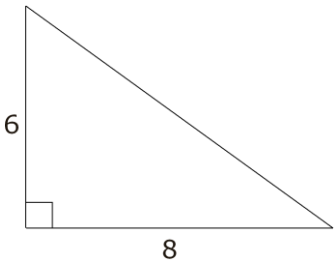
<p style="text-align: center;"><b>QUESTIONS AND ANSWERS</b> <b>ALL QUESTIONS CARRY ONE MARK</b></p>	<p style="text-align: center;"><b>SPACE FOR ROUGH WORK (IF NECESSARY)</b></p>
<p>4 A room is drawn on a map with scale of 1:50. The width of the room on the map is 7 cm. What is the width of the room in metres?</p> <p style="text-align: right;"><b>Ans</b> _____</p>	
<p>5 Stef is facing North. She turns clockwise by one and a half right angles. In which direction is she facing?</p> <p style="text-align: right;"><b>Ans</b> _____</p>	
<p>6 What is the size of the hypotenuse of this right-angled triangle?</p> <div style="display: flex; align-items: center; justify-content: center;">  <div style="margin-left: 20px;"> <p><i>Diagram not drawn to scale</i></p> </div> </div> <p style="text-align: right;"><b>Ans</b> _____</p>	
<p>7 Work out: <math>\frac{3}{7} + \frac{1}{14}</math></p> <p style="text-align: right;"><b>Ans</b> _____</p>	
<p>8 Sandra bought 50 biros for €115. What is the cost of one biro?</p> <p style="text-align: right;"><b>Ans</b> _____</p>	
<p>9 A regular polygon has 12 sides. What is the size of its exterior angles?</p> <p style="text-align: right;"><b>Ans</b> _____</p>	
<p>10 What is the value of <math>x</math> when: <math>3^x = 81</math></p> <p style="text-align: right;"><b>Ans</b> _____</p>	

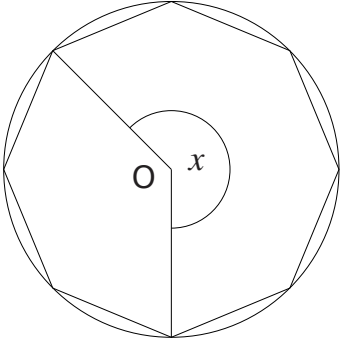
<p style="text-align: center;"><b>QUESTIONS AND ANSWERS</b> <b>ALL QUESTIONS CARRY ONE MARK</b></p>	<p style="text-align: center;"><b>SPACE FOR ROUGH WORK (IF NECESSARY)</b></p>
<p>11 The figure shows a regular octagon inscribed in a circle centre O. What is the size of the reflex angle at O, marked <math>x</math>?</p>  <p style="text-align: right;"><b>Ans</b> _____</p>	
<p>12 The volume of a cube is <math>27000 \text{ cm}^3</math>. What is the length of its sides?</p> <p style="text-align: right;"><b>Ans</b> _____</p>	
<p>13 The probability that a particular type of bulb is defective is 0.014. How many defective bulbs are expected to be found in a batch of 500 of these bulbs?</p> <p style="text-align: right;"><b>Ans</b> _____</p>	
<p>14 Elaine thinks of a number. She multiplies this number by 3, then adds 4. Her result is 55. What number did Elaine start with?</p> <p style="text-align: right;"><b>Ans</b> _____</p>	
<p>15 The mean mark of a class of 19 students is 60 marks. What is the total sum of the student marks?</p> <p style="text-align: right;"><b>Ans</b> _____</p>	

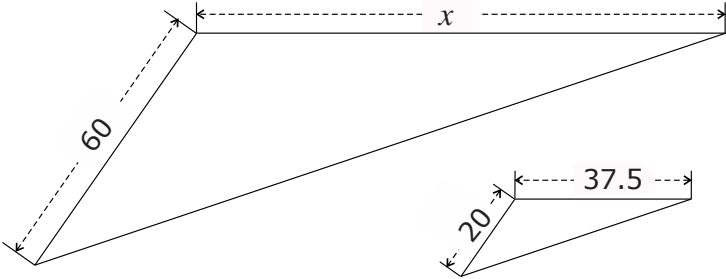
<p style="text-align: center;"><b>QUESTIONS AND ANSWERS</b> <b>ALL QUESTIONS CARRY ONE MARK</b></p>	<p style="text-align: center;"><b>SPACE FOR ROUGH WORK</b> <b>(IF NECESSARY)</b></p>
<p>16 Simplify <math>3(a - 2b) - (a - b)</math></p> <p style="text-align: right;"><b>Ans</b> _____</p>	
<p>17 Four workmen dig a trench in twelve days. How long does it take three workmen to dig the same trench? Assume that all the workmen work at the same rate.</p> <p style="text-align: right;"><b>Ans</b> _____</p>	
<p>18 The two triangles are similar. Work out the value of <math>x</math>.</p>  <p style="text-align: center;"><i>Diagram not drawn to scale</i></p> <p style="text-align: right;"><b>Ans</b> _____</p>	
<p>19 Four consecutive numbers add up to 410. Which are the <b>FOUR</b> numbers?</p> <p style="text-align: right;"><b>Ans</b> _____</p>	
<p>20 Work out the value of:</p> $\frac{70 + 3 \times 11}{7 + 3}$ <p style="text-align: right;"><b>Ans</b> _____</p>	



L-Università  
ta' Malta

MATRICULATION AND SECONDARY EDUCATION CERTIFICATE  
EXAMINATIONS BOARD

**SECONDARY EDUCATION CERTIFICATE LEVEL  
2023 SUPPLEMENTARY SESSION**

---

SUBJECT: **Mathematics**  
 PAPER NUMBER: I – Section B (Calculator Section)  
 DATE: 2<sup>nd</sup> September 2023  
 TIME: 1hr and 45 minutes

---

Answer **ALL** questions.

Write your answers in the space available on the examination paper.

Show clearly all the necessary steps, explanations and construction lines in your working.

Unless otherwise stated, diagrams are drawn to scale.

The use of non-programmable electronic calculators with statistical functions and of mathematical instruments is allowed.

Candidates are allowed to use transparencies for drawing transformations.

This paper carries a total of 80 marks.

***For Office Use Only***

<b>Sec A</b>	<b>Sec B</b>											<b>Total</b>
	<b>1</b>	<b>2</b>	<b>3</b>	<b>4</b>	<b>5</b>	<b>6</b>	<b>7</b>	<b>8</b>	<b>9</b>	<b>10</b>	<b>11</b>	

- 
- 1 (a) Write down the number 30 303 in words. (1)
- (b) Write down **all** the factors of 44. (2)
- (c) Write down a prime number between 14 and 20. (1)
- (d) Write down 3.2% as a fraction in its lowest terms. (2)
- (e) Write the number 9 833 949 to the nearest thousand. (1)

**(Total: 7 marks)**

- 
- 2 A village club is organising a fund raising lottery.  
The draw prizes and their values are given below:
- A statue costing €72  
Two food hampers each costing €19  
Three bottles of wine each costing €4.50
- The tickets cost 50c each.
- (a) Calculate the total cost of the prizes. (3)
- (b) How many tickets need to be sold in order to just cover the cost of the prizes? (1)
- (c) How many tickets need to be sold to make a profit of €200? (2)

**(Total: 6 marks)**

- 3 The two pie charts below show how Pawlu and Chiara spent their stipends in the month of December.

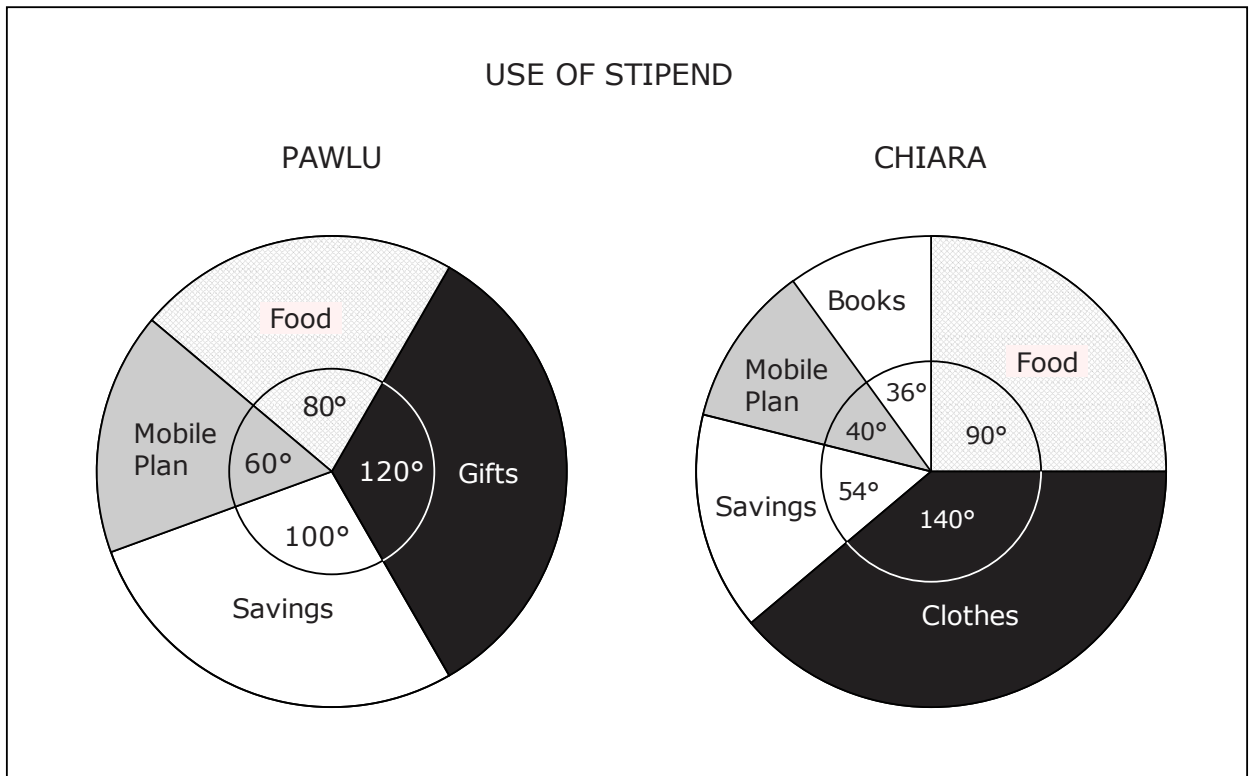

Pawlu and Chiara have the same stipend of €90.

- (a) How much did Pawlu spend on gifts? (2)
- (b) How much did Chiara spend on clothes? (2)
- (c) What percentage of her stipend did Chiara spend on books? (1)
- (d) Express as a ratio in its simplest form the amount Pawlu spent on his mobile plan to the amount Chiara spent on her mobile plan. (2)

(2)

**(Total: 7 marks)**

- 4 (a) The graph below shows the population of a sample of bacteria over time. Each bacterium of this particular species splits into 2 bacteria every hour. In the sample, there was just 1 bacterium at  $t = 0$ . There were 2 bacteria at  $t = 1$  hr, there were 4 bacteria at  $t = 2$  hr, and so on. Use the graph to answer the following:

(i) How many hours had passed when the number of bacteria was approximately 1000? (1)

(ii) Give an estimate of the number of bacteria after 8 hours. (1)

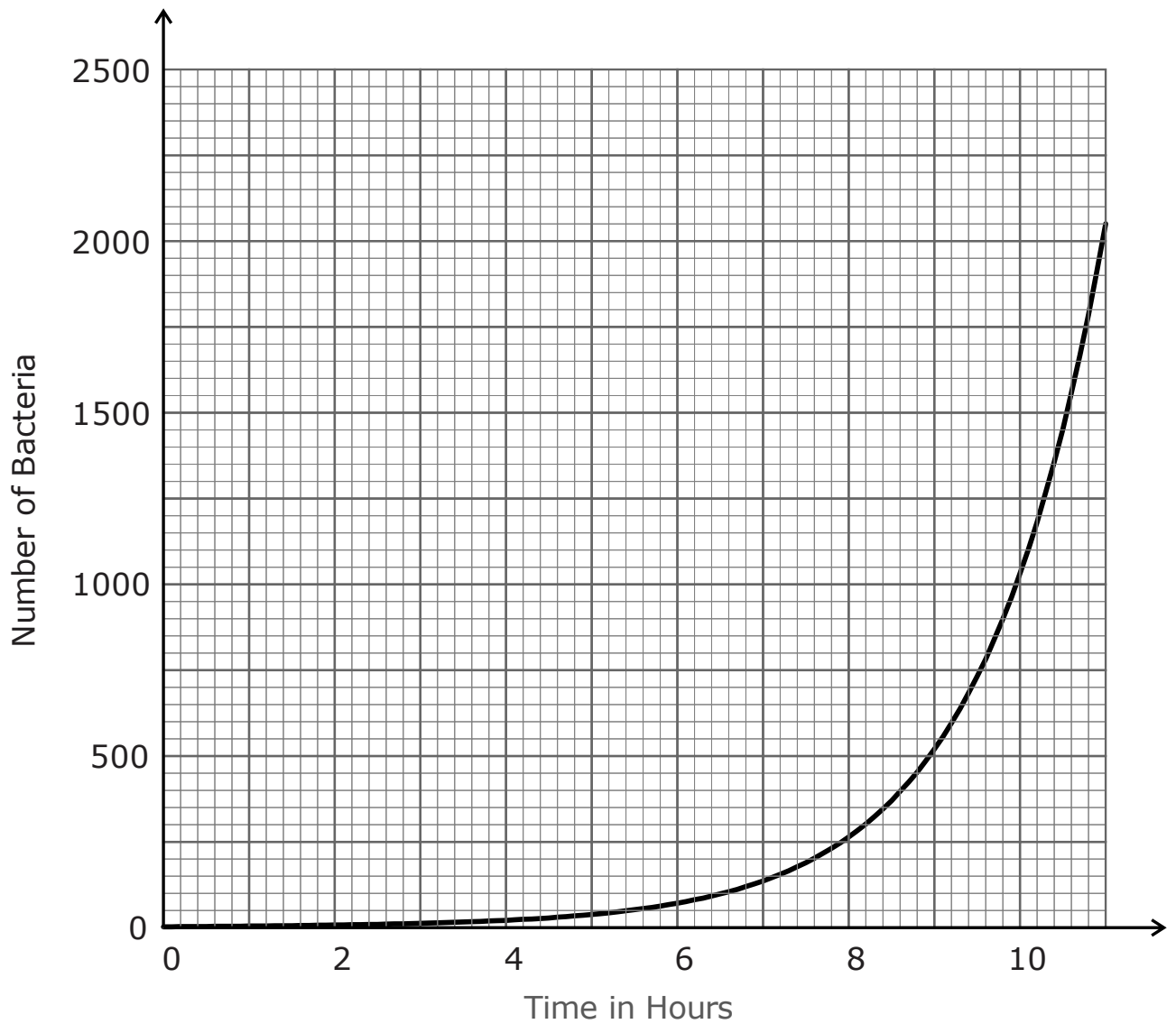



- (b) The population in this sample of bacteria can be represented by the equation  $N = 2^t$  where  $N$  is the population of bacteria at a particular time  $t$  (in hours).

Use this formula given above to answer the following:

- (i) Find the number of hours that had passed when the number of bacteria was 64. (2)
- (ii) Find the number of bacteria after 20 hours, giving your answer in standard form correct to three significant figures. (3)

**(Total: 7 marks)**

5 The table below shows:

- the areas of the islands of Malta and Gozo;
- the population of Malta and Gozo according to the population census taken in 2011 and 2021.

Island	Area in km <sup>2</sup>	Population Census 2011	Population Census 2021
Gozo	67	31,375	39,287
Malta	246	386,057	480,275

- (a) Work out the population of Gozo as a percentage of the total population of Malta and Gozo in 2021. (2)
- (b) Work out the average population per km<sup>2</sup> for the island of Gozo in 2021. (2)
- (c) What was the percentage increase in the total population of the Maltese islands between 2011 and 2021? (3)

**(Total: 7 marks)**

- 
- 6 (a) Anton's house is 1.3 km from the supermarket. He takes 5 minutes to cycle from home to the supermarket.  
Work out Anton's average cycling speed in km/h on this journey.

(3)

- (b) An airplane is travelling at a speed of 800 km/h.  
How long does it take to travel 150 km at this speed?  
Give your answer in minutes and seconds.

(4)

**(Total: 7 marks)**

- 
- 7 Use the axes on the next page to answer this question.
- (a) Translate shape X by  $\begin{pmatrix} -7 \\ -5 \end{pmatrix}$ . Label the image shape A. (2)
- (b) Reflect shape X in the  $x$  axis. Label the image shape B. (2)
- (c) Reflect shape B in the  $y$  axis. Label the image shape C. (2)
- (d) Describe the transformation which maps shape A onto shape X. (2)
- (e) Describe the transformation which maps shape C onto shape X. (2)

(2)

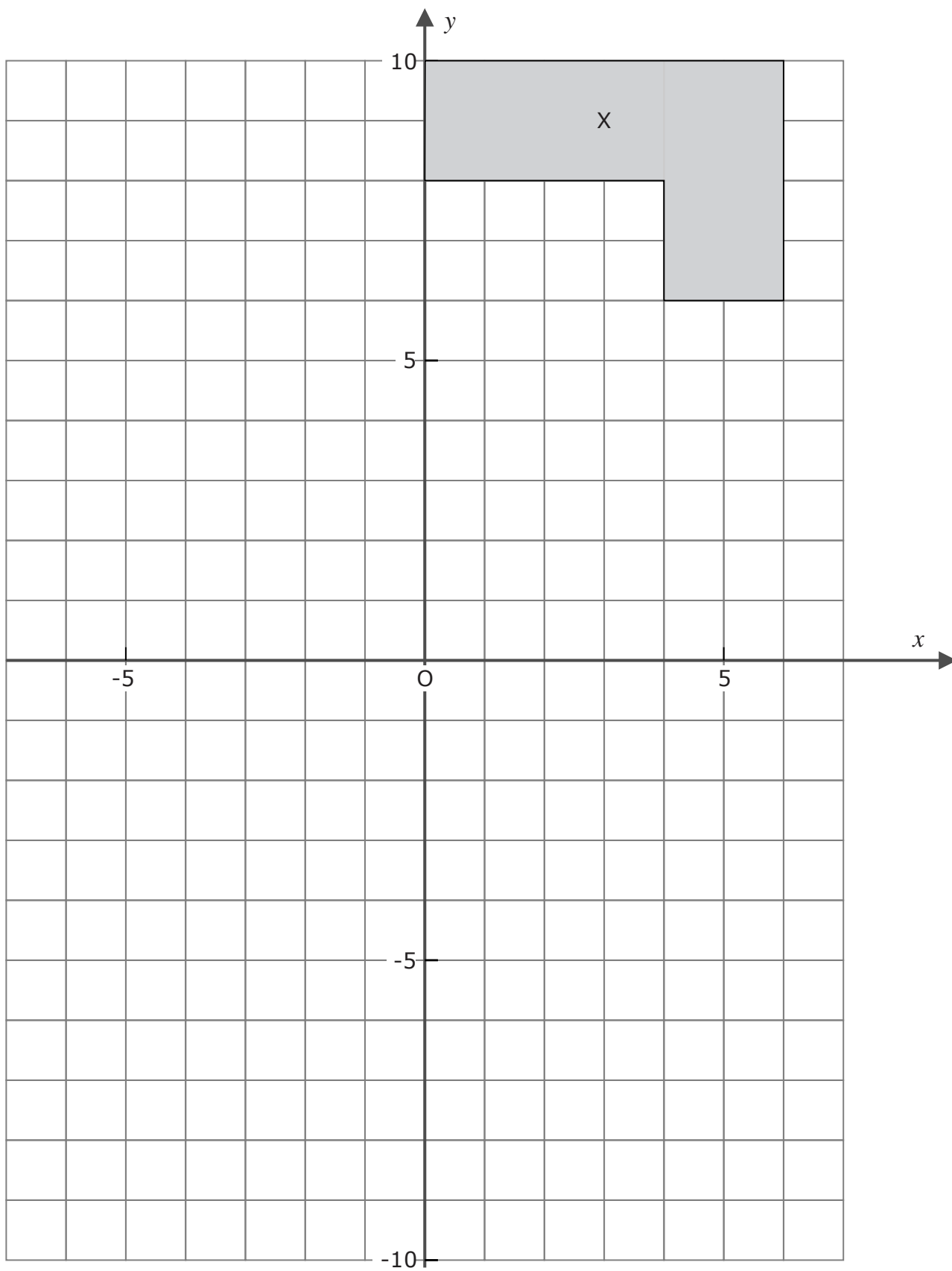

**(Total: 10 marks)**

- 
- 8 Last week a baker used 5 kg of pistachios in one of her desserts.  
With this quantity of pistachio, she made three batches of 75 pastries.

Next week, the baker plans to make the same dessert in batches of 30 pastries.  
How many batches of 30 pastries will she be able to make with 4 kg of pistachio?

---

**(Total: 4 marks)**

- 9 (a) Factorise:

(i)  $24x - 6$

(1)

(ii)  $12x^2 - 3x$

(2)

- (b) Hence show that:  $\frac{12x^2-3x}{24x-6} = \frac{x}{2}$

(2)

- (c) Use part (b) to express as a single fraction:  $\frac{12x^2-3x}{24x-6} - \frac{x-1}{5}$

(4)

---

**(Total: 9 marks)**

- 10 Use the dimensions given in the figure to calculate the height  $H$  of this flight of stairs. Give your answer to the nearest cm.

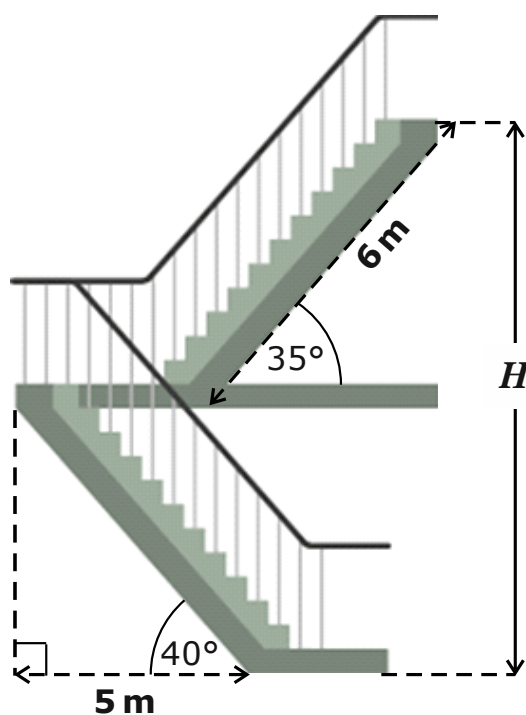

*Diagram not drawn to scale*

**(Total: 7 marks)**

11

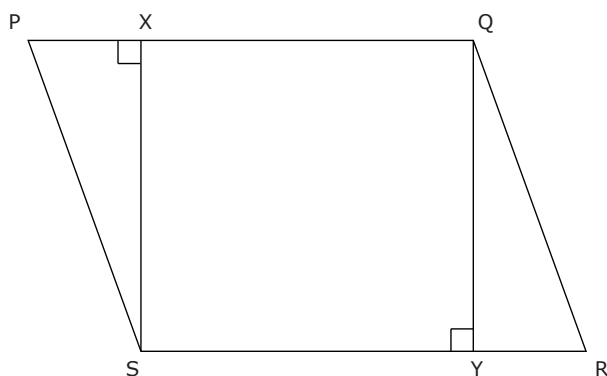
*Diagram not drawn to scale*

In the figure above, PQRS is a parallelogram.  
XS and QY are perpendicular to PQ and RS respectively.

(a) Show that  $\triangle PXS$  and  $\triangle RYQ$  are congruent.

(4)

The area of  $\triangle PXS$  is  $20 \text{ cm}^2$  and  $PX$  is  $5 \text{ cm}$ .

(b) Show that the length of  $XS$  is  $8 \text{ cm}$ .

(2)

(c) The area of the parallelogram is  $120 \text{ cm}^2$ .  
Work out the length of  $SY$ .

(3)

**(Total: 9 marks)**

**Blank Page**

**Blank Page**





**L-Università  
ta' Malta**

MATRICULATION AND SECONDARY EDUCATION CERTIFICATE  
EXAMINATIONS BOARD

**SECONDARY EDUCATION CERTIFICATE LEVEL  
2023 SUPPLEMENTARY SESSION**

---

SUBJECT: **Mathematics**  
 PAPER NUMBER: IIB  
 DATE: 2<sup>nd</sup> September 2023  
 TIME: 4:00 p.m. to 6:05 p.m.

---

Answer **ALL** questions.

Write your answers in the space available on the examination paper.

Show clearly all the necessary steps, explanations and construction lines in your working.

Unless otherwise stated, diagrams are drawn to scale.

The use of non-programmable electronic calculators with statistical functions and of mathematical instruments is allowed.

Candidates are allowed to use transparencies for drawing transformations.

This paper carries a total of 100 marks.

***For Office Use Only***

<b>Question No</b>	<b>1</b>	<b>2</b>	<b>3</b>	<b>4</b>	<b>5</b>	<b>6</b>	<b>7</b>	<b>8</b>	<b>9</b>	<b>10</b>
<b>Mark</b>										

<b>Question No</b>	<b>11</b>	<b>12</b>	<b>13</b>	<b>14</b>	<b>15</b>	<b>16</b>	<b>17</b>	<b>18</b>	<b>19</b>	<b>20</b>	<b>21</b>
<b>Mark</b>											

**Total Mark**

- 1 The following table shows the number of cars sold per month by a company last year.

Month	Number of Cars Sold
January	42
February	21
March	31
April	26
May	36
June	31
July	42
August	30
September	36
October	45
November	42
December	46

- (a) In which month was the highest number of car sales recorded? (1)
- (b) Find the mean number of cars sold per month. (2)
- (c) Find the median number of cars sold per month. (2)
- (d) If a similar pattern of car sales is expected this year, what is the probability of selling more than 36 cars per month? (1)

**(Total: 6 marks)**

2 A shop is offering a promotion on one of its products. Originally a pack of 2 items could be bought for €15.24. With the promotion a pack of 3 items can be bought for the same price.

- (a) How much was the cost of each item before the promotion? (1)
- (b) How much is the cost of each item during the promotion? (1)
- (c) During the promotion, how many items can I buy for €50? (1)

(3)

**(Total: 5 marks)**

3

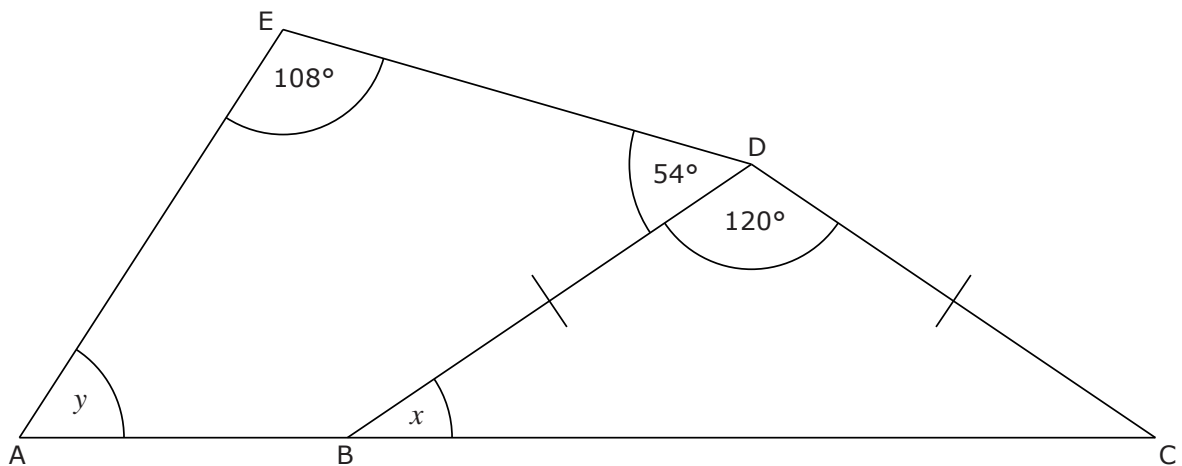

*Diagram not drawn to scale*

Use the information in the diagram above to work out the values of  $x$  and  $y$ .  
Explain your reasoning.

**(Total: 5 marks)**

- 4 A group of teenagers were asked about their home location. The results are shown in the table below.

Home Location	Boy	Girl
Senglea	4	5
Cospicua	6	8
Vittoriosa	4	6
Kalkara	3	4

- (a) How many teenagers were part of this survey? (1)
- (b) A teenager is chosen at random from this group. Work out the probability that the teenager is:
- (i) a boy living in Cospicua; (2)
- (ii) a girl who does **not** live in Kalkara. (2)

**(Total: 5 marks)**

- 5 If  $p = 4$ ,  $q = 10$ ,  $r = -5$  work out the values of:

- (a)  $3p + 4q$  (1)
- (b)  $3p - 4r$  (1)
- (c)  $3p + 4r$  (1)
- (d)  $r(p - q)$  (1)

**(Total: 5 marks)**

6 Fill in the empty boxes with the corresponding values on the number line.

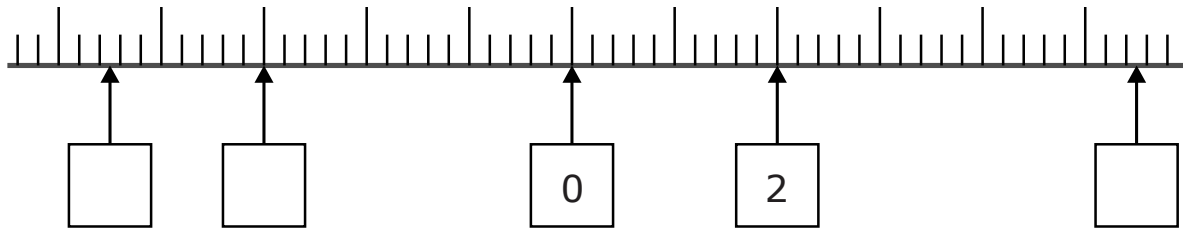

**(Total: 3 marks)**

7 A, B, C and D are points on the circumference of a circle centre O. AC passes through O and SCR is a tangent to the circle.

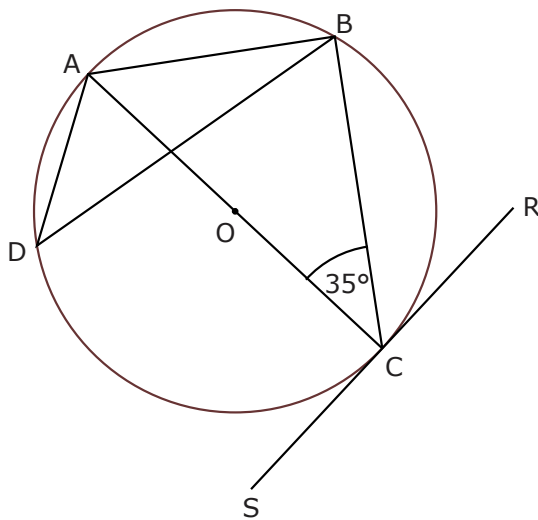

*Diagram not drawn to scale*

Determine the size of the following angles. Explain your answer in each case:

(a)  $\angle ABC$

(b)  $\angle ADB$

(c)  $\angle BCR$

(2)

(2)

(2)

**(Total: 6 marks)**

- 
- 8 Last year Juan made an investment of €35 000.  
After a year, the interest was added to his account.  
The amount after this transaction was €35 875.  
Calculate the interest rate per annum for Juan's investment.

**(Total: 3 marks)**

- 9 The table shows the population of three large countries and of the world.

Country	Population
China	$1.45 \times 10^9$
India	$1.42 \times 10^9$
Pakistan	$2.33 \times 10^8$

Answer the following questions giving your answers in standard form.

- (a) What is the total population of India and China?

(2)

- (b) How much larger is the population of China than that of India?

(2)

- (c) What is the total population of India and Pakistan?

(2)

**(Total: 6 marks)**

- 10 When a polygon is divided into triangles as shown below, the number of triangles formed is two less than the number of sides of the polygon.

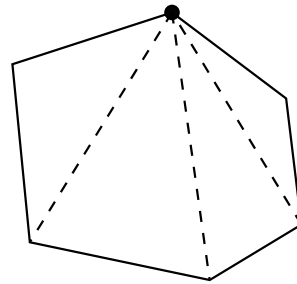

In the figure above, the polygon has 6 sides and 4 triangles are formed.

- (a) How many triangles are there for a polygon with 100 sides?

(1)

- (b) How many triangles are there for a polygon with  $n$  sides?

(1)

**(Total: 2 marks)**

- 11 Jill is travelling from New York to Malta via London.  
Her first flight leaves New York at 9:00pm on Friday and arrives in London at 9:20am on Saturday.  
Her second flight leaves London at 10:50am on Saturday and arrives in Malta at 3:00pm on Saturday.

Malta is ahead of New York by 6 hours and Malta is ahead of London by 1 hour.

- (a) How many hours is London ahead of New York?

(1)

- (b) How long did Jill's first flight take?

(3)

- (c) What is the total time taken by Jill to get to Malta from New York airport?

(3)

**(Total: 7 marks)**

---

12 Use ruler and compasses only for your constructions in this question.

- (a) Mark point B on the line below so that AB is 7 cm long,  
On the base AB, construct a quadrilateral ABCD in which BC is 7 cm long whilst AD  
and DC are both 9 cm long. The size of  $\angle BAD$  is  $60^\circ$ .



- (b) What is the shape of quadrilateral ABCD?

(4)

trapezium

kite

parallelogram

rhombus

(1)

**(Total: 5 marks)**

---



- 13 The two ends of a running track are semicircles as shown in the figure below. The semicircles are joined by straight sides.

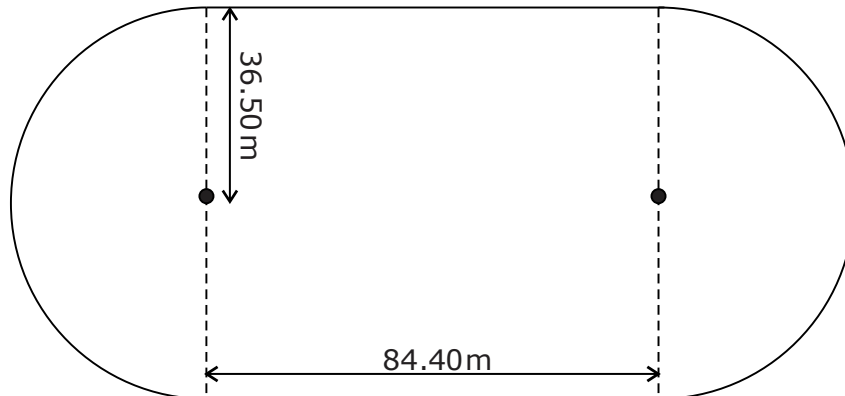

*Diagram not drawn to scale*

The radius of the semicircles is 36.50 m.

The length of each straight side is 84.40 m.

Work out the total length of the running track. Give your answer correct to the nearest cm.

**(Total: 4 marks)**

- 14 Frank paid a yearly season ticket of €200 to watch his football team play at his local stadium. Every time he went, he bought a meal for €8.

(a) Write down an expression for the total amount that Frank paid last year if he went  $x$  times to the stadium in that year.

(2)

(b) Last year Frank paid a total of €336 for his visits to the stadium. Find the number of times Frank went to the stadium last year.

(3)

**(Total: 5 marks)**

15 A line graph is plotted on the graph below.

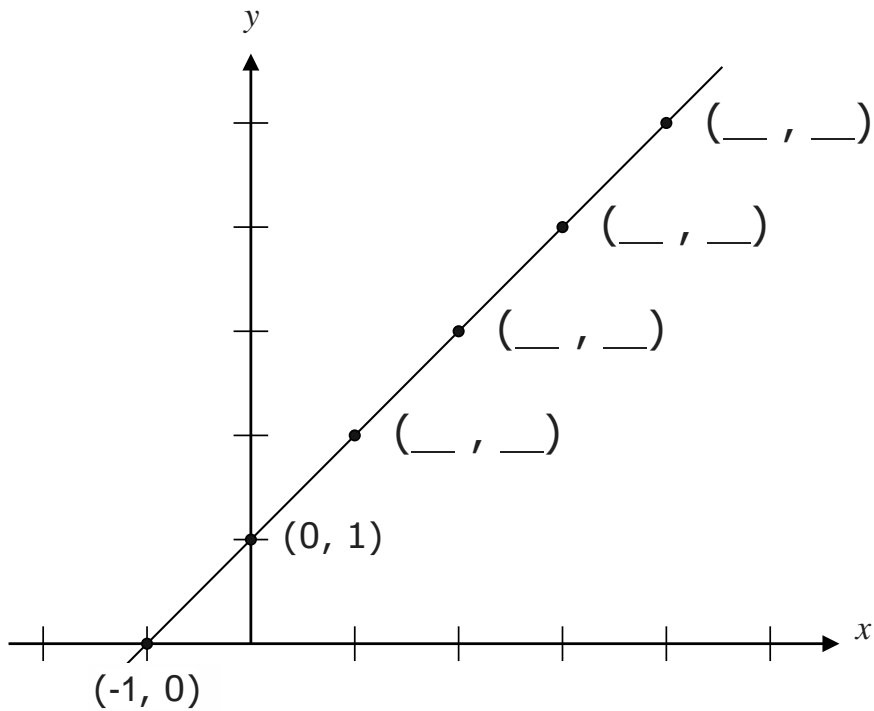

(a) Six points are marked on the line graph. In the space provided, write down the coordinates of each point. Two coordinates have already been marked. (2)

(b) Ana says that this line graph has equation  $y = x + 1$   
 Timmy says that this line graph has equation  $y - x = 1$

(i) Is Ana correct? Explain your reasoning.

(2)

(ii) Is Timmy correct? Explain your reasoning.

(2)

**(Total: 6 marks)**

- 16 Karl stands on horizontal ground 15 m away from the foot of building RST.  
Karl's eyes are 1.45 m above the ground.  
The angle of elevation of the top of the building, T, from Karl's eyes at K is  $30^\circ$ .

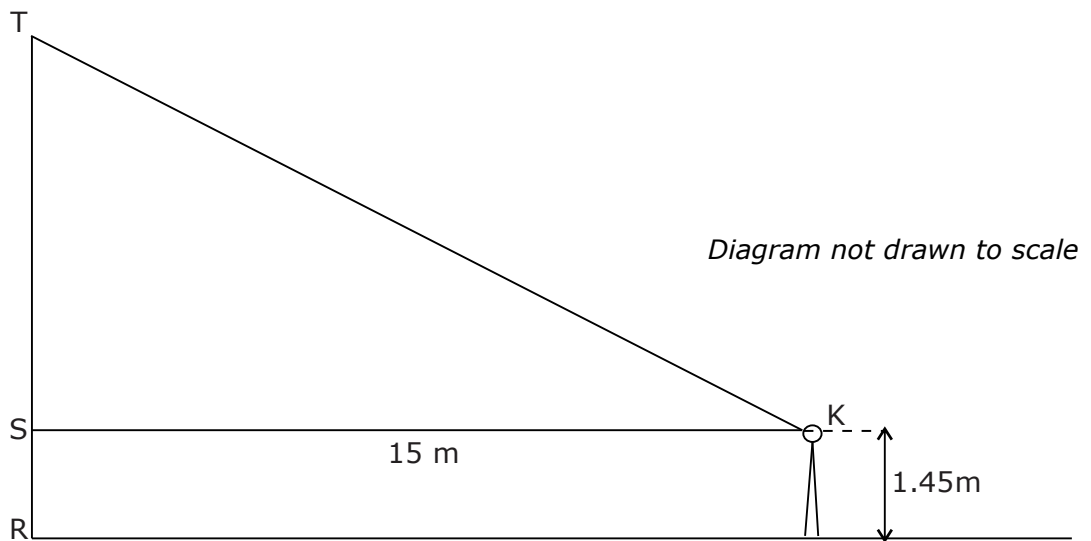

- (a) Mark on the diagram the angle of elevation of T from K. (1)  
(b) Work out the height of the building TR.

(4)

**(Total: 5 marks)**

- 17 Make  $s$  the subject of the formulae:

(a)  $p = q + rs$

(2)

(b)  $p = 3s^2 - 1$

(2)

**(Total: 4 marks)**

18

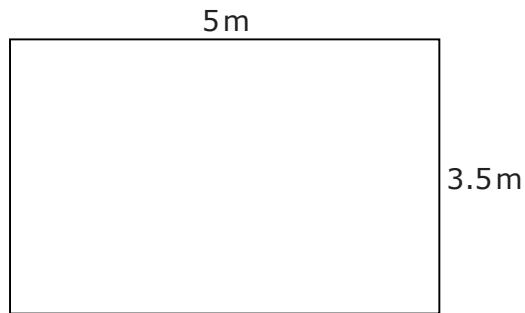

*Diagram not drawn to scale*

A room is 5 m long and 3.5 m wide.  
Sarah plans to tile this room.  
Each tile measures 50 cm by 50 cm.

(a) Work out the total number of tiles needed to tile the room.

(b) The tiles are only sold in packs of 4 tiles.  
Each tile pack costs €23.  
Work out the cost of buying enough tiles to tile the room.

(3)

(3)

**(Total: 6 marks)**

19 The shape below is made up of a large circular disc and two equal semi-circular holes.

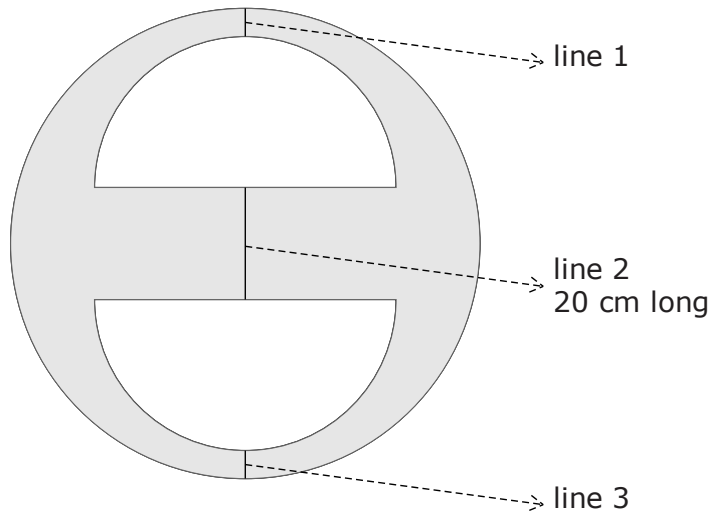

*Diagram not drawn to scale*

The larger circular disc has a diameter of 84 cm. The semicircles have a radius of 27 cm.

- (a) The shape has a horizontal and a vertical line of symmetry.  
 The three lines shown in the diagram lie along the vertical line of symmetry.  
 Line 2 is 20 cm long.  
 Work out the length of line 1.

(2)

- (b) Work out the shaded area.

(4)

**(Total: 6 marks)**

- 
- 20 A piece of metal 88 cm long is to be cut into 10 pieces.  
Seven of these pieces need to be equal in length.  
The other three pieces need to be equal to each other. These three pieces are each 2 cm longer than the seven shorter pieces.
- What is the length of the shorter pieces?

**(Total: 3 marks)**

- 
- 21 Francesca uses blue paint and white paint to make two mixtures of light blue paint.  
Mixture A contains blue paint to white paint in the ratio 3:5.  
Mixture B contains blue paint to white paint in the ratio 2:3.
- Which mixture has a higher proportion of blue paint? Explain your reasoning.

**(Total: 3 marks)**

**Blank Page**

**Blank Page**