

----- Do not write in the above space -----

1. Annalise boils water in a pot covered with a lid. After 10 minutes the water boils and steam comes out of the pot as she opens the lid.

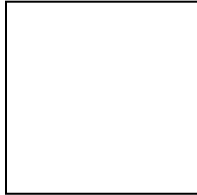

- a. In the boxes below draw a diagram showing how the particles of the pot, the water and the steam are spread out.



POT

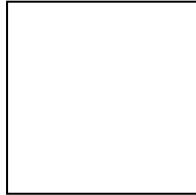

WATER

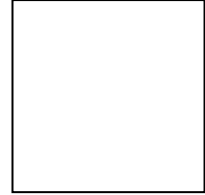

STEAM

[3 marks]

- b. Describe the motion of the particles in:

- i. the pot;

[1 mark]

- ii. water;

[1 mark]

- iii. steam:

[1 mark]

- c. As the water is getting hotter, explain what is happening to the temperature and to the energy of the molecules.

[2 marks]

- d. The water is then allowed to cool. State when the temperature of the water will stop decreasing. Explain.

[2 marks]

----- Do not write in the above space -----

2. The pottery water jar (*bomblu*) was a very useful vessel to carry water and to keep water cool for a long period of time. The stored water filters through the pores (very small holes) of the pottery and comes in contact with the outside dry environment where it then **evaporates**, producing cooling.



- a. i. In terms of water molecules, explain the term evaporation.

[2 marks]

- ii. Mention two factors which will increase evaporation.

[2 marks]

- iii. Explain how the process of evaporation keeps the water inside the clay water jar cool.

[2 marks]

- b. Calculate the change in temperature of 2000 g of stored water when one gram of water has evaporated, if 2219 J are lost per gram of evaporated water. (specific heat capacity of water = $4200 \text{ J/kg}^\circ\text{C}$,)

[4 marks]

----- Do not write in the above space -----

- 3.a. Define:
i. a vector quantity;

[1 mark]

- ii. a scalar quantity.

[1 mark]

- b. Classify the following quantities as vectors or scalars by listing them under the appropriate heading in the table below.

mass, distance, velocity, weight, displacement, acceleration, speed, pressure.

Scalar	Vector

[4 marks]

- c. A driver moves the car along a straight and level road as shown.

- i. Name the forces shown by arrows A and B.

A _____

B _____

(2 marks)

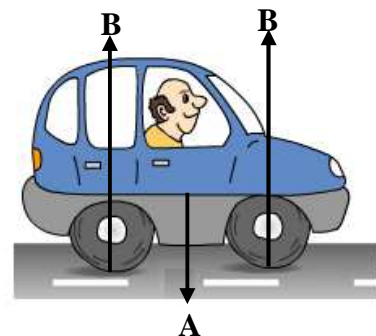

- ii. Two other forces acting on the car are the forward and the backward forces. At first, the forward force is larger than the backward force. What will happen to the speed of the car?

(1 mark)

- iii. After a time, the forward and backward forces are balanced. What will happen to the speed of the car?

----- Do not write in the above space -----

- 4.a. Carla connects three bulbs A, B and C and three switches S_1 , S_2 and S_3 in a circuit as shown in the diagram. (1 mark)

i. Which bulb/s, if any, will light when:

- S_1 and S_2 only are closed? _____
- S_1 and S_3 only are closed? _____
- S_1 only is closed? _____

[3 marks]

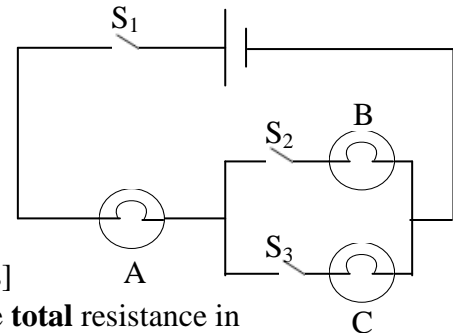

- ii. Each bulb has a resistance of $10\ \Omega$. Calculate the **total** resistance in the circuit, when all the switches in the circuit are closed.

[2 marks]

- b. Jacob plans a circuit to connect three sockets A, B and C to the mains supply as shown. He suspects that the circuit may **not** work correctly.

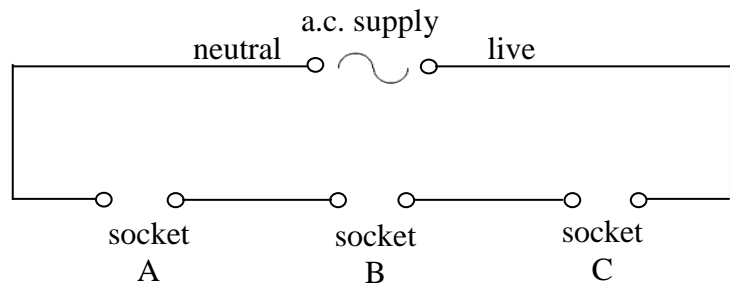

- i. If an electric heater is plugged in one of the sockets of the above circuit, no current flows in the circuit. Explain why.

- ii. When three electric heaters are plugged in sockets A, B and C respectively, current flows in the circuit but the heaters give out less heat than they were designed to do. Explain. [1 mark]

- iii. Draw a circuit diagram to show how the three sockets can be wired correctly to the mains supply so that the three heaters can operate normally. [2 marks]
- [1 mark]

- iv. Name the arrangement of sockets in the circuit drawn in question (iii) above.

[1 mark]

----- Do not write in the above space -----

5. Rachel investigates how the resistance of a thermistor varies with temperature. She sets up the apparatus shown below. She records the resistance of the thermistor at different temperatures.

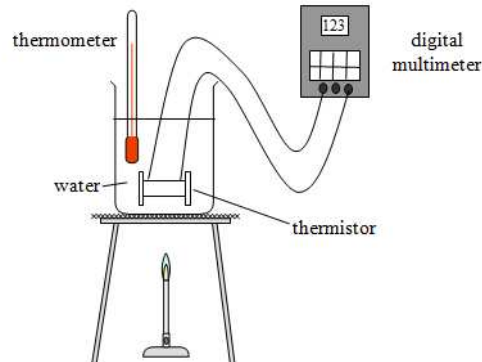

- a. Before Rachel takes each reading, she **removes the Bunsen burner** and **stirs the water**. Explain why she follows this procedure.

[2 marks]

The table below shows the readings she obtained.

Resistance / Ω	10400	6400	4200	2800	1800	1000
Temperature / $^{\circ}\text{C}$	10	20	30	40	50	60

- b. Plot a graph of Resistance / Ω on the y-axis against Temperature / $^{\circ}\text{C}$ on the x-axis. [5 marks]
- c. What can you conclude from the shape of the graph obtained?

[1 mark]

- d. Circle the correct graph below A, B or C which represents the V-I graph of a thermistor. [1 mark]

[1 mark]

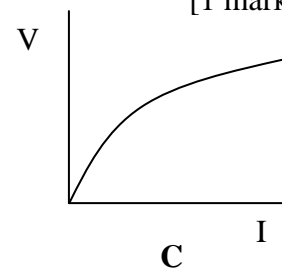
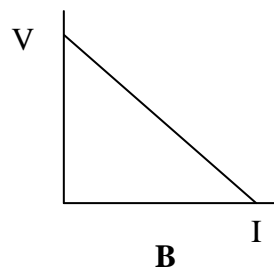
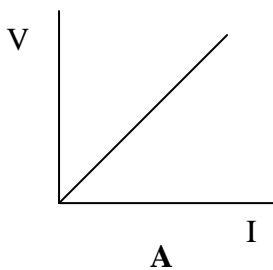

- e. Underline the correct term:

A thermistor is an **ohmic** / **non-ohmic** conductor.

[1 mark]

----- Do not write in the above space -----

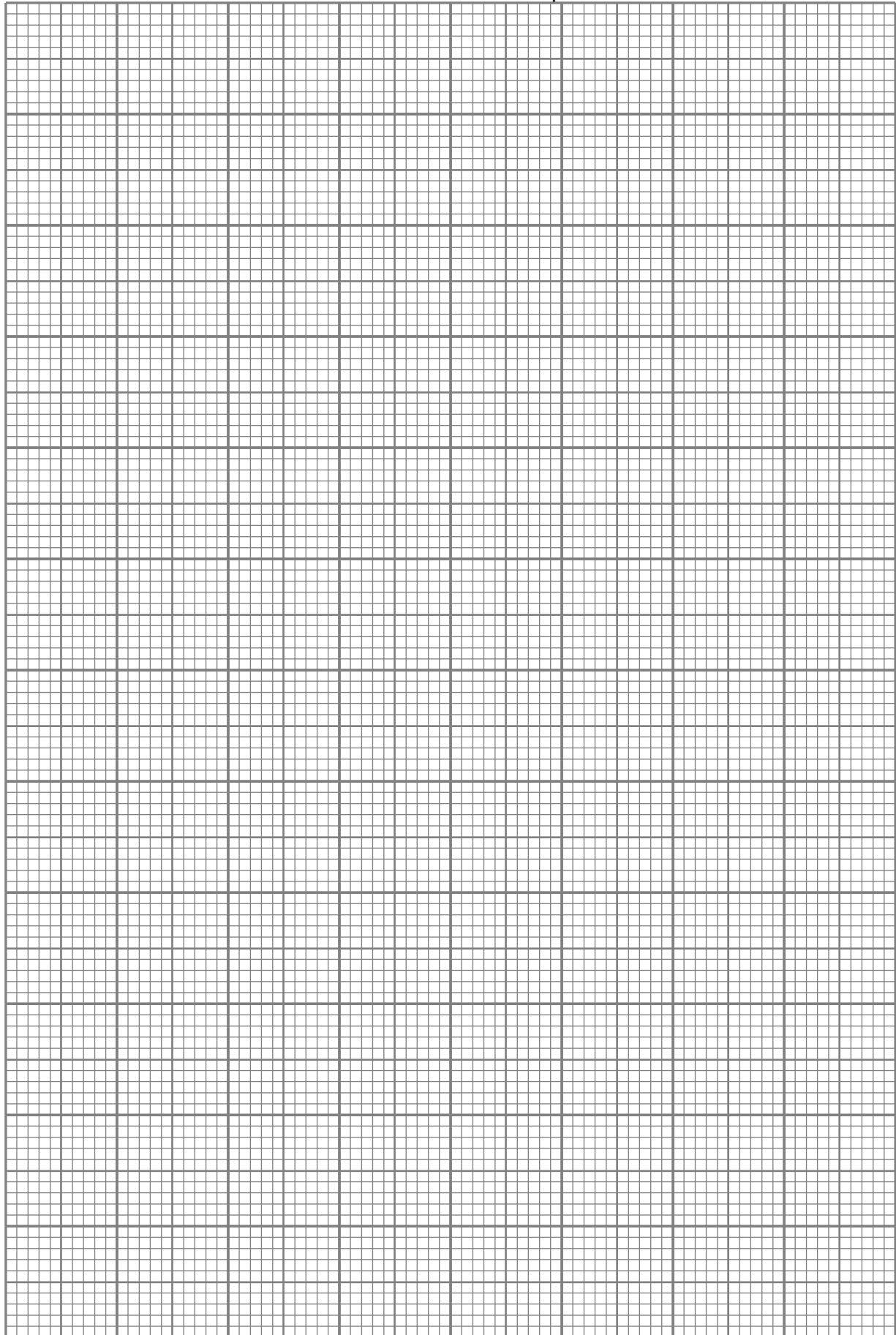

----- Do not write in the above space -----

6. a. Jonathan uses a whistle to emit a sound with a frequency of 255 Hz.
- i. The speed of sound in air is 330 m/s. Calculate the wavelength of the sound wave produced by the whistle.

[2 marks]

- ii. Both light and sound are types of waves. Give one example to show that light travels faster through air than sound.

[2 marks]

- b. A steel pipe 88.4 m long is struck at one end by a hammer. A sound sensor at the other end of the pipe, connected to a digital timer, records a delay of 0.24 s between the arrival of the sound transmitted by the pipe and that transmitted by the air.

hammer

sound sensor

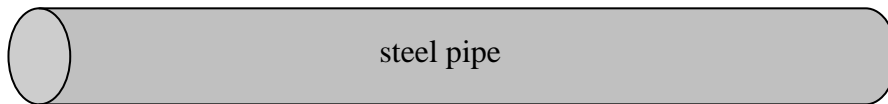

- i. Sound travels as **longitudinal** waves. Explain the term in bold.

[1 mark]

- ii. Explain why two separate sounds are recorded.

[1 mark]

- iii. The speed of sound in air is 330 m/s. Calculate the time taken for the first sound to be recorded.

[2 marks]

- iv. Calculate the speed of sound in the steel pipe.

[2 marks]

----- Do not write in the above space -----

7. Kurt releases a glass marble from the top of a high building.
a. The marble is said to accelerate downwards at 10 m/s^2 . What does this value equate to?

[2 marks]

- b. In the space provided sketch the velocity time graph for the falling ball. [ignore air resistance]

[2 marks]

- c. If the ball takes 2.1 s to fall to the ground, what is the final value of the velocity?

[2 marks]

- d. Calculate the height of the building.

[2 marks]

- e. If a bigger marble was dropped, what would be the effect on answer (c)? Explain.

[2 marks]

----- Do not write in the above space -----

8. Many countries have agreed to decrease the emission of carbon dioxide by making more efficient use of energy and by making more use of renewable sources of energy.

a. Explain **two** ways how the emissions of carbon dioxide may be decreased.

[2 marks]

b. Indicate **two** ways how you can contribute to this effort.

[2 marks]

c. The use of biomass as a source of energy is increasing. Give **one** advantage and **one** disadvantage of this source of energy.

[2 marks]

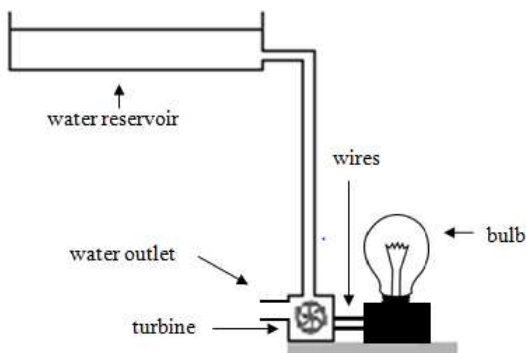

d. A student built the model shown in the diagram to demonstrate hydroelectric power.

i. State the input and output forms of energy in such a model.

[2 marks]

ii. The power output of the bulb is 3 W. Calculate the power input if the system 40% efficient.

[2 marks]

----- Do not write in the above space -----
9. Katrina found a box of iron nails and brass screws. She uses a bar magnet to separate them.

a. Why is it possible for her to separate them using a bar magnet?

[2 marks]

b. Explain how one can find the poles of bar magnet using a plotting compass.

[2 marks]

c. Draw a labelled diagram of a bar magnet and the field pattern around it.

d. State which are the strongest parts of the magnet. [3 marks]

[1 mark]

e. Indicate two ways how a bar magnet can lose its magnetism.

[2 marks]

----- Do not write in the above space -----

10. Parts of a metal bracelet of a watch were found to be radioactive. Further analysis revealed that the steel pins in the bracelet were contaminated with traces of cobalt-60, a radioactive form of the metal cobalt. The source of the contamination was traced to a small factory that had provided the steel for the bracelet pins. It is thought that a device used in hospitals and which contains a large dose of cobalt-60, had been accidentally melted down as scrap at this factory and used in production of steel for watches.

a. The radioactive isotope of cobalt is represented by the symbol ${}_{27}^{60}\text{Co}$. How many protons and neutrons are there in the nucleus of this isotope?

Protons _____ Neutrons _____ (2 marks)

b. This situation shows that uncontrolled disposal of this metal has been responsible for dangerous radioactive contamination. Describe how radioactive sources should be handled and stored.

 _____ (2 marks)

c. A radiographer uses a detector connected to a counter to investigate the activity of a radioactive source. She records an average of 25 counts per minute as background radiation. She then measures the activity of the source with different materials placed between the source and the detector. She records the following results.

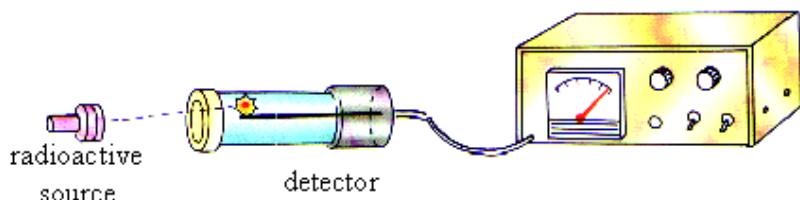

Material between source and detector	Average counts per minute
No material	1900
Card 1 mm thick	1210
Lead 1 mm thick	25

State whether or not each of the following radiations is given out by the source. Give one reason for each of your answers.

- i. Alpha _____
- ii. Beta _____
- iii. Gamma _____

(3 marks)

d. Name one source of background radiation. _____ (1 mark)

e. The half life of the cobalt-60 is 5 years. What percentage of the original source will still be present after 15 years? Show your working.

 _____ (2 marks)

----- Do not write in the above space -----

- c. Mr. Briffa filled two glasses with 150 cm^3 of water each. In one glass, he dissolved a lot of salt but the volume remained the same as the other one. He asked his daughter to find in which glass was the salt. Briefly explain how she could do this without tasting it.

[2 marks]

- d. At school the next morning the teacher asked Kimberly and her classmates to find the volume of a **very small** copper model of the Eiffel Tower.



- i. List three steps the students should follow to find the volume of the model.

[3 marks]

- ii. State two precautions the students should take to find the volume of the model.

[2 marks]

- iii. Given that the volume of the copper model is 50 cm^3 and its mass is 0.446 kg , calculate the density of copper.

[3 marks]

- iv. Would a smaller model made from the same material have a different density? Explain.

[2 marks]

----- Do not write in the above space -----

2. *This question is about heat transfer and specific heat capacity of copper.*

- a. The vacuum flask was invented by Scottish physicist Sir James Dewar in 1892. It consists of two flasks, placed one within the other and joined at the neck. The gap between the two flasks is a vacuum. The flask surfaces facing the gap, are silvered. Most heat transfer occurs through the flask's neck and opening, where there is no vacuum. Vacuum flasks are commonly made of metal, glass, foam, or plastic.



- i. Why is there a gap between the two flasks?

[1 mark]

- ii. Name two methods of heat transfer by which heat cannot pass through a vacuum.

[2 marks]

- iii. Another type of heat transfer will still occur through the vacuum. State this type of heat transfer.

[1 mark]

- iv. Explain how heat losses by this type of heat transfer are kept to a minimum.

[2 marks]

- v. Suggest a suitable material which can be used for the flask stopper. Give a reason for your choice.

[2 marks]

- vi. The vacuum flask is filled with a cold liquid on a hot summer day. After two hours the liquid was found to be at room temperature. Indicate with an arrow the direction of heat transfer.

[1 mark]

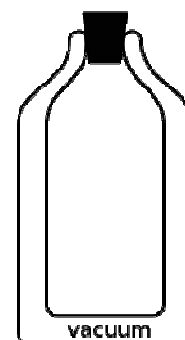

----- Do not write in the above space -----

- vii. Suggest one possible reason that might have made the water inside the flask get warmer.

[1 mark]

- b. Paul and Anton were asked by their teacher to determine the specific heat capacity of a block of copper. They were given the apparatus listed below.

copper block, lagging, electric immersion heater, thermometer, glycerine/oil, power supply, joulemeter .

[A joulemeter is an instrument that measures energy]

- i. In the space below, draw and label the diagram of the setup. [4 marks]

- ii. Why is glycerine/oil given to the students?

(2)

- iii. Why is lagging important?

(1)

- iv. If a joulemeter was not available, state which three quantities the students need to measure in order to find the energy supplied by the heater.

[3 marks]

----- Do not write in the above space -----

3. *This question is about the properties of light rays.*

- a. Jonathan and Rebecca investigate the refraction of light rays in the school laboratory. They use a rectangular glass block and any other suitable equipment to observe how light passes from one medium to another.

i. Draw a setup of the equipment required to investigate the refraction of light rays through a glass block.
[2 marks]

ii. Briefly explain how the angle of incidence and the angle of refraction are measured.

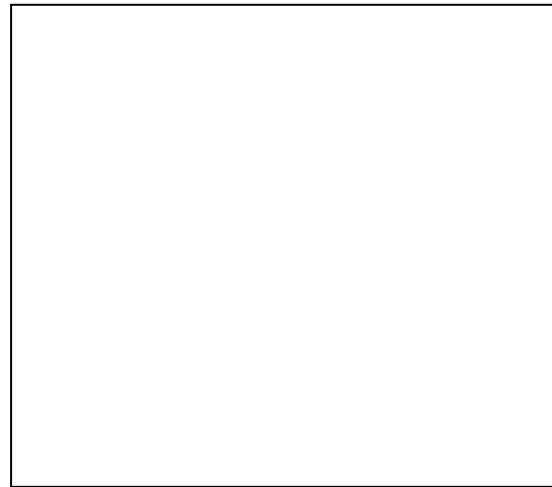

iii. Name **two** precautions they need to take during the investigation.

[2 marks]

iv. State what happens to the direction of the ray of light as:

- it passes from air to glass;

[2 marks]

- it passes from glass to air

[1 mark]

- b. A fibre optic is a flexible, transparent glass core surrounded by another transparent material of different refractive index (cladding). The fibre optic is as thick as a human hair. A ray of light enters the fibre optic at an angle of 40° to the normal as shown below.

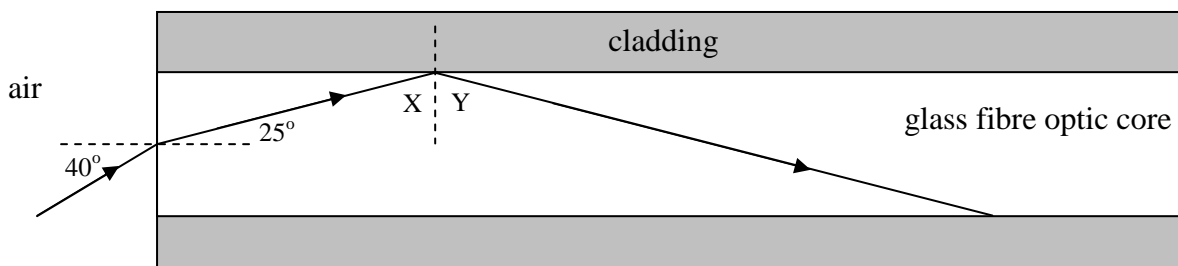

----- Do not write in the above space -----

- i. What happens to the speed of the incident ray as it enters from air to the fibre optic core? Give **one** reason for your answer.

[2 marks]

- ii. Use the values in the diagram to calculate the value of angle X.

[2 marks]

- iii. What is the value of angle Y? Give **one** reason for your answer.

[2 marks]

- iv. From the list below, underline **one** correct statement about light in the fibre optic core.

- Angle X is smaller than the critical angle
- Angle X is equal to the critical angle
- Angle X is larger than the critical angle

[1 mark]

- v. Complete the following:

The ray of light undergoes _____ at the boundary between the fibre optic core and the cladding.

[1 mark]

- c. Jonathan and Rebecca observe that an object at the bottom of a container full of water appears closer to them when viewed from vertically above.

- i. Explain why the object appears closer to Jonathan and Rebecca.

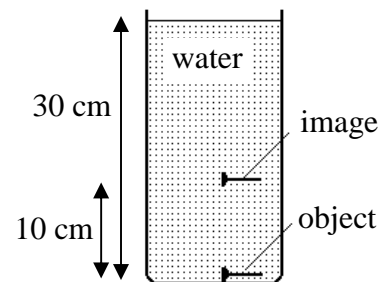

[1 mark]

- ii. Calculate the apparent depth of the object.

[1 mark]

- iii. Hence calculate the refractive index of water.

[2 marks]

----- Do not write in the above space -----

4. *This question is about the Earth and the universe.*

- a. The solar system contains planets, their satellites, asteroids and comets. The planets orbit the Sun and take different amounts of time to do this.
- i. What does the term *orbit* mean?

[2 marks]

- b. The table above shows details of some planets in our Solar System.

PLANET	DISTANCE FROM THE SUN/ 10^6 km	TIME FOR ONE ORBIT/days
Mercury	58	88
Neptune	4497	60200
Earth	150	365
Mars	228	687

- i. Which of the listed planets has the shortest orbit around the sun?

[1 mark]

- ii. State how long is a year on Mars.

[1 mark]

- iii. Briefly describe how part of the Earth is in day time whilst the other part is in night time.

[2 marks]

- iv. State the two factors that cause the seasons on the Earth.

[2 marks]

- c. The distances in space are quite vast. In fact distances are measured in light years.

- i. Define a light year.

[2 marks]

----- Do not write in the above space -----

- ii. Proxima Centauri is the nearest star to our sun. We can only see this star as it was four years ago. Explain.

[2 marks]

- iii. Name the instrument used to observe distant stars.

[1 mark]

- iv. Pluto used to be considered the ninth planet in our solar system. But in 2006 scientists renamed it as a dwarf planet. State the difference between a planet and a dwarf planet.

[1 mark]

- v. Earth is a small fraction of the Solar System. This Solar System is within the Milky Way galaxy. What is a galaxy?

[1 mark]

- d. Astronauts in orbit around the earth have to avoid space debris as this might collide with the spacecraft. The principal source of debris is from satellite waste and collision fragments. The debris travel at very high speeds, around 10000 m/s.

- i. Although the debris can be very small, it poses a very serious risk to the spacecraft and the astronauts. Explain why.

[2 marks]

- ii. Calculate the kinetic energy of a debris particle of mass 7 g, travelling at 10000 m/s.

[2 marks]

- iii. In a collision most of the kinetic energy of the debris is transferred to another type of energy. Name this energy.

[1 mark]

----- Do not write in the above space -----

5. *This question is about work.*

During a physics lesson, the teacher requested a group of students to investigate the factors which determine the amount of work done when going up a flight of stairs.

a. Define *work*.

[2 marks]

b. Three possible factors which the students indicated were time, vertical height and the weight of person. Which of these factors determine the amount of work done?

[2 marks]

c. List **five** steps required to investigate whether the weight of the person affects the amount of work done.

[5 marks]

d. A student of mass 45 kg takes 30s to go up a flight of 20 steps.

i. If each step is 10cm high what is the total vertical height?

[1 mark]

ii. Calculate the work done to go up the flight of stairs.

[2 marks]

----- Do not write in the above space -----

- iii. Calculate the power used by the student to go up.

[2 marks]

- iv. How does the work done change if the student goes up the same flight of stairs in 15 s?

[2 marks]

- e. A 200g trolley is placed on a horizontal surface. One end of a string is attached to it, while the other end passes over a pulley and is attached to four, 100 g masses hanging vertically down.

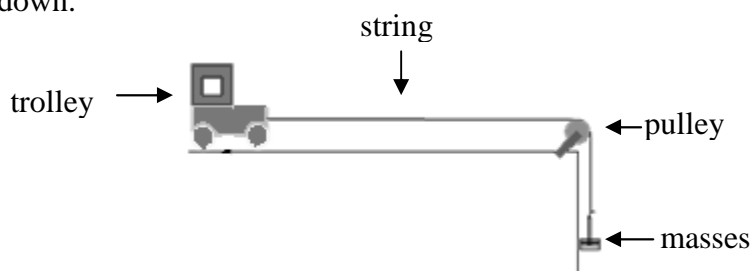

- i. What is the value of tension in the string?

[1 mark]

- ii. Calculate the acceleration of the trolley.

[2 marks]

- iii. What happens to the acceleration if a 1 kg mass is placed on the trolley?

[1 mark]