

MATRICULATION AND SECONDARY EDUCATION CERTIFICATE EXAMINATIONS BOARD  
UNIVERSITY OF MALTA, MSIDA

**SECONDARY EDUCATION CERTIFICATE LEVEL**  
**SEPTEMBER 2015 SESSION**

SUBJECT: **Physics**  
PAPER NUMBER: **I**  
DATE: **31<sup>st</sup> August 2015**  
TIME: **9:00 a.m. to 11:00 a.m.**

**Answer all Questions.**

**You are requested to show your working and to write the units where necessary.**

**When necessary, take g, acceleration due to gravity, as 10m/s<sup>2</sup>.**

<b>Density</b>	$m = \rho V$
<b>Pressure</b>	$F = p A$ $p = \rho g h$
<b>Moments</b>	Moment = $F \times$ perpendicular distance
<b>Energy and Work</b>	$PE = m g h$ $KE = \frac{1}{2} m v^2$ $W = F s$
	Work Done = energy converted $E = P t$
<b>Force and Motion</b>	$m a =$ unbalanced force $W = m g$ $v = u + a t$
	average speed = $\frac{\text{total distance}}{\text{total time}}$ $s = (u + v) \frac{t}{2}$
	$v^2 = u^2 + 2 a s$ $s = u t + \frac{1}{2} a t^2$ momentum = $m v$
<b>Waves</b>	$\eta = \frac{\text{speed of light in air}}{\text{speed of light in medium}}$ $v = f \lambda$
	$\eta = \frac{\text{real depth}}{\text{apparent depth}}$ Magnification = $\frac{\text{image distance}}{\text{object distance}}$
	Magnification = $\frac{\text{image height}}{\text{object height}}$ $T = \frac{1}{f}$
<b>Electricity</b>	$Q = I t$ $V = I R$ $E = Q V$
	$P = I V$ $R \propto \frac{1}{A}$ $E = I V t$
	$R_{\text{total}} = R_1 + R_2 + R_3$ $\frac{1}{R_{\text{total}}} = \frac{1}{R_1} + \frac{1}{R_2}$
<b>Electromagnetism</b>	$\frac{N_p}{N_s} = \frac{V_p}{V_s}$ $V_p I_p = V_s I_s$
<b>Heat</b>	$Q = m c \Delta \theta$
<b>Radioactivity</b>	$A = Z + N$
<b>Other equations</b>	Area of a triangle = $\frac{1}{2} b h$ Area of a trapezium = $\frac{1}{2} (a + b) h$
	Area of a circle = $\pi r^2$

1. Quantities in science are classified as scalar or vector.  
 a. State the difference between a vector and a scalar quantity.

[2 marks]

- b. Which of the following quantities are vectors or scalars? (The first one has been done for you.)

Quantity	Vector	Scalar
Distance		✓
Velocity		
Kinetic Energy		
Weight		
Displacement		
Speed		
Momentum		

[3 marks]

- c. Engineers were planning to install decorative columns made of marble, of density  $2560 \text{ kg/m}^3$ , in front of a building. The columns were 2.72 m tall and of radius 45 cm.

- i. Calculate the mass of one column.

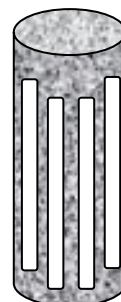

[2 marks]

- ii. Calculate the pressure exerted by each column on the ground.

[2 marks]

- iii. Engineers found out that the ground beneath the columns would not withstand the pressure calculated in part c(ii). Suggest one possible change to each column, the engineers can do, to solve this problem.

[1 mark]

2. The diagram shows the solar system. Pluto orbits beyond Neptune around the sun.

- a. The orbit of Pluto is at an approximate distance of  $6.0 \times 10^{12}$  m from the Sun. Pluto is also very small, roughly 60 times smaller than the Earth.
- i. Explain the meaning of the term 'orbit'.

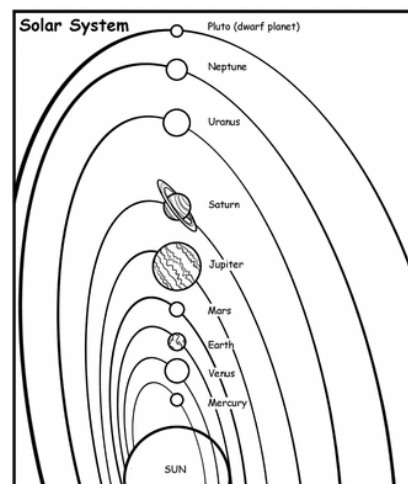

---



---

[1 mark]

- ii. Predict whether the gravitational force between Pluto and the Sun is greater, the same or smaller than the force between the Earth and the Sun. Give two reasons for your answer.

---



---

[3 marks]

b. Complete the sentence below.

Pluto is known as a \_\_\_\_\_ planet because \_\_\_\_\_

---

[2 marks]

c. When looking through a small telescope, Pluto appears like a faraway star. Explain the difference between the light coming from Pluto and that coming from a star.

---



---

[2 marks]

d. The table shows some data about the planets moving around the Sun.

Planet	Average Density /	Gravity at surface	Time of Orbit around the Sun
Venus	5.2	9	0.6
Earth	5.5	10	1.0
Mars	3.9	4	1.9
Jupiter	1.3	26	12

On which planet would a mass of 3 kg have the least weight? Give one reason for your answer.

---



---

[2 marks]

3. A metal spherical air-filled container is to be heated using solar energy.

a. By what process is energy transferred from the sun to earth?



[1 mark]

b. What colour would you recommend to paint the sphere so that it heats up quickly? Explain your choice of colour.

[2 marks]

c. What happens to the air inside the sphere and to its pressure when it receives energy from the sun?

[3 marks]

d. Describe in terms of molecules the structure of a solid and that of a gas.

Solid:

Gas:

[4 marks]

4. The graph below shows the journey of a car.

- a. State in which parts of the graph is the car moving at:
- i. constant velocity:

---



---

- ii. at rest:

---



---

[2 marks]

- b. Calculate the average speed of the car for the whole journey.

---



---

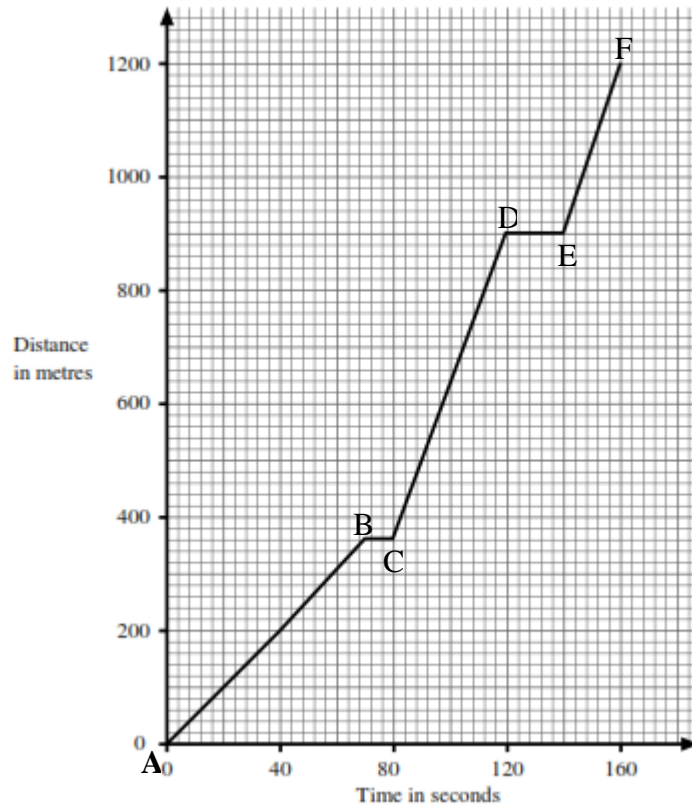

[2 marks]

- c. Calculate the time for the whole journey if the car was driven at a constant velocity of 15 m/s.

---



---

[2 marks]

- d. Draw on the grid above what the distance-time graph would look like if the car was driven at a constant velocity of 15 m/s for the whole journey. [2 marks]

- e. On arriving close to destination the car was decelerated from 15 m/s to rest in 37.5s. Calculate the deceleration of the car.

---



---

[2 marks]

5. A headlamp bulb has a filament made of tungsten metal. This is how the current through the bulb rises when the voltage across it is increased:

Voltage in V	0	2	4	6	8	10	12
Current in A	0	3.6	5.6	7.0	8.2	9.2	10.0

- a. Plot a graph of Current (y-axis) against Voltage (x-axis). [4 marks]

Use your graph to find:-

- i. the current flowing when the voltage is 9V;

[1 mark]

- ii. the resistance of the bulb when the current is 4A.

[2 marks]

- b. Why is the graph not a straight line?

[2 marks]

- c. Mark your graph with an (x) at the point where the temperature is highest.

[1 mark]

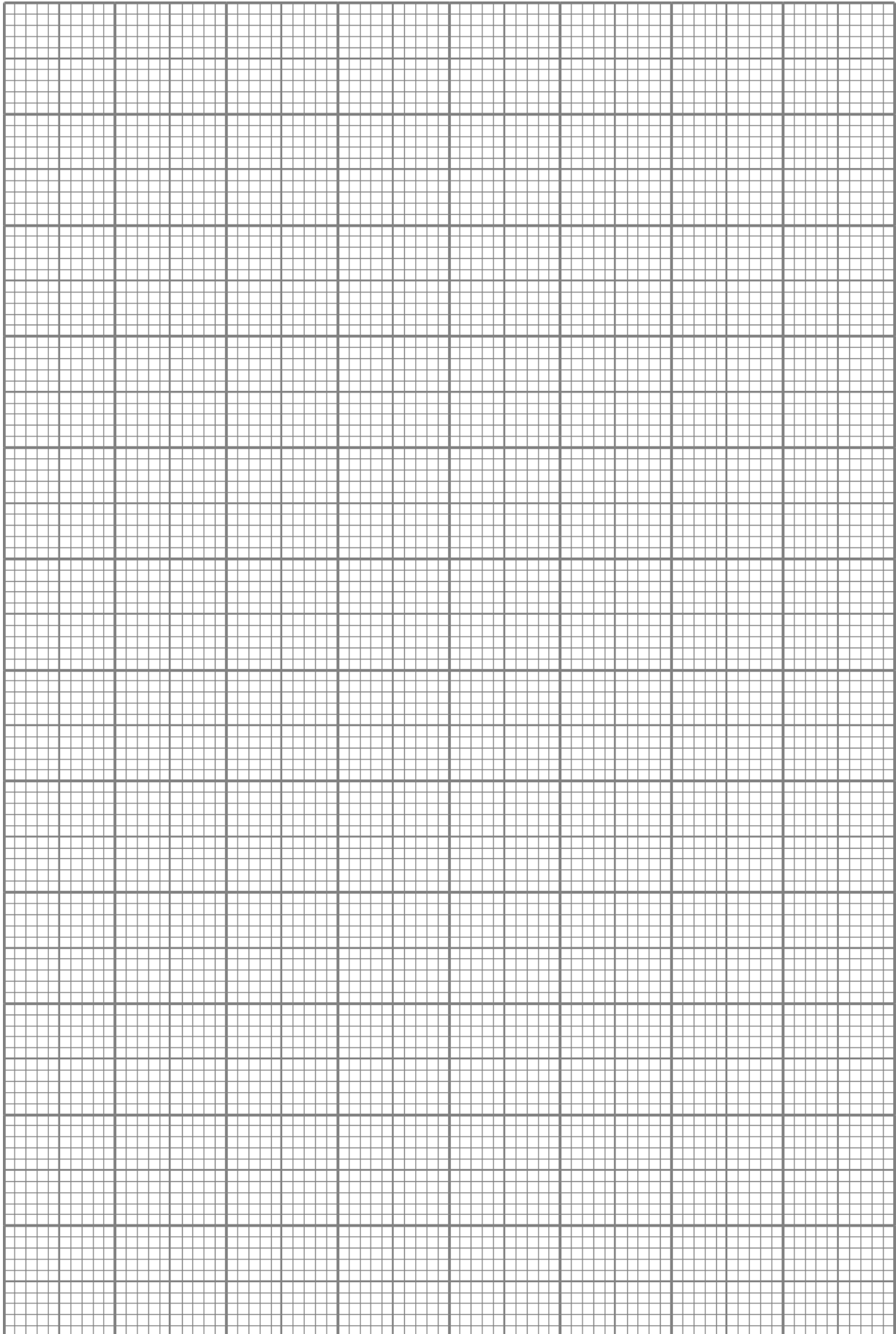

6. A CRO (Cathode Ray Oscilloscope) can be used to show how the voltage changes in a circuit. When a circuit is connected to a CRO, the following image was obtained.

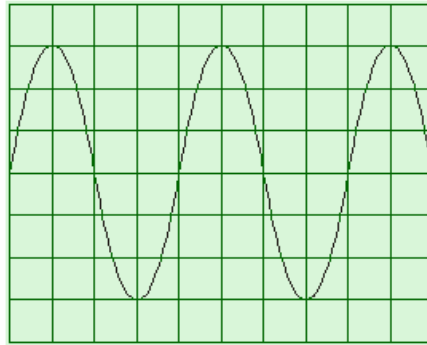

a. What type of current is flowing in the circuit? Explain.

\_\_\_\_\_

\_\_\_\_\_

[2 marks]

b. If the above trace was observed in 0.05 s. Find the frequency.

\_\_\_\_\_

\_\_\_\_\_

[2 marks]

c. A diode is connected to a circuit in series to the power supply. On the same axis, draw the new image that would be seen on the CRO now. [2 marks]

d. What do we call this process?

\_\_\_\_\_

[1 mark]

e. Draw in the space provided, the diagram that would be seen on the CRO if the source of the voltage is replaced with a battery. Explain your reasoning.

\_\_\_\_\_

\_\_\_\_\_

[2 marks]

f. Name a possible **source** of voltage in part (a).

\_\_\_\_\_

[1 mark]



7. A see-saw is 3m long from end to end.

a. State the principle of moments.

---



---

[2 marks]

b. If Andrew of mass 35 kg is sitting on one end, how far away from the centre of the see-saw should Daniela, of mass 42 kg, sit to balance the see-saw? (Your answer should include a diagram showing the forces acting on the see-saw.)

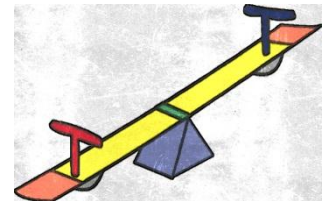

---



---



---

[3 marks]

c. As Andrew is sitting on the balanced see-saw, his cat jumps on him and the see-saw becomes unbalanced. What must Daniela do for the see-saw to balance again?

---



---

[1 mark]

d. Andrew and Daniela go on a see-saw pivoted on a helical spring. When they both sit on opposite sides and the see-saw is balanced, the see-saw is 40 cm above the ground.

i. What happens to the see-saw when both children come off?



---



---

[2 marks]

ii. John and Lisa, each of mass 28 kg sit on the see-saw. Will the see-saw balance again at 40 cm above the ground? Explain.

---



---

[2 marks]

8. Willebrord Snellius was a Dutch astronomer who studied refraction of light waves in the 17<sup>th</sup> Century.

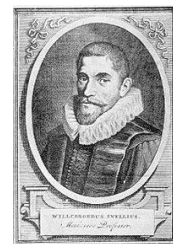

a. Complete the following diagrams.

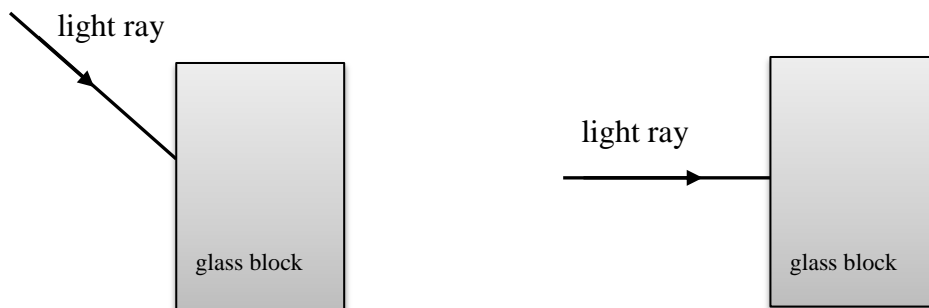

(3 marks)

b. Name two changes that occur when light is refracted.

---



---

[2 marks]

c. A fisherman sees a fish at an apparent depth below the surface of the water of 175 cm. Given that the refractive index of water is 1.33, what is the true depth, in metres, of the fish below the water's surface?

---



---

[2 marks]

d. Swimming pool owners fix depth markers to indicate the depth of the pool. With the aid of a ray diagram, explain why a pool filled with water looks shallower.



air \_\_\_\_\_  
 water \_\_\_\_\_

---



---



---



---

[3 marks]

floor of pool

9. Microwaves are classified as electromagnetic radiation. They are reflected from metals but can pass through glass and some plastics.



a. How does food heat up in a microwave?

[2 marks]

b. Name a type of electromagnetic wave which has a longer wavelength and another which has a shorter wavelength than microwaves.

[2 marks]

c. A microwave oven releases microwaves of frequency 4000 MHz. If the speed of light is  $3 \times 10^8$  m/s, calculate the wavelength of the microwaves.

[2 marks]

d. X-rays and gamma rays are also electromagnetic waves. State one way in which they differ from microwave radiation and one way in which they are similar.

[2 marks]

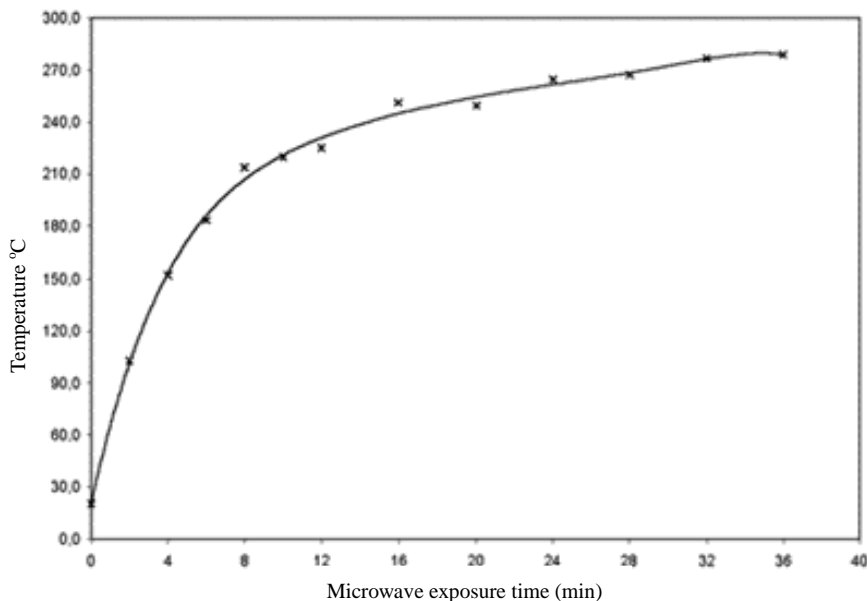

e. The following is a graph showing the change in temperature with time when heating oil samples in a microwave oven. What is the average change in temperature per second during the first 6 minutes?

\_\_\_\_\_

\_\_\_\_\_

\_\_\_\_\_

[2 marks]

10. When installing glass panes, glass fitters use rubber suction cups (suckers).  
a. Define atmospheric pressure.



---

---

[2 marks]

- b. Explain how atmospheric pressure acts when glass fitters are using the rubber suction cups.

---

---

[2 marks]

- c. With the aid of a diagram and with reference to atmospheric pressure, describe how a person can suck a liquid from a container using a straw.

---

---

---

---

[3 marks]

- d. Another instrument used to measure atmospheric pressure is the mercury barometer. What happens to **h** when the atmospheric pressure increases?

---

[1 mark]

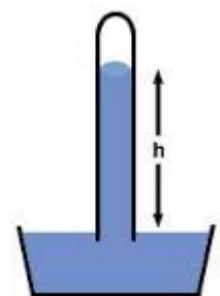

- e. What would happen to the mercury level if the barometer was gradually moved to outer space? Why?

---

---

[2 marks]

MATRICULATION AND SECONDARY EDUCATION CERTIFICATE EXAMINATIONS BOARD  
UNIVERSITY OF MALTA, MSIDA

**SECONDARY EDUCATION CERTIFICATE LEVEL**

**SEPTEMBER 2015 SESSION**

SUBJECT:	<b>Physics</b>
PAPER NUMBER:	<b>IIB</b>
DATE:	<b>31<sup>st</sup> August 2015</b>
TIME:	<b>4:00 p.m. to 6:00 p.m.</b>

**Answer all Questions.**

**You are requested to show your working and to write the units where necessary.**

**When necessary, take g, acceleration due to gravity, as 10m/s<sup>2</sup>.**

<b>Density</b>	$m = \rho V$	
<b>Pressure</b>	$F = p A$	$p = \rho g h$
<b>Moments</b>	Moment = $F \times$ perpendicular distance	
<b>Energy and Work</b>	$PE = m g h$	$KE = \frac{1}{2} m v^2$
	$W = F s$	
<b>Force and Motion</b>	Work Done = energy converted	
	$E = P t$	
	$m a =$ unbalanced force	$W = m g$
<b>Waves</b>	$v = u + a t$	$v = f \lambda$
	average speed = $\frac{\text{total distance}}{\text{total time}}$	$s = (u + v) \frac{t}{2}$
	$v^2 = u^2 + 2 a s$	$s = u t + \frac{1}{2} a t^2$
<b>Electricity</b>	momentum = $m v$	
	$\eta = \frac{\text{speed of light in air}}{\text{speed of light in medium}}$	
	$\eta = \frac{\text{real depth}}{\text{apparent depth}}$	Magnification = $\frac{\text{image distance}}{\text{object distance}}$
<b>Electromagnetism</b>	Magnification = $\frac{\text{image height}}{\text{object height}}$	$T = \frac{1}{f}$
	$Q = I t$	$V = I R$
	$P = I V$	$E = Q V$
<b>Heat</b>	$R \propto \frac{1}{A}$	$E = I V t$
	$R_{\text{total}} = R_1 + R_2 + R_3$	$\frac{1}{R_{\text{total}}} = \frac{1}{R_1} + \frac{1}{R_2}$
<b>Radioactivity</b>	$\frac{N_p}{N_s} = \frac{V_p}{V_s}$	$V_p I_p = V_s I_s$
<b>Other equations</b>	$Q = m c \Delta\theta$	
	$A = Z + N$	
<b>Other equations</b>	Area of a triangle = $\frac{1}{2} b h$	Area of a trapezium = $\frac{1}{2} (a + b) h$
	Area of a circle = $\pi r^2$	

1. *This question is about Electromagnetism.*

A student sets up a circuit consisting of a vertical copper wire connected to a power supply. The wire passes through a horizontal stiff board as shown.

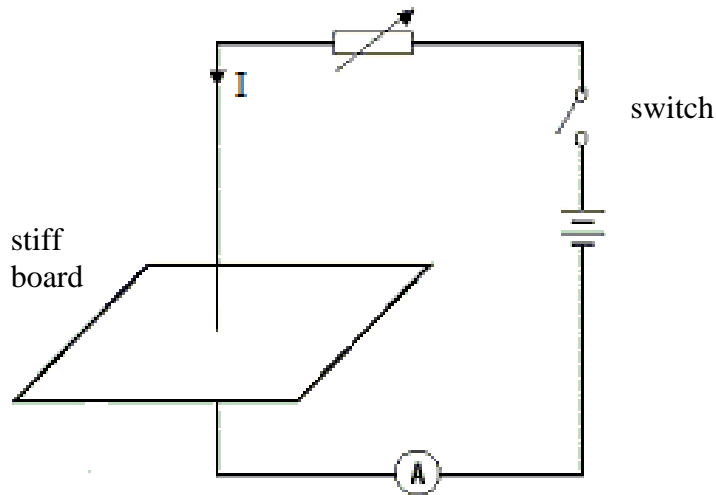

- a. For each of the following statements, state what is observed:
- i. With the switch open, the student brings a plotting compass close to the wire.

[2 marks]

- ii. With the switch closed, the student brings a plotting compass close to the wire.

[2 marks]

- b. What can be concluded from this?

[2 marks]

- c. On the stiff board, draw the magnetic field pattern you would expect.

[2 marks]

- d. If the current in the circuit is increased, what change would you expect to the magnetic field pattern?

[2 marks]

e. The following is a diagram of a simple electric motor which the student set up at home.

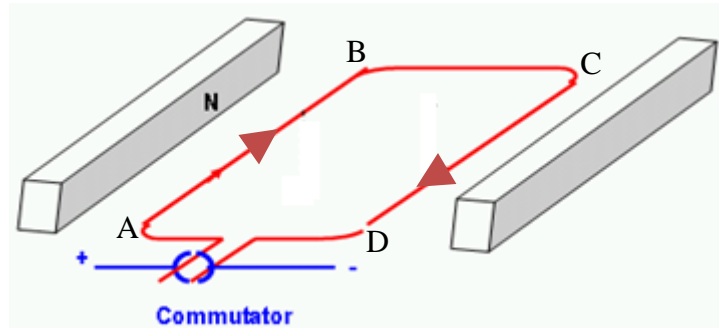

i. On the diagram draw the magnetic field pattern around AB and CD. [2 marks]

ii. Which sides of the coil experience a force when current flows in the coil?

\_\_\_\_\_

\_\_\_\_\_

[2 marks]

iii. For the given direction of the current, indicate on the diagram the direction the coil would rotate. [2 marks]

iv. State the rule have you applied to arrive to your answer in part e(iii).

\_\_\_\_\_

\_\_\_\_\_

[1 mark]

v. Without changing the coil, name two possible ways how the coil can be made to rotate faster.

\_\_\_\_\_

\_\_\_\_\_

[2 marks]

vi. What would happen to the wire as soon as the current is switched off?

\_\_\_\_\_

[1 mark]

2. *This question is about Lenses.*

Joseph and Victoria were on their way home after watching a film at the cinema. They were wondering how a very small projector can produce and project such a very large image onto the cinema screen.



a. What do we call this phenomenon? \_\_\_\_\_ [1 mark]

b. What type of lens is needed to produce such an image? \_\_\_\_\_ [1 mark]

c. During their Physics lesson, Joseph and Victoria were supplied with the apparatus shown in the following diagram.

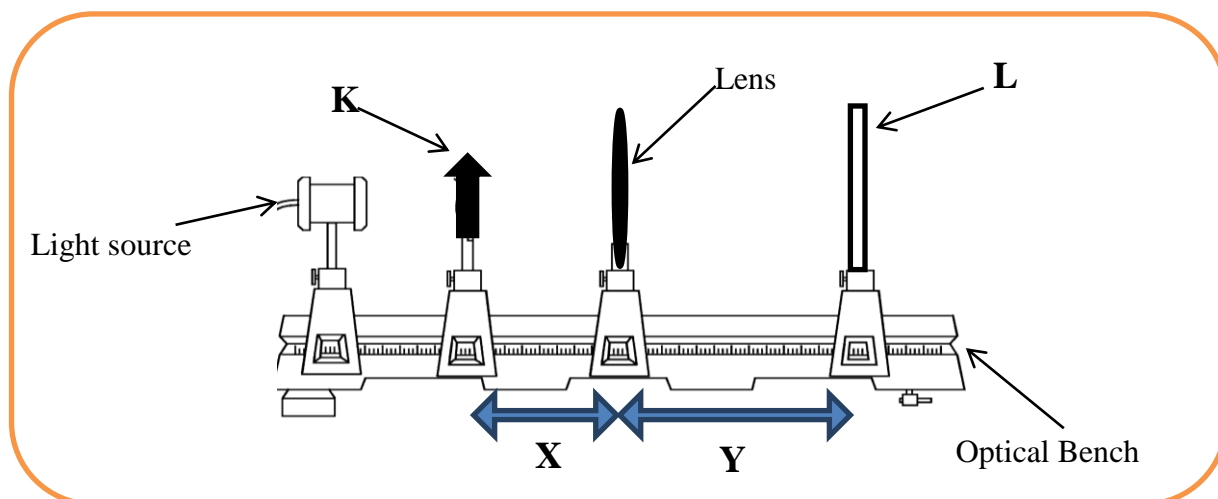

i. Which of items K and L are:  
 a screen \_\_\_\_\_ an object \_\_\_\_\_ [1 mark]

ii. What are the distances X and Y called?  
 X: \_\_\_\_\_ Y: \_\_\_\_\_ [2 marks]

d. Describe what happens, in terms of light rays, when the light source is switched on.  
 \_\_\_\_\_  
 \_\_\_\_\_ [2 marks]



e. What can Joseph and Victoria do to obtain different values of X and Y while keeping the lens in a fixed place?

[3 marks]

f. Give one precaution they had to take.

[1 mark]

g. The figure on the right shows scale drawings of a window frame and the image of the frame produced on a screen by a converging lens.

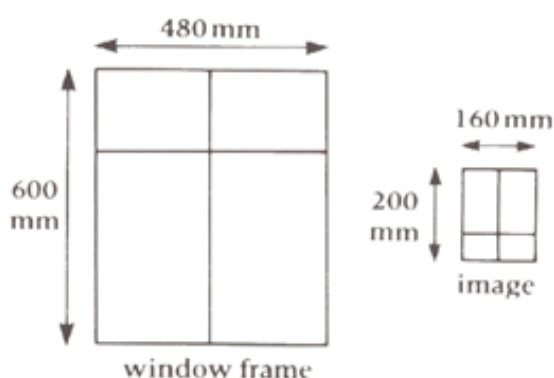

i. Calculate the magnification of the image.

[2 marks]

ii. The image of the frame was produced 45 mm from the lens. Determine the distance of the actual frame from the lens.

[2 marks]

h. Victoria told Joseph that they need to make one change in the window frame setup to be similar to that used in the cinema projector.

i. Explain what needs to be changed.

[2 marks]

ii. Describe how, using the same apparatus, Joseph and Victoria can find the focal length of the lens.

[3 marks]

3. *This question is about specific heat capacity*

- a. Trudy wanted to determine the specific heat capacity of an aluminium block. She set up the apparatus shown.

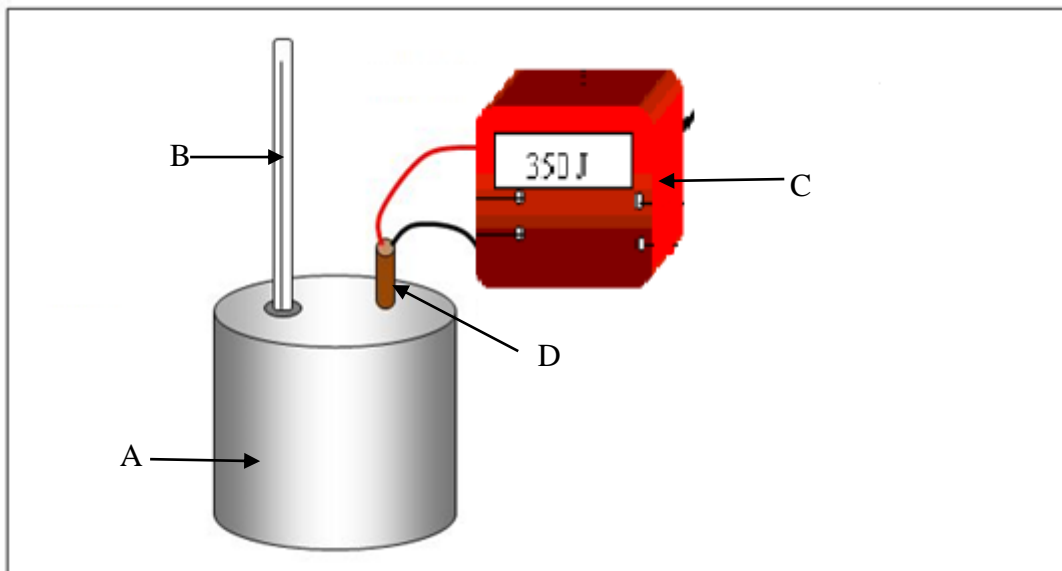

- i. Label the parts:

A \_\_\_\_\_

B \_\_\_\_\_

C \_\_\_\_\_

D \_\_\_\_\_

[4 marks]

- ii. The equation which needs to be used is  $Q = m c \Delta\theta$ . State what each symbol represents.

Q \_\_\_\_\_

m \_\_\_\_\_

c \_\_\_\_\_

$\Delta\theta$  \_\_\_\_\_

[4 marks]

- iii. Put the following sentences in the correct order to describe how the experiment is to be carried out.

Record the initial temperature of the metal block.	
Switch off the power supply after a time interval $t$ minutes.	
Plug in the joulemeter and switch it on.	
Calculate the rise in temperature.	
Allow time for the heat energy to spread throughout the metal block.	
Set up the apparatus as shown in the diagram.	
Record the highest temperature of the metal block.	
Record the final joulemeter reading.	
Find the mass of the metal block.	

[4 marks]

- iv. Mention **two** precautions that need to be taken during the experiment.

[2 marks]

- b. The specific heat capacity of water is  $4200 \text{ J/kg}^\circ\text{C}$ .

- i. How much energy needs to be given to 500 g of water so that its temperature rises by  $10^\circ\text{C}$ ?

[2 marks]

- ii. If 1 kg of water is used instead, how much energy is required?

[2 marks]

- iii. A teaspoon is placed in the water. After some time, the end of the teaspoon feels warm when touched. Explain.

[2 marks]

**4. This question is about radioactivity**

Chernobyl was a catastrophic nuclear accident that occurred on 26 April 1986 at the Chernobyl Nuclear Power Plant in Ukraine. The radioactive isotopes in the Chernobyl fallout which caused most concern were iodine 131 and caesium 137. Both are beta and gamma emitters.

a. What is the third type of radiation beside the two mentioned above?

---

[1 mark]

b. Name which of the three types of radiation:

i. is a form of electromagnetic radiation

---

ii. carries a positive charge

---

iii. is an electron

---

iv. travels at the speed of light

---

v. is stopped by skin or thick paper

---

vi. is the most massive

---

vii. is the most ionizing

---

[7 marks]

c. From which part of the atom do the beta and gamma rays come?

---

[1 mark]

d. After this nuclear accident, iodine 131 absorbed in rainfall, found its way into milk. The symbol for iodine is  $^{131}_{53}\text{I}$

i. Explain what the number 131 tells you about the iodine atom.

---

[1 mark]

ii. What do we call the number 131?

---

[1 mark]

iii. What does the number 53 represent?

---

[1 mark]

iv. After the accident, a milk sample containing iodine 131, was measured for a number of days. The graph shows the activity against time. Estimate the half-life of iodine 131 and show on the graph how you arrived at your answer.

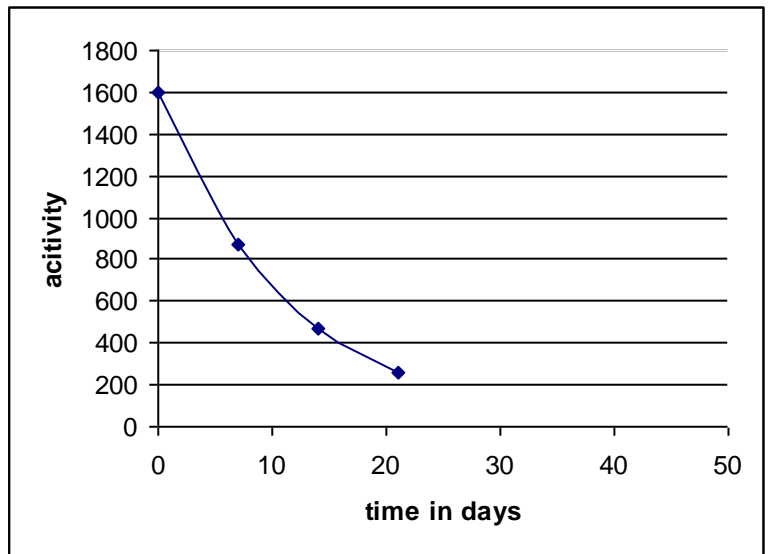

\_\_\_\_\_

\_\_\_\_\_

[2 marks]

e. Caesium 137 has a half life of 30 years.

i. If its activity initially was 1000 counts, how much will the activity be in 2046 after 60 years? Explain your working.

\_\_\_\_\_

\_\_\_\_\_

[2 marks]

ii. Give a reason why caesium 137 could cause more long term problems than iodine 131.

\_\_\_\_\_

[1 mark]

iii. Caesium has 40 known isotopes. The atomic masses of these isotopes range from 112 to 151. What is the difference between caesium 112 and caesium 137?

\_\_\_\_\_

[2 marks]

iv. Circle which of these 4 nuclei drawn are isotopes.

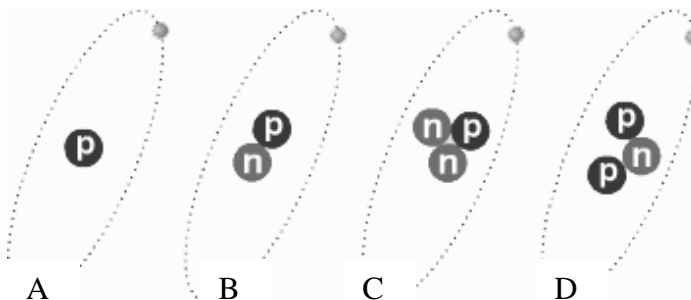

[1 mark]

**5. This question is about electrical components.**

The circuit shows how different components can be tested using an ammeter and voltmeter.

- a. Draw a variable resistor in series with the ammeter. [2 marks]
- b. What is the function of the variable resistor?

\_\_\_\_\_

\_\_\_\_\_

\_\_\_\_\_

[1 mark]

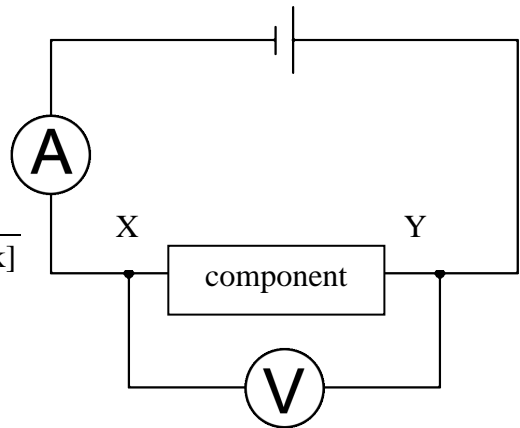

- c. Write down the missing words:

An Ammeter should have a \_\_\_\_\_ resistance and should always be connected in \_\_\_\_\_.

A Voltmeter should have a \_\_\_\_\_ resistance and should always be connected in \_\_\_\_\_.

[4 marks]

- d) Rita found the following components in the laboratory:

<b>a 1.5 A fuse wire</b>	<b>a 2.5 A fuse wire</b>	<b>LDR</b>	<b>a light emitting diode</b>	<b>a filament bulb</b>
--------------------------	--------------------------	------------	-------------------------------	------------------------

- i. Draw the symbols of the following: [3 marks]

Component	Symbol
an LDR	
a light emitting diode	
a filament bulb	

- 
- ii. Explain how the circuit shown could be used to check which of the components is the 2.5 A or the 1.5 A fuse wire.

---

[2 marks]

- iii. What does LED stand for?

---

[1 mark]

- iv. Explain how the circuit shown could be used to check which component is the LED or the filament bulb.

---

[2 marks]

- e. Three other different electrical components J, K and L are placed in turn in the gap XY of the above circuit. For each component a set of different ammeter and voltmeter readings are obtained.

- i. Explain how the resistance of each component can be found.

---

[2 marks]

- ii. One of these components is an Ohmic conductor. Explain the term Ohmic conductor.

---

[1 mark]

- iii. Give an example of an Ohmic conductor.

---

[1 mark]

- iv. Give an example of a Non-Ohmic conductor.

---

[1 mark]

Blank Page