

MATRICULATION AND SECONDARY EDUCATION CERTIFICATE EXAMINATIONS BOARD
UNIVERSITY OF MALTA, MSIDA

SECONDARY EDUCATION CERTIFICATE LEVEL

SEPTEMBER 2016 SESSION

SUBJECT: **Physics**
 PAPER NUMBER: **I**
 DATE: **29th August 2016**
 TIME: **9:00 a.m. to 11:05 a.m.**

Answer all Questions.

You are requested to show your working and to write the units where necessary.

When necessary, take g, acceleration due to gravity, as 10m/s².

Density	$m = \rho V$	
Pressure	$F = p A$	$p = \rho g h$
Moments	Moment = $F \times$ perpendicular distance	
Energy and Work	$PE = m g h$	$KE = \frac{1}{2} m v^2$ $W = F s$
	Work Done = energy converted $E = P t$	
Force and Motion	$m a =$ unbalanced force $W = m g$	$v = u + a t$
	average speed = $\frac{\text{total distance}}{\text{total time}}$	$s = (u + v) \frac{t}{2}$
	$v^2 = u^2 + 2 a s$	$s = u t + \frac{1}{2} a t^2$ momentum = $m v$
Waves	$\eta = \frac{\text{speed of light in air}}{\text{speed of light in medium}}$	$v = f \lambda$
	$\eta = \frac{\text{real depth}}{\text{apparent depth}}$	Magnification = $\frac{\text{image distance}}{\text{object distance}}$
	Magnification = $\frac{\text{image height}}{\text{object height}}$	$T = \frac{1}{f}$
Electricity	$Q = I t$	$V = I R$ $E = Q V$
	$P = I V$	$R \propto \frac{1}{A}$ $E = I V t$
	$R_{\text{total}} = R_1 + R_2 + R_3$	$\frac{1}{R_{\text{total}}} = \frac{1}{R_1} + \frac{1}{R_2}$
Electromagnetism	$\frac{N_p}{N_s} = \frac{V_p}{V_s}$	$V_p I_p = V_s I_s$
Heat	$Q = m c \Delta\theta$	
Radioactivity	$A = Z + N$	
Other equations	Area of a triangle = $\frac{1}{2} b h$	Area of a trapezium = $\frac{1}{2} (a + b) h$
	Area of a circle = πr^2	

1. The figure shows a stainless steel saucepan on a gas burner. Food is being cooked in boiling water in the saucepan.



a. Name the process by which heat is transferred through the saucepan.

_____ [1 mark]

b. Name the process by which the water is being heated.

_____ [1 mark]

c. The figures below show three different ways in which particles in a substance may be arranged.

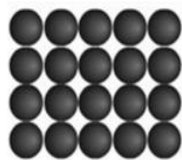

A



B



C

Indicate which figure A, B or C, best represents the arrangement of the particles:

i. In the stainless steel saucepan _____ [1 mark]

ii. In the steam coming out of the saucepan _____ [1 mark]

d. Give one reason why the saucepan is made of stainless steel.

_____ [1 mark]

e. Suggest a suitable material for the handle of the saucepan. Explain your answer.

 _____ [2 marks]

f. Continue the following sentence:

Evaporation can be described as the _____ from the _____.
 _____ [2 marks]

g. A lid is now used to cover the saucepan. Give one reason why the lid is needed.

_____ [1 mark]

2. Sir Isaac Newton deduced that the weight of an object is due to the force of gravity. In August 2012, the Curiosity rover landed on Mars. The rover has a mass of 900 kg. The acceleration due to gravity on Mars is 3.7 m/s^2 .



<http://mars.nasa.gov/msl/mission/rover/>

- a. Find:
 - i. the weight of Curiosity on Earth.

[2 marks]

- ii. the mass of Curiosity on Mars.

[1 mark]

- iii. the weight of Curiosity on Mars.

[1 mark]

- iv. Compare the pressure exerted by Curiosity on Mars and on Earth. Explain.

[2 marks]

b. The Curiosity rover communicates with Earth using radio waves. Radio waves form part of the electromagnetic spectrum.

Name two other parts of the electromagnetic spectrum and give one use for each of them.

[4 marks]

3. A length of resistance wire XY is connected in the circuit shown. When the switch is closed, the current in the circuit is 0.2 A and the p.d. across the wire is 3 V.

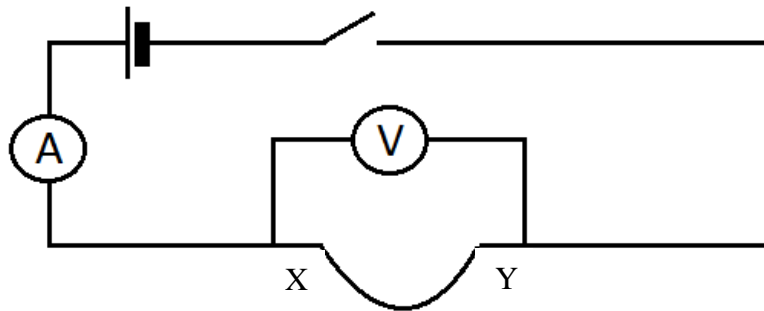

a. What is the resistance of the wire?

[2 marks]

b. What would happen to:

i. the resistance of the wire if the length of the wire is doubled? Explain your answer.

[2 marks]

ii. the current in the circuit if the diameter of the wire is doubled? Explain your answer.

[2 marks]

c. In the space below, sketch a graph to show how the current and voltage vary across the resistance wire.

[2 marks]

d. What can you conclude from the shape of the graph?

[2 marks]

4. Earth forms part of the Milky Way Galaxy. Stars and other stellar bodies may emit light and radio waves.

a. How can these two wave sources be studied from earth?

[2 marks]

b. Estimates show that the distance between two stellar bodies is 100, 000 light years. What is this distance in kilometres, if the speed of light in a vacuum is 3×10^8 m/s?

[3 marks]

c. For planets to orbit the sun in our solar system, a force is required which is provided by the gravitational force. What happens to this force if:

i. the mass of a planet had to be increased;

[1 mark]

ii. the distance of separation between the sun and the planet is increased?

[1 mark]

d. Many people believe that Earth is closer to the sun in the summer and that is why it is hotter. And, likewise, they think Earth is farthest from the sun in the winter.

i. State whether this statement is correct or incorrect.

[1 mark]

ii. Explain how you arrived to your answer in part d(i).

[2 marks]

5. The temperature along a metal rod was measured at equal intervals from one end which was being heated using a Bunsen flame.

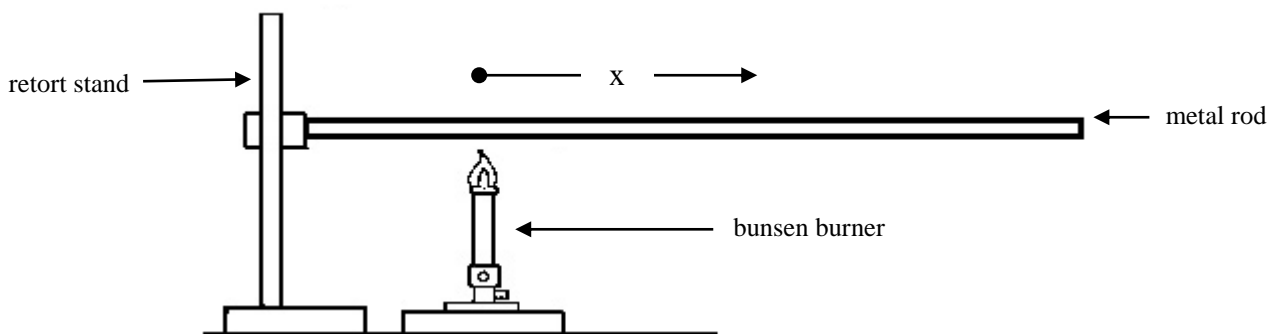

The temperatures measured were recorded in the table below.

Distance (x)/cm	0.0	5.0	10.0	15.0	20.0	25.0
Temperature/ $^{\circ}$ C	160.0	120.0	80.0	40.0	20.0	20.0

- a. Plot a graph of temperature (y-axis) against distance (x-axis). [4 marks]
- b. Determine the gradient of the graph till when the temperature reached 20.0° C.

[2 marks]

- c. What does the shape of the graph show?

[2 marks]

- d. From the graph estimate a possible value for room temperature. Explain how you arrived at your conclusion.

[2 marks]

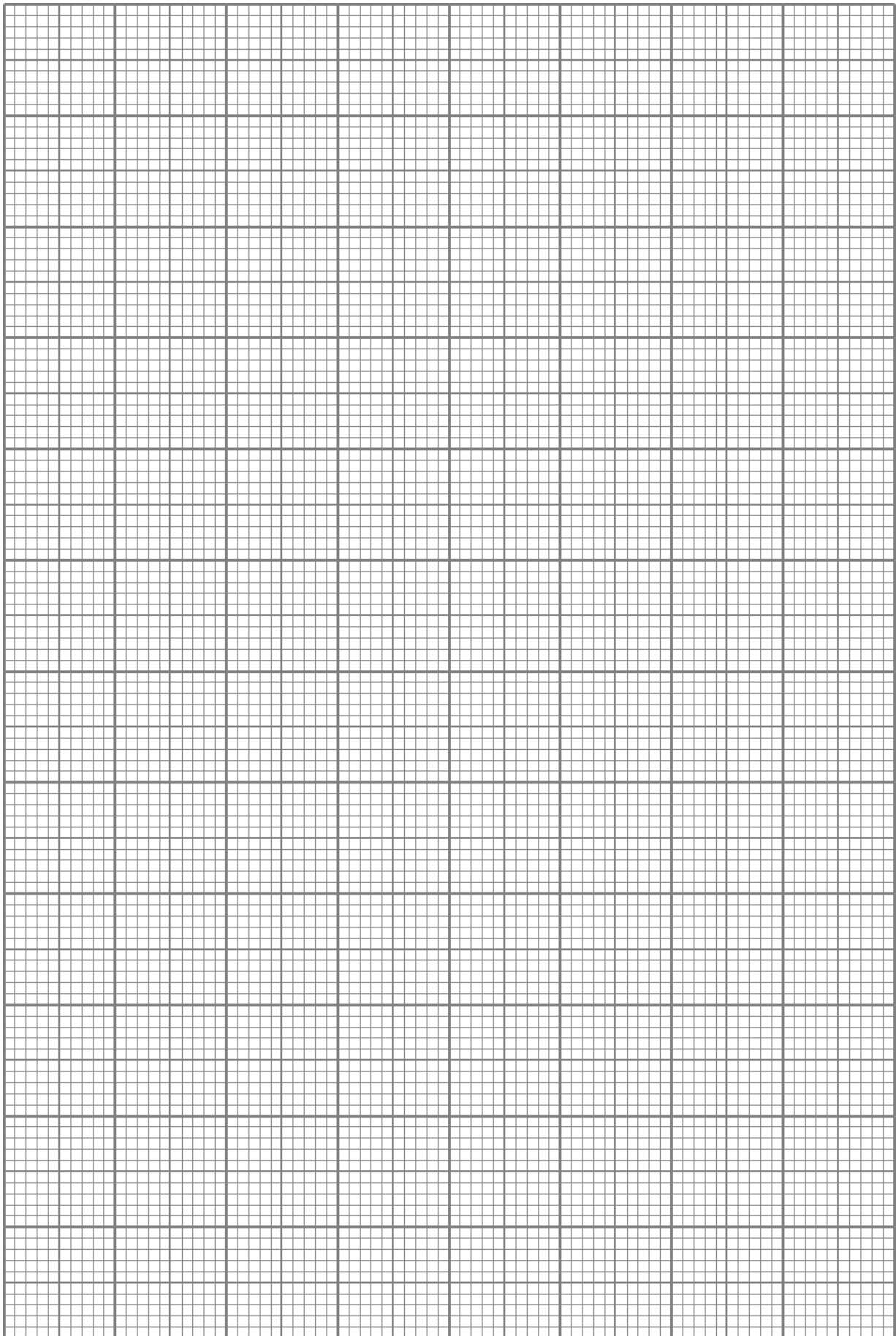

6. During a typical Maltese summer, concrete roofs and walls are exposed to the sun for a large number of hours. They will absorb heat and the temperature inside the house can increase to uncomfortable levels. On the contrary in winter, the temperature inside the house can reach very low levels.

a. Suggest two main precautions that can be taken while building houses in order to reduce the absorption of heat in summer and the heat losses in winter from walls and roofs.

[2 marks]

b. Double-glazed windows reduce heat losses from the house in winter. Explain.

[2 marks]

c. Mention any other method in which we can insulate our houses.

[1 mark]

d. Anne bought a gas heater and placed it in a corner of the living room as shown in the figure below. Add labelled arrows to show how convection currents are heating the room.

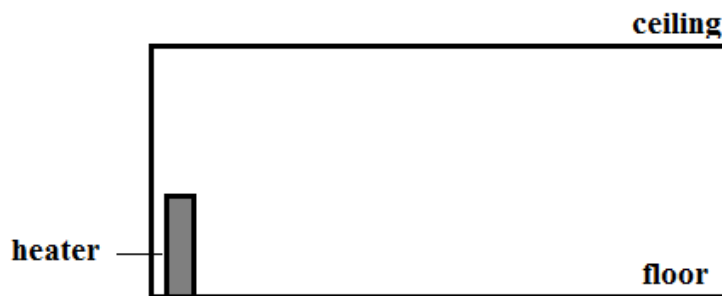

[2 marks]

e. Anne wanted to calculate the amount of energy required to increase the temperature of the room from 8°C to 26°C. She found out that the specific heat capacity of air is approximately 1005.

i. What are the units of specific heat capacity?

[1 mark]

ii. Calculate the energy required if the mass of air in the room is 278.6 kg.

[2 marks]

7. A bus leaves a bus stop and accelerates at 0.5 m/s^2 from rest to reach a speed of 15 m/s . It then travels at this speed for 100 seconds. When it approaches the next stop, the driver applies the brakes uniformly to bring the bus to a stop in 20 seconds.

a. Explain the difference between speed and velocity.

[2 marks]

b. Sketch a velocity-time graph of the bus journey.

[2 marks]

c. Calculate:

i. the time it took the bus to reach its top speed;

[2 marks]

ii. the distance it travelled while at its top speed;

[2 marks]

iii. the acceleration required to bring the bus to a stop.

[2 marks]

8. The Marsa Power station used to depend on the burning of coal. Since it was switched off and put on cold standby in the beginning of 2015 carbon dioxide (CO₂) emissions in the area were reduced by up to 761,000 tonnes a year. (Malta Independent, 21st April 2016)

a. What is the main difference between renewable and non-renewable sources of energy?

[1 mark]

b. State whether coal is a renewable or non-renewable source of energy. Give a reason for your answer.

[2 marks]

c. Mention TWO advantages of using coal as a source of energy.

[2 marks]

d. Mention TWO other fossil fuels.

[1 mark]

e. Nuclear energy is one of the alternatives to fossil fuels. State TWO disadvantages if Malta had to invest in nuclear energy.

[2 marks]

f. The diagram shows a solar mobile phone charger. On average its solar cells produce 2.7 Joules of energy per second. The solar cells have an efficiency of 15%. Calculate the average input power of the solar cells.



[2 marks]

9.a. By means of a diagram, distinguish between a transverse wave and a longitudinal wave.

[2 marks]

b. The graph below represents an object oscillating up and down about a fixed point.

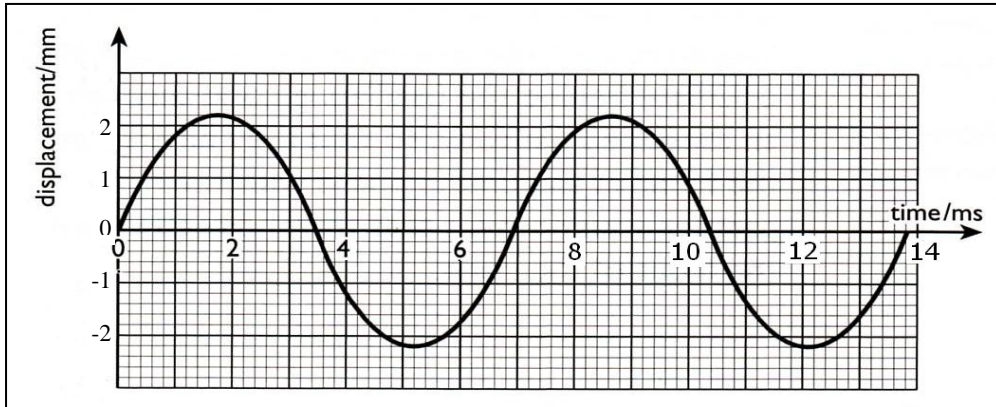

i. What is the amplitude of the oscillating object?

[1 mark]

ii. What is the periodic time of the oscillating object?

[2 marks]

iii. Calculate the frequency of the oscillating object.

[2 marks]

c. A wave has a wavelength of 25 mm and a frequency of 3 Hz.

i. Calculate the velocity of this wave.

[2 marks]

ii. Show by means of a diagram, what it means to say that a wave ‘dies out’.

[1 mark]

10. a. The diagram below shows a light signal travelling through an optical fibre made of solid glass.

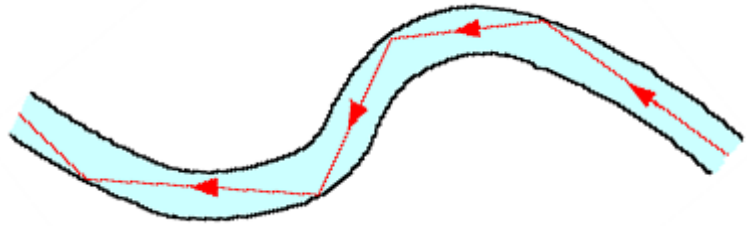

i. State **TWO** changes that happened to the light when it passed from air into the glass fibre.

[2 marks]

ii. Explain why light does not escape out of the optical fibre.

[2 marks]

iii. Circle the correct word for the effect shown in the above diagram.

Total internal reflection

Diffraction

Total external reflection

[1 mark]

iv. Optic fibres are used locally for internet communications. Name ONE advantage that optic fibres have for this use.

[1 mark]

b. Fishermen use pulses of sound to measure the depth of fish beneath the fishing boat. The sound pulses are reflected from the fish and return to the boat.

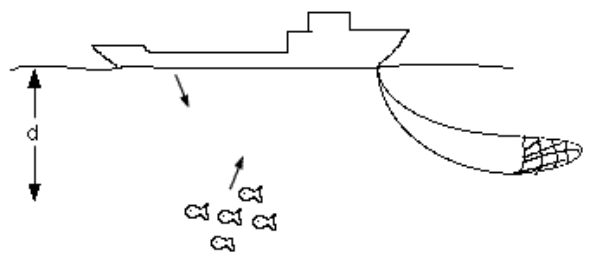

i. The speed of sound in sea water is 1500 m/s and the time taken for the sound pulse to return to the boat is 0.2 s. Calculate the depth of the shoal of fish.

[2 marks]

ii. Suggest ONE reason why there may be a second weak returning pulse.

[2 marks]

MATRICULATION AND SECONDARY EDUCATION CERTIFICATE EXAMINATIONS BOARD
UNIVERSITY OF MALTA, MSIDA

SECONDARY EDUCATION CERTIFICATE LEVEL

SEPTEMBER 2016 SESSION

SUBJECT:	Physics
PAPER NUMBER:	IIB
DATE:	29th August 2016
TIME:	4:00 p.m. to 6:05 p.m.

Answer all Questions.

You are requested to show your working and to write the units where necessary.

When necessary, take g, acceleration due to gravity, as 10m/s².

Density	$m = \rho V$	
Pressure	$F = p A$	$p = \rho g h$
Moments	Moment = $F \times$ perpendicular distance	
Energy and Work	$PE = m g h$	$KE = \frac{1}{2} m v^2$
	$W = F s$	Work Done = energy converted
Force and Motion	$E = P t$	
	$m a =$ unbalanced force	$W = m g$
	$v = u + a t$	average speed = $\frac{\text{total distance}}{\text{total time}}$
Waves	$s = (u + v) \frac{t}{2}$	$v^2 = u^2 + 2 a s$
	$s = u t + \frac{1}{2} a t^2$	momentum = $m v$
	$\eta = \frac{\text{speed of light in air}}{\text{speed of light in medium}}$	$v = f \lambda$
Electricity	$\eta = \frac{\text{real depth}}{\text{apparent depth}}$	Magnification = $\frac{\text{image distance}}{\text{object distance}}$
	Magnification = $\frac{\text{image height}}{\text{object height}}$	$T = \frac{1}{f}$
	$Q = I t$	$V = I R$
Electromagnetism	$E = Q V$	$P = I V$
	$R \propto \frac{1}{A}$	$E = I V t$
	$R_{\text{total}} = R_1 + R_2 + R_3$	$\frac{1}{R_{\text{total}}} = \frac{1}{R_1} + \frac{1}{R_2}$
Heat	$\frac{N_p}{N_s} = \frac{V_p}{V_s}$	$V_p I_p = V_s I_s$
Radioactivity	$Q = m c \Delta\theta$	
Other equations	$A = Z + N$	
	Area of a triangle = $\frac{1}{2} b h$	Area of a trapezium = $\frac{1}{2} (a + b) h$
	Area of a circle = πr^2	

1. *This question is about electrical energy.*

- a. Jake wanted to find the energy consumption of a tungsten filament lamp rated at 100 W. If Jake needs to use the bulb for 3 hours a day, how much energy is supplied in a week?

[2 marks]

- b. Jake wanted to test whether an energy saving lamp rated at 15 W is more efficient than the bulb stated in part (a).

- i. Calculate the energy supplied to this type of bulb in a week.

[2 marks]

- ii. What is the difference in the amount of energy used by the two lamps?

[2 marks]

- iii. Why do tungsten filament lamps use much more energy than energy saving lamps to give out the same amount of light?

[2 marks]

- iv. State TWO reasons why Jake should buy the energy saving lamp.

[2 marks]

c. Ruth sets up the following circuit.

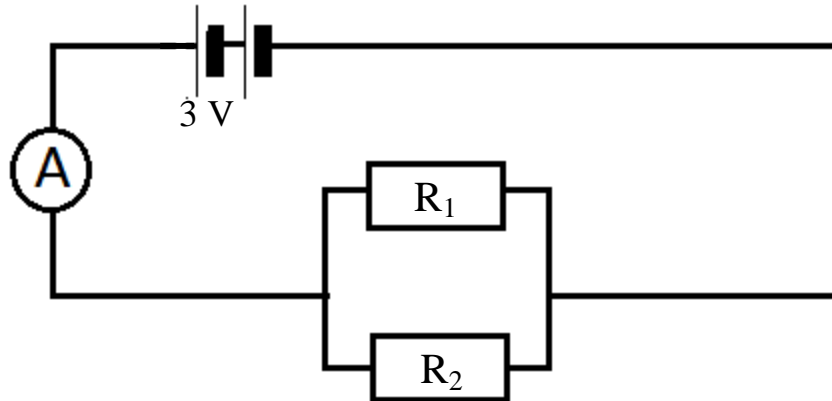

i. If $R_1 = 75 \Omega$ and $R_2 = 150 \Omega$, what is the total resistance of the parallel branch?

[2 marks]

ii. Calculate the current recorded by the ammeter.

[2 marks]

iii. What is the p.d across the parallel branch?

[2 marks]

iv. If another resistor had to be included in the circuit in series with the parallel branch, explain, giving a reason what would happened to:

- the total current in the circuit?

[2 marks]

- the p.d. across the parallel branch?

[2 marks]

2. *This question is about radioactivity.*

a. ${}_{92}^{232}\text{U}$ is an isotope which is suspected to give off radioactive radiation.

i. Complete the following table for a neutral atom of ${}_{92}^{232}\text{U}$.

<i>Number of protons</i>	
<i>Number of neutrons</i>	
<i>Number of electrons</i>	

[3 marks]

ii. Fill in the following table for the three possible types of radiation emitted.

Name of radiation	Nature of radiation
<i>Alpha</i>	
<i>Beta</i>	
<i>Gamma</i>	

[3 marks]

iii. Which radiation will find it difficult to pass through paper?

_____ [1 mark]

iv. Which radiation cannot be deflected by an electric or magnetic field?

_____ [1 mark]

v. Which radiation is the most ionising?

_____ [1 mark]

vi. Which radiation passes through paper but can be stopped a sheet of aluminium?

_____ [1 mark]

vii. What is background radiation? Mention ONE possible source.

[2 marks]

b. A radioactive source has an activity of 200 counts/s. It is known to have a half-life of 4 minutes.

i. What is the meaning of half-life?

[2 marks]

ii. What would the count rate be after 4 minutes?

[1 mark]

iii. After what time would the count rate fall to 25 counts/s?

[2 marks]

iv. In spite of the dangers, radioactive isotopes have many useful applications. Mention ONE such use in industry and clearly explain this application.

[3 marks]

3. This question is about forces and pressure.

- a. The figure below shows a simple hydraulic machine. A number of masses can be placed on piston A. Piston B is attached to a compressible spring, which in turn is attached to a fixed support.

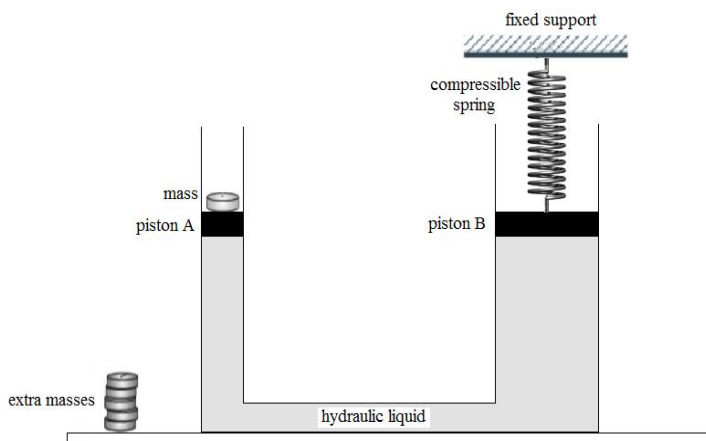

- i. Draw an arrow on the figure above to show the force acting on piston A when a mass is placed on it. [1 mark]
- ii. Draw an arrow on the figure above to show the force acting on piston B when the mass is placed on piston A. [1 mark]
- iii. The student measures the diameter of piston A and piston B. Explain how the student can find the area of the two separate pistons.

[2 marks]

- b. The student reads some information about hydraulic machines and finds the statement below.

- i. Fill in the blanks.

The _____ on piston A is _____ to the pressure on piston B, as it is _____ equally through the _____.

[2 marks]

- ii. The student decides to investigate the statement in part (i) by placing different masses on piston A and then measuring the compression in the spring attached to piston B. He realises that a metre ruler, a pointer, a stand and a clamp are required. Include this apparatus with the diagram and label it clearly.

[2 marks]

- iii. Put the following statements in order by using the numbers **1** to **7**, to describe the method that the student should follow to investigate the statement in part(i). The first one is done for you.

[3 marks]

He places a mass on piston A and finds the force acting by using $W = mg$.	
He records the new position of piston B using the pointer on the ruler and calculates the compression.	
The diameter of both pistons is measured and their cross-sectional area is calculated.	1
He repeats this procedure using several masses to investigate if the statement is true for all forces applied at A.	
Given that the spring compresses by 0.5 mm for every 1.0 N of applied force, he can calculate the force on piston B.	
He records the original position of piston B using the pointer and ruler.	
The pressure on both pistons can be calculated by using $P = F/A$.	

c. Given that a mass of 100 g is placed on piston A, calculate the force acting on piston A.

[2 marks]

d. The area of piston A is 0.00126 m^2 . Calculate the pressure on piston A.

[2 marks]

e. State the value of the pressure on piston B.

[1 mark]

f. Given that the area of piston B is 0.01540 m^2 , calculate the force acting at piston B.

[2 marks]

g. If the spring used can compress by 0.5 mm for every 1.0 N, calculate the compression of the spring in **mm**.

[2 marks]

4. This question is about electromagnetism.

a. The diagram below shows a simple motor. It consists of a loop of conducting wire ABCD placed inside the magnetic field of two magnets. As the power supply is switched on, the loop ABCD is seen to rotate.

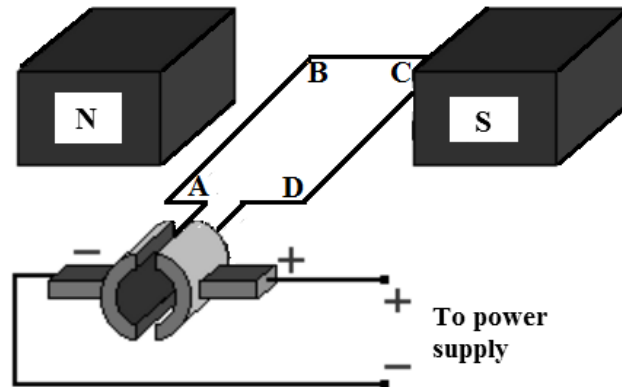

i. Draw arrows in ABCD to show the direction of the current when the power supply is switched on. [2 marks]

ii. Draw arrows between the two magnets to show the magnetic field. [2 marks]

iii. Why does the loop of wire start rotating?

[1 mark]

iv. Use Fleming's left hand rule to state if the loop ABCD will rotate clockwise or anti-clockwise, when the supply is switched on.

[1 mark]

v. State TWO changes that can be done to make the loop rotate faster.

[2 marks]

vi. State ONE practical use of the simple motor.

[1 mark]

b. The diagram shows a solenoid connected to a galvanometer. As the magnet is moved towards the solenoid as shown, the galvanometer shows a deflection towards the right.

i. Circle the correct answer from the brackets.

The pole induced at A is (North/South) and the pole induced at B is (North / South).

[2 marks]

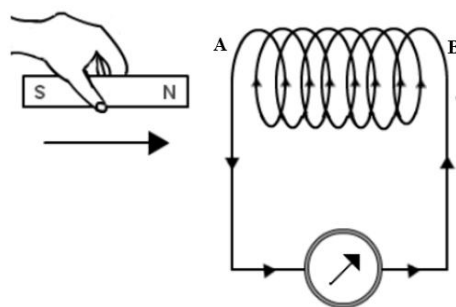

[1 mark]

iii. Why is current induced in the solenoid?

[1 mark]

iv. What happens when the magnet is at rest inside the solenoid? Explain.

[2 marks]

v. State what would be observed on the galvanometer while the magnet is being pulled out of the solenoid.

[1 mark]

vi. What does this indicate about the current through the solenoid?

[1 mark]

vii. If the magnet is pulled out faster, the galvanometer shows a bigger deflection. What does this indicate about the current?

[1 mark]

viii. Fill in the blanks:

The law applied in (vii) is _____'s Law. It states that the _____ induced in a conductor is _____ to the rate at which the _____ are being cut by the conductor.

[2 marks]

5. This question is about personal power.

a. Work is done when a person goes up the stairs. A number of students investigate how the power generated changes with the weight of a student when going up a set of stairs.

i. Name the instrument used to measure the:

- height of each step : _____
- time for the student to run up the stairs: _____
- weight of the student: _____

[3 marks]

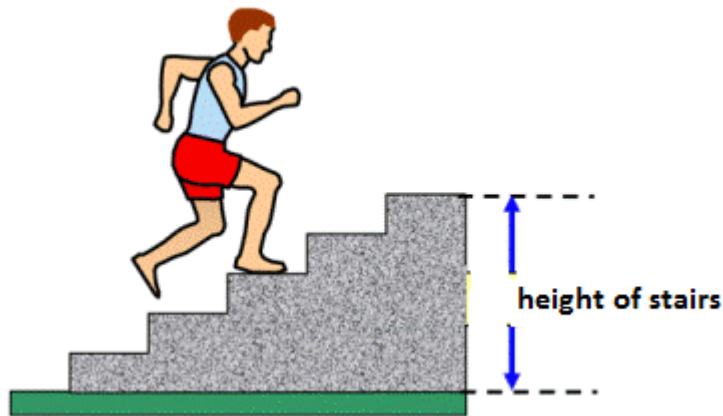

ii. Use the diagram given to explain how to measure the power of a student running up the stairs.

[4 marks]

iii. Name TWO precautions taken during this experiment.

[2 marks]

-
- iv. Would a man with a mass of 60 kg exert a larger force on the stairs than someone with a mass of 90 kg?

[1 mark]

- v. If the two men were to run up the stairs at the same time, explain who will develop more power.

[2 marks]

- b. A student weighs 450 N. He runs up the stairs in 6 s. Each step is 20 cm high and there are 30 steps. Calculate :

- i. the total height of the stairs.

[1 mark]

- ii. the work done in climbing the steps.

[2 marks]

- iii. the power the student develops when running up the steps.

[2 marks]

- iv. the potential energy of the student after climbing the stairs.

[1 mark]

- c. The student grabs a ball and drops it vertically from the highest step to the ground. Assuming that air resistance is negligible calculate the velocity of the ball as it touches the ground.

[2 marks]

Blank Page