



SUBJECT:	<b>Physics</b>
PAPER NUMBER:	I
DATE:	19 <sup>th</sup> September 2020
TIME:	9:00 a.m. to 11:05 a.m.

**Answer ALL questions.**

**You are requested to show your working and to write the units where necessary.**

**When necessary, take g, acceleration due to gravity, as 10 m/s<sup>2</sup>.**

<b>Density</b>	$m = \rho V$	
<b>Pressure</b>	$F = p A$	$p = \rho g h$
<b>Moments</b>	Moment = F × perpendicular distance	
<b>Energy and Work</b>	$PE = m g h$	$KE = \frac{1}{2} m v^2$
	$W = F s$	
<b>Force and Motion</b>	Work Done = energy converted	
	$E = P t$	
	$m a = \text{unbalanced force}$	$W = m g$
<b>Force and Motion</b>	$v = u + a t$	
	average speed = $\frac{\text{total distance}}{\text{total time}}$	$s = (u + v) \frac{t}{2}$
	$v^2 = u^2 + 2 a s$	$s = u t + \frac{1}{2} a t^2$
<b>Waves</b>	momentum = $m v$	
	$\eta = \frac{\text{speed of light in air}}{\text{speed of light in medium}}$	$v = f \lambda$
	$\eta = \frac{\text{real depth}}{\text{apparent depth}}$	Magnification = $\frac{\text{image distance}}{\text{object distance}}$
<b>Electricity</b>	Magnification = $\frac{\text{image height}}{\text{object height}}$	
	$T = \frac{1}{f}$	
	$Q = I t$	$V = I R$
<b>Electricity</b>	$E = Q V$	
	$P = I V$	$R \propto \frac{L}{A}$
	$E = I V t$	
<b>Electricity</b>	$R_{\text{total}} = R_1 + R_2 + R_3$	$\frac{1}{R_{\text{total}}} = \frac{1}{R_1} + \frac{1}{R_2}$
	$\frac{V_p}{V_s} = \frac{N_p}{N_s}$	$V_p I_p = V_s I_s$
<b>Electromagnetism</b>		
<b>Heat</b>	$Q = m c \Delta \theta$	
<b>Radioactivity</b>	$A = Z + N$	
<b>Other equations</b>	Area of a triangle = $\frac{1}{2} b h$	Area of a trapezium = $\frac{1}{2} (a + b) h$
	Area of a circle = $\pi r^2$	

1a. The diagram shows a boy with his right foot and right shoulder touching a wall. The centre of gravity of the boy lies in the middle of the body as shown.

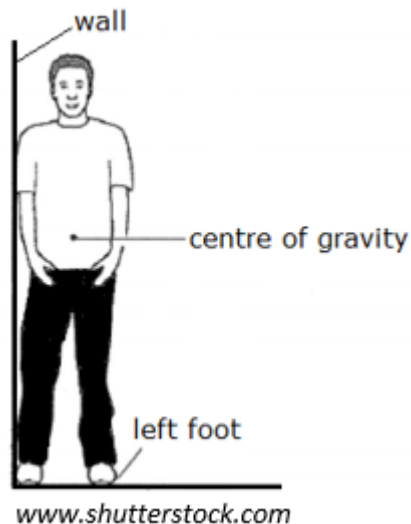

i. Explain 'centre of gravity'.

\_\_\_\_\_ (1)

ii. State what happens to the boy if he lifts up his left foot but leaves his right shoulder touching the wall.

\_\_\_\_\_ (2)

iii. Give a reason to your answer in part (ii).

\_\_\_\_\_ (1)

iv. Will the same reaction occur if the boy had to lift up his right foot instead?

\_\_\_\_\_ (1)

b. Weightlifting is a sport where force and stability are important. The diagram shows a sportsman of mass 80 kg lifting up weights.

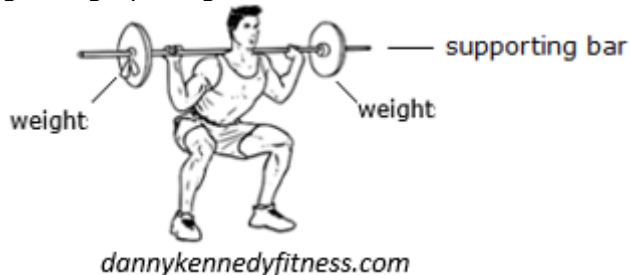

i. With reference to the diagram explain **TWO** features that help increase the weightlifter's stability as he lifts up the weights.

\_\_\_\_\_ (2)

ii. Give a possible reason why it is easier to carry the weight if the centre of gravity of the weights is just behind his neck.

\_\_\_\_\_ (1)

iii. Calculate the total weight acting on the floor if each weight has a mass of 100 kg and the supporting bar has a mass of 20 kg.

\_\_\_\_\_ (2)

**(Total: 10 marks)**

---

2. On the 26<sup>th</sup> November 2011, NASA launched the Alliance Atlas V, containing the Curiosity Rover with the aim to explore the planetary surface of Mars. The rocket at full thrust delivers a resultant force of around  $1 \times 10^7$  N.

a. Calculate the acceleration of the rocket if the mass of the rocket is approximately 590000 kg.

---

---

---

(2)

b. In order for the rocket to escape from the gravitational pull of the Earth, it had to reach the velocity of at least 11,000 m/s. Calculate the time taken for the rocket to reach this velocity if the rocket starts from rest.

---

---

---

(2)

The rocket reached the outer atmosphere of Mars on the 6<sup>th</sup> August 2012, where it released the 900 kg Martian Rover for descent. The rover used parachutes and guided rockets to help it land on the surface of Mars.

c. If the gravitational acceleration on Mars is  $3.7 \text{ m/s}^2$ , calculate the weight of the rover on Mars.

---

---

(2)

d. Before the release of the parachute, the rover was travelling at 820 m/s. The parachute manages to reduce the velocity of the rover to 110 m/s in a distance of 10 km. Calculate the deceleration of the rover.

---

---

---

(3)

e. How does a parachute manage to decrease the velocity during free fall?

---

---

(1)

**(Total: 10 marks)**

3. The diagram below shows a Newton spring balance to which a metal block P has been attached.

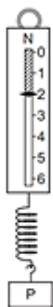

<http://vbio.weebly.com>

- a. On the diagram name and label the **TWO** forces acting on the metal block P. (2)  
 b. Calculate the mass of the metal block P, if the weight recorded by the spring balance is 2 N.

\_\_\_\_\_ (2)

- c. Load P was removed, and another load Q was attached to the spring balance as shown below. It was noticed that the spring balance now extended to 3N.

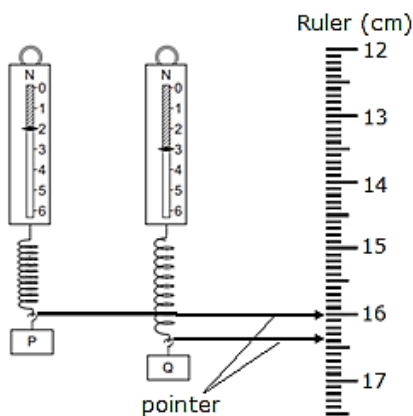

<http://vbio.weebly.com>

- i. Calculate the extra extension experienced by the spring when Q is attached instead of P.

(1)

- ii. What will the reading of the pointer be if no load is attached to the spring balance?

(2)

- iii. Calculate the new reading of the pointer if both loads Q and P are hung together to the spring.

(2)

- iv. State the law used to calculate your answers above.

(1)

**(Total: 10 marks)**

4. The diagram shows a 50 cm uniform mechanical arm, that has a load of 4 N attached to its end. The piston, located at the centre of the mechanical arm, keeps air particles trapped inside a cylinder.

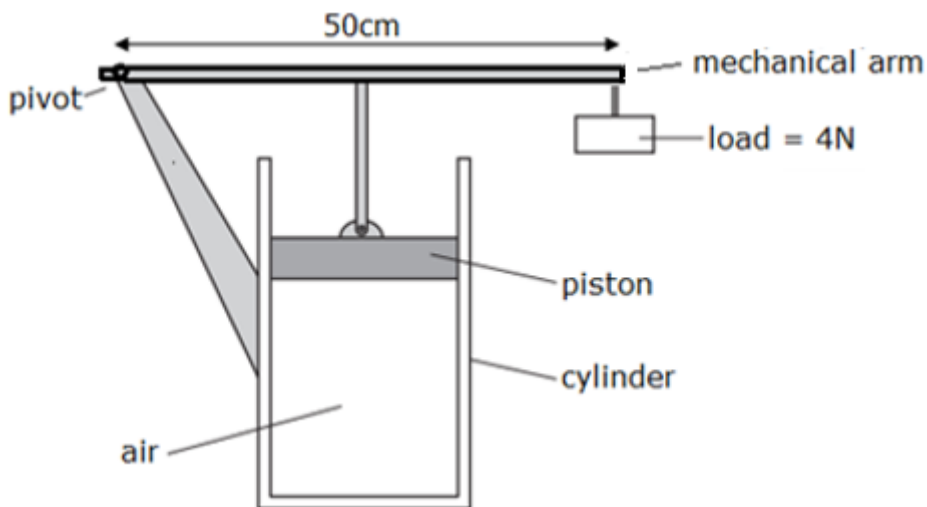

- a. Describe the movement of the air particles inside the container.

\_\_\_\_\_ (1)

- b. The system is in equilibrium. Calculate the force exerted by the air particles on the piston.

\_\_\_\_\_ (2)

- c. The piston has a cross-sectional area of  $0.01 \text{ m}^2$ . Calculate the pressure exerted by the air particles on the piston.

\_\_\_\_\_ (2)

- d. The air inside the cylinder is heated but the system remains in equilibrium.

- i. State the changes, if any, in the following quantities:

Pressure of air inside cylinder \_\_\_\_\_  
 Volume of air in the cylinder \_\_\_\_\_  
 Density of air in cylinder \_\_\_\_\_ (3)

- ii. More heat is supplied until the piston moves upwards. Mention **TWO** ways how equilibrium can be restored in the system above.

\_\_\_\_\_ (2)

**(Total: 10 marks)**

5. The diagram below shows a circuit where different resistances are connected between A and B and the current is recorded from the ammeter in each case. The battery voltage is kept constant throughout the whole procedure.

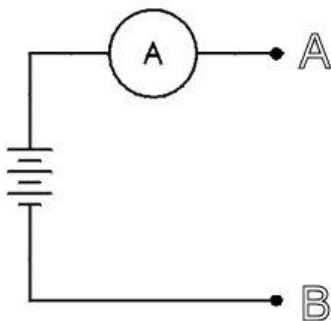

The following results were obtained:

Resistance between AB ( $\Omega$ )	Current (A)
1.0	5.00
2.0	2.50
4.0	1.25
8.0	0.63
10.0	0.50
15.0	0.33

- a. Choose **ONE** set of values from the table and calculate the potential difference between A and B.

\_\_\_\_\_ (2)

- b. Plot a graph of current on the y-axis against resistance on the x-axis and draw a smooth curve through the plotted points. (5)

- c. From the graph find the reading of current when the resistance is  $6.0 \Omega$ . Record your answer below.

\_\_\_\_\_ (1)

- d. When there is an  $8.0 \Omega$  resistance connected between A and B, a further resistance is added to the circuit and the ammeter then reads 1.5 A. Explain clearly how such an increase in current is possible. The value of the added resistance is not expected.

\_\_\_\_\_  
 \_\_\_\_\_  
 \_\_\_\_\_ (2)

**(Total: 10 marks)**

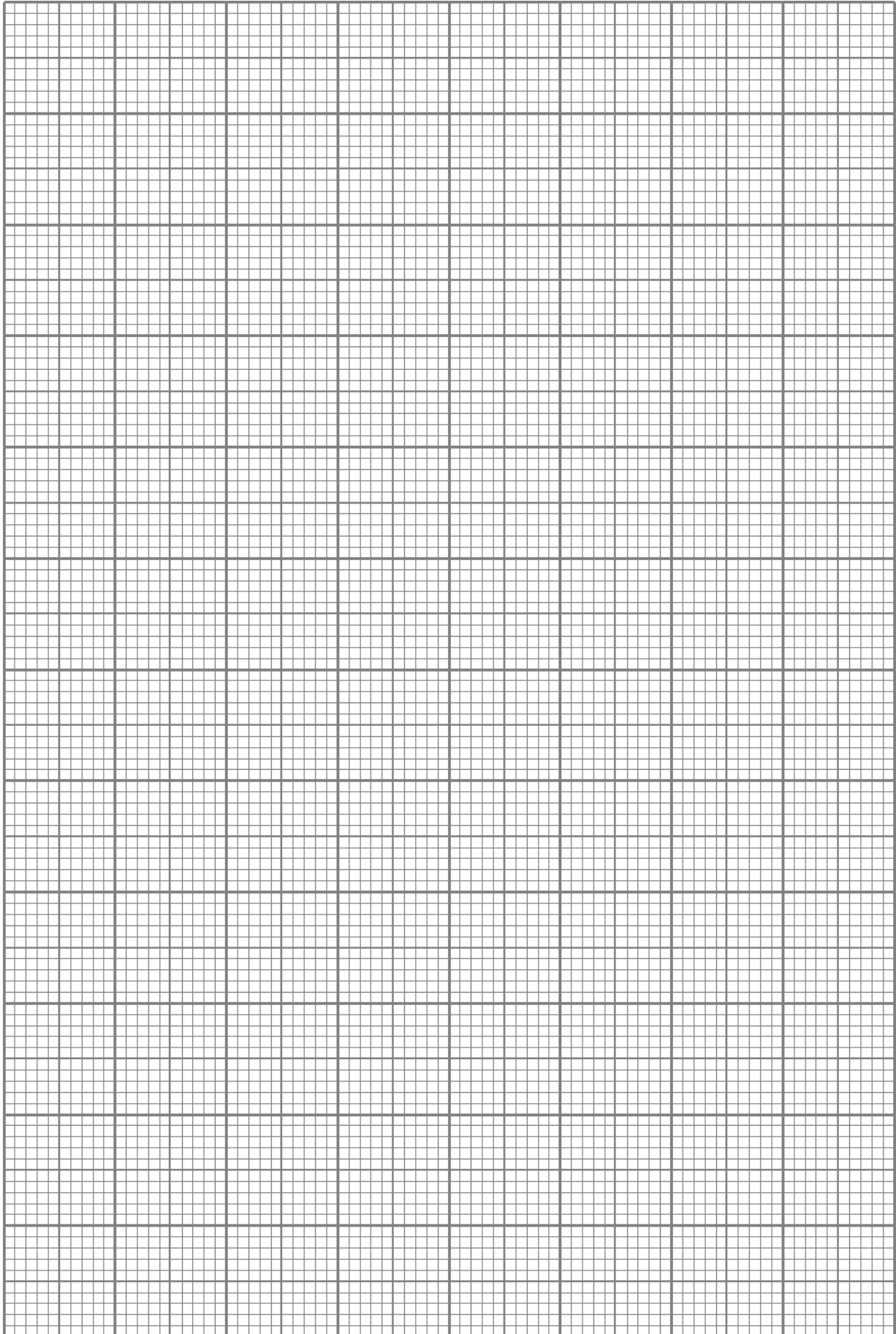

6. The diagram shows a mass in orbit around the Sun.

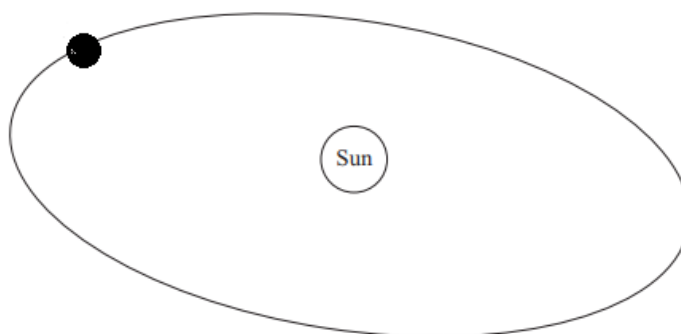

a. Which **ONE** of the following is the mass most likely to be? Underline the correct answer.

- Satellite                  Comet                  Planet                  Star

(1)

b. List **THREE** characteristics of this mass orbiting the Sun.

\_\_\_\_\_

\_\_\_\_\_

\_\_\_\_\_ (3)

c. i. Name the force that keeps the object in orbit around the Sun.

\_\_\_\_\_ (1)

ii. How would this force change, if the mass of the object had to double.

\_\_\_\_\_ (1)

d. The Moon orbits the Earth in an almost circular path. Complete these statements by filling in the missing blanks.

i. The Moon is a natural \_\_\_\_\_ of the Earth. (1)

ii. The Moon's speed of orbit is constant but its velocity changes. This indicates that speed is a \_\_\_\_\_ quantity whereas velocity is a \_\_\_\_\_ quantity. (2)

iii. An astronaut returns from the Moon back to Earth. *Underline the correct statement.*

- The astronaut's mass is larger on Earth than on the Moon
- The astronaut has the same mass on Earth as on the Moon.
- The astronaut has a smaller weight on Earth than on the Moon.
- The astronaut has the same weight on Earth as on the Moon. (1)

**(Total: 10 marks)**



7. Wireless technology can use both 4G and 5G for network transmission. Both use a type of electromagnetic wave to transmit energy, but the difference lies in the frequency used. 4G uses frequencies ranging from 1 GHz to 6 GHz while 5G networks use frequencies that can go up to 100 GHz.  
(1 GHz =  $1 \times 10^9$  Hz)

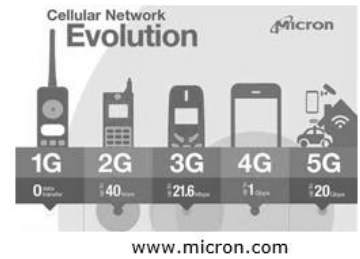

a. Are electromagnetic waves transverse or longitudinal waves?

\_\_\_\_\_ (1)

b. Define the term frequency.

\_\_\_\_\_ (1)

c. By looking at the representation below, which part of the electromagnetic spectrum do 5G network use?

\_\_\_\_\_ (1)

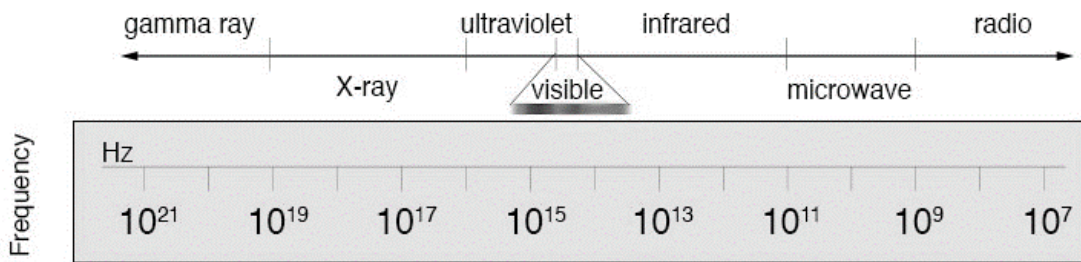

d. Calculate the wavelength of the 100 GHz, 5G network, if the speed of electromagnetic waves is  $3 \times 10^8$  m/s.

\_\_\_\_\_  
 \_\_\_\_\_  
 \_\_\_\_\_ (3)

e. In the table below, list a use for each of the given electromagnetic wave. (4)

Type of wave	Use
Gamma rays	
X-ray	
Ultraviolet	
Infrared	

(Total: 10 marks)

8. A car of mass 1540 kg collides head-on with a large lorry of mass 5600 kg. The car was moving at a velocity of 65 km/hr while the lorry was moving in the opposite direction at a velocity of 5 m/s.

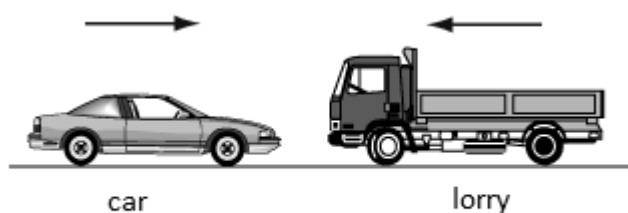

<http://www.hk-phy.org/>

a. Convert 65 km/hr to m/s.

\_\_\_\_\_

\_\_\_\_\_

\_\_\_\_\_ (1)

b. Calculate the momentum of car before collision.

\_\_\_\_\_

\_\_\_\_\_

\_\_\_\_\_ (2)

c. Calculate the momentum of the large lorry before collision considering that it was moving in the opposite direction.

\_\_\_\_\_

\_\_\_\_\_

\_\_\_\_\_ (2)

d. What is the total momentum after collision?

\_\_\_\_\_ (1)

e. After collision the lorry and car move together. Calculate their common velocity after velocity.

\_\_\_\_\_

\_\_\_\_\_

\_\_\_\_\_ (2)

f. Using your answer in part (e) deduce the direction in which the lorry and car will move after collision and explain why they move in this direction.

\_\_\_\_\_

\_\_\_\_\_

\_\_\_\_\_ (2)

**(Total: 10 marks)**

9. A teacher sets up a metal water tank with 15 kg of water at a temperature of 21 °C, to explain plate tectonics, which describe the movement of the Earth’s continents. Two blocks of polystyrene float on top. The polystyrene blocks do not move.

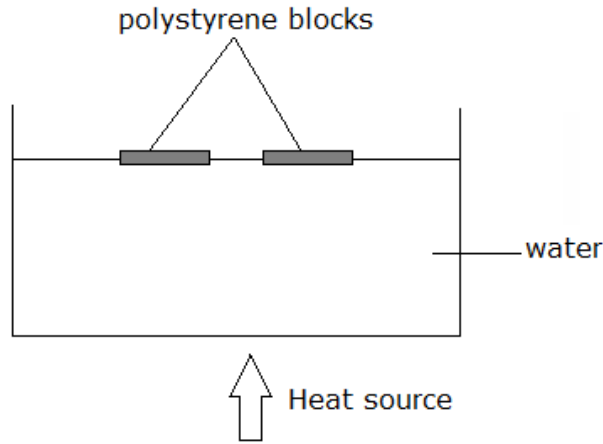

The water tank is placed on an electric hot plate and the heat is turned on.

- a. By which process is the heat transferred through the water. \_\_\_\_\_ (1)
- b. Explain, in terms of the density of water, how this process happens. \_\_\_\_\_ (2)
- c. The polystyrene blocks start moving. In which direction do they move? \_\_\_\_\_ (1)
- d. The hotplate has a power rating of 8190 W and is left on for 5 minutes. Calculate the energy supplied to the water. \_\_\_\_\_ (2)
- e. Calculate the final temperature of the water, if water has a specific heat capacity of 4200 J/kg°C. \_\_\_\_\_ (3)
- f. In order to verify their answer, the students measured the final temperature of water. They found it to be lower than that calculated above. Give **ONE** reason for this difference. \_\_\_\_\_ (1)

(Total: 10 marks)

10. The thyroid is a gland found at the lower part of the neck.

a. Two isotopes of iodine,  $^{131}_{53}\text{I}$  and  $^{123}_{53}\text{I}$ , are used in Mater Dei Hospital as radioactive tracers to diagnose thyroid problems and also in the treatment of cancerous growths in this gland.

i. What do we mean when we say these two elements are isotopes?

\_\_\_\_\_ (2)

ii. Which of these two isotopes has the nucleus with the greater mass? Explain.

\_\_\_\_\_ (2)

b.  $^{131}_{53}\text{I}$  has a half-life of 8 days and decays emitting mostly  $\beta$  radiation together with  $\gamma$  radiation, while  $^{123}_{53}\text{I}$  has a half-life of 13 hours and decays emitting only  $\gamma$  radiation.

i. State **TWO** differences between  $\beta$  and  $\gamma$  radiation.

\_\_\_\_\_ (2)

ii.  $^{131}_{53}\text{I}$  is likely to do more damage to body tissues than  $^{123}_{53}\text{I}$ . Give **TWO** reasons why this is so.

\_\_\_\_\_ (2)

c. Because of their short half-life, such radioactive isotopes are not kept in stock at the hospital like other medicines but are delivered a short time before they are needed from a nuclear medical facility overseas where they are produced. This is done to minimise the amount decaying during storage. In the case of  $^{123}_{53}\text{I}$ , explain why 4 times the required amount needs to leave the overseas facility so that the correct required amount arrives and is ready at the hospital for the procedure 26 hours later.

\_\_\_\_\_  
\_\_\_\_\_  
\_\_\_\_\_ (2)

**(Total: 10 marks)**



SUBJECT:	<b>Physics</b>
PAPER NUMBER:	IIA
DATE:	19 <sup>th</sup> September 2020
TIME:	4:00 p.m. to 6:05 p.m.

**Answer ALL questions.**

**You are requested to show your working and to write the units where necessary.  
When necessary, take  $g$ , acceleration due to gravity, as  $10\text{m/s}^2$ .**

<b>Density</b>	$m = \rho V$
<b>Pressure</b>	$F = p A$ $p = \rho g h$
<b>Moments</b>	Moment = $F \times$ perpendicular distance
<b>Energy and Work</b>	$PE = m g h$ $KE = \frac{1}{2} m v^2$ $W = F s$
	Work Done=energy converted $E=P t$
<b>Force and Motion</b>	$m a =$ unbalanced force $W = m g$ $v = u + a t$
	average speed = $\frac{\text{total distance}}{\text{total time}}$ $s = (u + v) \frac{t}{2}$
	$v^2 = u^2 + 2 a s$ $s = u t + \frac{1}{2} a t^2$ momentum = $m v$
<b>Waves</b>	$\eta = \frac{\text{speed of light in air}}{\text{speed of light in medium}}$ $v = f \lambda$
	$\eta = \frac{\text{real depth}}{\text{apparent depth}}$ Magnification = $\frac{\text{image distance}}{\text{object distance}}$
	Magnification = $\frac{\text{image height}}{\text{object height}}$ $T = \frac{1}{f}$
<b>Electricity</b>	$Q = I t$ $V = I R$ $E = Q V$
	$P = I V$ $R \propto \frac{L}{A}$ $E = I V t$
	$R_{\text{total}} = R_1 + R_2 + R_3$ $\frac{1}{R_{\text{total}}} = \frac{1}{R_1} + \frac{1}{R_2}$
<b>Electromagnetism</b>	$\frac{V_p}{V_s} = \frac{N_p}{N_s}$ $V_p I_p = V_s I_s$
<b>Heat</b>	$Q = m c \Delta\theta$
<b>Radioactivity</b>	$A = Z + N$
<b>Other equations</b>	Area of a triangle = $\frac{1}{2} b h$ Area of a trapezium = $\frac{1}{2} (a + b) h$
	Area of a circle = $\pi r^2$

1. Andrea and Melvin want to investigate the relationship between the energy lost on a bounce of different balls. They set up the apparatus as shown in the diagram and decided to use three different balls (tennis ball, ping pong and golf ball).

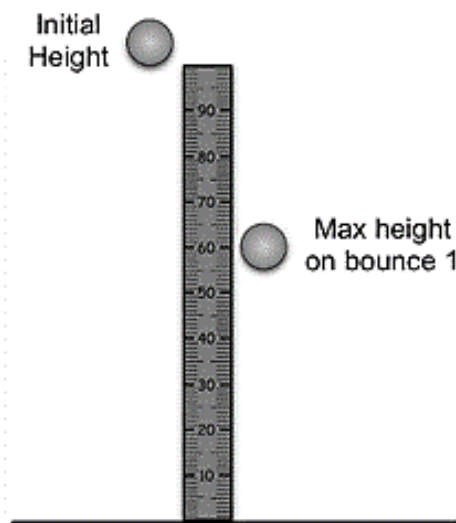

- a. List the energy changes taking place as the ball is released until it hits the ground. (3)

→  +

- b. Describe how they should carry out the experiment.

\_\_\_\_\_  
\_\_\_\_\_  
\_\_\_\_\_  
\_\_\_\_\_ (3)

- c. Determine the initial potential energy of the tennis ball if it is released from a height of 1 m and has a mass of 60 g.

\_\_\_\_\_  
\_\_\_\_\_ (3)

- d. Calculate the final velocity of the ball just before it hits the ground.

\_\_\_\_\_  
\_\_\_\_\_ (2)

---

e. State the law used to work out the previous question.

---

---

---

(2)

f. After it hits the ground the tennis ball reaches a height of 56 cm. Calculate the potential energy of the tennis ball after it hits the ground.

---

---

---

(2)

g. Calculate the percentage of energy lost after it hits the ground.

---

---

---

(2)

h. Mention **TWO** precautions needed to obtain accurate results.

- \_\_\_\_\_  
\_\_\_\_\_ (1)
- \_\_\_\_\_  
\_\_\_\_\_ (1)

i. Energy losses continually occur in everyday life. Describe **ONE** real life situation where a high percentage of energy loss is needed.

---

---

(1)

**(Total: 20 marks)**

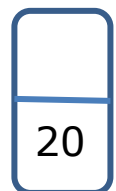

***Please turn the page.***

2a. Paul and Simon hang their cotton school T-shirt to dry after it has been washed. The diagram below shows how the two men hung their T-shirt.

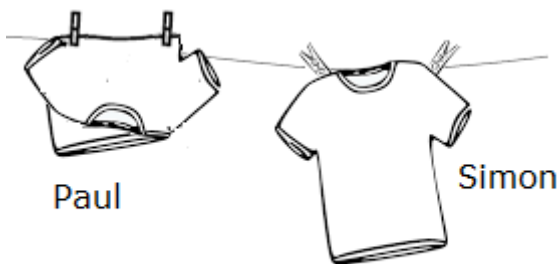

<http://getyourimage.club>

i. By which process is the heat transferred from the sun to clothes hung on the line.

\_\_\_\_\_ (1)

ii. Mention and explain the process by which the T-shirts will dry.

\_\_\_\_\_  
\_\_\_\_\_ (2)

iii. Which T-shirt will be the one to dry first? Give a reason for your answer.

\_\_\_\_\_  
\_\_\_\_\_ (2)

iv. How does the drying time change if a breeze starts blowing? Explain your answer.

\_\_\_\_\_  
\_\_\_\_\_ (2)

b. Paul and Simon iron their T-shirt as soon as it dries. They use two different ironing boards. Paul's ironing board is covered in a dark matt material, whereas Simon's is covered in a shiny silver material.

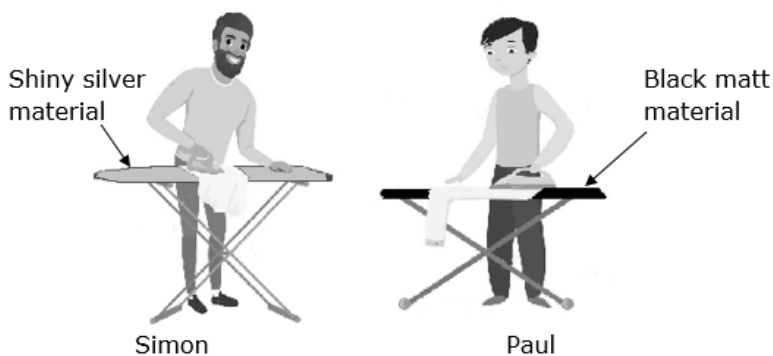

[www.dreamstime.com](http://www.dreamstime.com)

Which iron board is more efficient in transferring the heat onto the T-shirt so as to iron out all the creases? Explain your answer.

\_\_\_\_\_  
\_\_\_\_\_ (2)



c. Paul and Simon want to investigate the rate at which hot water cools down in two glass containers with two different surface cross-sectional areas. They were provided with containers A and B.

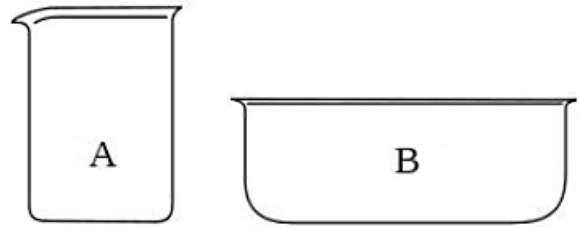

i. Mention **TWO** additional pieces of apparatus required to carry out this experiment.

- \_\_\_\_\_(1)
- \_\_\_\_\_(1)

ii. Briefly describe how they should carry out the experiment.

---



---



---

(4)

iii. Mention **TWO** factors that they should keep constant so that they would have a fair and reliable result.

---



---



---

(2)

iv. Simon and Paul plotted graphs X and Y of temperature in °C against time in minutes for both containers. Identify which graph belongs to container A and which graph belongs to container B. Explain how you arrived at your conclusion.

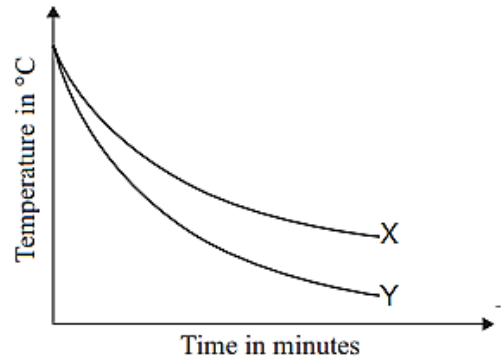

Graph X = \_\_\_\_\_

Graph Y = \_\_\_\_\_

Reason \_\_\_\_\_ (2)

d. The fennec fox lives in the hot Sahara Desert. It has very large ears through which it loses heat. Explain why this feature is important for an animal that lives in the desert.



---



---

(1)

**(Total: 20 marks)**

20

3. Michele is investigating properties of light as it passes through a rectangular glass.
- a. He shines a ray of light onto the rectangular glass block as shown in the figure below.
- i. Complete the diagram to show how the ray of light emerges out of the glass block. The normal lines should be included in the diagram. (3)

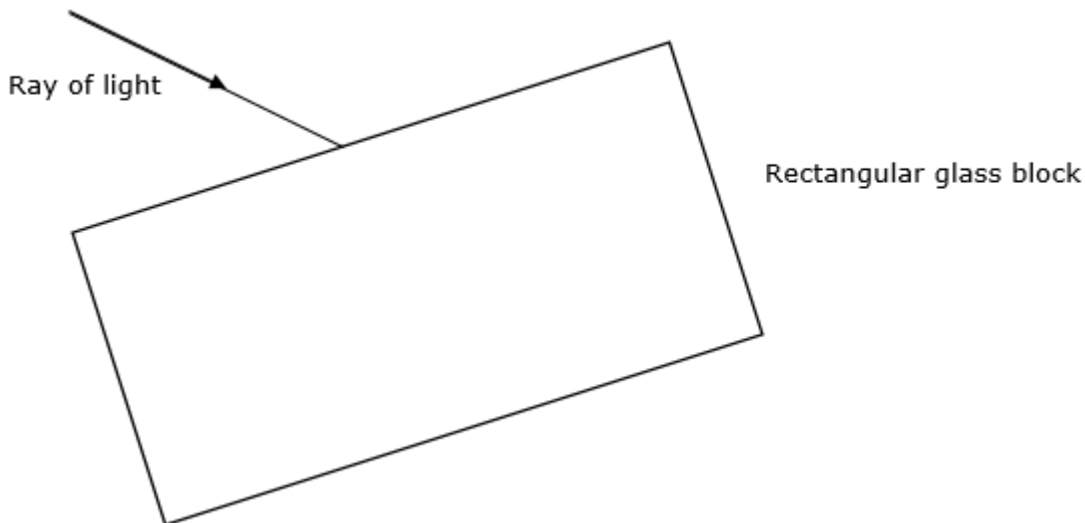

- ii. Mark the angle of incidence (using the letter **i**) and the angle of refraction (using the letter **r**). (2)
- iii. Michele finds out that the speed of light in air ( $3 \times 10^8$  m/s) decreases to  $2 \times 10^8$  m/s when it enters glass. Calculate the refractive index of glass.

\_\_\_\_\_

\_\_\_\_\_

\_\_\_\_\_ (2)

- iv. This experiment was repeated using water instead of the rectangular glass block. The outcome obtained will be different, explain what he will observe and why this happens.

\_\_\_\_\_

\_\_\_\_\_

\_\_\_\_\_ (2)

- v. At the point where it enters water, some of the light from the ray box seems to be getting reflected rather than refracted through water. Explain why this happens.

\_\_\_\_\_

\_\_\_\_\_

\_\_\_\_\_ (1)

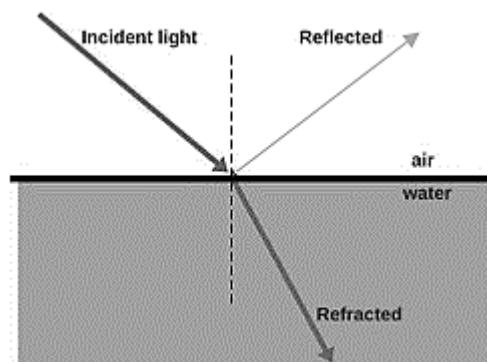

www.scienceabc.com

- b. He repeats the experiment using a glass prism and a beam of white light.  
 i. Complete the diagram below by drawing the path of light through the prism and its projection on the screen. (3)

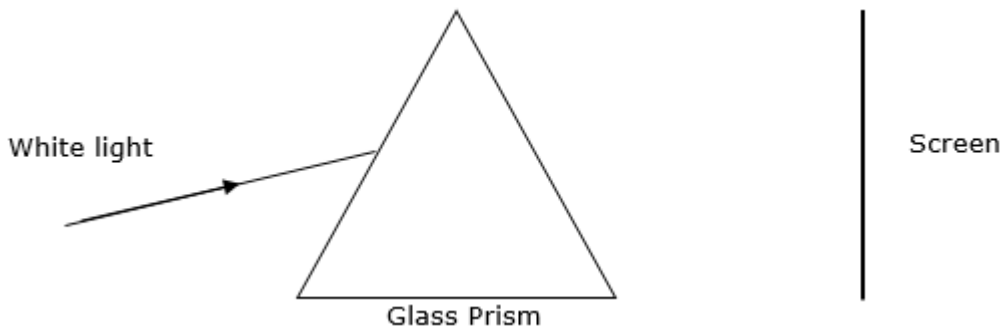

ii. What is the name of this phenomena? \_\_\_\_\_ (1)

iii. Explain why this happens.

(2)

iv. On the screen indicate the colour that will be observed at the top and the one that will be seen at the bottom of the screen. (2)

v. Rainbows are produced by using the same principle mentioned above. An example is seen in the diagram below. Name the phenomena taking place at A and B.

A: \_\_\_\_\_ (1)

B: \_\_\_\_\_ (1)

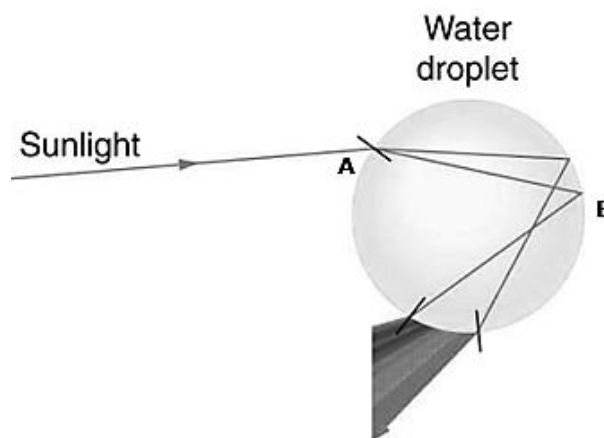

<https://courses.lumenlearning.com>

**(Total: 20 marks)**

20

4a. During a Physics lesson Timothy learns that when a polythene rod is rubbed with a cloth it becomes negatively charged while a perspex rod becomes positively charged when rubbed with the same cloth.

i. Explain, in terms of transfer of electrons, how these charges are produced in each rod.

\_\_\_\_\_ (2)

ii. Timothy finds it impossible to charge the rod using a damp rather than a dry cloth. Explain.

\_\_\_\_\_ (2)

b. Fill in the spaces to show the difference between the structure of conductors and insulators. The reason why charges flow easily in conductors but not in insulators is because some electrons in atoms of conductors are \_\_\_\_\_

while those in insulators are \_\_\_\_\_ (2)

c. Fill in the spaces below with the type of force experienced when a charged polythene rod is brought close to a similarly charged rod and then next to a charged perspex one. (2)

polythene next to polythene rod	
polythene next to perspex rod	

d. Timothy also learns that when liquid fuel flows through pipes, friction between the liquid fuel and the pipe can cause static electricity to build up. This can cause electrical discharges and sparks. What important property of the material used in such pipes would greatly reduce this fire risk?

\_\_\_\_\_ (1)

e. Lightning conductors protect buildings from potential damage due to lightning strikes in thunderstorms. Explain.

\_\_\_\_\_ (1)

- f. Timothy is asked to carry out an experiment to measure the resistance of a 12 V filament lamp when different values of potential difference are applied to it.
- i. Draw in the space below a circuit diagram including an ammeter, a voltmeter, a switch and all the apparatus needed to carry out this experiment. (3)

ii. State if the resistance that an ammeter and voltmeter should be high or low.

- Ammeter: \_\_\_\_\_ (1)
- Voltmeter: \_\_\_\_\_ (1)

iii. Mention **ONE** precaution he should take to avoid damaging the filament lamp.

\_\_\_\_\_ (1)

iv. After the experiment Timothy finds that the resistance of the filament lamp does not remain constant when different values of potential difference are applied to it. Explain why this is so, stating also whether the filament lamp obeys Ohm's Law or not.

\_\_\_\_\_  
\_\_\_\_\_ (2)

v. Name **TWO** devices which have not been mentioned in this question, one which obeys Ohm's Law and one which does not.

- obeys Ohm's Law: \_\_\_\_\_ (1)
- does not obey Ohm's Law \_\_\_\_\_ (1)

**(Total: 20 marks)**



5a. The transformer is a useful device which is commonly found in electrical and electronic appliances amongst others.

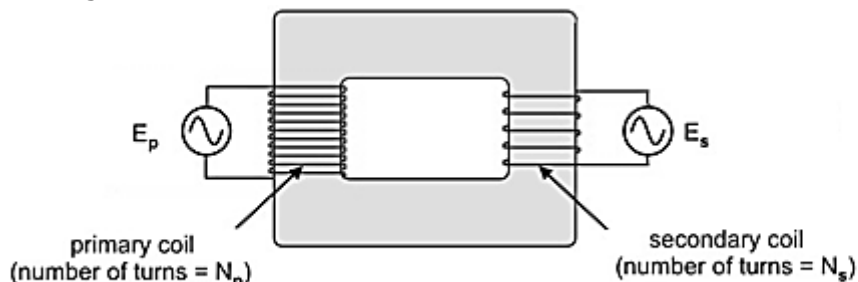

<https://saburchill.com/>

i. Explain clearly why an alternating voltage is produced across the secondary coil when an alternating voltage is applied across the primary coil.

---



---



---

(3)

ii. The alternating primary voltage is replaced with a direct voltage supply. The transformer did not work. Explain.

---

(1)

iii. Give **TWO** reasons why a transformer is not 100% efficient.

---



---

(2)

b. A cooking pot containing some water is placed on an electrical hob. The power rating of the heating element is 1.0 kW and is switched on for 12 minutes.

i. Calculate the energy, in J, supplied by the element in 12 minutes.

---



---

(2)

ii. Only 60% of the energy in part (i) is absorbed by the water. Calculate the amount of wasted energy.

---



---

(1)

iii. Name **TWO** objects which have absorbed some of this wasted energy.

---

(2)

iv. Calculate the energy consumed by the element, in kWh in these 12 minutes.

---



---

(2)

v. Calculate the cost of heating the water if 1 kWh of electrical energy costs 12c.

---



---

(1)

- c. A novel type of cooking hob has been introduced on the market in these last years. This is the induction hob, a simplified diagram of which is shown here. In such an induction hob, the object to be heated is placed on the top of the hob which is made of a ceramic surface. Underneath this surface there is a coil of copper wire and a high frequency alternating current is passed through it. The resulting oscillating magnetic field repeatedly induces a voltage in the pan. This produces large eddy currents in the pan which cause it to heat up rapidly.

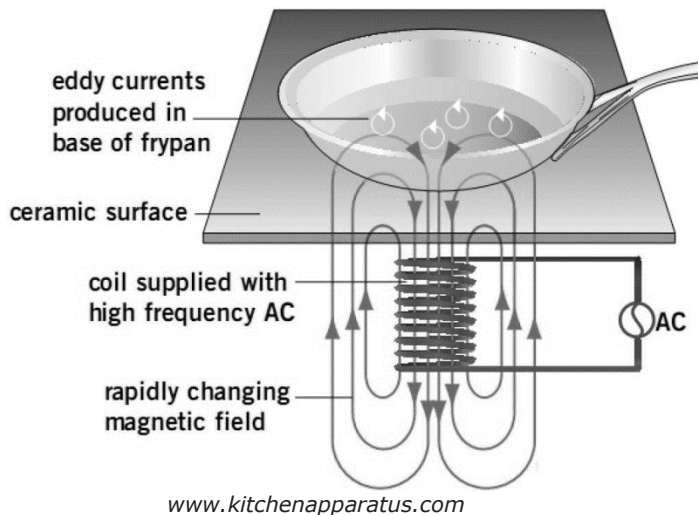

- i. Explain the meaning of high frequency alternating current.

\_\_\_\_\_ (2)

- ii. The top ceramic surface is made of an electrical insulating material. Explain why the surface of this cooker remains cooler to the touch than that of a conventional heating element type.

\_\_\_\_\_ (1)

- iii. Explain why the eddy currents here cause the pan to heat up a lot while the eddy currents in a transformer do not heat its core that much.

\_\_\_\_\_ (1)

- iv. The power rating of one such cooking top is 1.5 kW. Calculate the current it takes from a 230 V supply.

\_\_\_\_\_ (2)

**(Total: 20 marks)**

20

**Blank Page**





SUBJECT:	<b>Physics</b>
PAPER NUMBER:	IIB
DATE:	19 <sup>th</sup> September 2020
TIME:	4:00 p.m. to 6:05 p.m.

**Answer ALL questions.**

**You are requested to show your working and to write the units where necessary.  
When necessary, take  $g$ , acceleration due to gravity, as  $10\text{m/s}^2$ .**

<b>Density</b>	$m = \rho V$
<b>Pressure</b>	$F = p A$ $p = \rho g h$
<b>Moments</b>	Moment = $F \times$ perpendicular distance
<b>Energy and Work</b>	$PE = m g h$ $KE = \frac{1}{2} m v^2$ $W = F s$
	Work Done=energy converted $E = P t$
<b>Force and Motion</b>	$m a =$ unbalanced force $W = m g$ $v = u + a t$
	average speed = $\frac{\text{total distance}}{\text{total time}}$ $s = (u + v) \frac{t}{2}$
	$v^2 = u^2 + 2 a s$ $s = u t + \frac{1}{2} a t^2$ momentum = $m v$
<b>Waves</b>	$\eta = \frac{\text{speed of light in air}}{\text{speed of light in medium}}$ $v = f \lambda$
	$\eta = \frac{\text{real depth}}{\text{apparent depth}}$ Magnification = $\frac{\text{image distance}}{\text{object distance}}$
	Magnification = $\frac{\text{image height}}{\text{object height}}$ $T = \frac{1}{f}$
<b>Electricity</b>	$Q = I t$ $V = I R$ $E = Q V$
	$P = I V$ $R \propto \frac{L}{A}$ $E = I V t$
	$R_{\text{total}} = R_1 + R_2 + R_3$ $\frac{1}{R_{\text{total}}} = \frac{1}{R_1} + \frac{1}{R_2}$
<b>Electromagnetism</b>	$\frac{V_p}{V_s} = \frac{N_p}{N_s}$ $V_p I_p = V_s I_s$
<b>Heat</b>	$Q = m c \Delta\theta$
<b>Radioactivity</b>	$A = Z + N$
<b>Other equations</b>	Area of a triangle = $\frac{1}{2} b h$ Area of a trapezium = $\frac{1}{2} (a + b) h$
	Area of a circle = $\pi r^2$

1. Andrea and Melvin want to investigate the relationship between the energy lost on a bounce of different balls. They set up the apparatus as shown in the diagram and decided to use three different balls (tennis ball, ping pong and golf ball).

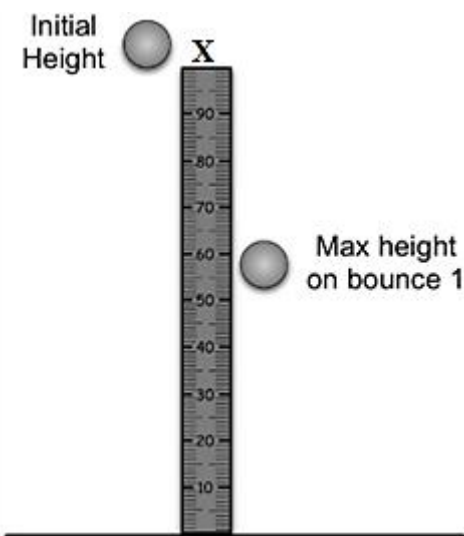

- a. List the energy changes taking place as the ball is released until it hits the ground. (3)

→  +

- b. Fill in the blanks to complete the following sentences.

Hold the \_\_\_\_\_ at point X and measure the \_\_\_\_\_ using a \_\_\_\_\_.  
 Release it and record the height of the ball reached after it \_\_\_\_\_ off the floor.  
 Repeat this procedure for the other two balls. (4)

- c. Determine the potential energy of the tennis ball if it is released from a height of 1 m and has a mass of 0.06 kg.

\_\_\_\_\_  
 \_\_\_\_\_  
 \_\_\_\_\_ (2)

- d. Calculate the final velocity of the ball just before it hits the ground.

\_\_\_\_\_  
 \_\_\_\_\_  
 \_\_\_\_\_ (2)

---

e. State the law used to work out the previous question.

---

---

(2)

f. After it hits the ground the tennis ball reaches a height of 0.56 m. Calculate the potential energy of the tennis ball after it hits the ground.

---

---

(2)

g. Calculate the percentage of energy lost after it hits the ground by using the equation  $\text{efficiency} = \frac{\text{output energy}}{\text{input energy}} \times 100$ .

---

---

(2)

h. Mention **ONE** precaution needed to obtain more accurate results.

---

(1)

i. Energy losses occur frequently in everyday life. Describe **ONE** real life situation where a high percentage of energy loss is needed. Explain your answer.

---

---

(2)

**(Total: 20 marks)**

20

2a. Paul and Simon hang their cotton school t-shirt to dry after it has been washed. The diagram below shows how the two men hung their t-shirt.



<http://getyourimage.club>

i. By which method does heat travel from the sun to the t-shirts?

\_\_\_\_\_ (1)

ii. The t-shirts dry because the water evaporates. Explain how the process of evaporation takes place.

\_\_\_\_\_  
\_\_\_\_\_ (2)

iii. Simon's t-shirt was the first one to dry. Give a possible reason why.

\_\_\_\_\_  
\_\_\_\_\_ (2)

iv. A fan is switched on in front of the t-shirts. Underline the correct word to complete the given sentence.

The drying time will be:

Longer                      Shorter                      The same                      (1)

b. Paul and Simon iron their T-shirt as soon as it dries. They use two different ironing boards. Paul's ironing board is covered in a dark matt material, whereas Simon's is covered in a shiny silver material.

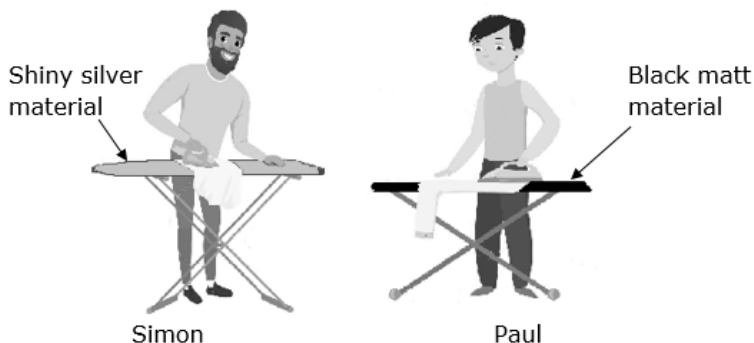

[www.dreamstime.com](http://www.dreamstime.com)

Which iron board is more efficient in transferring the heat onto the t-shirt to iron out all the creases? Explain your answer.

\_\_\_\_\_  
\_\_\_\_\_ (2)

c. Paul and Simon want to investigate the time taken for hot water to cool down in two glass containers of different surface cross-sectional areas. They were provided with the glass beakers A and B.

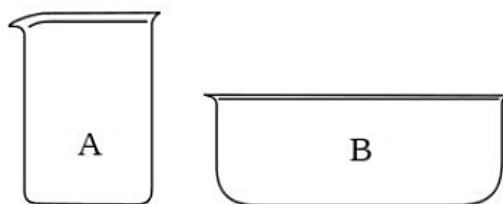

i. List **TWO** additional pieces of apparatus required to carry out this experiment.

- \_\_\_\_\_
- \_\_\_\_\_

(2)

ii. Use the numbers 1 to 5 to rearrange the following list in order to obtain the correct sequence of events that describe this experiment. (5)

	The stopwatch is switched on and the temperature of the water in both beakers is recorded every 2 minutes.
	The final temperature of the water in each beaker is recorded
	The temperature drop in each beaker is calculated by subtracting the final temperature from the initial temperature.
	Some boiling water was poured into each beaker.
	The initial temperature of the water in each beaker was recorded

iii. Mention **TWO** precautions that Simon and Paul need to take, to ensure a fair and reliable result.

\_\_\_\_\_ (2)

iv. Which Beaker do you think will cool down first? Underline the correct answer.

Beaker A

Beaker B

(1)

d. The fennec fox lives in the hot Sahara Desert. It has very large ears through which it loses heat. Explain why this feature is important for an animal that lives in the desert.



www.123rf.com

\_\_\_\_\_ (2)

**(Total: 20 marks)**



3. Michele is investigating properties of light as it passes through a rectangular glass block.
- a. He shines a ray of light onto the rectangular glass block as shown in the figure below.
- i. Complete the diagram to show how the ray of light emerges out of the glass block. The normal must be included. (3)

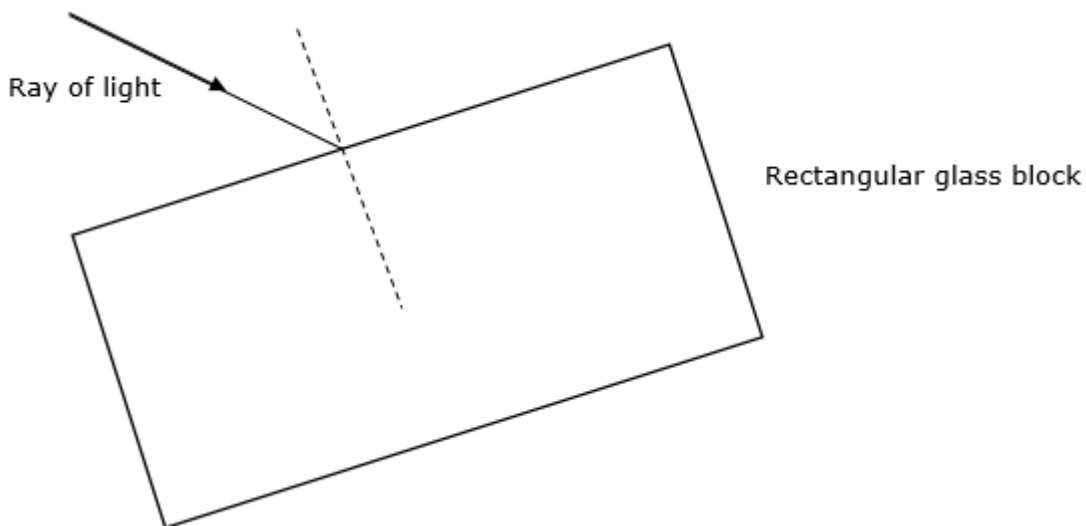

- ii. Mark the angle of incidence (using the letter **i**) and the angle of refraction (using the letter **r**). (2)

- iii. Michele finds out that the speed of light in air ( $3 \times 10^8$  m/s) decreases to  $2 \times 10^8$  m/s when it enters glass. Calculate the refractive index of glass.

\_\_\_\_\_

\_\_\_\_\_

\_\_\_\_\_ (2)

- iv. This experiment was repeated using water instead of the rectangular glass block. The outcome obtained will be different, explain what he will observe and why this happens.

\_\_\_\_\_

\_\_\_\_\_

\_\_\_\_\_ (2)

- b. At the point where light enters water, some light from the ray box seems to be getting reflected rather than refracted through water. Explain why this happens.

\_\_\_\_\_

\_\_\_\_\_

\_\_\_\_\_ (1)

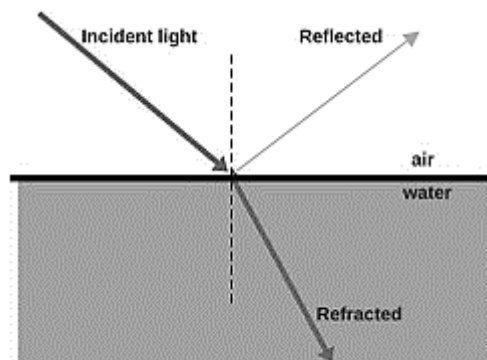

c. He repeats the experiment using a glass prism and a beam of white light.

i. Complete the diagram below by drawing the projection on the screen. (3)

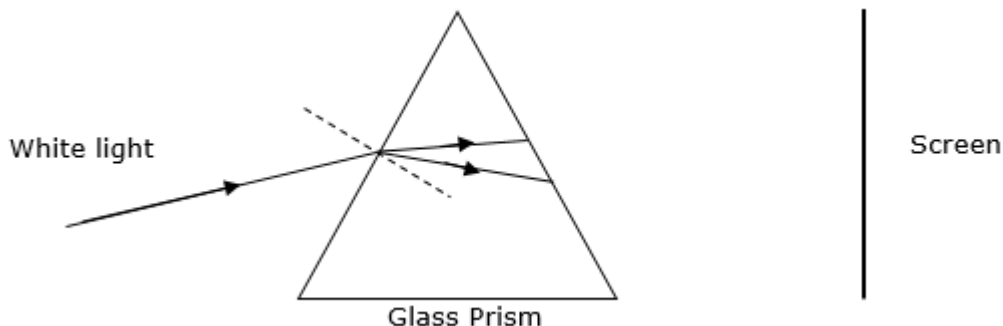

ii. What is the name of this phenomena? \_\_\_\_\_ (1)

iii. Explain why this happens.

\_\_\_\_\_  
 \_\_\_\_\_ (2)

iv. On the screen indicate the colour that will be observed at the top and the one that will be seen at the bottom of the screen. (2)

v. Rainbows are produced by using the same principle mentioned above. An example is seen in the diagram below. Name the phenomena taking place at A and B.

A: \_\_\_\_\_ (1)

B: \_\_\_\_\_ (1)

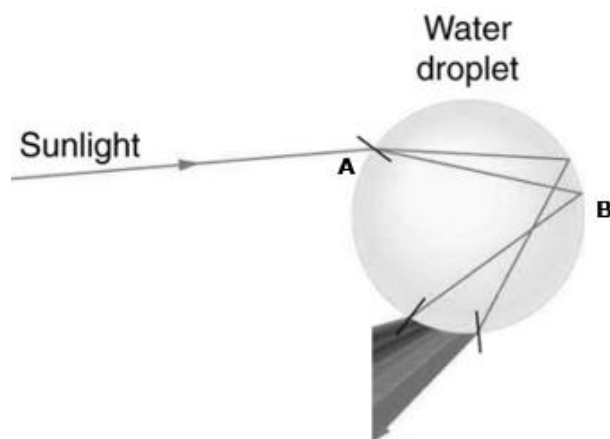

**(Total: 20 marks)**

20

4a. During a Physics lesson Timothy learns that when a polythene rod is rubbed with a cloth it becomes negatively charged while a perspex rod becomes positively charged when rubbed with the same cloth.

i. Fill in the blanks to complete the following sentence.

This happens because with polythene, electrons are transferred from \_\_\_\_\_ to \_\_\_\_\_, while with perspex the transfer is from \_\_\_\_\_ to \_\_\_\_\_.

(2)

ii. Timothy finds it impossible to charge the rod using a moist rather than a dry cloth. Explain.

(2)

b. Fill in the spaces to show the difference between the structure of conductors and insulators.

The reason why charges flow easily in conductors but not in insulators is because some electrons in atoms of conductors are \_\_\_\_\_ while those in insulators are \_\_\_\_\_.

(2)

c. Fill in the spaces below with the type of force experienced when: (2)

a charged polythene is brought next to a charged polythene rod	
a charged polythene is brought next to a charged perspex rod	

d. Timothy also learns that when liquid fuels flow through pipes, friction between the liquid fuel and the pipe walls can cause static electricity to build up. This can cause sparks. To prevent this, these pipes are made of a conducting material. Explain how this helps.

(1)

e. A lightning conductor helps to protect buildings from damage due to lightning strikes in thunderstorms. Such a conductor consists of a thick piece of copper running down vertically along the outer walls of the building. The top end of this conductor is placed high up on the roof of the building. Where is its bottom end connected to?

(1)



- f. Timothy is asked to carry out an experiment to measure the resistance of a 12 V filament lamp when different values of potential difference are applied to it.
- i. Draw in the space below a diagram of the circuit needed to carry out this experiment. Your diagram should include the following: filament lamp, battery, ammeter, voltmeter, switch and variable resistor. (3)

- ii. Fill in the blanks with the words 'high' or 'low', to complete the following sentence.
- An ammeter should have a \_\_\_\_\_ resistance while a voltmeter should have a \_\_\_\_\_ resistance. (2)

- iii. Mention **ONE** precaution he should take to avoid damaging the filament lamp. (1)

- iv. After the experiment Timothy finds that the resistance of the filament lamp does not remain constant when different values of voltage are applied to it. This is because it is not an ohmic conductor. State Ohm's law. (2)

- v. Name **TWO** devices which have not been mentioned in this question, one which obeys Ohm's Law and one which does not.

- obeys Ohm's Law: \_\_\_\_\_ (1)
- does not obey Ohm's Law \_\_\_\_\_ (1)

**(Total: 20 marks)**



5a. The transformer is a useful device which is commonly found in electrical and electronic appliances amongst others.

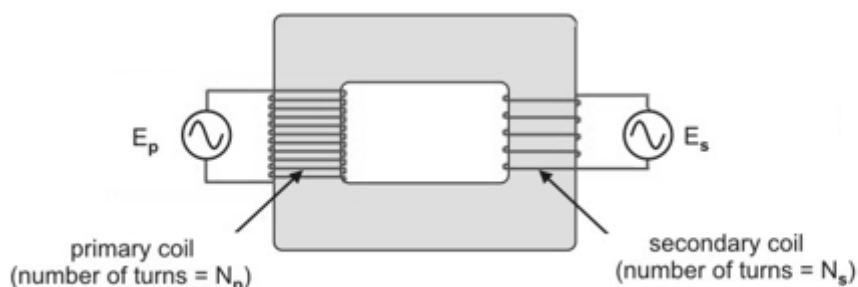

<https://saburchill.com/>

i. Rearrange the following statements in order using the numbers 1 to 4, to show how a transformer works. (4)

The secondary coil lies in the changing magnetic field	
An alternating voltage is applied across the primary coil	
A voltage is induced across the secondary coil	
A changing magnetic field is produced in the core	

ii. Give **TWO** reasons why a transformer is not 100% efficient.

- \_\_\_\_\_ (1)
- \_\_\_\_\_ (1)

b. A cooking pot containing some water is placed on an electrical hot plate. The power rating of the heating element is 1 kW (1000 W) and is switched on for 12 minutes (0.2 hour).

i. Calculate the energy, in J, supplied by the element in 12 minutes.

\_\_\_\_\_ (2)

ii. 40% of the energy in part (i) is wasted and is not absorbed by the water. Calculate the amount of wasted energy.

\_\_\_\_\_ (1)

iii. Name **TWO** objects which have absorbed some of this wasted energy.

\_\_\_\_\_ (2)

iv. Calculate the energy, in kWh, consumed in these 12 min by the element.

\_\_\_\_\_ (2)

v. Calculate the cost of heating the water if 1 kWh of electrical energy costs 12c.

\_\_\_\_\_ (1)

c. A novel type of cooking hob has been introduced on the market in these last years. This is the induction hob, a simplified diagram of which is shown here.

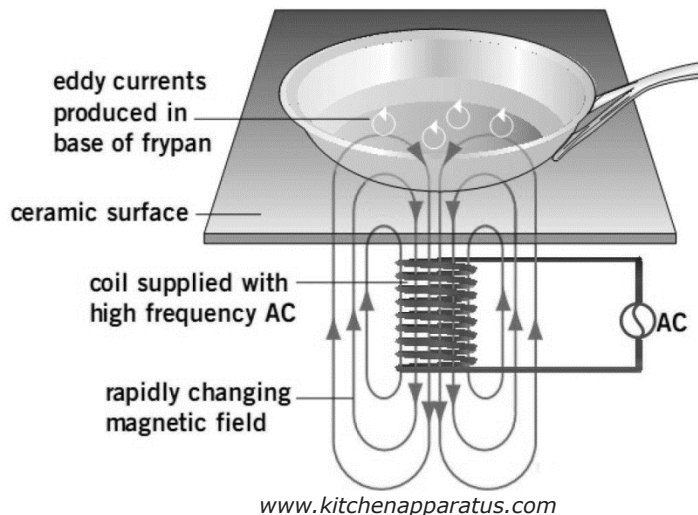

In such an induction hob, a pan is placed on the top of the hob which is made of a ceramic surface. Underneath this surface there is a coil of copper wire and a high frequency alternating current is passed through it. The oscillating magnetic field produces large eddy currents in the pan which cause it to heat up rapidly.

i. Explain the meaning of the following words:

- alternating current \_\_\_\_\_ (1)
- high frequency \_\_\_\_\_ (1)
- eddy currents \_\_\_\_\_ (1)

ii. The top ceramic surface is made of an electrical insulating material. Explain why the surface of this cooker remains cooler to the touch than that of a conventional electric heating element.

\_\_\_\_\_ (1)

iii. The power rating of one such cooking top is 1500 W. Calculate the current it takes from a 230 V supply.

\_\_\_\_\_  
 \_\_\_\_\_ (2)

**(Total: 20 marks)**

**Blank Page**