



SUBJECT:	Physics
PAPER NUMBER:	I
DATE:	26 th August 2022
TIME:	9:00 a.m. to 11:05 a.m.

Answer all questions.

**You are requested to show your working and to write the units where necessary.
When necessary, take g , acceleration due to gravity, as 10 m/s^2 .**

Density	$m = \rho V$
Pressure	$F = p A$ $p = \rho g h$
Moments	Moment = $F \times$ perpendicular distance
Energy and Work	$PE = m g h$ $KE = \frac{1}{2} m v^2$ $W = F s$
	Work Done = energy converted $E = p t$
Force and Motion	$m a =$ unbalanced force $W = m g$ $v = u + a t$
	average speed = $\frac{\text{total distance}}{\text{total time}}$ $s = (u + v) \frac{t}{2}$
	$v^2 = u^2 + 2 a s$ $s = u t + \frac{1}{2} a t^2$ momentum = $m v$
Waves	$\eta = \frac{\text{speed of light in air}}{\text{speed of light in medium}}$ $v = f \lambda$
	$\eta = \frac{\text{real depth}}{\text{apparent depth}}$ Magnification = $\frac{\text{image distance}}{\text{object distance}}$
	Magnification = $\frac{\text{image height}}{\text{object height}}$ $T = \frac{1}{f}$
Electricity	$Q = I t$ $V = I R$ $E = Q V$
	$P = I V$ $R \propto \frac{1}{A}$ $E = I V t$
	$R_{\text{total}} = R_1 + R_2 + R_3$ $\frac{1}{R_{\text{total}}} = \frac{1}{R_1} + \frac{1}{R_2}$
Electromagnetism	$\frac{V_p}{V_s} = \frac{N_p}{N_s}$ $V_p I_p = V_s I_s$
Heat	$Q = m c \Delta \theta$
Radioactivity	$A = Z + N$
Other equations	Area of a triangle = $\frac{1}{2} b h$ Area of a trapezium = $\frac{1}{2} (a + b) h$
	Area of a circle = πr^2

1. The following graph represents the orbital speed of the planets in our solar system plotted against their respective distance from the sun.

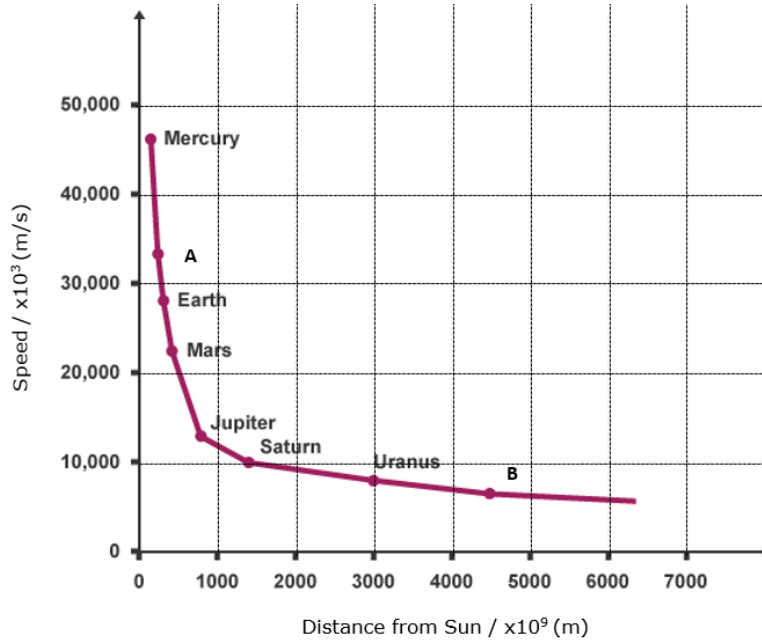

- a. Name the force that keeps all the planets orbiting around the sun. (1)

- b. Briefly explain the relationship between the mass of a planet and the force identified in part (a). (2)

- c. Name the planets that correspond to coordinates A and B. (2)
A: _____ B: _____
- d. Outline **TWO** differences between a star and a planet. (2)

- e. By using the graph, calculate the time taken for sunlight to reach planet B in our solar system if the speed of light is 3×10^8 m/s. (2)

- f. Pluto is now considered a 'dwarf planet'. On the same graph, mark with a 'P' where Pluto would be represented. (1)

(Total: 10 marks)

2. During a field trip, a student found two metal objects, which were held close to each other by an unknown attraction force. These two objects were taken to the school lab for further investigation.

a. Name the force of attraction between the two objects.

(1)

b. A magnet with known poles is brought close to the objects. Explain how the student can identify whether any one of the objects is a magnet.

(2)

c. The student concluded that only one of the objects is a magnet. However, the other object still experiences a force of attraction. Explain.

(2)

d. The objects were left near a very hot object and after some time, it was noted that the force of attraction between the two objects decreased significantly. Explain.

(2)

e. Explain **ONE** simple procedure how the magnet object can re-gain its original properties.

(1)

f. Laboratory steel magnets tend to keep their properties for a longer period of time than iron magnets. Explain why.

(2)

(Total: 10 marks)

3. The diagram shows a circuit having a 12 V battery, switch, copper wire and rheostat connected in series. Two bar magnets are placed around the copper wire, one on each side opposite to each other.

a. On the diagram, indicate with an arrow the direction of the current when the switch is closed. (1)

b. In which direction will the wire experience a force when the switch is closed? (1)

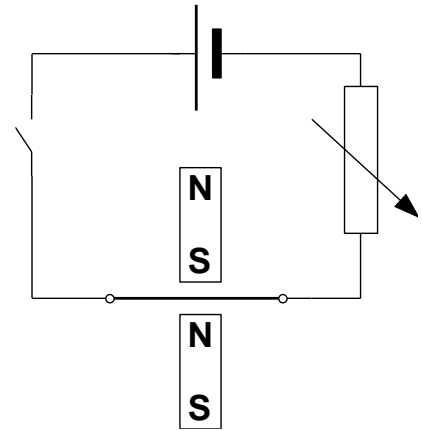

c. Name the rule used to identify the direction of the force on the wire. (1)

d. Identify **ONE** precaution during this experiment. (1)

e. In **each** scenario, outline how the force acting on the wire is affected:
 i. Stronger magnets are used.

Outcome: _____ (1)

Reason: _____ (1)

ii. Copper wire is replaced with tungsten (copper being better electrical conductor than tungsten).

Outcome: _____ (1)

Reason: _____ (1)

iii. The polarity of the battery is reversed.

Outcome: _____ (1)

Reason: _____ (1)

(Total: 10 marks)

4. Some quantities are scalars, others are vectors.
 a. Complete the table. The first one has been done. (3)

Quantity	Scalar	Vector
Momentum		✓
Speed		
Distance		
Velocity		

- b. A car of mass 1500 kg travels at a velocity of 20 m/s. Calculate its momentum.

 _____ (2)

- c. In a crash test, a car runs into a wall and stops.



(Source: <https://abcnews.go.com/Business/small-cars-tested-safety>)

- i. If the momentum of the car before the crash is 22500 kgm/s and the time of collision until the car comes to rest is 0.14 s, calculate the average force on the car during the crash.

 _____ (2)

- ii. With reference to Newton's Laws, explain how seatbelts can reduce injuries to passengers during a crash.

 _____ (2)

- iii. Racing drivers often complain that during braking, the seatbelt injures the drivers by applying a large pressure on their chest. Suggest **ONE** improvement of the seatbelt to overcome this problem.

_____ (1)

(Total: 10 marks)

5. During an outing with their teacher, students collected several small pieces of rock. These pieces were all of the same material but of different sizes. Back at school they measured their mass and their volume and put the results in a table shown below.

volume / cm ³	6	14	20	27	35
mass / g	16	35	57	73	98

a. Name the instruments needed to measure the mass and volume of the rocks.

mass: _____ (1)

volume: _____ (1)

b. Plot a graph of volume on the x-axis against mass on the y-axis. (4)

c. Use the graph to calculate the density of the rock, giving also its unit.

_____ (2)

d. Explain whether the pieces of rock will sink or float if they are placed in water.

_____ (1)

e. On your graph, draw another line showing what the graph would look like if the rock pieces were made of a denser material. Label this graph with the letter D. (1)

(Total: 10 marks)

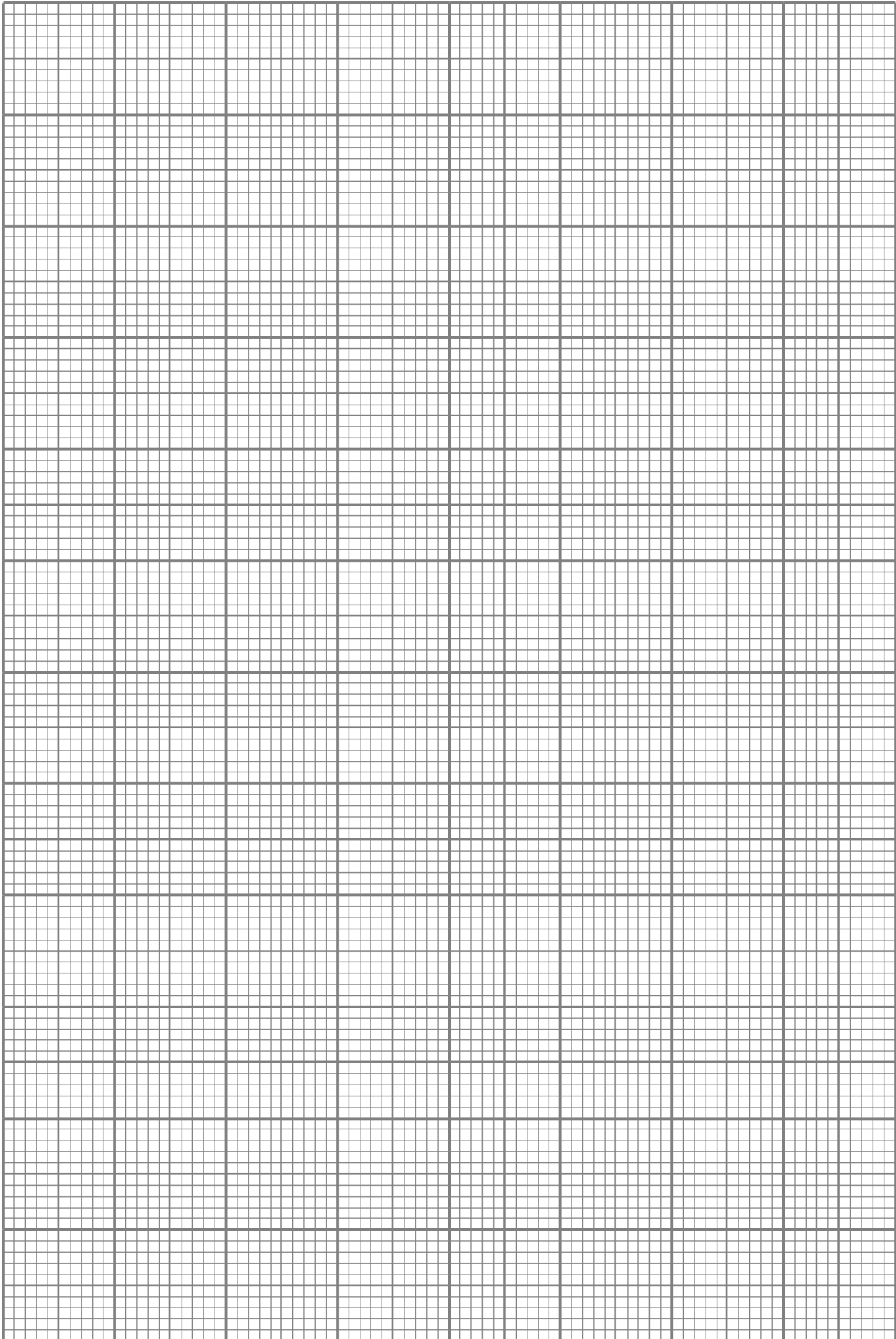

6. The figure below shows a metal lightning rod affixed to a tall building. The rod serves as a lightning conductor.

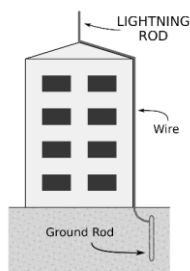

(Source: <http://www.icrt.com.tw/>)

- a. Suggest a suitable material to be used as the lightning rod.

_____ (1)

- b. The lightning rod is connected to earth. Explain why certain appliances do **not** have an earth wire.

 _____ (1)

- c. A lightning bolt strikes the top of a lightning rod and produces a current in the rod of 15000 A for 0.002 s.

- i. Calculate the charge that flows between the cloud and the building during that time.

 _____ (2)

- ii. If a lightning flash has a voltage of 3×10^8 V. Calculate the electrical energy discharged by lightning.

 _____ (2)

- d. Choose whether the following statements are True or False and give an explanation.

- i. The resistance of a rod twice the length of the rod shown in the figure increases.

True or False _____ (1)

Explanation: _____
 _____ (1)

- ii. The resistance of a rod which is thicker than the rod shown in the figure is the same.

True or False _____ (1)

Explanation: _____
 _____ (1)

(Total: 10 marks)

7. The definition of a force in a Physics textbook is found to be a pull or a push which one object exerts on another.
- a. In the following table, mark with an X to show whether the following forces are examples of a push, a pull or both. (2)

FORCES	PUSH	PULL	PUSH or PULL
force of gravity			
reaction force of the road on a car			
Opening a door			
force between magnets			

- b. Fill in the following:
- Forces can have many effects on an object; for example they may cause an object to turn. This turning effect is known as a _____ (1)
- c. A uniform rod AB of weight 10 N and 0.3 m long is pivoted at one end A.
- i. On the diagram below, draw the forces acting on the rod. (2)



- ii. Calculate the force E which must be applied at end B to keep the rod horizontal. (3)

- iii. Fill in with the correct term.
- For an object, the weight normally seems to act on a point on the object known as: _____ (1)

- iv. Rod AB is replaced by a second rod CD shown below. How would this effect the position on the rod at which its weight acts? (1)



(Total: 10 marks)

8. This question is about heat.

a. The figure shows part of the setup needed to determine the value of specific heat capacity of solid aluminium block using a heater of known power. Label the **THREE** items A, B and C.

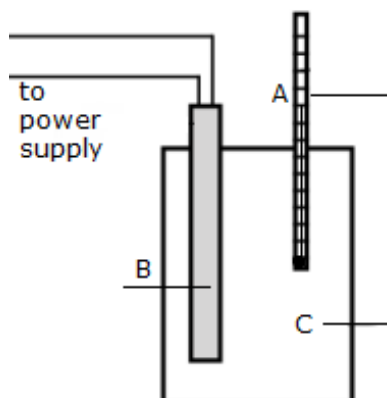

- A: _____ (1)
- B: _____ (1)
- C: _____ (1)

b. What needs to be placed around the block to ensure that most of the energy supplied by the heater is **not** lost to the surroundings?

_____ (1)

c. In this experiment the heater used had a power of 50 W and was switched on for 4 minutes.
i. Calculate the energy supplied by the heater in this time.

_____ (2)

ii. The mass of the block used was 1.2 kg and the rise in temperature of the block was found to be 10.5 °C. Calculate the value of specific heat capacity of aluminium obtained.

_____ (2)

d. Would you expect the actual value of specific heat capacity to be more or less than the value obtained above? Explain.

_____ (2)

(Total: 10 marks)

9. The figure shows a car travelling at 30 m/s on a level road. At this speed the car has to overcome a total constant force opposing motion of 600 N.

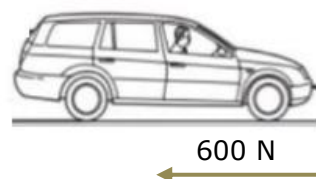

a. Find the distance travelled by the car in 10 s.

_____ (2)

b. Calculate the work done by the car engine during this time.

_____ (2)

c. Determine the power of the car engine during this time.

_____ (2)

d. Burning petrol, supplies 60 kJ of energy to the engine every second. Explain why your answer in part (c) is smaller than this value.

_____ (1)

e. Explain why the car uses more fuel travelling uphill at the same speed.

_____ (1)

f. Sketch a velocity time graph to show that the speed of the car was 30 m/s for 10 s, and after there was a deceleration to rest in 20 s. (2)

(Total: 10 marks)

10. The electromagnetic spectrum consists of seven different types of radiations, with different wavelengths.

- a. State the name of the radiation with the:
 - i. shortest wavelength; _____ (1)
 - ii. highest frequency. _____ (1)
- b. Tick **ONE** correct property of electromagnetic radiation. (1)

All radiations have the same frequency.	<input type="checkbox"/>
All radiations have the same frequency and speed in a vacuum.	<input type="checkbox"/>
All radiations have the same speed in a vacuum.	<input type="checkbox"/>

- c. i. Circle which of the following graphs below, A, B or C, describes correctly the relationship between the wavelength and frequency of electromagnetic waves. (1)

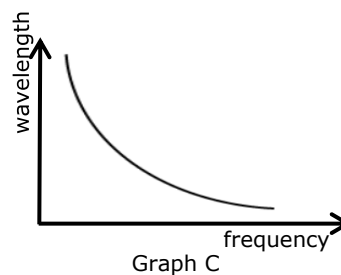
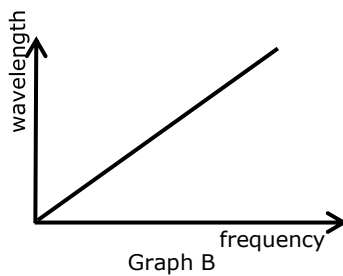
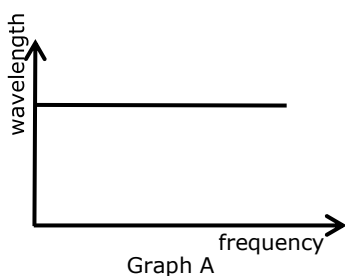

- ii. Explain your choice in part (i). (1)

- d. Radio waves and microwaves are both used for out of spaceship communication.
 - i. Distinguish between these two forms of waves in terms of their wavelength and frequency. (2)

_____ (2)

- ii. The first time astronauts landed on the Moon, they communicated with Earth using radio waves. The signal, travelling at 3×10^8 m/s took 1.25 s to reach Earth. Calculate the distance between the Moon and Earth. (2)

_____ (2)

- iii. Why **cannot** astronauts in space communicate with sound waves? (1)

_____ (1)

(Total: 10 marks)



SUBJECT:	Physics
PAPER NUMBER:	IIB
DATE:	26 th August 2022
TIME:	4:00 p.m. to 6:05 p.m.

Answer all questions.

You are requested to show your working and to write the units where necessary.

When necessary, take g , acceleration due to gravity, as 10m/s^2 .

Density	$m = \rho V$
Pressure	$F = p A$ $p = \rho g h$
Moments	Moment = $F \times$ perpendicular distance
Energy and Work	$PE = m g h$ $KE = \frac{1}{2} m v^2$ $W = F s$
	Work Done=energy converted $E = p t$
Force and Motion	$m a =$ unbalanced force $W = m g$ $v = u + a t$
	average speed = $\frac{\text{total distance}}{\text{total time}}$ $s = (u + v) \frac{t}{2}$
	$v^2 = u^2 + 2 a s$ $s = u t + \frac{1}{2} a t^2$ momentum = $m v$
Waves	$\eta = \frac{\text{speed of light in air}}{\text{speed of light in medium}}$ $v = f \lambda$
	$\eta = \frac{\text{real depth}}{\text{apparent depth}}$ Magnification = $\frac{\text{image distance}}{\text{object distance}}$
	Magnification = $\frac{\text{image height}}{\text{object height}}$ $T = \frac{1}{f}$
Electricity	$Q = I t$ $V = I R$ $E = Q V$
	$P = I V$ $R \propto \frac{1}{A}$ $E = I V t$
	$R_{\text{total}} = R_1 + R_2 + R_3$ $\frac{1}{R_{\text{total}}} = \frac{1}{R_1} + \frac{1}{R_2}$
Electromagnetism	$\frac{V_p}{V_s} = \frac{N_p}{N_s}$ $V_p I_p = V_s I_s$
Heat	$Q = m c \Delta\theta$
Radioactivity	$A = Z + N$
Other equations	Area of a triangle = $\frac{1}{2} b h$ Area of a trapezium = $\frac{1}{2} (a + b) h$
	Area of a circle = πr^2

1. This question is about pressure.

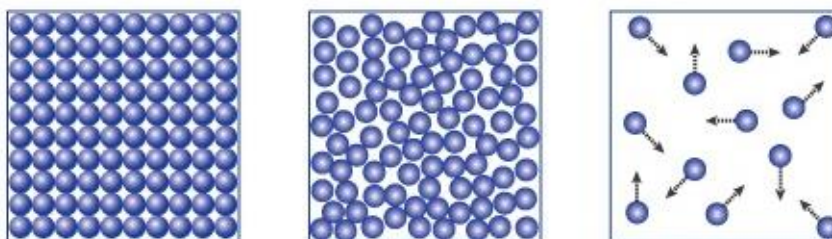

a. The diagram shows the arrangement of particles in each of the three states of matter: gases, liquids and solids. Under **each** diagram, write down the state it refers to. (3)

b. Using the diagrams above, explain the following:

i. liquids are denser than gases;

_____ (1)

ii. gases exert a pressure on the walls of their container.

_____ (1)

c. Circle the correct word/s in the following statements:

i. The difference in motion of particles in solids and gases is that in solids they (vibrate / move randomly) while in gases the particles (vibrate / move randomly). (2)

ii. If the air inside a closed syringe is compressed, the pressure of the air inside (decreases / increases / stays the same). (1)

iii. If a closed glass container containing air at 20 °C is placed in a refrigerator, after some time the pressure of the air inside the container (stays the same / decreases / increases). (1)

iv. The value of atmospheric pressure on top of a mountain is (greater than / the same as / less than) that at sea level. (1)

d. A group of students set up a model of a hydraulic machine in the laboratory, to be able to lift a heavy load as shown in the figure. Piston A has an area of 0.0005 m^2 and piston B has an area of 0.004 m^2 . Water is used as the hydraulic liquid in the system. To lift a heavy load placed on piston B, they applied an effort of 10 N on piston A as shown.

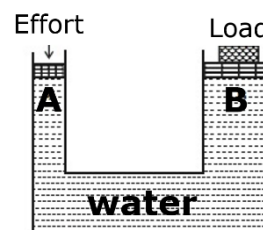

i. Calculate the pressure exerted on the liquid by piston A.

_____ (2)

ii. Hence or otherwise find the pressure exerted by the liquid on piston B.

_____ (1)

iii. Determine the force exerted on the load at B.

_____ (2)

iv. In practice the force exerted may be less than that calculated in part (iii). Name the force which is responsible for this loss in efficiency.

_____ (1)

v. Underline the correct word:

If piston A moves down 1 cm, then piston B moves up more / less than 1 cm. (1)

vi. In practice another liquid is actually used in hydraulic machines. Name this other liquid and state **ONE** advantage this other liquid has over water.

_____ (2)

vii. Apart from its use to lift heavy objects as in a hydraulic jack, name **ONE** other practical use of a hydraulic machine.

_____ (1)

(Total: 20 marks)

2. The following diagram shows an experimental setup. The solenoid, which is connected to the circuit, is placed on a sensitive electronic digital balance. A steel bar magnet is fixed with the clamp vertically above the solenoid. A meter ruler is fixed on the side of the stand and clamp.

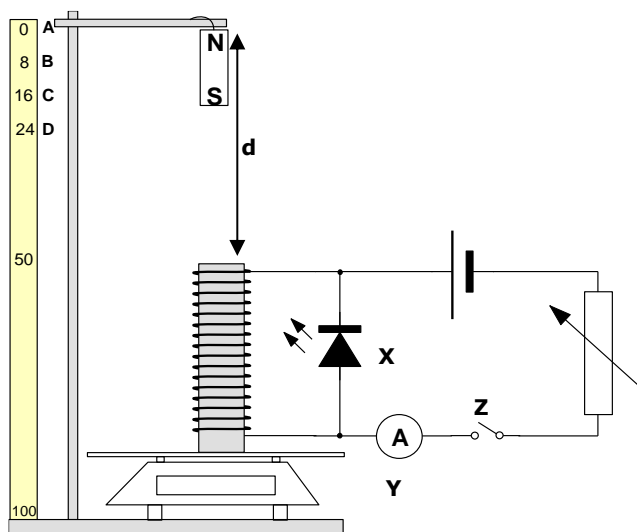

During the first part of the experiment, the relationship between the current flowing in the circuit and the magnetic force is being investigated. The number of wire turns on the solenoid and the distance between the bar magnet and the solenoid were kept constant throughout this part of the experiment.

- a. Name the **THREE** circuit components named X, Y and Z.

_____ (3)

- b. Fill in the spaces below with the most appropriate terms.

When the circuit switch is closed, the value on the electronic digital balance increases slightly. This is because when the current passes through the solenoid, a field is formed around it, similar to that of a bar magnet, having a _____ pole on the top part and the _____ pole on the lower part of the solenoid. The two south poles _____ each other and thus the digital balance records a higher value. (3)

- c. The mass of the solenoid is 160 g. Hence complete the following table below for increasing values of current.

Mass (g)	Mass (kg)	Magnetic Force (N)	Current (A)	Distance d (cm)
160	0.160	0	0	50
166	0.166	0.06	0.7	50
172	0.172		0.9	50
178	0.178		1.1	50

(2)

d. i. Fill in the blanks:

When the variable resistor is set on low resistance, the value on the electronic digital balance increases significantly. This is because when the variable resistor decreases its resistance, the overall current flowing in the circuit increased since current and resistance are _____ proportional to each other. The increase in current in the solenoid leads to a _____ field around the solenoid. Thus, the magnetic force is larger causing the electronic digital balance to read a _____ value. (3)

ii. When the cell polarity is reversed, the value on the electronic digital balance reads 160 g, and light is emitted from component X. Give a possible explanation for this.

_____ (2)

e. During the preparation of this setup, the bar magnet fell directly inside the solenoid while the circuit switch was still open. Light was temporarily emitted from component X. Explain with reference to the relevant law.

_____ (2)

During the second part of the experiment, the relationship between the distance, d and the magnetic force is being investigated. The number of wire turns on the solenoid and the variable resistor are kept constant throughout this part of the experiment.

f. Complete the following table below:

Mass (g)	Mass (kg)	Force (N)	Current (A)	Distance d (cm)
160	0.160	0	0	50
175	0.175	0.15	0.8	42
190			0.8	34
205			0.8	26

(2)

g. On the axes provided, sketch a graph of Force (N) against Distance (cm). (1)

h. What is the relationship between force and distance (bar magnet to solenoid)? Explain.

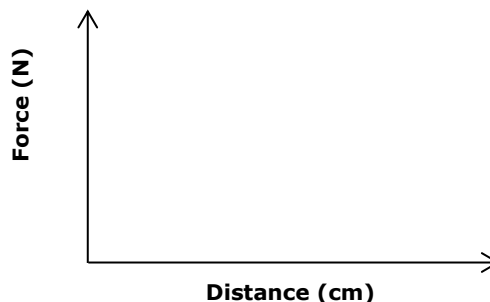

_____ (2)

(Total: 20 marks)

3. Kate wants to investigate what affects the height to which a tennis ball bounces.



a. Write numbers in the boxes to show the correct order of the experimental method. The first one has been done for you. (4)

Place a metre ruler vertically against a wall.	1
Record the rebound height of the first bounce.	
Repeat the experiment by dropping the ball from the 50 cm mark for 5 trials.	
Drop the ball from the 50 cm mark.	
Increase the dropping height by 50 cm each time and repeat the experiment.	

b. Mention **TWO** factors which must remain constant to ensure fair testing.

_____ (2)

c. Give **ONE** precaution, other than repeated readings, which must be taken to ensure accurate results.

_____ (1)

d. Construct a hypothesis for this investigation.

_____ (2)

e. In the space provided draw a table with headings and respective SI units, showing how Kate could represent her results. (3)

- f. In an attempt to measure the acceleration of free fall, Kate drops the ball from a height of 25 m. The ball falls from rest and takes 2.3 s to reach the ground.

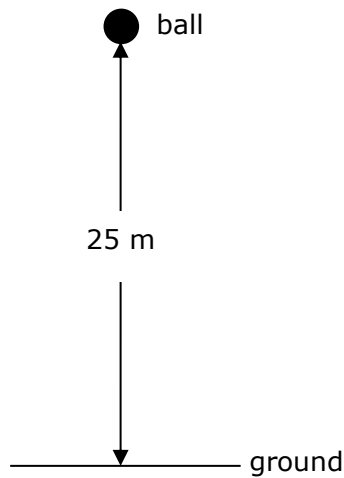

- i. Name the instrument used to measure the time taken by the ball to reach the ground.

_____ (1)

- ii. Calculate the average speed of the ball.

_____ (2)

- iii. Calculate the final speed of the ball as it hits the ground.

_____ (2)

- iv. Using Kate's results, determine the acceleration of free fall.

_____ (2)

- v. The accepted value for acceleration of free fall is 9.8 m/s^2 . Give **ONE** reason why the value calculated in part (iv) is less than this.

_____ (1)

(Total: 20 marks)

Please turn the page.

4. This question is about light.
- a. The figure shows a parallel beam of light incident on a lens.

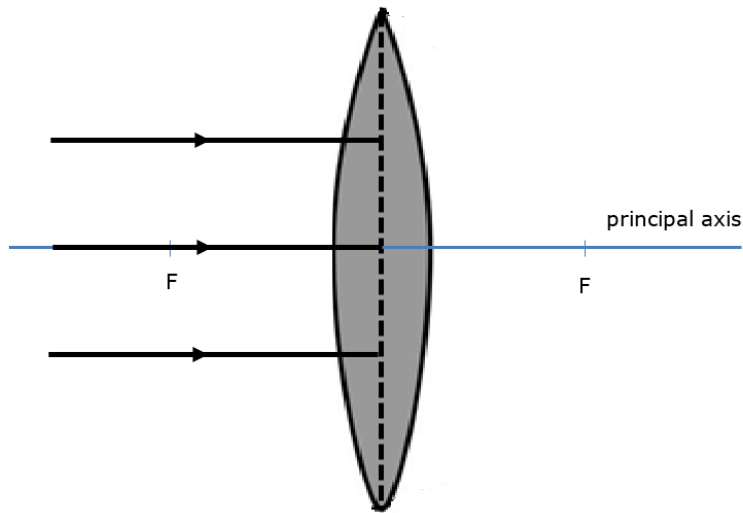

i. State the name of this type of lens.

(1)

ii. Complete the diagram to show how the light rays travel once passing through the lens.

(2)

iii. State the name of the distance between the centre of the lens and point F.

(1)

- b. The lens shown in part (a) can be used in cameras. An object, 2 cm high, labelled O, is placed at a distance beyond 2F away from the lens, represented by an arrow.

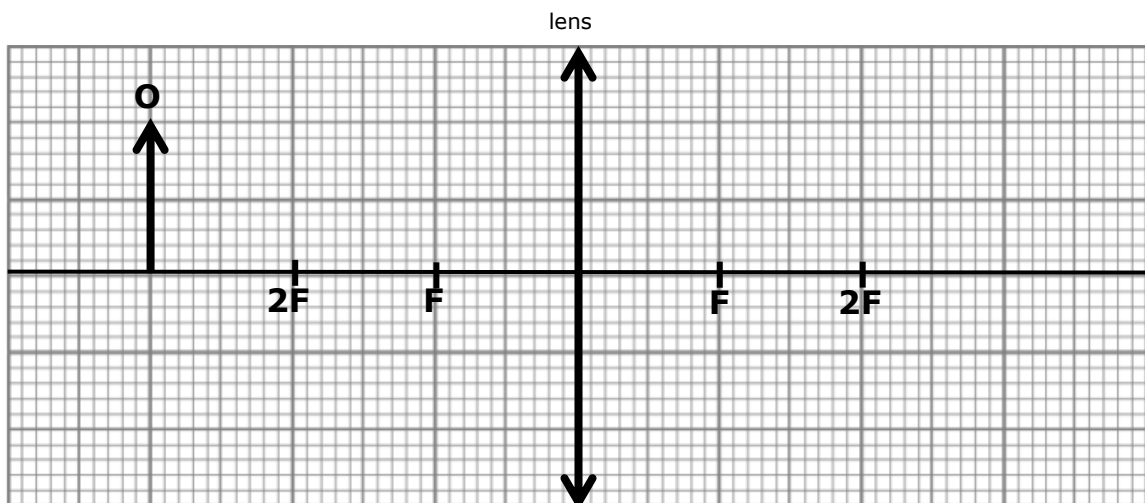

i. Draw **TWO** rays emerging from object O to complete the ray diagram and show how an image is formed. Label the image as I.

(4)

ii. List **THREE** properties of the image formed.

(3)

iii. Use a ruler to measure the height of the image. Hence calculate the magnification of the lens.

(3)

c. Water waves spread out as they pass through a small gap.

i. What is this phenomenon called? _____ (1)

ii. The diagram below shows a breakwater built close to a shore. Water waves, represented by wavefronts, approach the gap, and pass through it.

Mark **ONE** wavelength on the diagram with the symbol λ . (1)

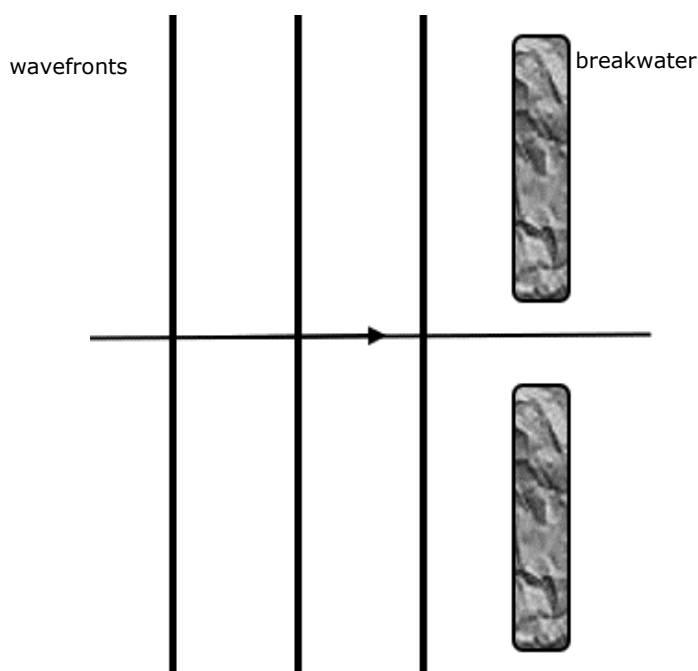

iii. Continue the diagram to show how waves spread beyond the gap in the breakwater. Your sketch should also indicate changes in the wavelength, if any. (2)

iv. Will the velocity of the waves be affected as they pass through the gap? Explain.

(2)

(Total: 20 marks)

5. This question is about Ohm's Law.

a. State Ohm's Law.

(2)

b. Complete the graph below to show the voltage-current characteristics of a filament lamp.

(1)



c. Does the filament lamp obey Ohm's law? Explain your answer using the shape of the graph sketched in part (b).

(2)

d. Three identical lamps rated at 2.5 V each are connected in series with a 6 V battery, a switch, and an ammeter.

i. Sketch a circuit diagram of the arrangement in the space provided below.

(4)

ii. Calculate the voltage across each lamp.

(1)

iii. Will the lamps light at full brightness? Explain.

_____ (2)

iv. Each lamp has a current of 0.3 A flowing through it. Calculate the resistance of each lamp.

_____ (2)

e. A 60 W filament lamp is left switched on for a whole week. Calculate the units of electricity consumed during this time.

 _____ (3)

f. The figure below shows the main components of a three-pin plug.

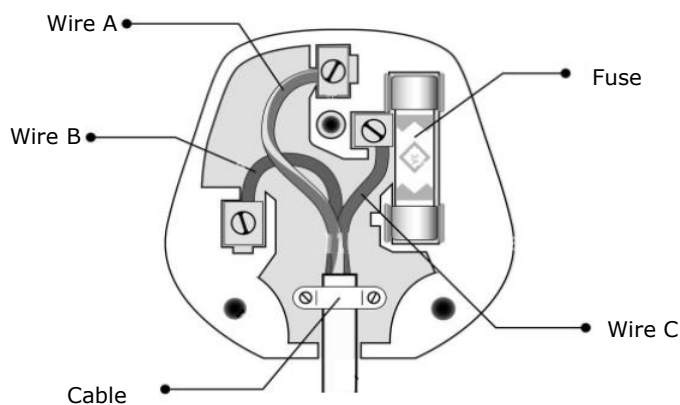

i. Identify the wire used for earthing. _____ (1)

ii. The fuse used in this plug is rated 3 A. Perform the necessary calculations to conclude if this plug can be used with a toaster rated at 850 W and connected to a 240 V mains supply.

 _____ (2)

(Total: 20 marks)

Blank Page