

MATRICULATION AND SECONDARY EDUCATION CERTIFICATE EXAMINATIONS BOARD
UNIVERSITY OF MALTA, MSIDA**SECONDARY EDUCATION CERTIFICATE LEVEL****MAY 2012 SESSION**

SUBJECT:	Textiles and Design
PAPER NUMBER:	I
DATE:	4 th May 2012
TIME:	9:00 a.m. to 11:00 a.m.

Answer ALL questions.

1. Below are two variations of a woman's loose-fitting jacket.



VIEW A Back



VIEW B Back



- View A has round patch pockets.
- View B has contrast fabric on left front and back, and optional appliques.

a) Identify **THREE** fashion features which are common to both styles.

- i) _____
- ii) _____
- iii) _____

(3 marks)

b) Polarfleece® is one of the suggested fabrics for this jacket.

i) Why is this fabric suitable for the jacket styles shown on page 1?

(1 mark)

ii) It is recommended to use knitted fabric for this jacket. Name and draw **ONE** type of machine stitching that is often used on this type of fabric.

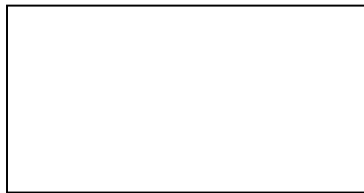

Name of machine stitch: _____ (1, 1 mark)

iii) Which type of machine needle and sewing thread are best used for knitted fabrics?

Machine needle: _____ (1 mark)

Sewing thread: _____ (1 mark)

iv) The jacket is to be unlined. Keeping this in mind, draw a suitable seam with a seam finish for this jacket. Name the type of seam finish used.



Name of seam finish: _____

(1, 1 mark)

- c) A tape is sewn on the shoulder seam of both jacket styles. Why is this done?

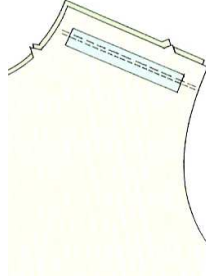

(1½ marks)

- d) The diagram below shows the preparation of the knitted fabric for the pattern layout.

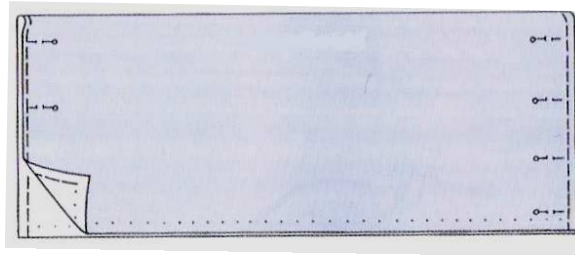

- i) Why is the knitted fabric pinned at the sides?

(1½ marks)



- ii) Two common terms used in commercial patterns are **FOLD** of fabric and **SELVEDGE**. Label and show with an arrow these **TWO** terms on the diagram in (d) above.

→ FOLD,

→ SELVEDGE.

(2 marks)

- e) The following pattern markings are shown on the pattern pieces of the jacket. Give the meaning of each one.

Pattern marking symbol	Meaning
	
	
	

(3 marks)

- f) List **THREE** measurements that are needed when selecting the size of the pattern for the jacket.

i) _____ ii) _____ iii) _____

(3 marks)

- g) The edges of style A and style B are finished with a crossway strip made from matching or contrasting fabric.

i) A crossway strip is cut on the _____.

(1 mark)

- ii) When more than one strip is required, joining is done on the straight grain. With the help of the diagrams below, explain how to join two pieces of crossway strip together.

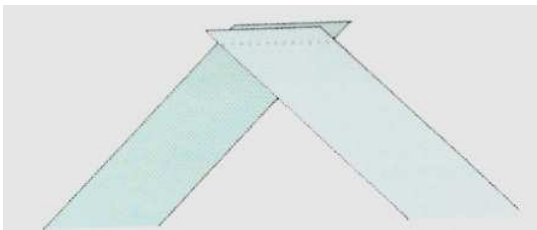
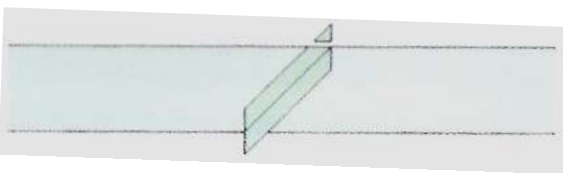
	
<hr/> <hr/> <hr/> <hr/>	<hr/> <hr/> <hr/> <hr/>

(4 marks)

- iii) Several faults may occur while joining two pieces of crossway strips together. The picture below shows a fault where the join makes an uneven level in the completed strip.

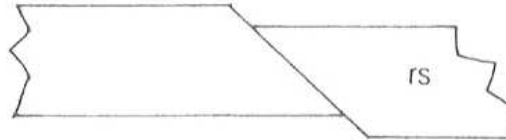

What is the cause of this fault?

(2 marks)

- iv) To secure the crossway strip on the wrong side, hand stitching may be used. Name the stitch which is often used for this task.

(1 mark)

- v) What is the ready-made or shop-bought crossway strip called?

(1 mark)

- vi) Name **ONE** other area where crossway strips can be used on garments (different from where it is used on the jacket in question 1).

(1 mark)

- vii) Apart from being used as a finishing method for edges, crossway strips can be used as a decoration on garments. Describe **ONE** way how this can be done. **DRAW** a diagram to show how a decorative crossway strip can be used on garments.



(1, 1 mark)

h) Style A has round patch pockets.

i) Why are the curved turnings on a round patch pocket clipped?

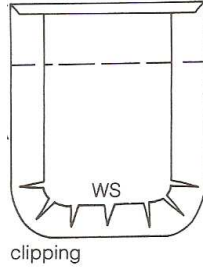

(1½ marks)

ii) A triangle should be machined at the top of each corner of the pocket. Explain why these triangles are sewn here.

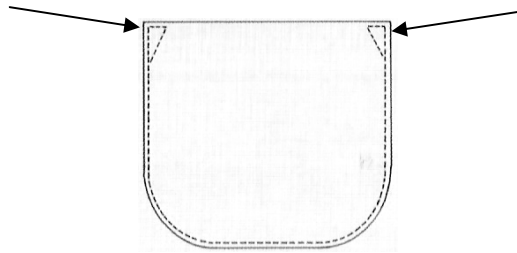

(1½ marks)

iii) Describe how to apply the prepared patch pocket onto the garment using the diagrams below.

	<hr/> <hr/> <hr/> <hr/>
--	-------------------------

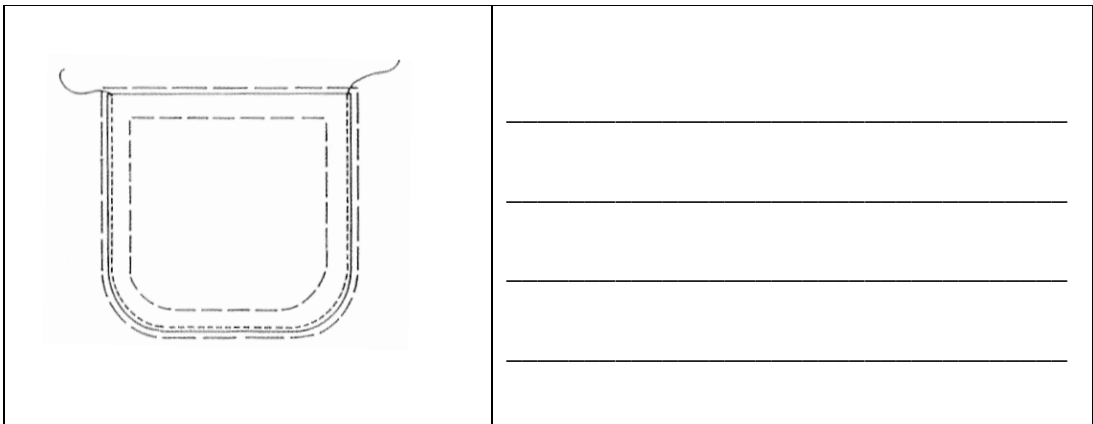

(2 marks)

iv) List **TWO** points that should be kept in mind so that the two pockets on Style A are finished identically on each side.

- _____
- _____

(2 marks)

2. A teenager wants to sew a jacket and apply an appliqué similar to the one on the jacket (Style B) of question 1.

a) The front pattern piece of the jacket is short.

i) Mark and label the alteration line with an arrow on the front pattern piece below.

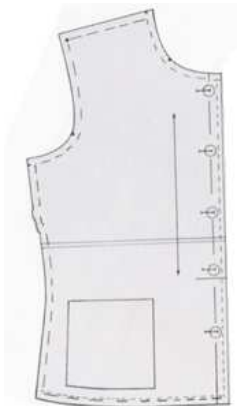

(1 mark)

This question continues on the next page.

ii) Describe how the teenager should lengthen the front pattern piece.

(2 marks)

b) With the help of the diagrams provided below, describe how the teenager should set-in the sleeve.

	<hr/> <hr/> <hr/> <hr/>
	<hr/> <hr/> <hr/> <hr/>
	<hr/> <hr/> <hr/> <hr/>

(6 marks)

ci) At what stage is an appliqué usually sewn on a garment?

_____ (½ mark)

ii) Why is it sewn at this stage?

_____ (1 mark)

iii) In order to make the appliqué on this jacket, the teenager cut out floral motifs from an old curtain which had floral print. Describe how the teenager would make the appliqué by using the following materials.

Floral motifs from an old curtain

Bondaweb

Matching sewing thread

 _____ (3 marks)

3. The flared/boot-leg trousers shown in the diagrams below may be worn with the jacket in question 1.

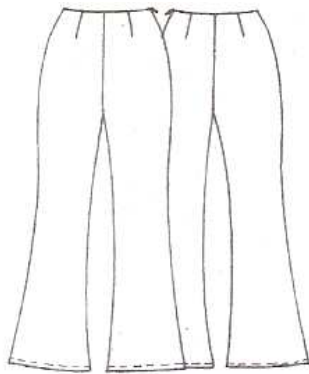

Style A



Style B

a) Give the method of disposing of fullness used on these trousers.

_____ (1 mark)

This question continues on the next page.

b) The trousers **Style A** are fastened with a zip at the side-seam while **Style B** are fastened with a zip at the front using the lapped method.

i) Tick (✓) the **TWO** styles of zip fasteners suitable to be inserted

- at the side seam for **Style A**;

- by the lapped method for **Style B**.

Style A Invisible zip

Style B Invisible zip

Open-ended zip

Open-ended zip

Conventional nylon zip

Conventional nylon zip (2 marks)

ii) Using the diagram below, explain how to shorten a zip fastener, if it is bought too long for its use.

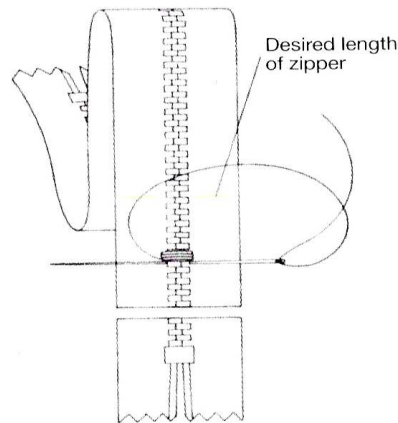

(2 marks)

iii) Name the sewing machine attachment used for attaching a zip fastener to the garment and state why this attachment is used.

Attachment: _____ (1 mark)

It is used because _____

(1½ marks)

iv) Before inserting a zip fastener, seam edges should be _____ .

(1 mark)

v) Identify **TWO** factors that should be considered when buying a zip fastener, apart from the length.

- _____
- _____

(2 marks)

c) The top edge of the trousers **Style A** is finished with a _____ instead of a waistband. (1 mark)

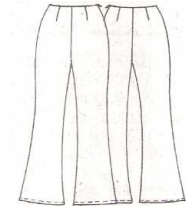

d) Draw the pattern piece of the top edge finishing method, given in the above question.

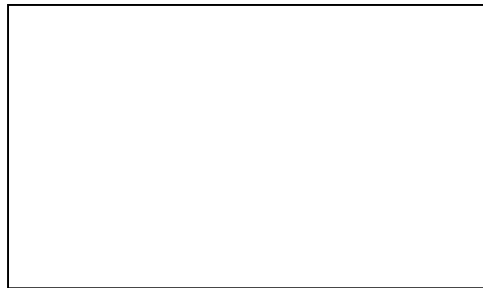

(1 mark)

4. a) There are different types of pleated skirts. Fill in the name of the type of pleats used on the following skirts using these words: **accordion pleat, kick pleat, inverted pleat, box pleat, knife pleat.**

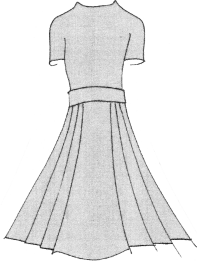
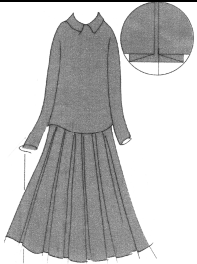
	Pleated skirt	Type of pleat
1		
2		

This question continues on the next page.

DO NOT WRITE ABOVE THIS LINE

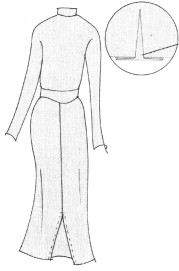
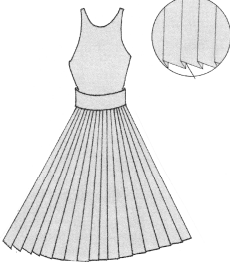
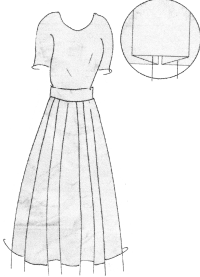
3		
4		
5		

(5 marks)

b) Choose **TWO** of the above pleated skirts and give a brief description of how the pleats can be worked.

	Name	Description
1		<hr/> <hr/> <hr/>
2		<hr/> <hr/> <hr/>

(1, 1 mark)

c) Sketch a diagram of a topstitched pleat.

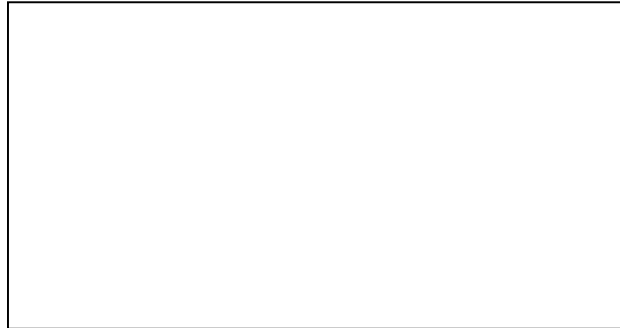

(1 mark)

d) i) Name and draw the **TEMPORARY STITCH** that is used when working pleats on springy or slippery fabrics to hold all layers of the pleats in place.

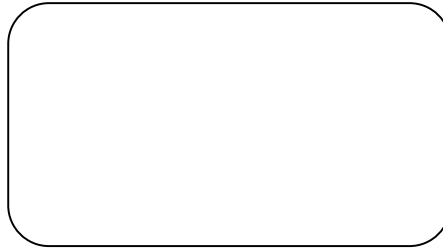

Temporary stitch: _____

(2 marks)

ii) Explain how to work the temporary stitch mentioned in part d(i) when working pleats.

(2 marks)

e) Give **TWO** examples of garments, apart from skirts, which can have pleats.

(1 mark)

This question continues on the next page.

f) Not all types of fabrics can hold pleats **well**. Mark with a tick (✓) the fabrics that are suitable to be pleated.

	Name of Fabric	
1	Silk	
2	Linen	
3	Polyester	
4	Wool	
5	Rayon	

(2 marks)

5. Recently, various school colleges have changed the colour and styles of their students' uniform.

a) Mention **FOUR** garments which form part of a **SUMMER** school uniform.

- _____
- _____
- _____
- _____

(2 marks)

b) i) Draw the pattern pieces of the school shirt worn in **WINTER**, including collar and sleeves. Label each pattern piece.



(4, 2 marks)

ii) Name the type of collar used.

(1 mark)

iii) Why is it advisable to use interfacing when preparing the collar before it is attached to the garment?

(1½ marks)

iv) The interfacing should be tacked or ironed on the wrong side of the undercollar piece.

Why is it done in this way?

(1½ marks)

v) Which fabric would be most suitable for this shirt? Give **ONE** reason for your answer.

Fabric: _____

Reason: _____

(½, 1½ marks)

vi) Which **TWO** measurements are taken in order to calculate the amount of fabric needed for the shirt?

- _____
- _____

(2 marks)

c) It is very important to take good care of the school uniform so it keeps in good condition and lasts longer.

Suggest **THREE** ways how one could keep the school uniform in good condition.

- _____
- _____
- _____

(3 marks)

MATRICULATION AND SECONDARY EDUCATION CERTIFICATE EXAMINATIONS BOARD
UNIVERSITY OF MALTA, MSIDA

SECONDARY EDUCATION CERTIFICATE LEVEL

MAY 2012 SESSION

SUBJECT:	Textiles and Design
PAPER NUMBER:	IIA
DATE:	5 th May 2012
TIME:	9:00 a.m. to 11:00 a.m.

Answer ALL questions.

Section A (40 marks)

1. Natural fibres come from natural sources and are obtained from animals and plants. Wool, silk, cotton and linen are the most natural fibres used.



a) When put under a microscope, all natural fibres look different.

Identify a natural fibre which belongs to each structure.

Fibre Structure	Natural Fibre
These fibres are shaped like a kidney bean or a figure of eight. They twist along their length.	
These fibres are round or oval with scales along the length.	
These fibres can be up to 3000 metres long. They are very smooth and have a rounded, triangular shape.	
These fibres are irregular in shape with both thick and thin sections like bamboo along the length of the fibre. They also have hollow spaces inside.	

(2 marks)

b) Polo shirts made from knitted cotton fabric dyed in different colours are popular among teenagers.

i) Give **TWO** reasons for using knitted cotton yarns to make the polo shirts.

- _____

- _____

(1½, 1½ marks)

ii) In the table below, draw the care label symbols that you would expect to find on a green cotton polo shirt.

Washing symbol	Ironing symbol	Drying symbol	Bleaching symbol
----------------	----------------	---------------	------------------

(4 marks)

iii) Why does the polo shirt need to be thoroughly dried before storing?

(1mark)

c) The pullover below is made from 100% Merino wool.



i) Wool is very absorbent. State **ONE** way how this property is very useful and **ONE** way in which this property may create problems when laundering the pullover.

- Advantage of wool being very absorbent.

- Disadvantage of wool being very absorbent.

(2 marks)

- ii) The symbol below is found on the care label of the pullover. State the meaning of this symbol and explain why it should be applied to woollen garments.

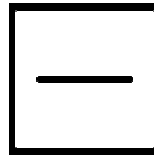

Meaning: _____

Why should this symbol be on the care labels of woollen garments?

(1, 1 mark)

- iii) Why should white wool be kept away from direct sunlight?

(1 mark)

- iv) Mention **ONE** other thing which may harm wool.

(1 mark)

- v) The pullover took up the dyes very well. Why is this so?

(1 mark)

2. A winter top is made from fleece fabric.

- a) Name a manufactured fibre which can be made into fleece fabric.

(1 mark)

- b) The fibres which make fleece fabrics are brushed. Give **ONE** reason why these fibres are brushed.

(1½ marks)

c) Name **TWO** other uses of fleece fabric.

i) _____ ii) _____

(2 marks)

d) Most fleece fabrics are *breathable*. What does *breathable* mean?

(1 mark)

3. Fabric finishes are treatments given to modern fabrics.

a) Give **TWO** reasons why fabric finishes are used during the manufacturing of fabrics.

i) _____
ii) _____

(3 marks)

b) Brushed cotton might be dangerous to wear if untreated. Why?

(1 mark)

c) *Beetling* is a mechanical finish.

i) Name the fabric to which *beetling* is applied.

(1 mark)

ii) Why is *beetling* applied to this type of fabric?

(1 mark)

d) Write down the trade name of the fabric finish applied to a fabric to make it:

i) Flame-retardant: _____

ii) Stain resistant: _____

(2 marks)

e) What property is given to a fabric by the following finishes?

i) Tebilizing: _____

ii) Fixaform: _____

iii) Sanforized: _____

(3 marks)

- f) Finishes are also applied to yarns to give them a particular property before they are woven or knitted into fabric. *Mercerizing* is one example. Define the term *mercerizing*.

(1½ marks)



- g) Modern technology is applying different finishes to fabrics to embellish them. The production of metal yarns which are woven into fabrics is a typical example. Traditional metallic fabrics include Lurex, often used for elegant evening wear.

Name **ONE** other fabric that has this type of finish.

_____ (1 mark)

4. Choosing the right style for your figure is very important to achieve a good look.

- a) The figure type needs to be considered when choosing striped fabrics.

DRAW a striped pattern on the picture of the dress, keeping in mind that the person wants to look taller.

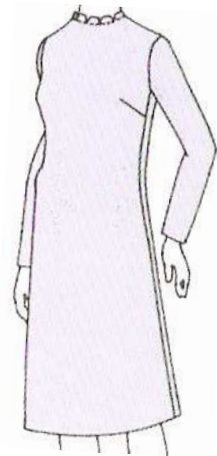

(2 marks)

- b) The picture below shows a knitted dress suitable for a pregnant woman. It is made of 95% Viscose and 5% Elastane.



Identify **TWO** factors which make this dress suitable for a pregnant woman.

- i) _____

- ii) _____

(2 marks)

Section B: Answer All questions.

5. a) Your friend is going to buy a new sewing machine.

- i) State **THREE** points she needs to consider when buying the sewing machine.

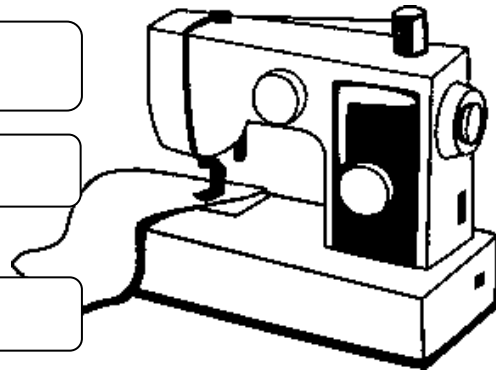

(3 marks)

- ii) List **TWO** important safety rules to be observed when your friend uses a sewing machine. Write the safety rules on the poster below which she can attach in the Textiles Studies room.

(2 marks)

**Safety Rules
when using 
the Sewing Machine!**

1 _____



2 _____

b) The sewing machine is one of the essential pieces of equipment needed for creating or altering garments.

i) Name each part indicated in the picture below. Write the name of the part in the table below.

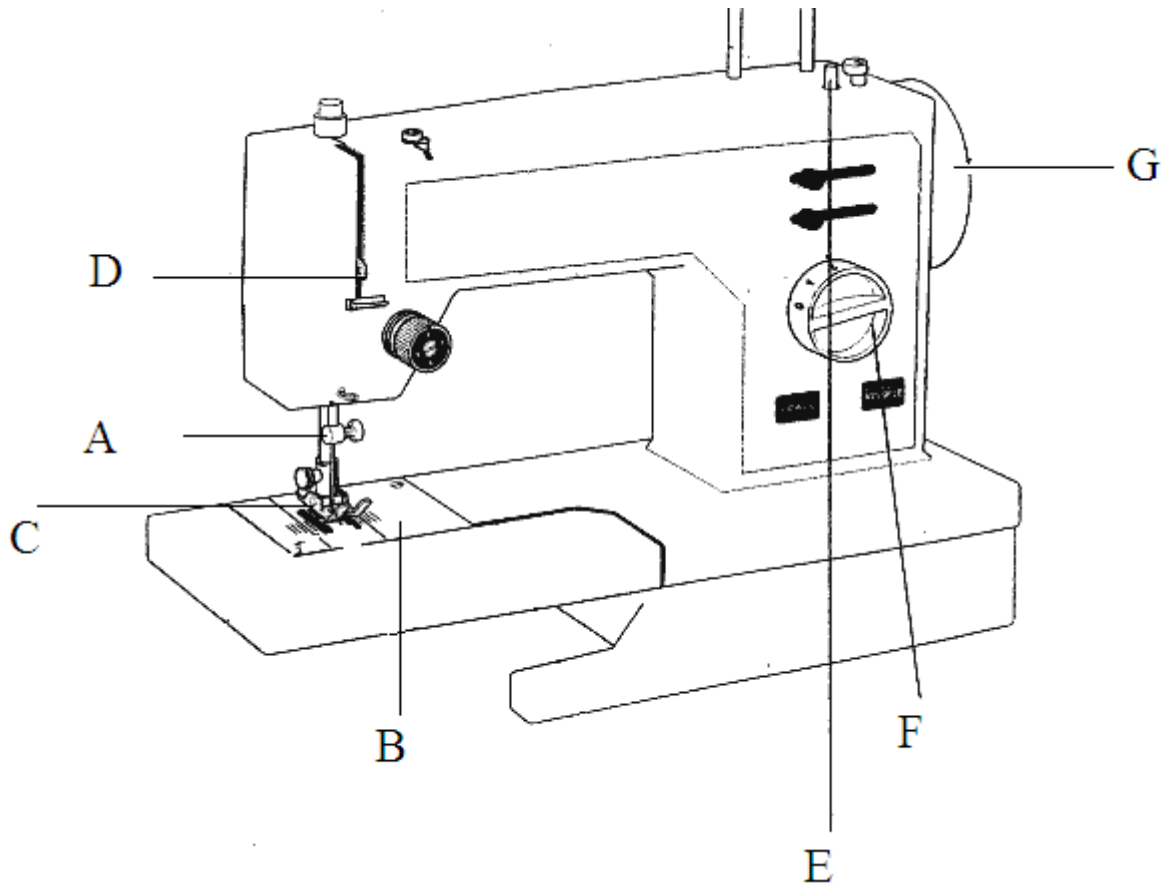

A	
B	
C	
D	
E	
F	
G	

(7 marks)

- ii) Some problems could occur while using the sewing machine. Suggest solutions for the following problems encountered.

Thread breaking	Needle breaking	Missing stitches	Seams puckering
↓	How would you solve this problem?		↓
↓	↓	↓	↓

(4 marks)

- c) The following is a description of how to thread the sewing machine. Fill in using suitable words.

The top thread comes from the _____ via one or two _____
_____ and then goes between the tension discs. From there it goes through the
take up _____, and then via thread guides to the _____ itself. The
position of the last thread guide indicates which way the needle is threaded. Always
test the machine on a scrap of the fabric to be used. The lower thread is wound to the
_____. Put the bobbin in the bobbin _____ and make sure to leave the end
of the thread hanging out. To get the bottom thread to go through the hole beneath the
needle, hold the top thread and turn the _____ towards yourself once.
As the needle goes down, it interlocks the bottom thread.

(4 marks)

6. A school leaver has found a summer job in an office where she will be dealing with the public and is expected to dress appropriately.
- (a) Using this template to help you, sketch a suitable outfit. Label the outfit to show the different style features.

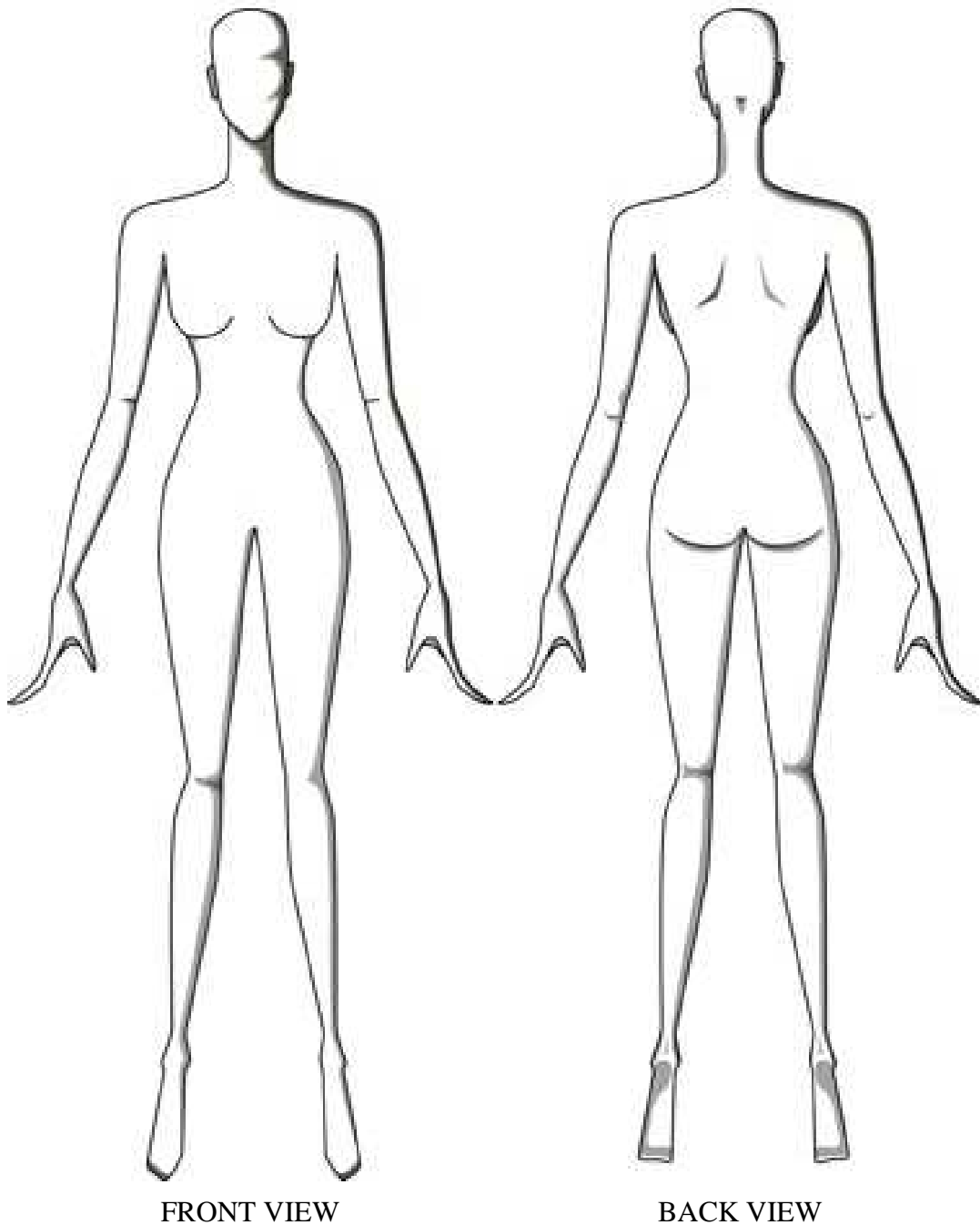

(6, 4 marks)

(b) Choose **ONE** item of clothing from the sketch you have drawn on the template in (a) and suggest **TWO** suitable fabrics.

i) Item of clothing: _____

ii) Fabrics chosen:

- _____
- _____

(2 marks)

(c) Describe how the outfit designed in (a) takes into account the following:

(i) Comfort

(ii) Aesthetic appeal (appearance)

(iii) Current fashion trends

(2, 2, 2 marks)

(d) Identify **FOUR** factors that would influence a teenager when buying clothes.

I.

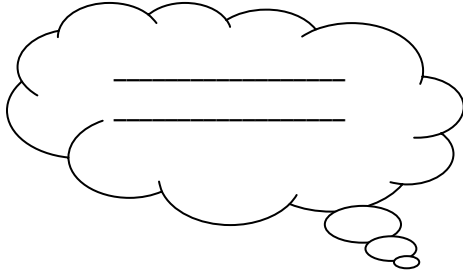

II.

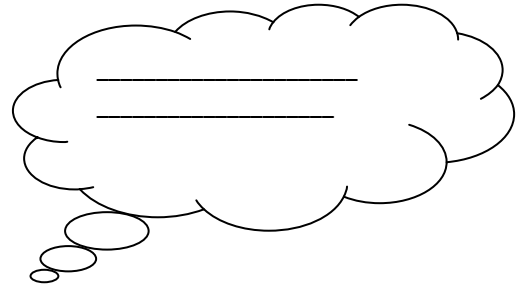

III.

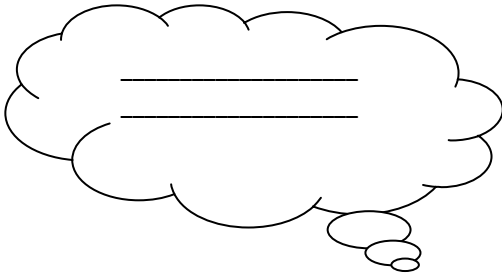

IV.

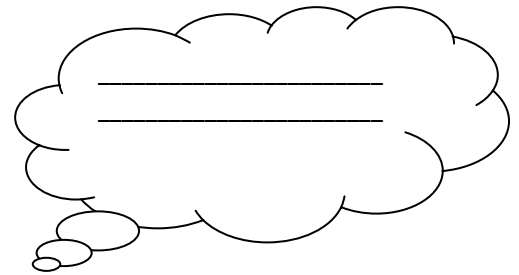

(2 marks)

7. Your Textiles Studies teacher has encouraged you to start your own small, part-time business of decorative accessories when you leave school.

(a) i) Design a small clutch bag, showing your sewing and embroidery skills. (3 marks)

ii) Label the decorations used, including the embroidery stitches.

(5 marks)

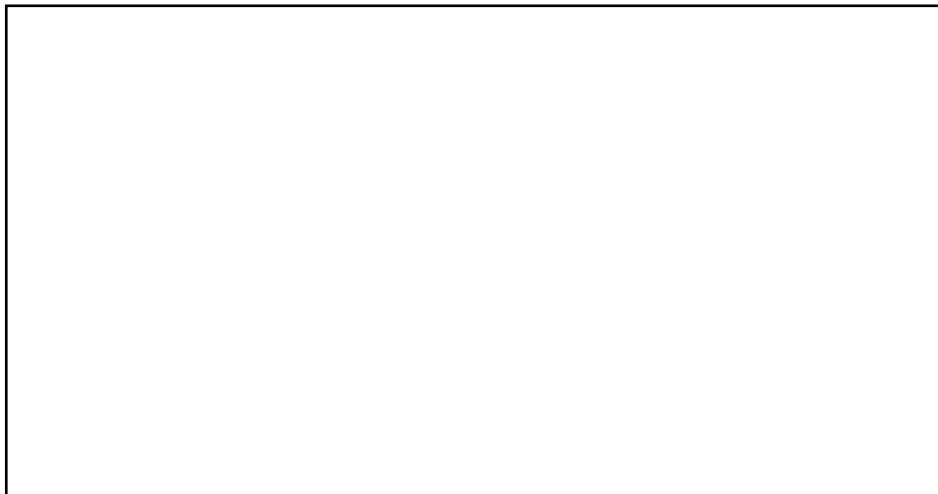

iii) Using diagrams, describe how to work **ONE** of the embroidery stitches mentioned in (a i).

(2 marks)

iv) Name **TWO** small pieces of equipment used to make embroidery stitches.

- _____
- _____

(1 mark)

(b) i) Which **TWO** colours will be used for the clutch bag sketched in part a(i)?



(1 mark)

ii) How could you test the fabric you will be using for the clutch bag for colour fastness?

The pictures below might help you out.



(2 marks)

iii) Name **TWO** other methods of adding colour to fabrics.

(2 marks)

- iv) One of the methods used to colour fabrics is tie-and-dye. Complete the following flow chart with the steps of how to make Tie-and-Dye.

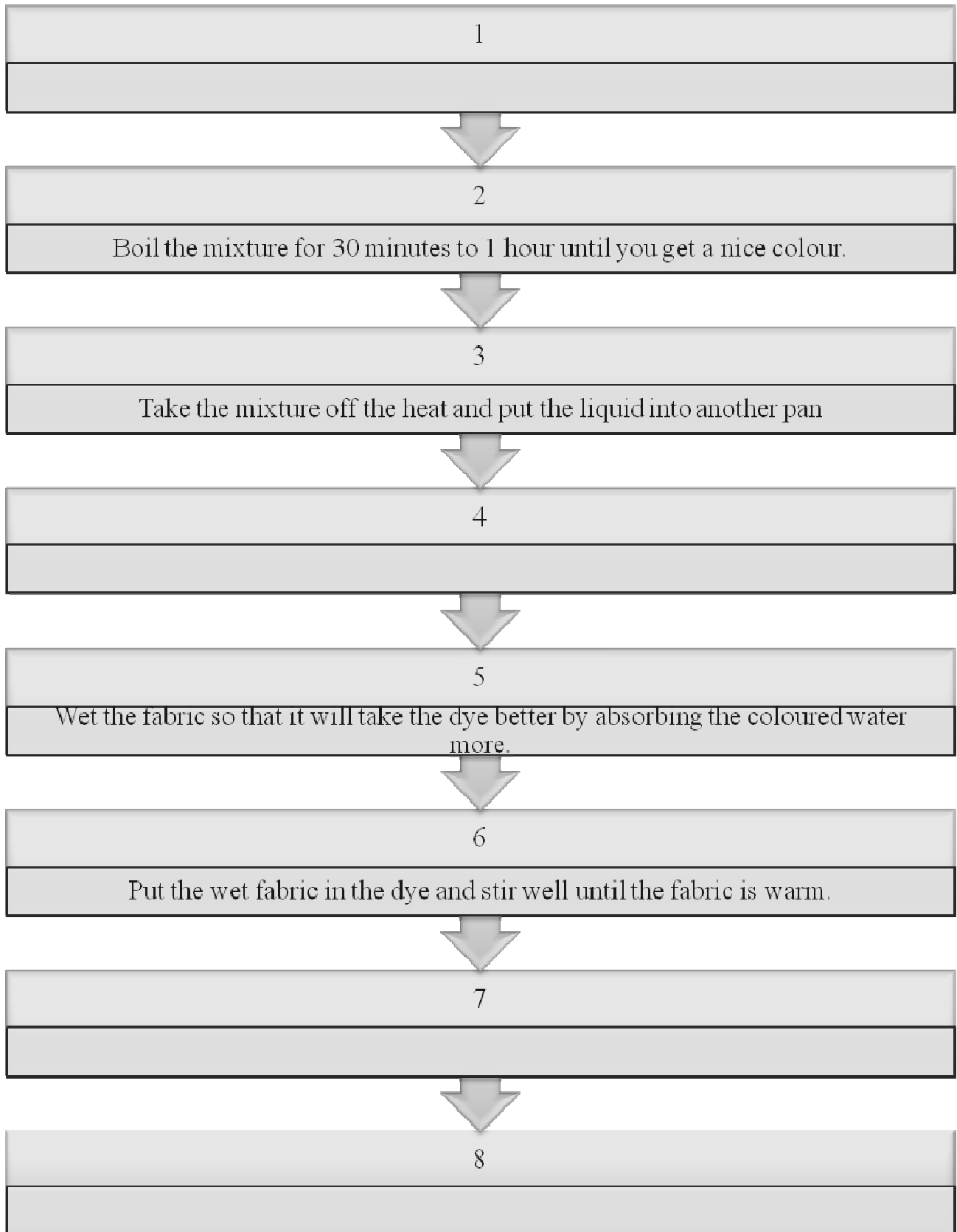

(4 marks)

MATRICULATION AND SECONDARY EDUCATION CERTIFICATE EXAMINATIONS BOARD
UNIVERSITY OF MALTA, MSIDA

SECONDARY EDUCATION CERTIFICATE LEVEL

MAY 2012 SESSION

SUBJECT: **Textiles and Design**
 PAPER NUMBER: **IIB**
 DATE: **5th May 2012**
 TIME: **9:00 a.m. to 11:00 a.m.**

1. Wool, silk, cotton and linen are natural fibres which come from natural sources.

- a) When seen under a microscope, all the natural fibres look different.
 Using the diagrams and information given below, **NAME** the natural fibres.

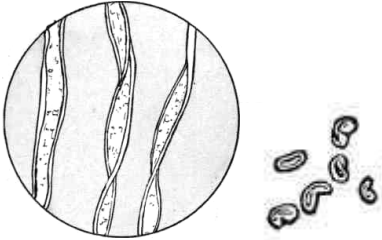
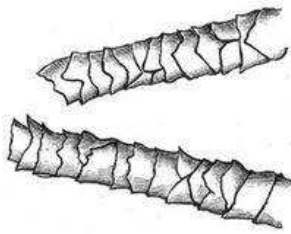

Fibre Structure	Natural Fibre
 <p>These fibres are shaped like a kidney bean or a figure of eight. They twist along their length.</p>	
 <p>These fibres are round or oval with scales along the length.</p>	

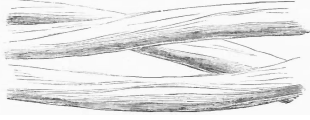
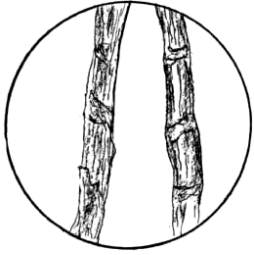
 <p>These fibres can be up to 3000 metres long. They are very smooth and have a rounded, triangular shape.</p>	
 <p>These fibres are irregular in shape with both thick and thin sections like bamboo along the length of the fibre. They also have hollow spaces inside.</p>	

(4 marks)

- b) Polo shirts are usually made from knitted cotton fabric.





- c) i. Why is cotton a suitable fabric to use for polo shirts?

(1½ marks)

- ii. Why is a knitted fabric construction method used to make the polo shirts?

(1½ marks)

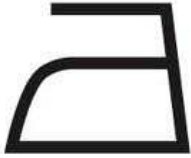
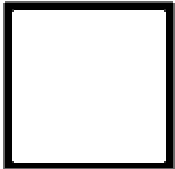
iii. Fill in the following care label symbols found on a green cotton polo shirt.

			
Washing symbol	Ironing symbol	Drying symbol	Bleaching symbol

(4 marks)

d) The pullover below is made from 100% Merino wool.



i. Which wool symbol shows that the pullover is made from 100% pure new wool?



Symbol A



Symbol B

Answer: Symbol _____

(1 mark)

ii. Why does wool take a long time to dry?

(1 mark)

- iii. The dry flat symbol is found on the care label of the woollen jersey.

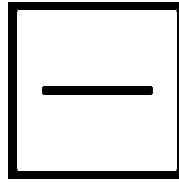

Why should woollen garments be dried flat?

(1 mark)

- iv. What would happen if white wool is kept for a long time in direct sunlight?

(1 mark)

- v. This is a small insect which feeds on wool and harms it. What is this insect called?

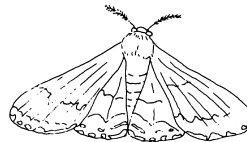

(1 mark)

2. A winter top is made from fleece fabric.

- a) Name a synthetic fibre which fleece is made from.



(1 mark)

- b) The synthetic fibres which fleece is made from are brushed. Name **ONE** property which is obtained from brushing these fibres.

(1 mark)

- c) Name **ONE** advantage of fleece fabric (different from the one mentioned in question 2b).

(1 mark)

- d) Name **TWO** other items which can be made from fleece fabric.

- i) _____ ii) _____

(1 mark)

3. Fabric finishes are treatments which manufacturers use on fabrics.

a) Give **ONE** reason why manufacturers use fabric finishes on certain fabrics.

_____ (1½ marks)

b) Match each fabric finish with its trade name.

	Fabric Finishes		Trade Names
1.	Flame-retardant finish		Permanently Pleated
2.	Moth proofing		Sanforized
3.	Crease resistance		Proban Treatment
4.	Fixaform		Scotchgard
5.	Shrink resistance		Tebilizing
6.	Stain resistance		Mitin

(6 marks)

c) Using the words in the box, complete the sentences below about fabric finishes.

smoother	linen	natural	lustre
----------	-------	---------	--------

i *Beetling* is a mechanical finish applied to _____ to improve _____.

ii. *Mercerizing* is a finish applied to _____ fibres to make them _____.

(4 marks)

d) Brushed cotton might be dangerous to wear if left untreated. Why?

_____ (1½ marks)

4. Choosing the right style for your figure is very important in order to have a good look.

- a) The figure type needs to be considered when choosing striped fabrics. Draw a striped pattern on the picture of the dress, keeping in mind that a short person wants to look taller.

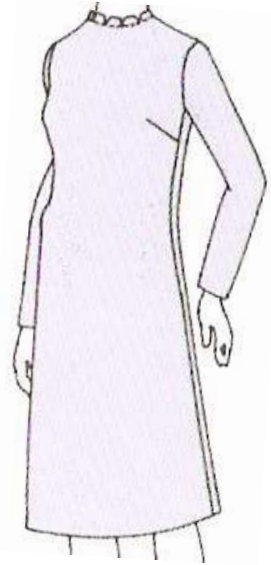

(2 marks)

This is a knitted dress suitable for a pregnant woman.

Give **ONE** factor which makes the style of this dress suitable for a pregnant woman.



(1 mark)

- b) Apart from choosing the correct style, it is also important to choose a colour which best suits the person.

Fill in the blanks with the words provided below.

pale

features

pastel

strong

Some colours suit a person better than others. This depends on the colour of the person's _____, such as skin, hair and eyes. Black hair contrasts well with _____ colours. Blonde people often look best in _____ shades. People with _____ skins look rather 'washed out' in dark colours.

(4 marks)

Section B

5. a) Your friend is going to buy a new sewing machine.

- i. Write **THREE** points which she needs to keep in mind when buying the sewing machine. (*One has been worked for you*)

1. *How often are you going to use it?*

2.

3.

4.

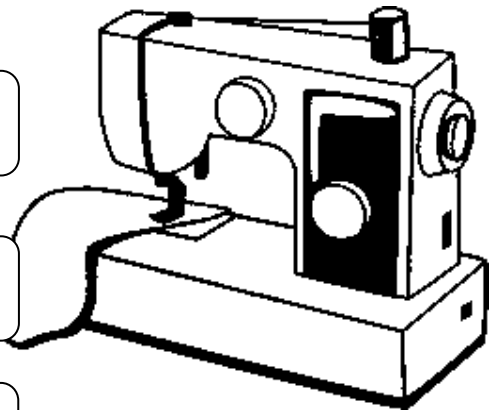

(3 marks)

- ii. List **TWO important** safety rules to be followed when your friend is using the sewing machine. Write the safety rules in the poster below so that she can attach it in the Textile Studies room.

(2 marks)

Safety Rules when using the Sewing Machine!



Learn to start and run the machine slowly
and evenly.



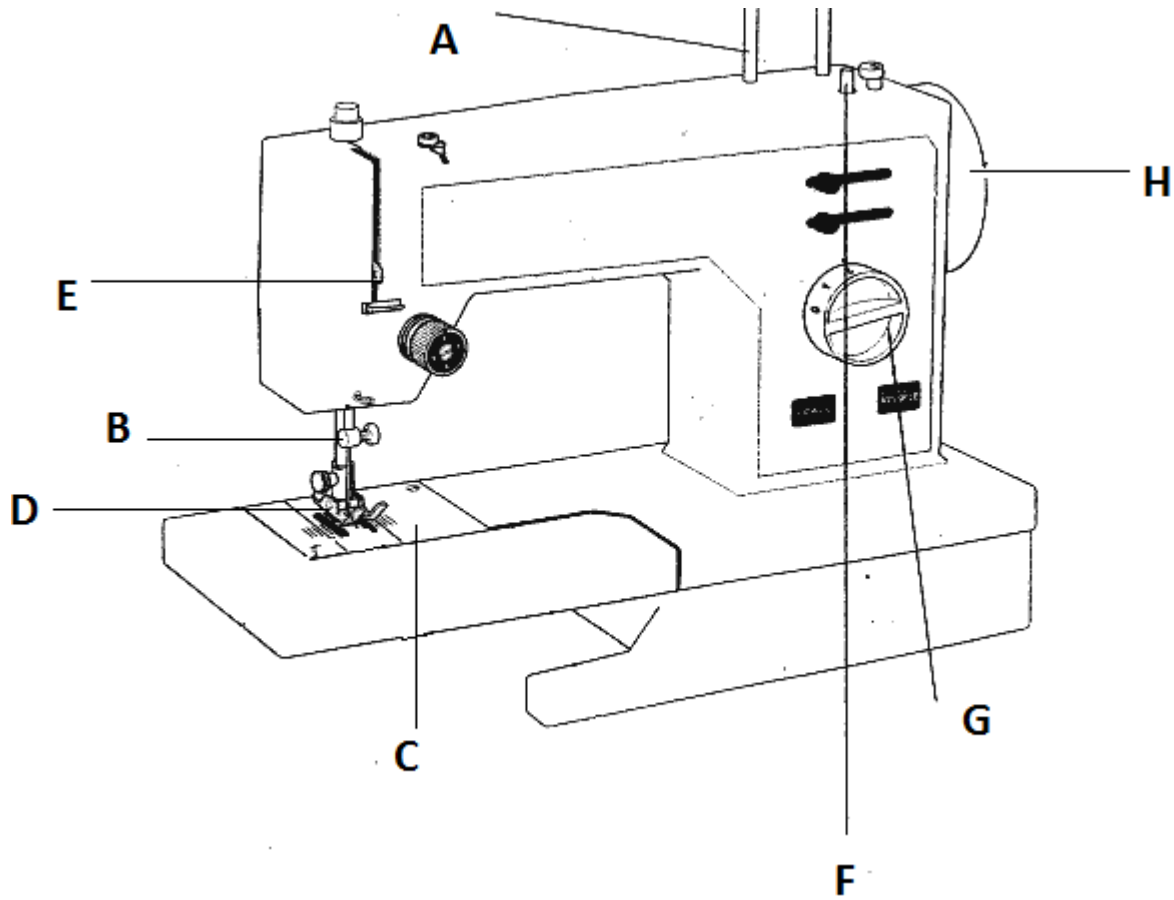

- b) i. The sewing machine is made up of different parts. Write the letter of the part in the table below. (The first one has been done for you.)

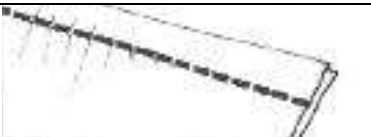

	Balance wheel/Hand wheel
	Thread guide
	Feed dogs
	Bobbin winder
A	Spool pin/Reel holder
	Needle clamp
	Stitch length regulator/Stitch width regulator
	Feed dog/Throat plate

(7 marks)

- ii. Some problems could occur while sewing. Match the problem with the reason and the solution. (*The first one has been done for you.*)

	Problem		Cause		Remedy
1	 <p>Thread breaking</p>		Bobbin upside-down or upper thread too loose		Loosen tension/ change needle or thread
2	 <p>Damage to fabric</p>		Needle blunt, twisted or too low		Correct bobbin or tighten top tension
3	 <p>Missing stitches</p>		Blunt needle	1	Loosen top tension
4	 <p>Seams puckering</p>	1	Top tension too tight		Change the needle
5	 <p>Loops on wrong side of stitching</p>		Tension too tight/ Needle too large or thread too thick		Replace needle of the correct size

(4 marks)

- c) The following is a description of how to thread the sewing machine. Fill in using suitable words from the list below.

bobbin**balance wheel****reel****lever****thread guides****case****needle****fabric**

The top thread comes from the _____ via one or two _____ and then goes between the tension discs. From there it goes through the take up _____, and then via thread guides to the _____ itself. The position of the last thread guide indicates which way the needle is threaded. Always test machine on a scrap of the _____ to be used. The lower thread is wound to the _____. Put the bobbin in the bobbin _____ and make sure to leave the end of the thread hanging out. To get the bottom thread to go through the hole beneath the needle, hold the top thread and turn the _____ towards yourself once. As the needle goes down, it interlocks the bottom thread.

(4 marks)

6. A school leaver has found a summer job in an office where she will be dealing with clients. She is expected to dress appropriately.
- a) Using the template (on the next page) to help you, draw a suitable outfit for summer. Label the outfit to show the different style features.

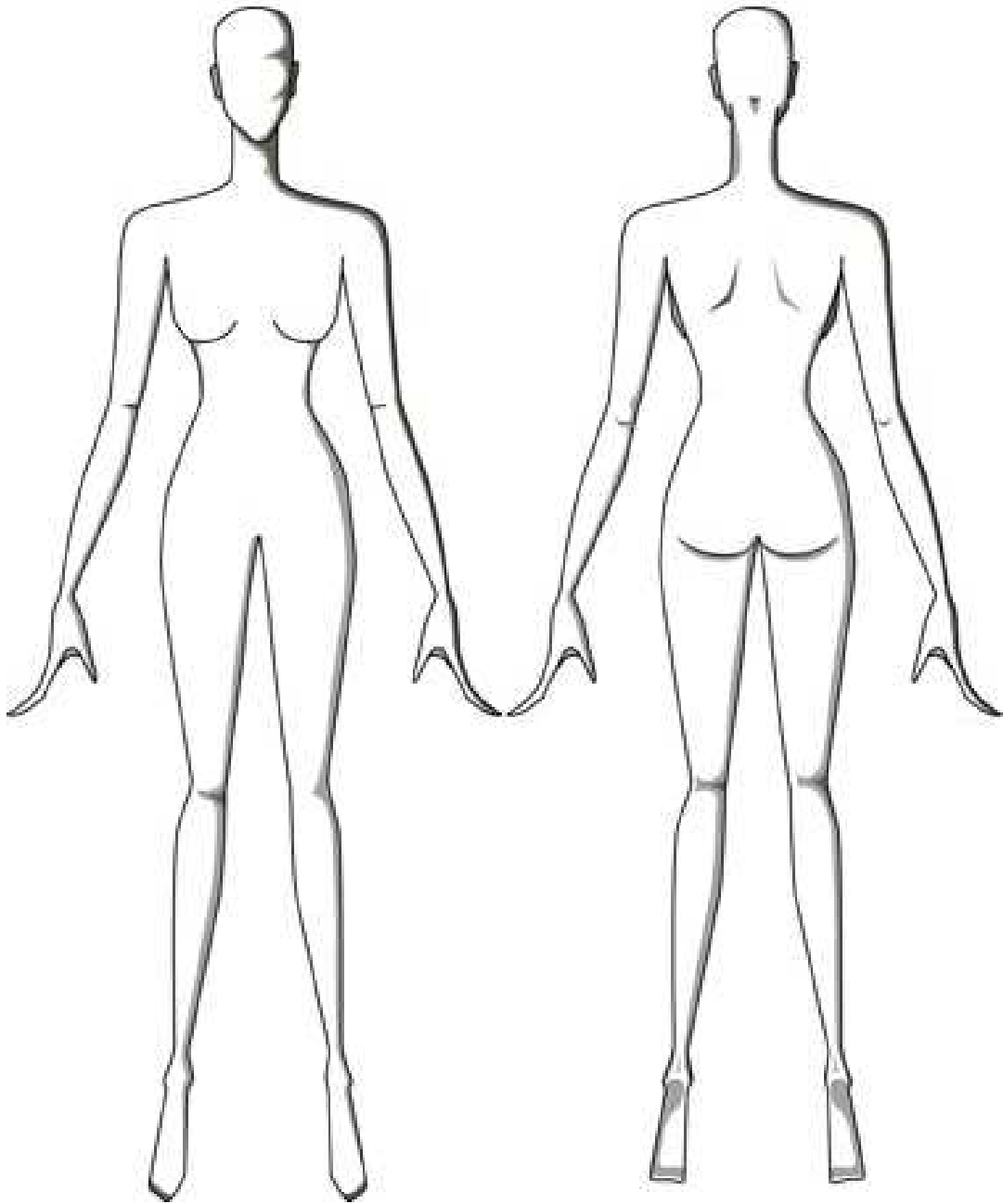

FRONT VIEW

BACK VIEW

(6, 4 marks)

- b) Choose **ONE** item of clothing for the sketch you have drawn above and suggest **ONE** suitable fabric.
- Item of clothing: _____
 - Fabrics chosen: _____

(1 mark)

Please turn the page.

c) Explain how the outfit designed in (a) could be:

i. Comfortable

<hr/> <hr/> <hr/>

ii. Attractive

<hr/> <hr/> <hr/>

iii. Fashionable

<hr/> <hr/> <hr/>

(2, 2, 2 marks)

d) Which factors would influence a teenager when buying clothes? Give **THREE** factors.



7. Your Textiles Studies teacher has encouraged you to start your own small, part-time business of decorative accessories when you leave school.

a) i. Design a small clutch bag, showing your sewing and embroidery skills. (5 marks)

ii. Label the decorations used. (3 marks)

Please turn the page

b) Look at the following pictures.

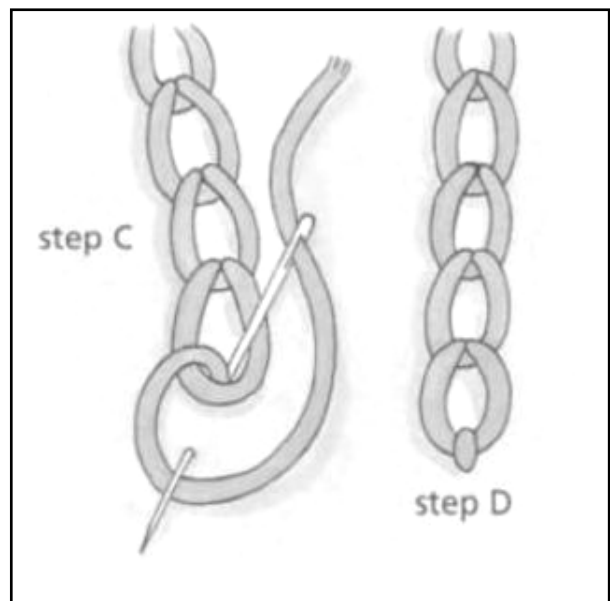
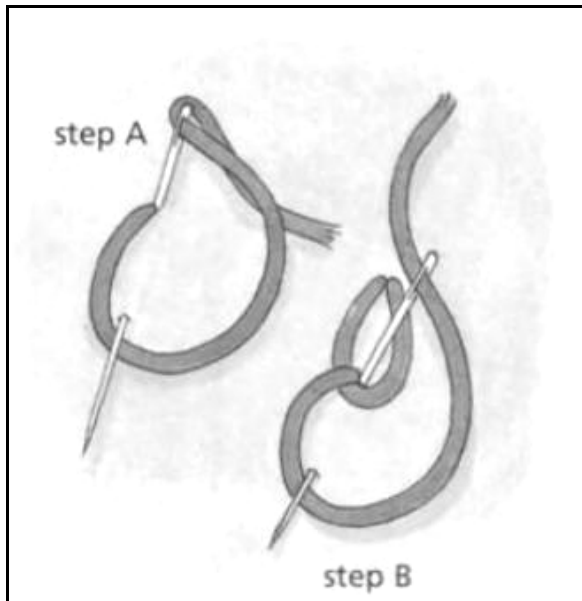

- i. Name this embroidery stitch: _____ (1 mark)
- ii. Using the above pictures and the words given below, complete this paragraph with the description on how to work this embroidery stitch.
wrap needle step D forward side out last fabric

Work from top to bottom. As shown in step A, bring the _____ through the fabric and insert it into the same hole. Bring the needle _____ on the same _____ of the fabric a little farther _____. Moving to step B, _____ the thread round the needle. Pull the needle through the _____. As seen in step C, you can repeat many times. To fasten off, secure the _____ loop of the chain with a tiny stitch, as shown in _____.

(4 marks)

- iii. Name **THREE** small equipment used to make the embroidery stitches.

(3 marks)

- iv. Suggest **TWO** colours that would be suitable for the bag and shoes, if it is to be worn with a light brown dress.

_____ (1 mark)

- c. The following sentences describe the method how to carry out a test for colour fastness. Put these steps in the correct order. The first one is done for you.

Put samples in bowls and wait for 15 minutes.	
Leave to dry or iron.	
Observe colour of water.	
Fill two bowls with soapy water, one at 40°C and one at 95°C.	1
Compare with unwashed samples.	
Record your results.	
Rinse your samples.	

(3 marks)